

NOTES:

1. APPLICABLE SPECIFICATIONS AND STANDARDS:

- A. ANSI Y14.5-1982.
- B. MIL-G-10944.
- C. ANSI B46.1.
- D. MIL-STD-120 REF.

2. MATERIAL: HIGH-SPEED TOOL STEEL, T1 TO T15 OR M1 TO M62 PER ASTM A 600 OR ALLOY TOOL STEEL, A2 PER ASTM A 681.

3. SUGGESTED HEAT TREATMENT: QUENCH, TEMPER, AND STABILIZE.

4. HARDNESS: ROCKWELL C 60 TO 64 OR EQUIVALENT.

5. SURFACE FINISH: $\sqrt{32}$ EXCEPT AS NOTED.

6. BREAK ALL CORNERS .03 EXCEPT AS NOTED.

7. NEWLY-PRODUCED GAGES SHALL MEET ALL REQUIREMENTS OF THE DRAWING. ANNUAL FIELD RE-CALIBRATION REQUIREMENTS ARE NOTED; ACTUAL MEASUREMENT OF BASIC DIMENSION AND OVERALL LENGTH MAY BE USED TO OBTAIN DATUM LOCATION. WITH REGARD TO ANNUAL FIELD RE-CALIBRATION, A REVISION LETTER AND MANUFACTURER'S CAGE CODE MAY BE MARKED ON THE GAGE PER EARLIER DRAWING REVISIONS.

8. ALL MAJOR QAP CHARACTERISTICS SHALL BE LISTED ON THE GAGE RECORD CARD IN THE BLOCK ENTITLED "REQUIRED COMPONENT DIMENSION." EACH DIMENSION SHALL BE MEASURED AND THE MEASUREMENT RECORDED IN THE BLOCK ENTITLED "ACTUAL GAGE DIMENSIONS." EACH CARD SHALL BE SIGNED AND DATED BY THE CONTRACTOR CERTIFYING THAT THE GAGE COMPLIES WITH THE REQUIRED DIMENSIONS SPECIFIED ON THE GAGE DRAWING AND SHALL BE PLACED IN THE PACKAGING WITH THE GAGE. EACH PACKAGE ASSEMBLY SHALL CONTAIN ONE GAGE AND THE GAGE RECORD CARD SPECIFIC TO THAT GAGE. THE GAGE RECORD CARD MUST BE COMPLETED AT THE TIME OF ACCEPTANCE BY THE ACCEPTANCE POINT (ORIGIN OR DESTINATION) IDENTIFIED IN THE CONTRACT.

9. THE LABEL OR OTHER MARKING SHALL CONTAIN A LINEAR BAR CODE (MACHINE-READABLE INFORMATION), ALONG WITH THE HUMAN-READABLE INTERPRETATION, REPRESENTING THE GAGE IDENTIFICATION NUMBER. A DUPLICATE LABEL OR OTHER MARKING SHALL APPEAR ON THE GAGE RECORD CARD IN THE BLOCK ENTITLED "IDENTIFICATION NO." EACH GAGE IDENTIFICATION NUMBER SHALL BE CHOSEN/ASSIGNED BY THE GOVERNMENT.

10. QUALITY ASSURANCE PROVISION REQUIREMENTS PER DRAWING NUMBER 12993884 APPLY.

CERTIFICATION OF THE 1.4706-.0002 DIMENSION IS ACHIEVED BY PRECISION MEASUREMENT OF DIMENSIONS M1, M2, AND 1.5625 WITHIN THE TOLERANCES SPECIFIED. THE VALUES FOR M1 AND M2 ARE DETERMINED BY USING THE FORMULAS BELOW, WHERE THE VARIABLE L IS THE ACTUAL MEASURED VALUE OF THE 1.5625±.0050 LENGTH.

$$M1 = .40263 - .8489(L - 1.5625)$$

$$M2 = .56584 - .8489(L - 1.5625)$$

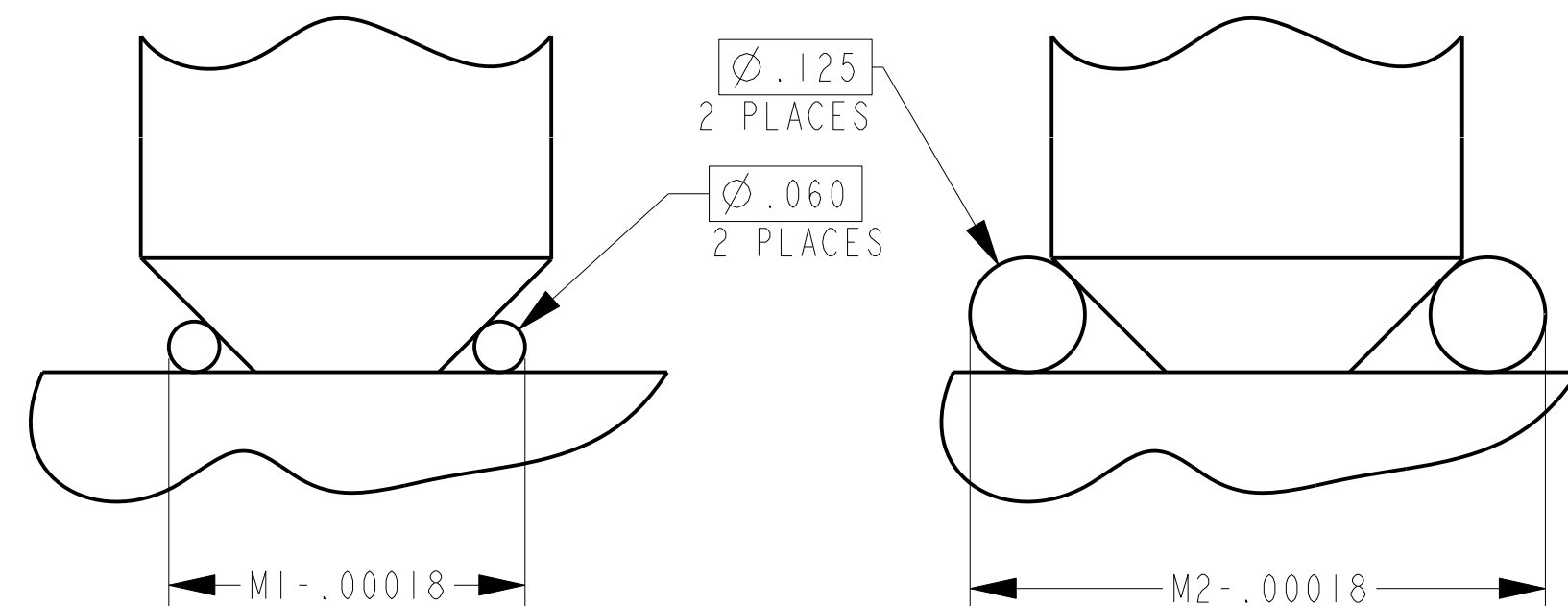

MARK DATA IN BLOCK BELOW ON GAGE IN POSITION SHOWN

8443949
RIFLE/CARBINE, 5.56 MM
HEADSPACE (MAX) 1.4706

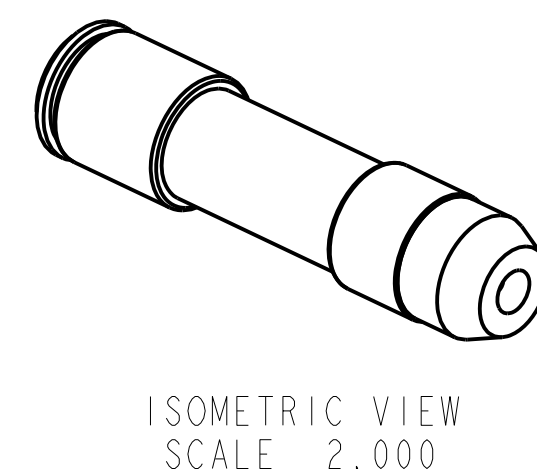
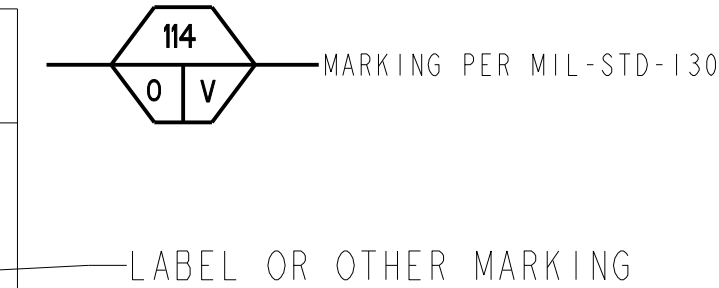

11. OPTIONAL PROTECTIVE FINISH ON NON-BEARING SURFACES ONLY: FINISH 3.3.2 OF MIL-STD-171. MAY BE APPLIED PRIOR TO FINAL MACHINING OF BEARING SURFACES.



REVISIONS				
MODEL REV	DRAWING REV	DESCRIPTION	DATE(YEAR-MO-DA)	APPROVED
-	F	REDRAWN WITH CHANGE NOR L07S3069 / 2007-11-06	2007-11-27	BMG
A	G	NOR L08S3113 / 2008-09-25	2008-10-17	BMG
B	H	NOR L09S3001 / 2009-01-21	2009-02-04	BMG
C	J	NOR L09S3130 / 2009-09-08	2009-09-10	BMG

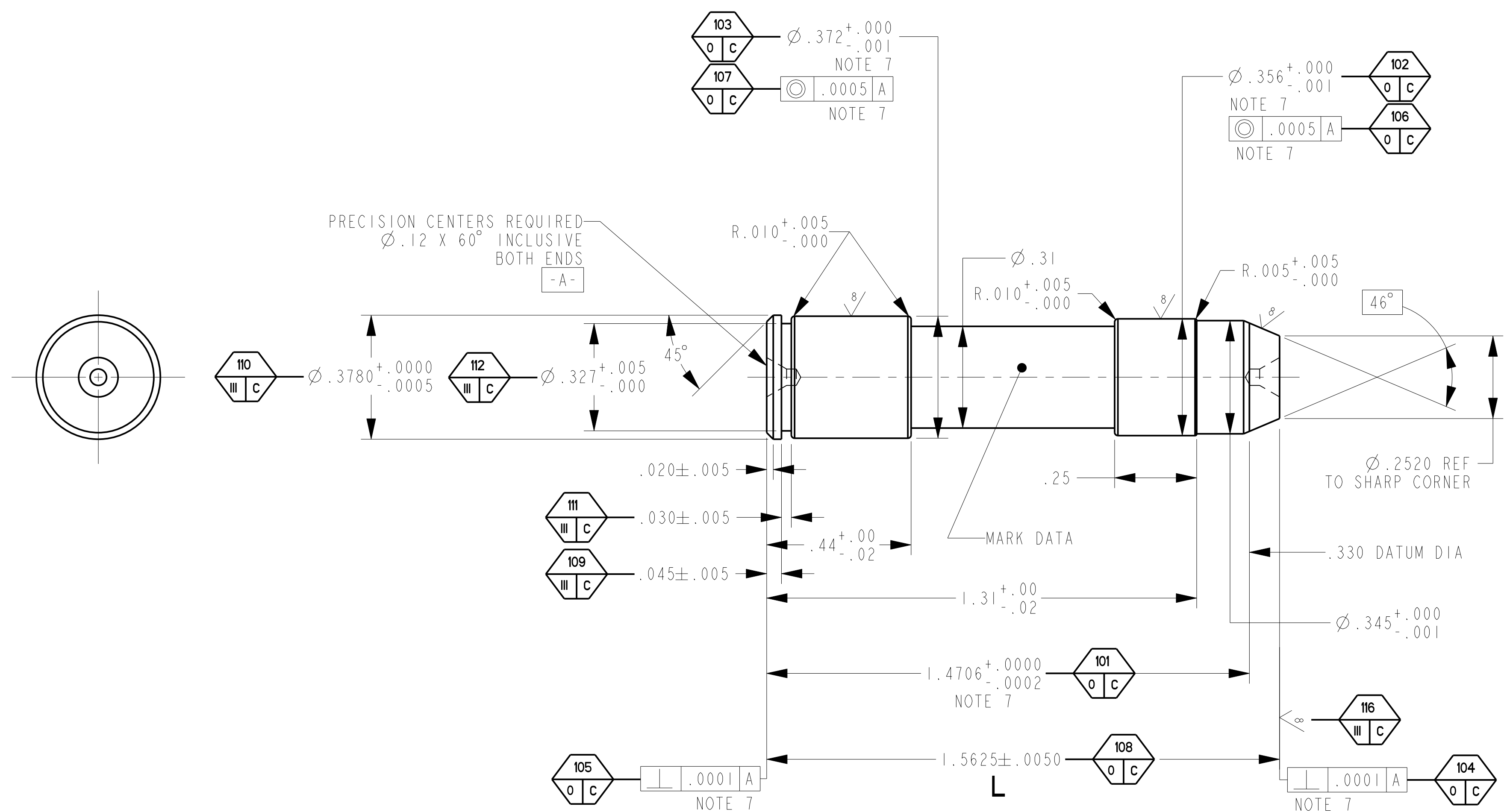

CURRENT DESIGN ACTIVITY CAGE CODE 19200
US ARMY
ARMAMENT RESEARCH, DEVELOPMENT AND ENGINEERING CENTER
PICATINNY ARSENAL, NEW JERSEY 07806-5000

THIS DRAWING WAS GENERATED FROM A SOLID MODEL AND IS CAD MAINTAINED. CHANGES SHALL BE INCORPORATED BY THE DESIGN ACTIVITY.

PART NO. 8443949

DISTRIBUTION STATEMENT A. APPROVED FOR PUBLIC RELEASE; DISTRIBUTION IS UNLIMITED.

PMIC	M4A1	DO NOT SCALE DRAWING UNLESS OTHERWISE SPECIFIED DIMENSIONS ARE IN INCHES	CONTRACT NUMBER		DESIGN ACTIVITY US ARMY ROCK ISLAND ARSENAL ROCK ISLAND, ILLINOIS
	M4		CONTRACTOR		
MECHANICAL PROPERTIES	M16A4	TOLERANCES ON ANGLES ± 2° 2 PLACE DECIMALS ± .01 3 PLACE DECIMALS ± .005	DRAWN BY R. BROWN	DATE(YEAR-MO-DA) 1970-03-02	GAGE, HEADSPACE (MAX)
	M16A3		CHECKER D. COLLUM	ENGINEER A. FOLTZ	
YP	M16A2	THIRD ANGLE PROJECTION	ENGINEER W. STEVENS	QUALITY ENGINEER A. ANDRADE	SIZE D
TS	M16A1		DRAWING APPROVAL R. BROWN	DATE 2007-11-06	CAGE CODE 19204
EL2	M16	MATERIAL ENGR MODELED BY R. BROWN	DESIGN APPROVAL J. WINDHAM	DATE 2007-11-06	DWG NO. 8443949
RA			APPLICATION	SCALE 4.000	UNIT WT. 0.040
BH					SHEET 1 OF 1
RH					