

INSTRUCTIONS

FOR THE OPERATION OF THE

COLT ARMALITE AR-15 Automatic Rifle

CALIBER .223

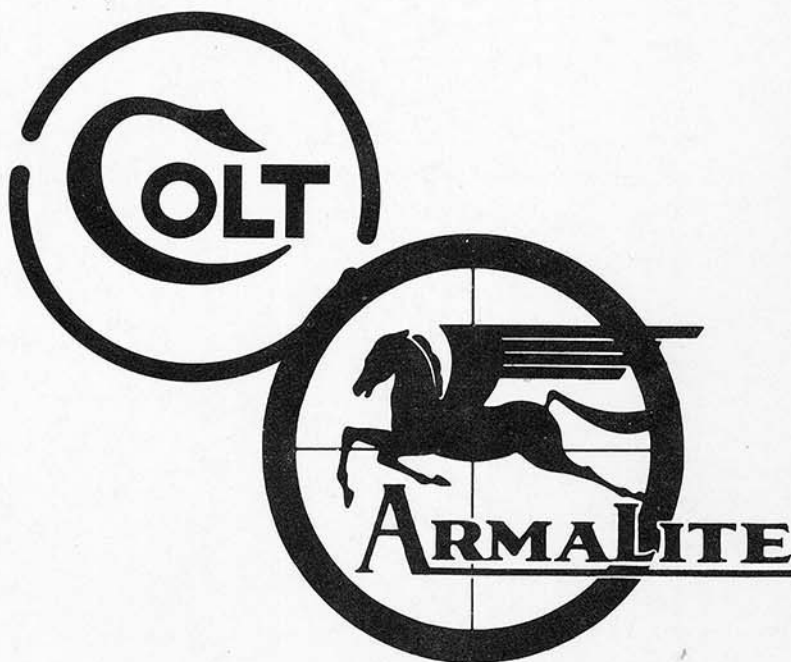

COLT'S PATENT FIRE ARMS MFG. CO., INC.
HARTFORD 15, CONN., U. S. A.

Digitized by:

FOREWORD

This manual is published for the information and guidance of ordnance personnel whose duties involve the use, maintenance and repair of the caliber .223 Basic Infantry Weapon, AR-15. Disassembly, assembly, cleaning and minor repairs may be undertaken by anybody.

In all cases where the nature of the repair or adjustment is beyond the scope or facilities of the unit, the responsible ordnance division should be informed in order that trained personnel with suitable tools and equipment may be provided.

INTRODUCTION

The Colt Armalite AR-15 is the most modern light weight combat rifle combining the accuracy of a sniper rifle with the firepower of a machine gun. Designed by the Armalite Division of Fairchild Engine & Aircraft Corporation and manufactured by Colt's Patent Fire Arms Manufacturing Company, the Colt AR-15 is being heralded as the most important advancement in small arms in the past 80 years. The engineering division of Fairchild with its metallurgical experience in jet engine development, the guided missile division with its advanced plastic techniques, and outstanding leadership in the aircraft field, have been combined with the talents of Colt's Patent Fire Arms Manufacturing Company to produce the Colt AR-15.

Fundamental to the reliable and versatile operation of the Colt AR-15 is a new concept of design. The offset structure as well as the added weight of the long operating rod and piston found in conventional automatic weapons has been eliminated. Instead, an entirely new gas operating system using a patented bolt and bolt carrier is used. In addition to their individual functions the Colt AR-15 bolt and bolt carrier together form a unique piston and cylinder. Gas taken from a port near the muzzle is carried back thru a gas tube and fed directly into a chamber formed by the bolt and bolt carrier. The essential parts are so aligned that all forces involved are directed in a straight line from the barrel to the stock, minimizing recoil. This is one of the principles of design that assures the outstanding performance of the Colt AR-15.

The Colt AR-15 weighs approximately 6 lbs. Compared to the familiar heavier M1 rifle in weight 120 rounds of .223 ammunition are required to balance the scale. Thus a rifleman can carry an additional 120 rounds into combat at no increase in overall load.

The Colt AR-15 features a quick loading principle embodying the use of a very light weight preloaded magazine which under combat conditions is thrown away. Because of the extreme light weight of this magazine a rifleman can carry his ammunition preloaded without penalty of weight. With the use of preloaded magazines the rifleman can fire 100 rounds of .223 ammunition in 30 seconds. As soon as the magazine is emptied the release button is pushed with the finger and the empty magazine drops. Firing is instantly resumed upon insertion of the next loaded magazine. Rapid fire is wasted fire unless the weapon is controllable. The straight line stock and well balanced design of the Colt AR-15 provides ease of handling and accurate control. Recoil in the Colt AR-15 is reduced substantially. Corrosion resistant materials facilitate the assembly and interchangeability of parts and reduce the service and maintenance of the Colt AR-15 to an absolute minimum. Firing of the Colt AR-15 with complete absence of lubricants in a chemically cleaned condition has in every country where this test has taken place resulted in a performance far exceeding any requirements.

The Colt AR-15 rifle will fire longer without cleaning or oiling than any other known rifle. Another condition in which the Colt AR-15 excels is the sub zero temperature test including exposure to icing and freezing. The sand test is one that stops many of the world's best weapons, yet the Colt AR-15 has gone through the most severe of these tests without malfunction.

None of the various adverse condition tests including sand have left any ill effects on this weapon. Performance in mud is probably the most difficult of all adverse conditions, the close fitting dust cover makes it possible for the Colt AR-15 to out perform all other automatic weapons in this test.

An occasional simple cleaning will keep the weapon functioning indefinitely. Working parts can be cleaned by wiping with a cloth. The simplicity of field cleaning makes it possible to quickly and easily train a recruit in minimum time.

The carrying handle serves as a base for mounting the scope. Firearms experts are most impressed by the fact that this weapon with the fire power of a machine gun has the accuracy and dependability of the best sniper rifle.

Twenty grenade launcher cartridges fit the standard magazine, meaning that grenades can be launched in rapid succession. Only on the Colt AR-15 can this be accomplished without adjustment of any kind. Instant change from grenade launching to combat ammunition or vice versa is then provided. Quick-on-the-target performance means maximum effectiveness and less wasted ammunition on the part of the combat rifleman. This remarkable weapon is used as the basic infantry rifle, a submachine gun, a highly accurate sniper rifle. A single weapon meeting all these requirements means fewer logistics problems, simplified and shorter training programs, and a single type of ammunition.

THE AR-15 BASIC INFANTRY WEAPON

1.0 Description, General

1.1 The AR-15 is a Caliber .223, air cooled, gas operated rifle. It is fed from a 20 round magazine and may be fired from the shoulder or hip either full automatic or semi-automatic. With suitable cartridges and the grenade sight it may also be used to launch grenades.

1.2 The barrel is air cooled and is provided with a flash suppressor which also serves as a grenade launcher

and a front support for the bayonet. The barrel is surrounded by a heat resistant glass fibre material which serves as a hand guard and forearm. A heat reflecting inner shield keeps the hand guard cool.

1.3 The sights are adjustable at front and rear as explained later in 8.1 - 9.1 and 9.2.

1.4 The magazine holds 20 rounds of caliber .223 ammunition and is made entirely of non corrosive material. The butt stock is made of a synthetic material of high impact strength and is provided with a soft rubber butt plate.

1.5 Pressing the take down pin to one side permits the rifle to be opened, exposing the working parts for cleaning and inspection.

1.6 In this weapon the bolt is locked to the barrel by means of locking lugs, like small gear teeth, on the bolt. Similar lugs on the barrel extension engage the bolt lugs, holding the bolt firmly against the barrel. Thus the full force of the explosion of the cartridge is absorbed by the barrel and bolt alone. For this reason the receiver can safely be made of light-weight aluminum alloys. The safety, durability and function of the rifle is in no way reduced and the portability and logistical values greatly increased, particularly when air transport is used.

FUNCTION

2.0 Semi Automatic

2.1 The functioning of the various components during firing is as follows: With the weapon loaded and the safety set on "SEMI" fire, the trigger is pulled. The trigger rotates on the trigger pin causing the trigger sear to release the hammer. The hammer is then thrown forward by the pressure of the hammer spring, striking the firing pin which in turn causes ignition of the cartridge.

2.2 When the cartridge fires, the pressure of the explosion causes the bullet to move down the barrel. When the bullet passes the gas port, which is a small hole under the front sight, a small amount of gas is piped thru the gas tube, back into the bolt carrier. This gas, under pressure, expands in the cylinder between the bolt and bolt carrier, driving the bolt carrier to the rear. As the bolt carrier moves to the rear, the cam track in its upper surface acts upon the bolt cam pin causing it and the bolt through which it passes to rotate until the locking lugs of the bolt are no longer in line with the lugs of the Barrel extension. The bolt is now in the unlocked position and as the bolt carrier continues its rearward motion, the bolt assembly is also carried to the rear. As the bolt carrier and bolt recoils, it compresses the action spring and returns the hammer to the cocked position. By means of the extractor, which is pinned to the bolt, the expended cartridge case is withdrawn from the chamber. The ejector, also carried in the bolt, then throws the empty case out through the ejection port.

2.3 The rearward stroke of the bolt carrier is arrested by the buffer assembly and action spring guide which strikes the bottom of the receiver extension. The action spring then

forces the bolt carrier and bolt toward the chamber. On the forward stroke, the face of the bolt picks up a cartridge from the magazine and thrusts it into the chamber. As the bolt lugs enter the barrel extension the ejector is compressed against the left side of the cartridge face and the extractor snaps into the cannellure on the right side. As the bolt carrier enters the final one-half inch of its closing stroke, the bolt cam pin emerges from the bolt carrier guide channel in the upper receiver and the bolt carrier cam track then rotates the bolt counterclockwise into the locked position. This completes one loading cycle.

2.4 When the trigger is pulled, the firing action of the rifle is so much faster than human reaction that it is impossible to release the trigger quickly enough to prevent firing several shots instead of one. For this reason a "disconnect" is used to catch and hold the hammer until the trigger is pulled again for a second shot. When the trigger is pulled the disconnect is rotated forward with the trigger by the action of the disconnect spring. After firing, the hammer is cocked by the recoil of the bolt carrier and the hook of the disconnect engages the upper inside notch of the hammer, holding it back and preventing a second shot.

2.5 When the trigger is released, the trigger spring causes the trigger to return to the normal position, carrying the disconnect backward with it. The hammer is then released from the hook on the disconnect. However, before the disconnect hook actually releases the hammer, the trigger sear has moved in front of the hammer notch and the hammer drops from the disconnect to the trigger sear. The arm is then ready for a second shot.

3.0 Full Automatic

3.1 When the safety is set for full automatic fire, the trigger mechanism functions as follows:

3.2 When the trigger is pulled, the trigger sear releases the hammer. The disconnect, however, is prevented from moving forward to engage the hammer by the center cam of the safety.

3.3 After the first shot, when the hammer is moved into the cocked position by the bolt carrier, the disconnect does not catch the hammer but the notch on the top outside edge of the hammer does engage with the automatic sear. The hammer then stays in the cocked position held by the automatic sear until the bolt carrier at the end of its forward movement, strikes the upper edge of the automatic sear, causing it to release the hammer. The hammer then falls to fire the next shot of the burst. This cycle repeats itself until the magazine is emptied or the trigger is released. If the trigger is released the hammer falls from the automatic sear as described but is held by the trigger sear, thus ending the cycle of automatic fire.

3.4 When the last round from a magazine has been chambered, the magazine follower rises into contact with the bolt stop. As the bolt carrier moves to the rear following the firing of the last cartridge, the magazine follower, under the action of the magazine spring, forces the bolt stop up into the path of the bolt face, thus holding the bolt to the rear. Removal of the magazine does not release the bolt since the force of the action spring on the bolt holds the bolt stop in place. Pressing in the head of the bolt stop where it emerges through the receiver on the left hand side allows the bolt to travel home whether there is a loaded, unloaded or no magazine at all in the weapon. CAUTION - If a loaded magazine is in place, the arm

is now loaded and ready to fire.

3.5 Pressing the lower part of the bolt stop will cause the bolt to be held back when the charging handle is retracted. The weapon is now safe and open for inspection of the chamber.

3.6 Pressing the magazine Catch Button will release the magazine.

OPERATION

4.0 Loading

4.1 Press the magazine release and remove the magazine.

4.2 Pull the charging handle rearward as far as possible and release.

4.3 Set the safety on "SAFE".

4.4 Load the magazine by pressing cartridges down from the top until twenty are in place. The bullet must point toward the smooth face of the magazine with the large end of the cartridge under the magazine feed lips.

4.5 Insert the loaded magazine into the rifle, pushing upward until the catch snaps into place.

4.6 Pull the charging handle fully to the rear and release quickly allowing the bolt to move forward to battery position by the force of the action spring. If no firing is to be done immediately after charging, it is advisable to close the dust cover. This cover will open automatically when firing is commenced.

5.0 Firing

5.1 Rotate safety to "SEMI" or "AUTO" position. Squeeze trigger.

6.0 Reloading

6.1 Since the bolt and bolt carrier are held to the rear

upon emptying a magazine, reloading is simply a matter of pressing the magazine release button and replacing the empty magazine with a loaded one. When the bolt catch button on the left side of the receiver is pressed at the top the bolt will close and chamber the first round from the new magazine. The Rifle is then ready to fire again.

7.0 Unloading

- 7.1 Set safety to safe.
- 7.2 Remove magazine
- 7.3 Pull charging handle to rear.
- 7.4 Inspect chamber and bolt face.
- 7.5 Release charging handle

8.0 Sight Adjustment - Windage

8.1 Windage adjustment is made by using a bullet point to depress the detent and release the windage drum. At the same time, the windage drum may be turned one hole. Rotation of one notch in the direction of the L and the arrow will change the point of impact of the bullet one inch to the left at 100 yards (1 minute of angle). Reversing the rotation of the windage drum will cause the bullet to strike to the right the same amount.

9.0 Sight Adjustment - Elevation

9.1 Set rear sight on normal range setting for distances of 0 - 300 yards. For distances of 300 to 500 yards rotate rear sight to "L" (long range) position.

9.2 To adjust the sights for elevation, depress the front sight detent with a bullet point and rotate the sight post. Rotating the post clockwise as indicated by the arrow and word - up - will raise the point of impact; reversing the direction of rotation will lower the point of impact. Each detent notch

* 62116 BOLT ASSEMBLY CONSISTS OF:

- | | |
|-------|------------------|
| 61538 | BOLT |
| 61540 | BOLT RING |
| 61562 | EXTRACTOR |
| 61568 | EXTRACTOR SPRING |
| 61563 | EXTRACTOR PIN |
| 61564 | EJECTOR |
| 61569 | EJECTOR SPRING |
| 95102 | EJECTOR PIN |

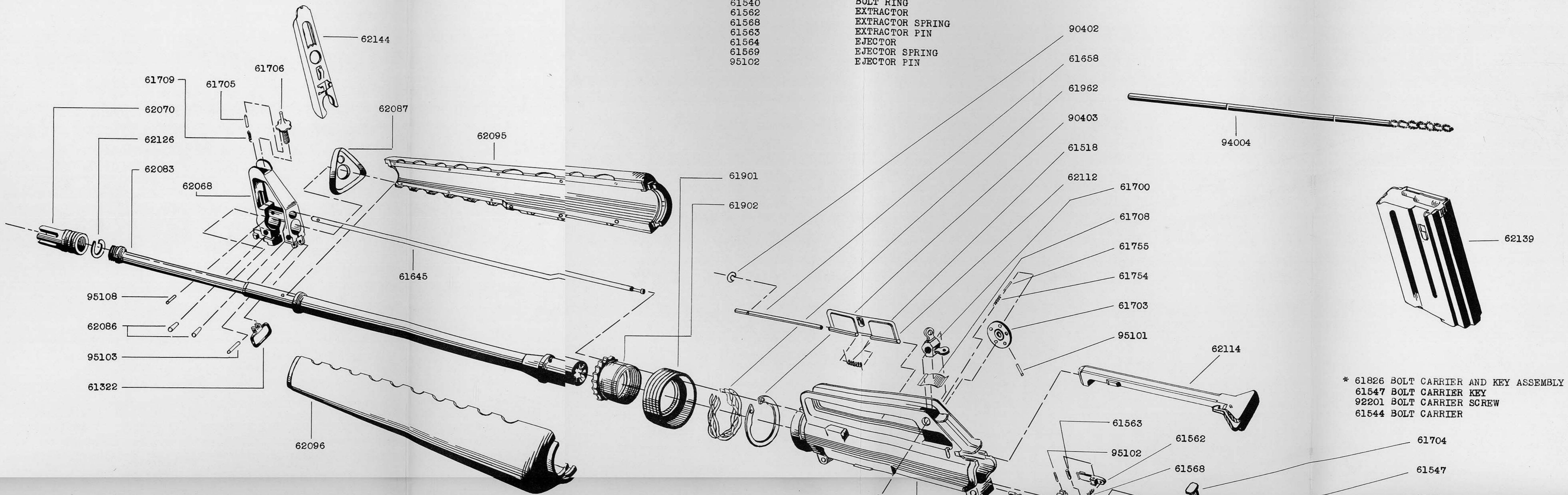

* 62119 ACTION SPRING GUIDE ASSEMBLY CONSISTS OF:

- | | |
|-------|---------------------|
| 61580 | ACTION SPRING GUIDE |
| 61578 | BUFFER RING-OUTER |
| 61579 | BUFFER RING-INNER |
| 61577 | BUFFER END RING |
| 61576 | BUFFER CAP |
| 95101 | BUFFER PIN |

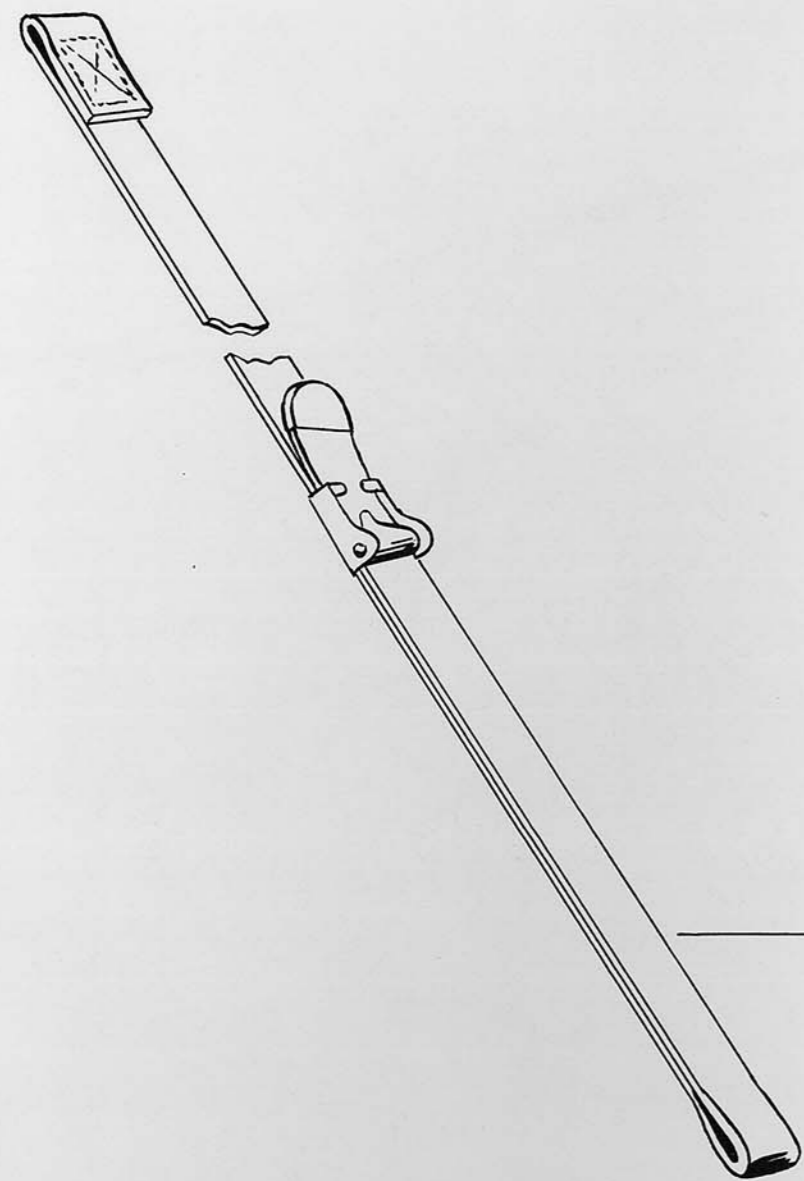

SHORT 62135
LONG 62149

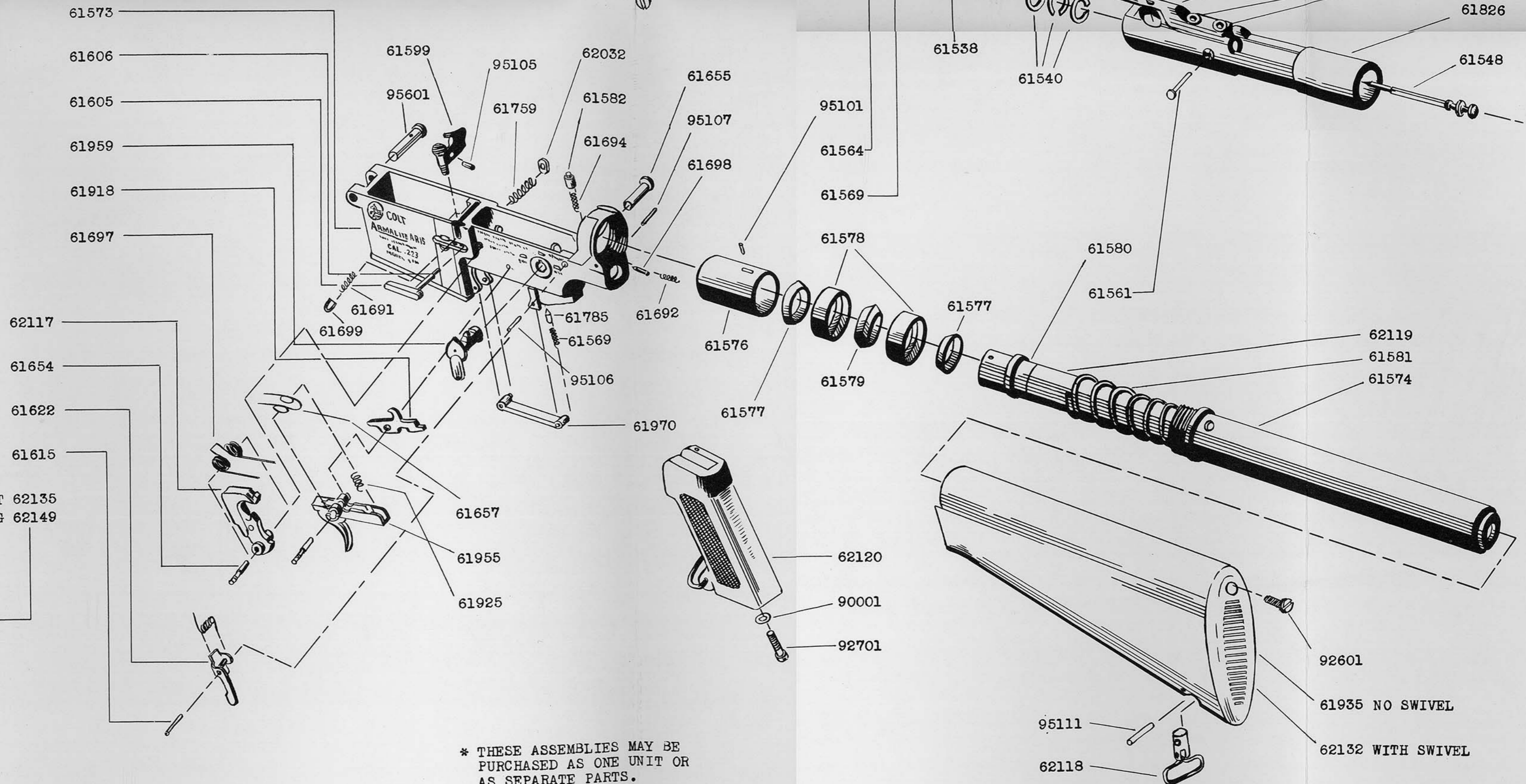

* THESE ASSEMBLIES MAY BE PURCHASED AS ONE UNIT OR AS SEPARATE PARTS.

rotated will change the point of impact 1 inch at 100 yards (1 minute of angle).

DISASSEMBLY AND ASSEMBLY

10.0 DISASSEMBLY FOR FIELD CLEANING

10.1 CAUTION! - Look in the chamber! Starting with the action closed and the safety set on safe, press the take down pin at the rear of the receiver to the right until the rear of the upper receiver is free to swing away from the lower receiver. Pull back charging handle to withdraw bolt group from receiver. With the point of a cartridge, press out the firing pin retaining pin. Shake out the firing pin. Remove the cam pin. Withdraw the bolt from the bolt carrier. Assemble in the reverse order.

10.2 To remove hand guards, pull back slip ring and lift rear end of guards out and back.

11.0 Full Field Strip

11.1 Strip as in 10.0. Press out the receiver pivot pin. Remove the charging handle and lower the hammer gently. Depress the buffer retainer plunger, allowing the buffer assembly and action spring to move forward and out of the lower receiver. CAUTION - Powerful spring! Hold buffer to prevent flying parts.

11.2 With a cartridge point, press out the hammer pin. The firing pin, gently used, may be of assistance during the last half of the hammer pin's movement.

11.3 With a cartridge point start the automatic sear pin to the left, pressing it all the way out with a tail of the hammer spring.

11.4 With the point of a cartridge press out the safety, while holding the trigger forward.

11.5 Start the trigger pin in either direction (a cartridge point can be used for this), using a tail of the hammer spring to complete its removal. Lift out the trigger and disconnect. This completes field stripping.

12.0 Reassembly Following Field Strip

12.1 Place the disconnect and trigger in the lower receiver, pressing the trigger against the trigger spring until the trigger pin can be passed through the left side of the receiver and into the trigger. Press the disconnect down against its spring until the trigger pin can be pushed all the way through. Check the movement of the trigger to see that there is no binding of the trigger spring. Using a cartridge point to depress the safety detent plunger, and holding the trigger forward, install the safety.

12.2 Set the safety in automatic position. Install the automatic sear, making sure that the tail of the automatic sear, is behind the safety and that the long tail of the automatic sear spring is in front of the safety and lying in its accommodating groove.

12.3 Press the hammer into its position, seeing that the tails of the hammer spring fall into their grooves in the trigger pin. Align the hole in the hammer with corresponding holes in the receiver and press the hammer pin in.

12.4 Insert action spring and buffer group into the receiver extension. Place the upper and lower receiver together and drive in receiver pivot pin from the right.

12.5 Assemble the bolt and bolt carrier group.

12.6 Insert the charging handle part way into the upper receiver, making sure that it is properly in its groove then place the bolt carrier key in the charging handle groove

- and push both assemblies into upper receiver.
- 12.7 Cock the hammer and set the safety to safe.
 - 12.8 Close the piece and press home the take down pin.
 - 12.9 The weapon is now reassembled.
- 13.0 Complete Disassembly
- 13.1 Proceed as in field strip, 10.0 and 11.0.
 - 13.2 Upper Receiver Group.
 - 13.3 Drive out rear sight windage drum pin, unscrew the windage screw from the aperture. Remove rear sight, sight spring, detent and spring.
 - 13.4 Unscrew flash suppressor.
 - 13.5 Unscrew front sight post, and remove detent and spring. Drive out sling swivel pin. Remove sling swivel. Drive out front sight pins. Drive front sight forward off the barrel.
 - 13.6 Drive out gas tube pin and remove tube.
 - 13.7 Using appropriate wrench, unscrew barrel nut. Slide barrel from upper receiver.
 - 13.8 Drive dust cover pin forward. Remove dust cover and spring. Note: - Dust cover can be removed at any time by removing the small "C" washer from the pivot pin and sliding the pin to the rear.
- 14.0 Charging Handle Group
- 14.1 Drive out retaining pin. Remove latch and spring.
- 15.0 Lower Receiver Group
- 15.1 Remove bolt catch by driving the pivot pin forward. The thumb piece can then be removed. Do not loose spring and plunger. Depress magazine catch button as far as it will go. Rotate magazine catch plate unscrew from catch button. Remove magazine catch, button and spring.

15.2 Depress trigger guard plunger and swing trigger guard down. Drive out trigger guard pin. Remove trigger guard. Drive out trigger guard plunger retaining pin. Remove trigger guard plunger and spring.

15.3 Unscrew and remove pistol grip screw. Remove pistol grip. Be careful not to loose safety detent and spring. Unscrew and remove butt cap screw. Remove butt stock making certain that the hinge pin detent and springs are not lost. Drive out swivel assembly roll pin, remove swivel assembly.

16.0 Buffer Group

16.1 Drive buffer pin into action spring guide. Separate buffer, buffer rings, and action spring guide, carefully noting the order in which they are assembled.

16.2 It is not considered advisable for any personnel other than fully qualified base ordnance personnel to separate the lower receiver and receiver extension.

16.3 NEVER: - separate the barrel and barrel extension.

REPLACEMENT OF PARTS

17.0 Two safeties are available for the AR-15 rifle. One having a solid thumb piece is standard equipment and will permit automatic fire when the pointer is on "AUTO". The other safety has a notched thumb piece for recognition in the dark. This safety will not permit automatic fire in any position. To interchange these parts open the rifle as in 10.1 but it is not necessary to disassemble the bolt carrier. Remove the hammer as in 11.2 and the automatic sear as in 11.3. With the safety in "SAFE" position and holding the trigger forward, hold the detent down with a tool or cartridge point and install the new safety.

Re-assemble the automatic sear and hammer as in 12.2 and 12.3. Be sure the hammer spring ends are resting on the trigger pin and the automatic sear spring end is in the groove in the safety.

18.0 Barrel Replacement

18.1 Open rifle, remove bolt assembly and charging handle as in 10.1.

18.2 Drive out pivot pin and separate upper and lower receiver.

18.3 Remove handguards as in 10.2.

18.4 Unscrew flash suppressor.

18.5 Drive out two taper pins and remove front sight, gas tube and hand guard cap.

18.6 Hold upper receiver in suitable vise and unscrew barrel nut.

18.7 Remove barrel assembly. NOTE: - Never remove the barrel extension from the barrel. (The chamber depth on each barrel assembly is measured from the barrel extension).

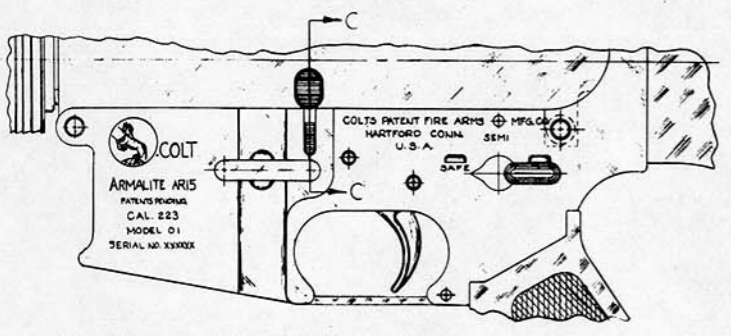

VIEW SHOWING SAFETY AND BOLT CATCH

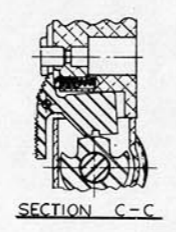

SECTION C-C

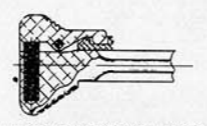

VIEW SHOWING CHARGING HANDLE

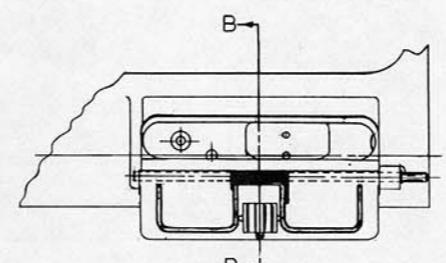

VIEW LOOKING AT EJECTOR

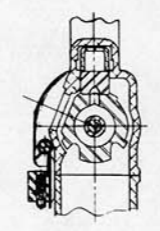

SECTION B-B

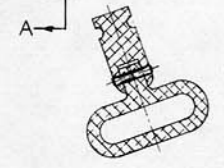
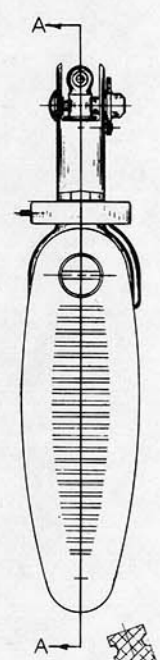

SECTION D-D THRU SLING

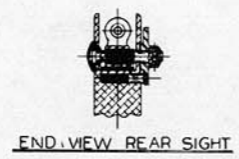

END VIEW REAR SIGHT

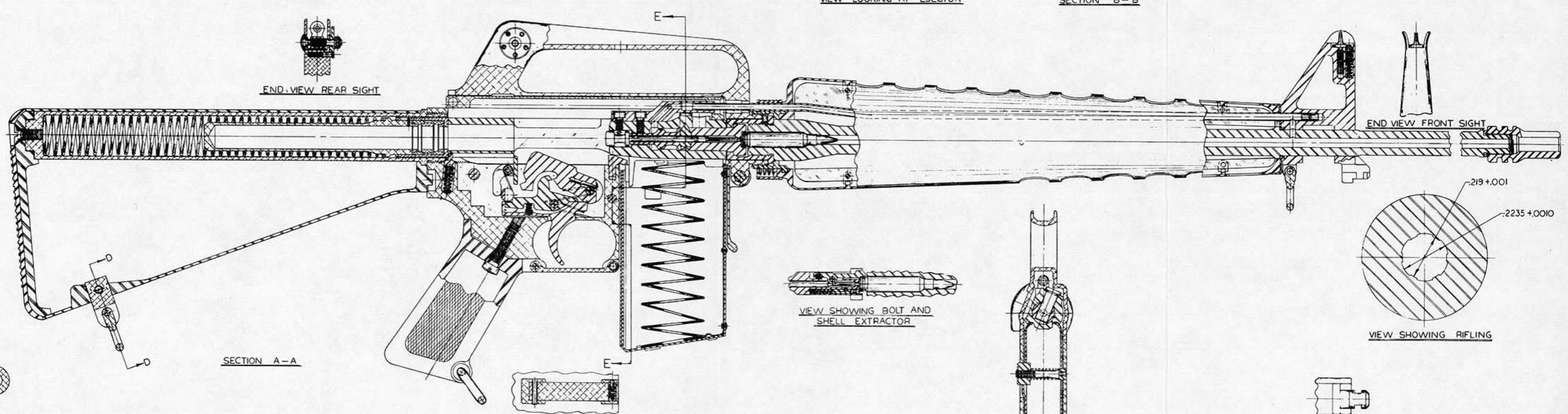

SECTION A-A

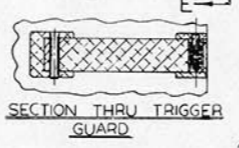

SECTION THRU TRIGGER GUARD

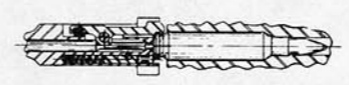

VIEW SHOWING BOLT AND SHELL EXTRACTOR

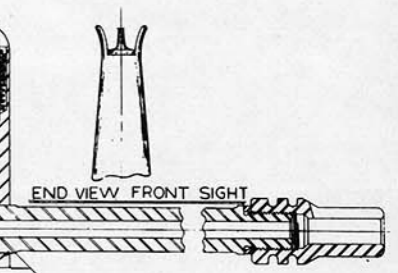

END VIEW FRONT SIGHT

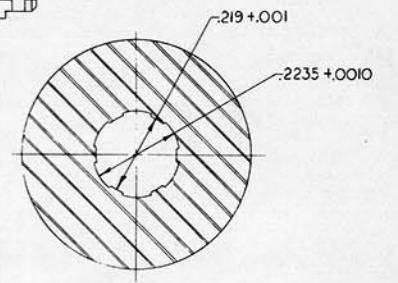

VIEW SHOWING RIFLING

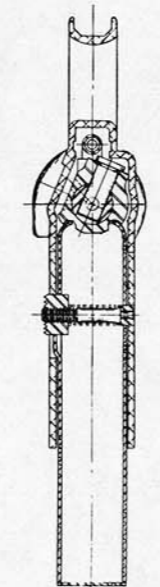

SECTION E-E THRU BOLT CAM AND MAGAZINE RELEASE

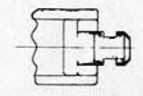

VIEW SHOWING BAYONET HOLDER

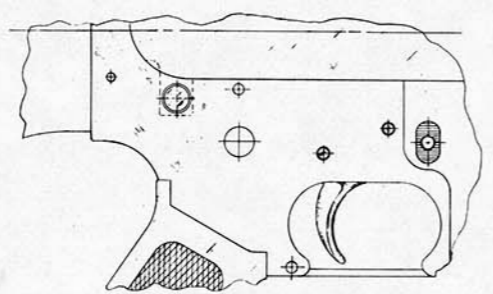

VIEW SHOWING MAGAZINE RELEASE

GUN ASSEMBLY

COLT-ARMALITE

AR-15

Automatic Military Rifle
Caliber .223

PARTS, ACCESSORIES LIST AND
ARMORER'S KIT

COLT'S PATENT FIRE ARMS MANUFACTURING COMPANY, INC.
HARTFORD 15, CONN.
U. S. A.

February, 1960

Determination of specific requirements should take into account conditions of climate and terrain, transportation time, extraordinary usage such as endurance testing and actual warfare, and the number of service depots at which spare parts will be stocked. This List is presented in three Sections:

Section I - Parts

Section II - Accessories

Section III - Armorer's Kit

SECTION I - Parts

Part No.	Name
61546	Receiver - Upper
62112	Ejection Port Cover Assembly
61658	Ejection Port Cover Pin
90402	Ejection Port Cover Pin Retaining Ring
61518	Ejection Port Cover Spring
61700	Rear Sight
61708	Rear Sight Spring
61702	Rear Sight Windage Screw
61703	Rear Sight Windage Drum
61755	Rear Sight Detent
95101	Rear Sight Windage Drum Pin
61754	Rear Sight Detent Spring
62083	Barrel Assembly
61902	Barrel Nut
61901	Hand Guard Slip Ring
61962	Hand Guard Slip Ring Spring Assembly
90403	Hand Guard Snap Ring
61645	Gas Tube Detail Assembly (Completed and Bent)
95108	Gas Tube Pin
62087	Hand Guard Cap
62068	Front Sight
62086	Front Sight Taper Pins
62096	Hand Guard Assembly LH
62095	Hand Guard Assembly RH
61706	Front Sight Post
61705	Front Sight Detent
61709	Front Sight Detent Spring
61322	Front Swivel
95103	Front Swivel Pin
62070	Flash Suppressor
62126	Flash Suppressor, Lock Washer
62114	Charging Handle Assembly
61826	Bolt Carrier and Key Assembly
61547	Bolt Carrier Key
92201	Socket Head Cap Screw

Part No.	Name
62116	Bolt Assembly
61538	Bolt
61540	Bolt Ring
61562	Extractor
61568	Extractor Spring
61563	Extractor Pin
61564	Ejector
61569	Ejector (and Safety Detent Spring)
95102	Ejector Pin
61704	Bolt Cam Pin
61548	Firing Pin
61561	Firing Pin Retaining Pin
61573	Lower Receiver *
61574	Lower Receiver Extension
95107	Lower Receiver Extension Pin
61970	Trigger Guard Assembly
95106	Trigger Guard Pivot Pin
61605	Magazine Catch Plate
61606	Magazine Catch Shaft
61759	Magazine Catch Spring
62032	Magazine Catch Button
61599	Bolt Catch
61699	Bolt Catch Plunger
61691	Bolt Catch Spring
95105	Bolt Catch Pin
61955	Trigger
61657	Trigger Spring
61654	Trigger Pin (and Hammer Pin)
61918	Disconnect
61925	Spring Disconnect
62117	Hammer Assembly
61654	Hammer Pin (and Trigger) See Trigger Pin
61697	Hammer Spring
61622	Automatic Sear Assembly
61615	Automatic Sear Pin
61582	Buffer Retainer
61694	Buffer Retainer Spring
61655	Takedown Pin
61698	Takedown Pin Detent
61692	Takedown Pin Detent Spring

* Has serial number. Sold only on return of used receiver.

Part No.	Name
61935	Stock Assembly Molded (No Swivel)
62132	Stock Assembly Molded (With Swivel)
92601	Butt Cap Screw
62119	Action Spring Guide Assembly
65180	Action Spring Guide
61578	Buffer Ring - Outer
61579	Buffer Ring - Inner
61577	Buffer End Rind
61576	Buffer Cap
95101	Buffer Pin
61581	Action Spring
61959	Safety
61785	Safety Detent
61569	Safety Detent Spring (and Ejector) See Ejector Spring
62120	Pistol Grip Assembly
92701	Pistol Grip Screw
90001	Lockwasher
95601	Receiver Pivot Pin Assembly
62139	Magazine Assembly, Stainless Steel (20 rounds of .223)
94004	Cleaning Rod Assembly
91206	Cleaning Brush
62135	Sling Pistol Grip
62214	Grenade Sight (ATK - 75 mm.)

SECTION II -- ACCESSORIES

<u>PART NO.</u>	<u>NAME</u>
62122	Bipod Assembly
62137	Bipod Case
62082	Bayonet Assembly
62138	Bayonet Scabbard
62133	Safety, Non-Automatic Fire
62132	Butt Stock Assembly with Swivel
62118	Rear Swivel Assembly (Butt)
95111	Roll Pin - Rear Swivel
62149	Sling - Butt Stock
62215	Scope Mount Assembly
62142	Scope Assembly
62136	Scope Case

SECTION III - ARMORER'S INSPECTION AND REPAIR KIT

<u>PART NO.</u>	<u>NAME</u>
T 27823	Barrel Remover Fixture
T 27672	Adapter
T 27669	Protrusion Gage Firing Pin
T 27921	Head Space Gage (Field Type)
T 27670	Maximum Bore Gage
T 27442	Bore Drop Plug
T 27726	Fixture Sight Removal and Realignment