

Gesoke Guns

TM 9-1005-249-34

DEPARTMENT OF THE ARMY TECHNICAL MANUAL

DIRECT SUPPORT AND GENERAL SUPPORT MAINTENANCE MANUAL
INCLUDING REPAIR PARTS AND SPECIAL TOOLS LIST
(INCLUDING DEPOT MAINTENANCE REPAIR PARTS AND
SPECIAL TOOLS)

RIFLE, 5.56-MM, M16
(1005-856-6885)

RIFLE, 5.56-MM, M16A1, W/E
(1005-073-9421)

AND

BIPOD, RIFLE, M3, W/CARRYING CASE
(1005-890-2609)

HEADQUARTERS, DEPARTMENT OF THE ARMY
FEBRUARY 1972

Digitized by:

WARNING

DANGEROUS CONDITIONS

When using P-C-111, avoid skin contact. If it comes in contact with the skin wash off thoroughly with running water. The usage of a good lanolin base cream after exposure to compound is helpful. The use of gloves and protective equipment is recommended.

DANGEROUS PROCEDURES

Before starting an inspection, be sure to clear the rifle. Do not actuate the trigger until the rifle has been cleared. Inspect the chamber to insure that it is empty and that no ammunition is in position to be chambered. Avoid having live ammunition in vicinity of work area.

Be careful when removing spring loaded components, for injury to personnel could result.

When mixing and using solid film lubricant and dichloromethane, make certain the area is well ventilated. When preparing and using copper de-fouling solution make certain to do so in a well ventilated area. Do not allow this solution to make contact with eyes, mouth or open wound. Rubber gloves should be worn to protect hands and if spills are likely to occur, usage of eye shields, rubber aprons and shoe protection is necessary. After usage the solution should be disposed of, in small quantities through normal sewerage system (small quantities less than 2 or 3 gallons at a time.)

Technical Manual

No. 9-1005-249-34

HEADQUARTERS,
DEPARTMENT OF THE ARMY
Washington, D.C., 10 February 1972

**DIRECT SUPPORT AND GENERAL SUPPORT MAINTENANCE MANUAL
INCLUDING REPAIR PARTS AND SPECIAL TOOLS LIST
(INCLUDING DEPOT MAINTENANCE REPAIR PARTS AND SPECIAL TOOLS)**

**RIFLE, 5.56-MM, M16 AND
RIFLE, 5.56-MM, M16A1
AND
BIPOD, RIFLE, M3**

This manual is current as of 12 January 1972

	Paragraphs	Pages	Illus Figure
CHAPTER 1. INTRODUCTION			
Section I. General	1-1—1-3	5	
II. Description and data	1-4—1-5	5	
CHAPTER 2. DIRECT SUPPORT AND GENERAL SUPPORT MAINTENANCE INSTRUCTIONS			
Section I. Repair parts, special tools, and equipment	2-1—2-2	9	
II. Troubleshooting	2-3	10	
III. Preembarkation inspection of material in units alerted for overseas movement	2-4	11	
IV. General maintenance	2-5—2-9	11	
CHAPTER 3. REPAIR INSTRUCTIONS			
Section I. Repair instructions	3-1	13	
II. Maintenance inspections	3-2—3-8	34	
III. Replacement of parts	3-9	41	
CHAPTER 4. MAINTENANCE OF MATERIEL USED IN CONJUNCTION WITH MAJOR ITEM	4-1—4-2	43	
CHAPTER 5. FINAL INSPECTION	5-1	45	
APPENDIX A. REFERENCES	A-1—A-4	47	
APPENDIX B. DIRECT SUPPORT AND GENERAL MAINTENANCE REPAIR PARTS AND SPECIAL TOOLS LIST (INCLUDING DEPOT MAINTENANCE REPAIR PARTS AND SPECIAL TOOLS)	B-1—B-5	49	
Section II. Repair parts list			
RIFLES, 5.56-MM, M16 and M16A1			B-1
Upper receiver group			B-2
Bolt carrier group			B-3
Lower receiver group			B-4
Small arms cleaning rod, M11E3			B-5
Section III. Special tools list			
Tools and Equipment authorized for Unit Replacement			1-3, B-5, B-6, B-7, B-15
Special Tools and Equipment			B-8, B-9, B-10, B-11, B-12, B-13, B-14 64
Section IV. Federal stock number and reference number index			

*This manual supersedes TM 9-1005-249-34, 20 August 1968, including all changes.

List of Illustrations

Number	Title	Page
1-1.	Rifle, 5.56-MM, M16—right rear view.	5
1-2.	Rifle, 5.56-MM, M16A1—right rear view.	6
1-3.	Rifle Bipod, M3 with carrying case.	7
2-1.	Fabricated tool for removing and installing front sight post.	9
2-2.	Fabricated barrel cap.	10
3-1.	Disassembly/assembly of magazine assembly.	16
3-2.	Disassembly/assembly of upper receiver group. (1 of 6)	17
3-2.	Disassembly/assembly of upper receiver group. (2 of 6)	18
3-2.	Disassembly/assembly of upper receiver group. (3 of 6)	19
3-2.	Disassembly/assembly of upper receiver group. (4 of 6)	20
3-2.	Disassembly/assembly of upper receiver group. (5 of 6)	21
3-2.	Disassembly/assembly of upper receiver group. (6 of 6)	21
3-3.	Repairable/non-repairable hand guards.	22
3-4.	Gas port covered and fabricated barrel cap installed.	23
3-5.	Disassembly/assembly of bolt carrier group.	23
3-6.	Disassembly/assembly of lower receiver group. (1 of 5)	24
3-6.	Disassembly/assembly of lower receiver group. (2 of 5)	25
3-6.	Disassembly/assembly of lower receiver group. (3 of 5)	26
3-6.	Disassembly/assembly of lower receiver group. (4 of 5)	27
3-6.	Disassembly/assembly of lower receiver group. (5 of 5)	27
3-7.	Procedures for re-working old and new receiver extensions.	28
3-8.	Location of hole for drilling into spring cavity.	29
3-9.	Repairable/non-repairable stock assemblies.	29
3-10.	Repairable and non-repairable upper receivers—right side view.	31
3-11.	Critical areas of stock assembly and hand guard.	34
3-12.	Checking barrel erosion.	35
3-13.	Visually inspecting the chamber using reflector tool.	35
3-14.	Checking headspace with headspace gage.	36
3-15.	Check bolt with firing pin protrusion gage.	36
3-16.	Repairable and non-repairable lower receivers—right side view.	36
3-17.	Repairable and non-repairable lower receivers—end view.	37
3-18.	Repairable and non-repairable lower receiver extension—right side view.	38
4-1.	Bayonet-Knife, M7—exploded view.	39
4-2.	Bayonet-knife—marking and identification of releases.	40
B-1.	Magazine assembly.	56
B-2.	Upper receiver group—exploded view.	57
B-3.	Bolt carrier group—exploded view.	58
B-4.	Lower receiver group—exploded view.	59
B-5.	Tools and equipment.	60
B-6.	Tools and equipment.	61
B-7.	Tools and equipment.	61
B-8.	Headspace gage (field type).	62
B-9.	Firing pin protrusion gage.	62
B-10.	Barrel remover fixture.	62
B-11.	Combination wrench.	62
B-12.	Barrel erosion gage.	62
B-13.	Tools and equipment.	63
B-14.	Bore straightness gage.	63
B-15.	Maintenance equipment case.	63

CHAPTER 1

INTRODUCTION

Section I. GENERAL

1-1. Scope

These instructions are in accordance with the Maintenance Allocation Chart (MAC) and are published for the use of direct and general support maintenance personnel maintaining the 5.56-MM Rifles, M16, M16A1, and Rifle Bipod, M3. They provide information on the maintenance of the materiel which is beyond the scope of the tools, equipment, personnel, or supplies normally available to operators and organizational maintenance.

1-2. Maintenance Forms and Records

Maintenance forms, records and reports which

are to be used by maintenance personnel at all maintenance levels are listed in and prescribed by TM 38-750.

1-3. Reporting of Errors

Report of errors, omissions, and recommendations for improving this publication by the individual user is encouraged. Reports should be submitted on DA Form 2028 (Recommended Changes to Publications) and forwarded direct to: Commanding General, U.S. Army Weapons Command, ATTN: AMSWE-MAP, Rock Island, Illinois 61201.

Section II. DESCRIPTION AND DATA

1-4. Description

The rifles (figs 1-1 and 1-2) are light-weight, air-cooled, gas-operated, magazine-fed, shoulder or hip

fired weapons and are designed for semi or automatic fire and utilize a 30-round magazine and Rifle Bipod, M3 (fig 1-3).



WE 69298

Figure 1-1. Rifle, 5.56-MM-right rear view.



WE 68921

Figure 1-2. Rifle, 5-56-MM, M16A1-right rear view.

1-5. Tabulated data

a. Refer to TM 9-1005-249-20.

b. Additional data necessary for direct and general support maintenance is as follows:

Trigger pull, maximum8.5 lbs

Trigger pull, minimum5.0 lbs

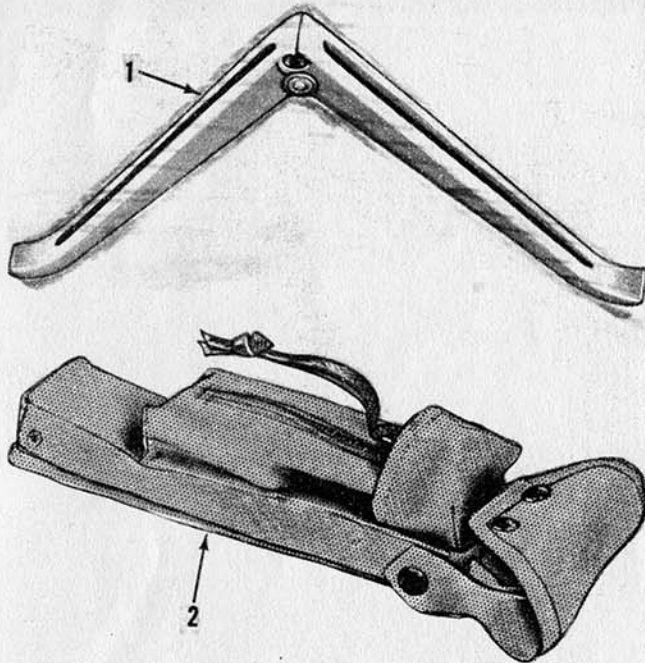

WE 60214

Figure 1-3. Rifle Bipod, M3 with carrying case.

CHAPTER 2

DIRECT SUPPORT AND GENERAL SUPPORT MAINTENANCE INSTRUCTIONS

Section I. REPAIR PARTS, SPECIAL TOOLS, AND EQUIPMENT

2-1. Repair Parts

Repair parts are listed and illustrated in appendix B.

2-2. Special Tools and Equipment

Refer to table 2-1 for special tools and equipment (including fabricated items) required to perform repair operations described in this manual.

Table 2-1. Special Tools and Equipment (Including Fabricated Items)

Item	FSN or reference No.	Reference		Use	Fig**
		Fig No	Para No		
FIXTURE, BARREL REMOVER:	4933-070-9151	3-2 and B-10		Used with combination wrench to remove /install flash suppressor and barrel nut assembly.	
GAGE, BARREL EROSION:	4933-912-3409	3-12 and B-12		To check barrel erosion for remaining barrel life.	
GAGE, BORE, STRAIGHTNESS:	4933-221-9391	B-14	Table 3-3	To check straightness of barrel bore.	
GAGE, FIRING PIN PROTRUSION:	4933-070-7815	3-15 and B-9		To check firing pin protrusion.	
GAGE, HEADSPACE:	4933-070-7814	3-14 and B-8		To gage headspace.	
REFLECTOR TOOL, CHAMBER:	4933-800-7508	3-13, 2 and B-13		To visually inspect the chamber.	
WRENCH, COMBINATION:	4933-070-9152	3-2 and B-11		To remove and install barrel nut assembly, flash suppressor and lower receiver extension.	
TOOL, FRONT SIGHT POST, REMOVING AND INSTALLING		3-2		To remove/install and adjust front sight post.	2-1
CAP, BARREL, FABRICATED		3-4	Table 3-1	To cap muzzle end of barrel to keep decoppering solution above end of barrel.	2-2

**Fabrication drawings in this manual

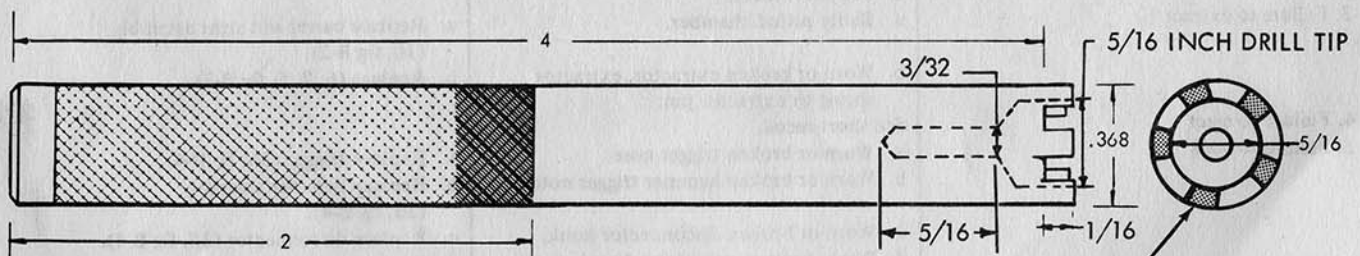

NOTE: ALL DIMENSIONS SHOWN ARE IN INCHES.

5 EQUALLY SPACED TEETH .070 WIDE

MATERIAL: MILD STEEL

Figure 2-1. Fabricated tool for removing and installing front sight post.

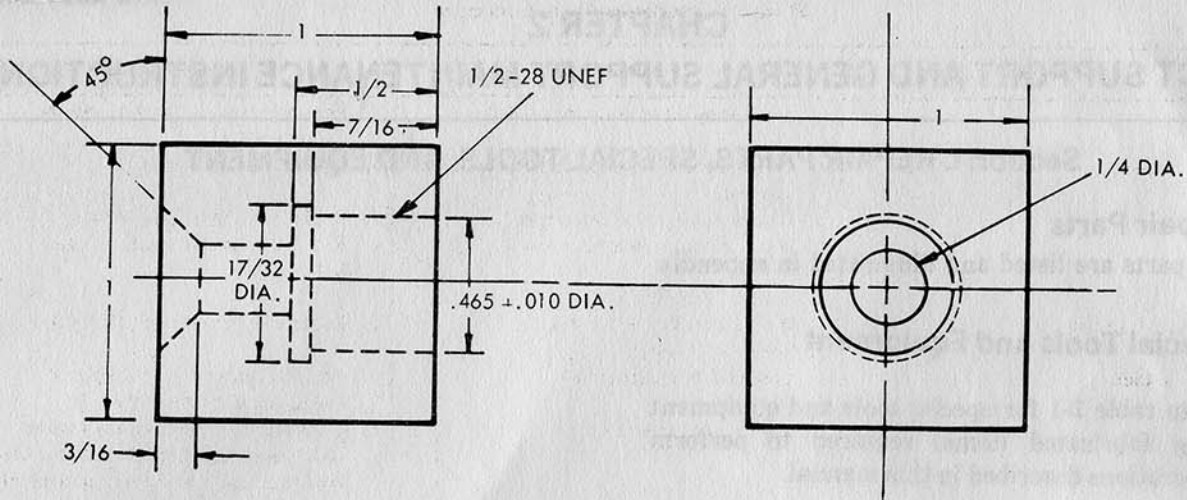

MATERIAL: 1 INCH SQUARE PLASTIC, PHENOLIC OR HARDWOOD.
 NOTE: DO NOT USE ALUMINUM, BRASS OR COPPER MATERIAL.

NOTE: ALL DIMENSIONS SHOWN ARE IN INCHES.

WE 65402

Figure 2-2. Fabricated barrel cap.

Section II. TROUBLESHOOTING

2-3. General

a. This section provides information for diagnosing and correcting unsatisfactory operation or failure of the rifles and their components. Malfunctions which may occur are listed in table 2-2. Each mal-

function stated is followed by a list of probable causes of the trouble. The corrective action recommended is described opposite the probable cause.

b. For additional data on troubleshooting refer to TM 9-1005-249-20.

Table 2-2. Troubleshooting

Malfunction	Probable cause	Corrective action
1. Failure to fire	a. Weak or broken hammer spring. b. Hammer spring improperly assembled. c. Selector lever frozen on SAFE position. d. Broken firing pin. e. Broken retaining pin.	a. Replace spring. (31, fig B-4). b. Reassemble correctly. (fig. 3-6) c. Disassemble and clean. d. Replace (2, fig B-3). e. Replace (1, fig B-3).
2. Failure to unlock	a. Burred locking lugs on bolt assembly. b. Burred locking lugs on barrel extension c. See short recoil.	a. Remove burs. b. Remove burs.
3. Failure to extract	a. Badly pitted chamber. b. Worn or broken extractor, extractor spring or extractor pin. See short recoil.	a. Replace barrel and sight assembly (10, fig B-2). b. Replace (6, 7, 5, fig B-3).
4. Failure to eject	a. Worn or broken trigger nose. b. Worn or broken hammer trigger notch.	a. Replace trigger (36, fig B-4). b. Replace hammer assembly (30, fig B-4).
5. Failure to cock	c. Worn or broken disconnecter hook. d. Weak, broken, or missing disconnecter spring. e. Worn or broken hammer disconnecter hook. f. Worn or broken hammer sear hook. g. Worn, broken or missing sear. h. Weak or broken sear spring.	c. Replace disconnecter (35, fig B-4). d. Replace spring (38, fig B-4). e. Replace hammer, assembly (30, fig B-4). f. Replace hammer assembly (30, fig B-4). g. Replace sear (33, fig B-4). h. Replace sear (33, fig B-4).

Table 2-2. Troubleshooting—Continued

Malfunction	Probable cause	Corrective action
6. Failure to feed	i. Sear spring incorrectly assembled. a. Dirty or corroded magazine catch assembly. b. Defective magazine catch spring. c. Worn or broken magazine catch.	i. Remove sear (33, fig B-4) and install correctly. a. Disassemble and clean. b. Replace spring (45, fig B-4). c. Replace magazine catch (43, fig B-4).
7. Failure to chamber	d. See short recoil. a. Weak or broken action spring. b. See short recoil.	a. Replace action spring (25, fig B-4).
8. Failure to lock	a. Damaged bolt carrier key. b. Loose bolt carrier key.	a. Replace carrier key (15, fig B-3) and check alinement (fig 3-2). b. Disassemble to remove any carbon which may have deposited under the key, reassemble and check alinement (fig 3-5).
9. Short recoil	c. Bent gas tube. d. Weak or broken action spring. e. See short recoil. a. Missing or broken bolt rings. b. Broken or bent gas tube. c. Gas tube spring pin missing from front sight. d. Partially plugged gas system because of carbon build up in the gas tube. e. Carbon build up in the narrow passage of the bolt carrier key. f. Carbon build up in barrel gas port.	c. Replace gas tube (14, fig B-2) check alinement (fig 3-2). d. Replace action spring (25, fig B-4). a. Replace rings and stagger gaps (fig 3-5). b. Replace gas tube (14, fig B-2). c. Replace spring pin (13, fig B-2). d. Replace gas tube (14, fig B-2). e. Disassemble and clean (fig 3-5). f. Remove carbon build up with a hand held No. 43 (0.089) drill.
10. Bolt fails to lock to the rear after the last round	a. Broken bolt catch. b. Weak or broken bolt catch spring.	a. Replace catch (40, fig B-4). b. Replace spring (42, fig B-4).
11. Rifle cannot be zeroed	a. Restricted movement of bolt catch. b. Defective barrel and sight assembly. c. Corroded front or rear sights. d. Accumulation of copper deposits in the lands and grooves of barrel.	a. Disassemble and clean (fig 3-6). b. Replace barrel and sight assembly (10, fig B-2). c. Disassemble, clean and lubricate (fig 3-2). d. Remove by using copper defouling solution. (See table 3-1).
12. Failure to cycle with selector lever set at automatic.	a. Broken automatic sear or spring. b. Faulty selector lever.	a. Replace sear (33, fig B-4). b. Replace selector lever (34, fig B-4).
13. Fires with selector lever on SAFE or when trigger is released with selector lever on semi	a. Worn or broken hammer trigger nose. b. Worn or broken hammer trigger notch.	a. Replace trigger (36, fig B-4). b. Replace hammer assembly (30, fig B-4).

Section III. PREEMBARKATION INSPECTION OF MATERIEL IN UNITS ALERTED FOR OVERSEAS MOVEMENT

2-4. General

Refer to TB 9-1000-247-35.

Section IV. GENERAL MAINTENANCE

2-5. General

This section contains those repair instructions which are general in nature and do not apply to one specific assembly or component.

2-6. Assembly and Disassembly

a. When assembling or disassembling the M16 and M16A1 Rifles the following procedures must be observed.

WARNING

Exercise care in removing spring loaded components as injury to personnel or damage to components may result.

b. Refer to figures 3-1 and 3-2 for assembly and disassembly procedures.
c. Remove and install all pins with a light tapping

action using the appropriate size pin punch and hammer.

2-7. Repair

All repair maintenance shall be done with standard service equipment by direct support and general support maintenance personnel trained in the use of such equipment. For specific repair instructions see table 3-1.

2-8. Cleaning and Lubrication

Cleaning and lubrication shall be performed in accordance with instructions provided in table 3-2.

2-9. Maintenance Supplies and Materials

TM 9-1005-249-20 lists lubricating, cleaning, and maintenance supplies and materials utilized by the operator and/or organizational maintenance for the rifles. The expendable supplies and materials listed in table 2-3 are only authorized to direct support

and general support maintenance. Pertinent authorized documents are the proper requisitioning authority for these items.

Table 2-3. DS/GS Maintenance Supplies and Materials

Federal Stock No.	Description
8040-944-7292	ADHESIVE KIT, METAL: A4 METAL SET
6810-234-8358	AMMONIUM CARBONATE:
6810-243-4436	AMMONIUM HYDROXIDE, ACS:
6810-234-8360	AMMONIUM PERSULFATE, ACS:
8010-811-1845	COATING, COMPOUND, FLUORESCENT: RED ORANGE FOR DIRECT APPLI- CATION (1 PT CAN)
8030-670-8553	COMPOUND, MOLDING: DEVRON DICHLOROMETHANE, THENICAL:
6810-244-0290	5—GAL PAIL
6810-616-9188	600—LB DRUM
8010-527-2884	LACQUER: BLACK (JET), 1 GAL CAN, ACRYLIC NITROCELLULOSE, PIGMENTED, LUSTERLESS
9150-142-9309	LUBRICANT, SOLID FILM: 12—OZ CAN
9150-142-9361	1—GAL CAN

CHAPTER 3 REPAIR INSTRUCTIONS

Section I. REPAIR OF MAJOR GROUPS AND ASSEMBLIES

3-1. General

a. This section contains repair instructions authorized direct and general support maintenance in the removal, installation, disassembly, assembly,

cleaning and lubrication, and repair of major groups and assemblies for Rifles M16, M16A1 and Rifle Bipod, M3.

b. Refer to table 3-1.

Table 3-1. Guide to Maintenance Functions

Item	Removal/ installation	Disassembly/ assembly	Cleaning and lubrication	Repair
Magazine assembly	Refer to TM 9-1005-249-20.	Refer to figure 3-1.	Refer to table 3-2.	Refer to section III.
Upper receiver group	Refer to TM 9-1005-249-20.	Refer to figure 3-2.	Refer to TM 9-1005-249-20. and table 3-2.	<p>1. Refer to section III.</p> <p>2. Upper receivers that are corroded (B, fig 3-10) should be cleaned as indicated in table 3-2 and repaired as follows:</p> <p style="margin-left: 20px;">a. Apply molding compound, 8030-670-8553, mixed in accordance with manufacturer's directions, to areas to be filled as indicated in B, figure 3-10.</p> <p style="margin-left: 20px;">b. Spread molding compound, as smooth as possible, into defective area using a putty knife or similar tool.</p> <p style="text-align: center;">NOTE</p> <p style="margin-left: 40px;">Do not feather edge.</p> <p style="margin-left: 20px;">c. Place a sheet of polyethylene, cut to size, over filled area. Rub by hand or smooth using a small roller.</p> <p style="margin-left: 20px;">d. After curing, remove polyethylene sheet in accordance with instructions by the manufacturer.</p> <p style="margin-left: 20px;">e. Spray a coat of solid film lubricant, 9150-142-9309, in accordance with instructions supplied by the manufacturer. Allow to dry 24 hours before usage. Adequate ventilation is recommended.</p> <p style="text-align: center;">CAUTION</p> <p>Solid film lubricant is to be used only as an exterior surface protective finish and touch up. If solid film lubricant comes in contact with recoiling parts or function surfaces of the rifles, remove immediately by washing with thenical dichloromethane.</p> <p style="margin-left: 20px;">f. When one gallon of solid film lubricant, 9150-142-9361, is used, mix with one gallon of thenical dichloromethane, 6810-244-0290. This will refinish approximately 200 rifles. This mixture should not be used as a dip process.</p> <p style="text-align: center;">WARNING</p> <p>Use in a well ventilated area.</p> <p style="text-align: center;">NOTE</p> <p>For repairing corroded areas (B, fig 3-10) without usage of filler, refer to TM 9-1005-249-20.</p> <p>Rifles which have been re-barreled are required to be function fired with nine rounds of ball ammunition. After re-barreling, the rifle must be targeted with three rounds of ball ammunition at 25 meter range, using target, 6920-906-0169. (Refer to TM 9-1005-249-10 and FM 23-9.)</p>

Table 3-1. Guide to Maintenance Functions — Continued

Item	Removal/ installation	Disassembly/ assembly	Cleaning and lubrication	Repair
Upper receiver group—Cont				<p>3. Hand guards containing punctures, dents, gouges, and crushed areas not exceeding two inches in length and 1/2 inch in diameter, at the widest point (A, fig 3-3) can be repaired using adhesive, 8040-944-7292, and the same procedures as for the stock assembly. See TM 9-1005-301-30. Hand guards badly damaged, as indicated in B, fig 3-3, will be replaced.</p> <p>4. For barrels that contain metal fouling or coppering, repair as follows:</p> <ul style="list-style-type: none"> a. Remove the handguards, separate the upper receiver and barrel assembly from the lower receiver. Remove the bolt carrier group, charging handle, flash suppressor, washer, front sight, gas tube, and hand guard cap. b. After removal, of above groups and parts, cover the gas port with masking tape (fig 3-4) and insert a small cork (size "0") in the chamber end of barrel bore. Fabricate a cap (fig 2-2) to screw on muzzle end of the barrel (fig 3-4). The cap will provide a means for keeping the solution above the end of the barrel. c. After the barrel has been prepared, the copper de-fouling solution must be mixed as follows: <p style="text-align: center;">NOTE</p> <p>It is recommended the solution be mixed a day in advance to insure that the ingredients are completely dissolved.</p> <p style="text-align: center;">WARNING</p> <p>When preparing and using this solution make certain it is used in a well ventilated area due to the presence of ammonia fumes. Do not allow solution to make contact with eyes, mouth, or open wound. Rubber gloves should be worn to protect hands. If spills are likely to occur, the usage of eye shields, rubber aprons and shoe protection is necessary. After usage the solution should be disposed of in small quantities (small quantities less than 2 or 3 gallons at a time).</p> <ul style="list-style-type: none"> d. Mix as follows: <ul style="list-style-type: none"> (1) 12 oz volume (1-1/2 cups) of Ammonium Persulfate (6810-234-8360). (2) 12 oz volume (1-1/2 cups) of Ammonium Carbonate (6810-234-8358). (3) 48 oz volume of water. (4) Add Ammonium Hydroxide, 6810-243-4436, to make 1 gallon of solution. (5) Mix solution as indicated above, to minimize exposure to fumes. <p style="text-align: center;">CAUTION</p> <p>Do not seal container for approximately 10-15 minutes after initial mixing as there is a slight build up of pressure. Also this solution is very corrosive when allowed to dry on a metal surface or if it makes contact with a hot surface of a barrel. Care should be taken to make certain it does not come in contact with blued metal, gun actions or aluminum receivers.</p>

Table 3-1. Guide to Maintenance Functions—Continued

Item	Removal/ installation	Disassembly/ assembly	Cleaning and lubrication	Repair
Upper receiver group—Cont				<p>e. Pour the mixed solution into the barrel until the level is above the end of the muzzle. This level must be maintained and should be checked frequently. Keep barrel in an up-right position for approximately 30 minutes, pour out solution and check color. If color is deep blue repeat process until solution shows only a slight trace of blue. Then wash out barrel with hot water, clean the bore with bore brush and dry with small arms cleaning swabs. Lubricate immediately.</p>
Bolt carrier group	Refer to TM 9-1005-249-20	Refer to TM 9-1005-249-20 and figure 3-5	Refer to TM 9-1005-249-20 and table 3-2	Refer to section III.
Lower receiver group	Refer to TM 9-1005-249-20	Refer to figure 3-6 and 3-7	Refer to TM 9-1005-249-20 and table 3-2	<p>1. Refer to section III.</p>
				<p style="text-align: center;">NOTE</p> <p>Weapons with frozen pivot pin, detents, and springs, will be repaired as follows:</p> <p>a. Drill a 1/16 inch hole into the spring cavity on the right side of lower receiver, as indicated in figure 3-8.</p> <p>b. Place the forward portion of lower receiver in a container of RBC, rifle bore cleaning compound or P-C-111, carbon removing compound and allow to soak for a period of 24 hours.</p> <p>c. Remove the pivot pin, detent and spring using a small piece of wire.</p> <p>d. After removal of parts the recesses and all parts must be thoroughly cleaned and lubricated with LSA, lubricating oil, semi-fluid, before assembly.</p> <p>e. Lower receivers and extensions that are corroded as shown in figures 3-16, 3-17 and 3-18, should be repaired same as upper receiver group. Receiver and extension indicating loss of protective coating should be sprayed or painted with solid film lubricant to prevent corrosion.</p> <p>2. Stock assemblies that contain gouges, dents, punctures and crushed areas (fig 3-9) can be repaired as shown in TM 9-1005-301-30.</p> <p>3. Stock assemblies damaged as indicated in figure 3-9 will be replaced.</p>
Rifle bipod	Refer to TM 9-1005-249-20	Not authorized	Refer to table 3-2	Remove rust, touch up and lubricate.

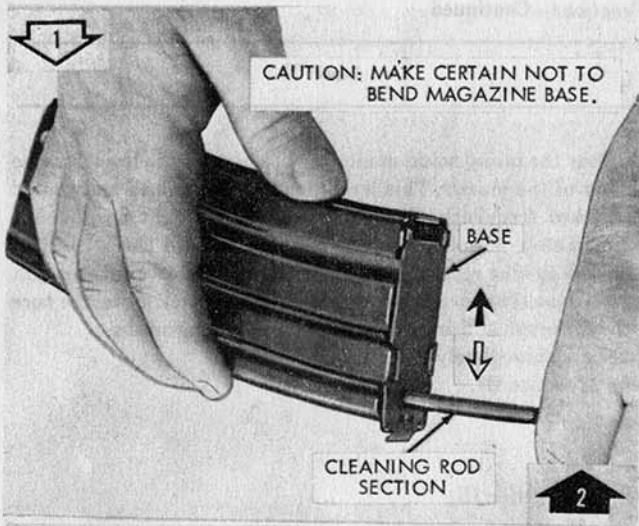

Remove/Install magazine base.

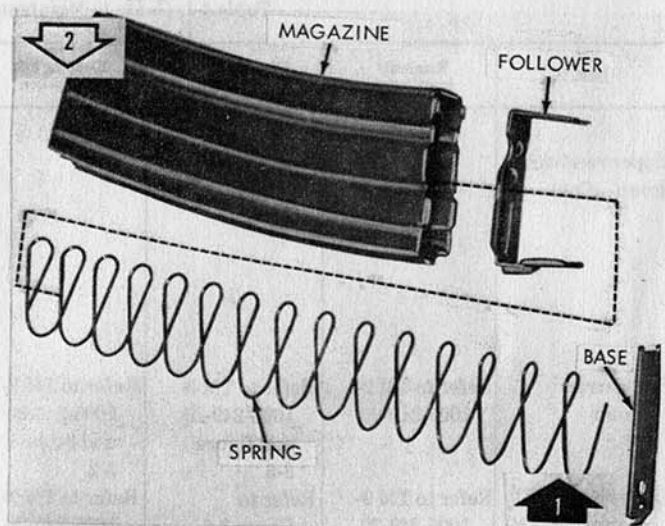

Remove/Install magazine spring and follower.

WE 68917

Figure 3-1. Disassembly/assembly of magazine assembly.

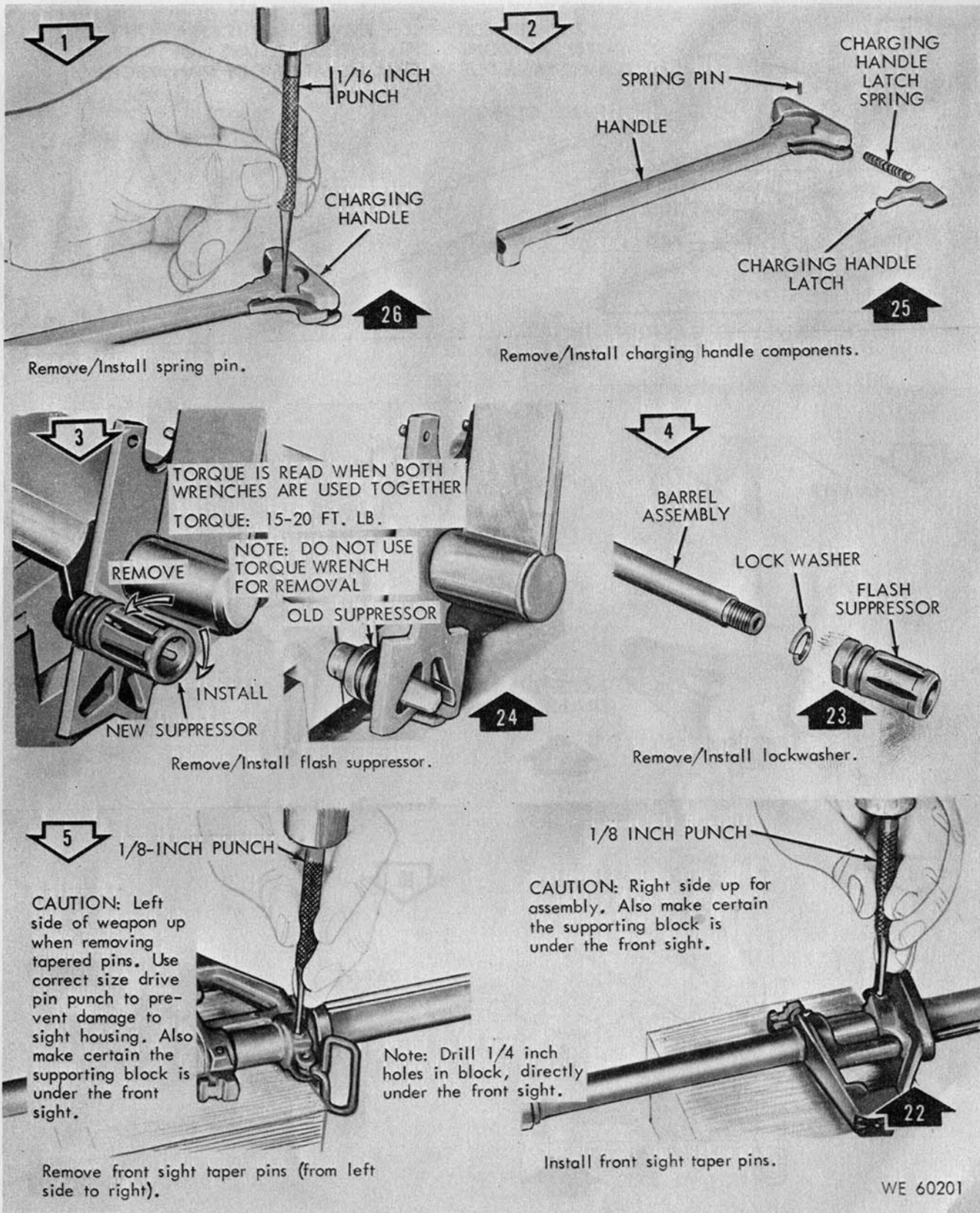

WE 60201

Figure 3-2. Disassembly/assembly of upper receiver group (1 of 6)

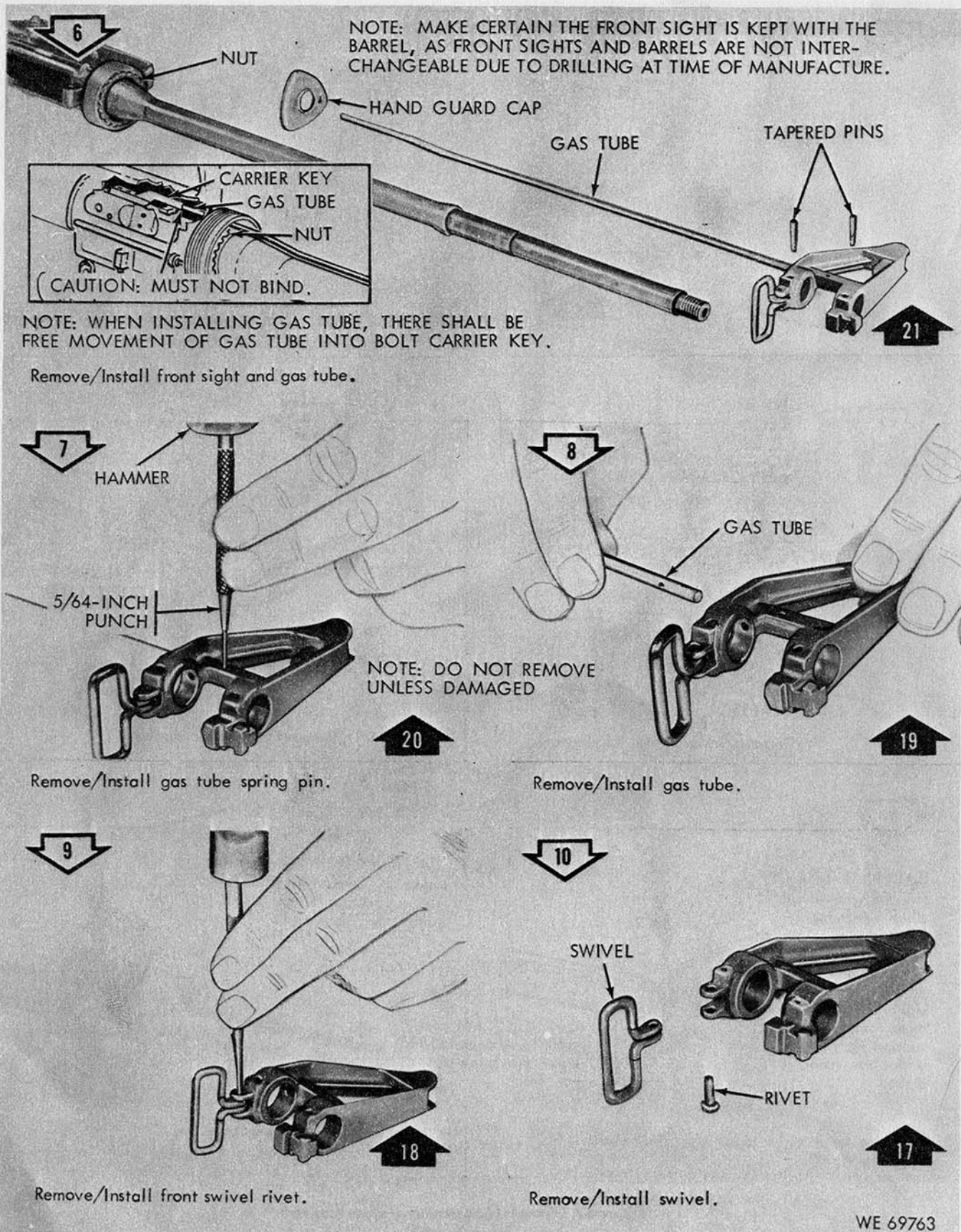
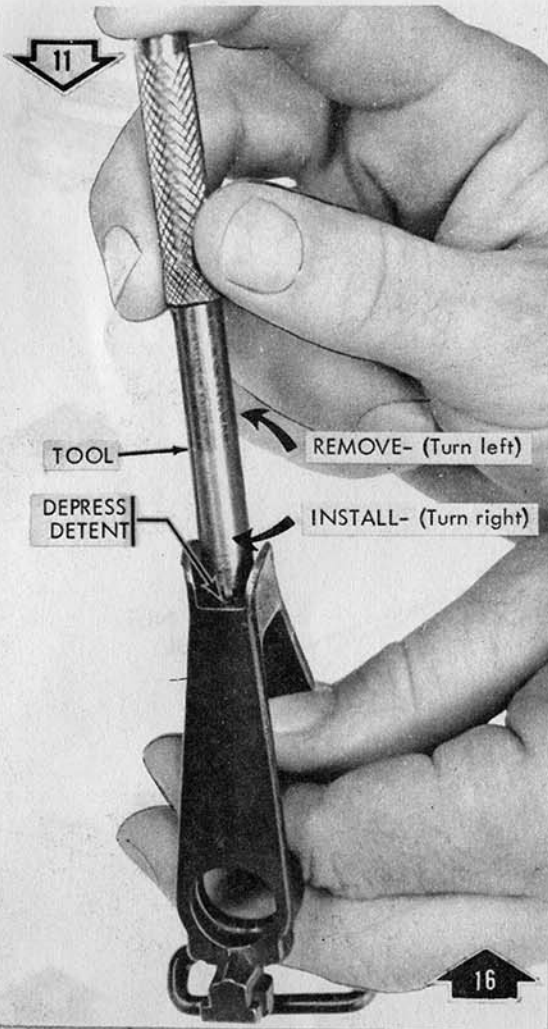
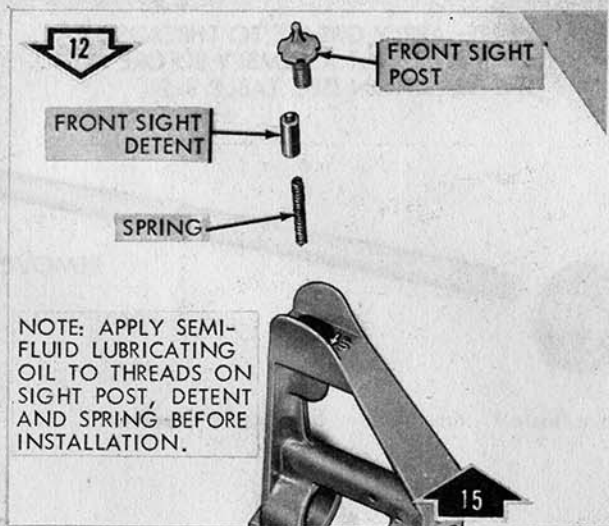

Figure 3-2. Disassembly/assembly of upper receiver group. (2 of 6)



Remove/Install front sight post



Remove/Install front sight detent and front sight spring.

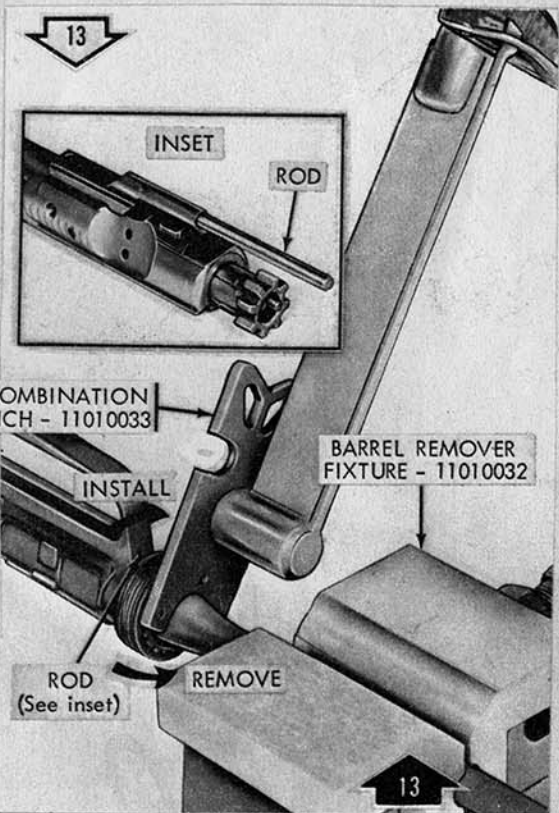

Remove/Install barrel nut assembly.

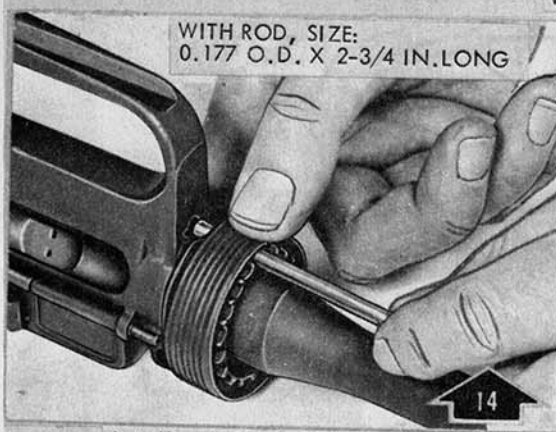

Install and align barrel nut assembly

TORQUE IS READ WHEN BOTH WRENCHES ARE USED TOGETHER.
TORQUE: 30 FT. LB. THEN TIGHTEN TO ALINE ROD THROUGH NUT.

NOTE: DO NOT USE TORQUE WRENCH FOR REMOVAL. ALSO MAKE CERTAIN ALL THREE DRIVE PINS OF WRENCH ARE ENGAGED WITH BARREL NUT.

WE 69764

Figure 3-2. Disassembly/assembly of upper receiver group. (3 of 6)

14

NOTE: APPLY GREASE TO THREADS OF BARREL NUT ASSEMBLY BEFORE INSTALLATION (SEE TABLE 3-2).

BARREL ALINEMENT PIN

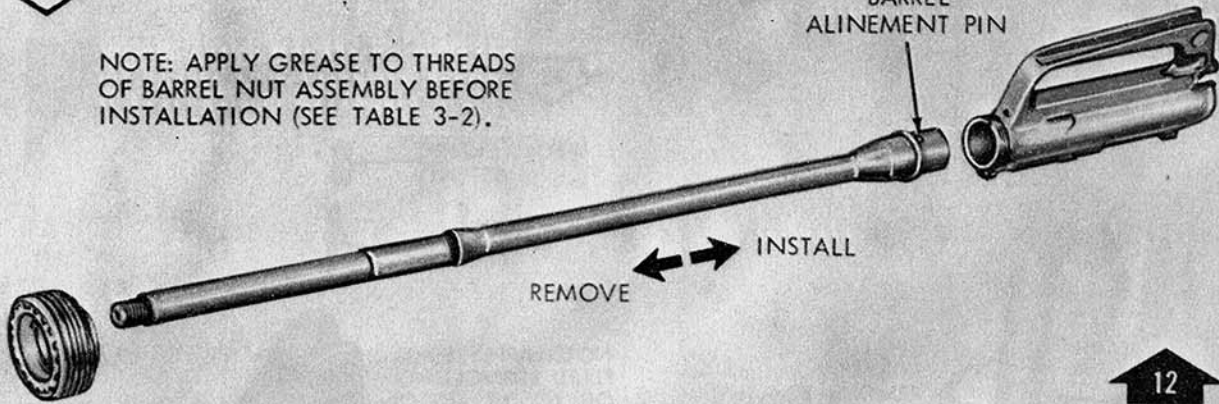

12

Remove/Install barrel assembly from/to receiver.

15

BARREL NUT ASSEMBLY

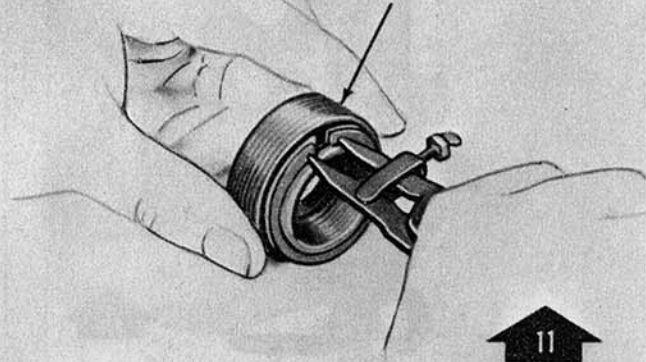

11

Remove/Install retaining ring.

16

BARREL NUT

HAND GUARD SLIP RING

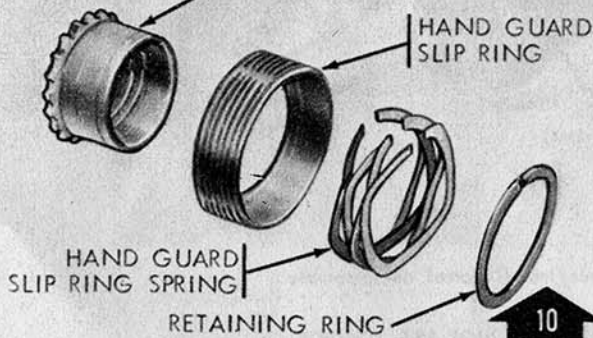

10

Disassemble/Assemble barrel nut assembly.

17

RETAINING RING

SPRING

PIN

COVER

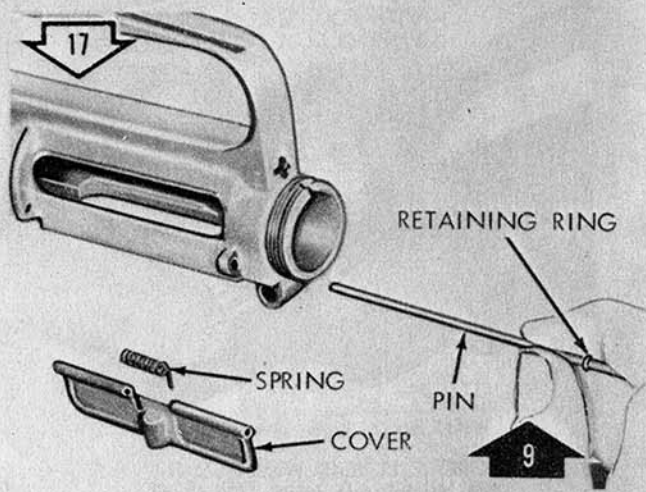

9

Remove/Install ejection port cover pin, ejection port cover spring and ejection port cover.

WE 13631B

Figure 3-2. Disassembly/assembly of upper receiver group. (4 of 6)

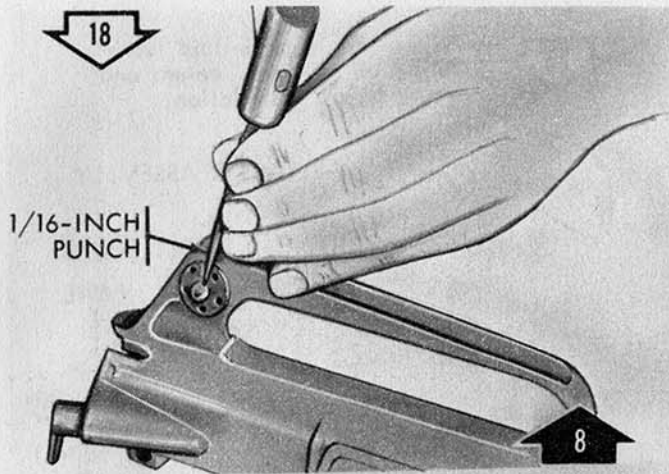

18
1/16-INCH PUNCH
8
Remove/Install rear sight windage drum spring pin.

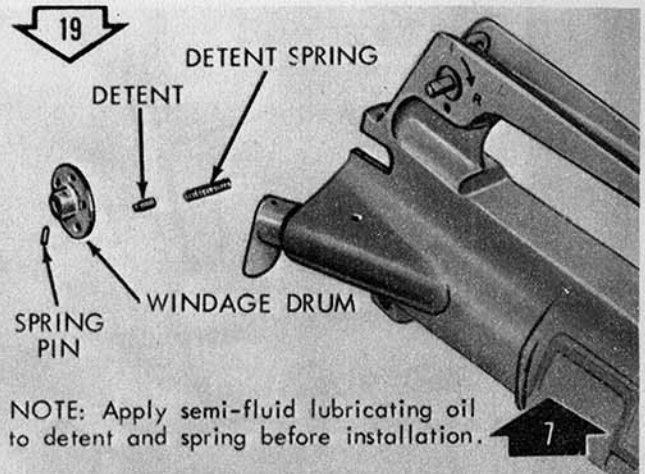

19
DETENT SPRING
DETENT
WINDAGE DRUM
SPRING PIN
7
NOTE: Apply semi-fluid lubricating oil to detent and spring before installation.
Remove/Install rear sight windage drum, rear sight detent and rear sight detent spring.

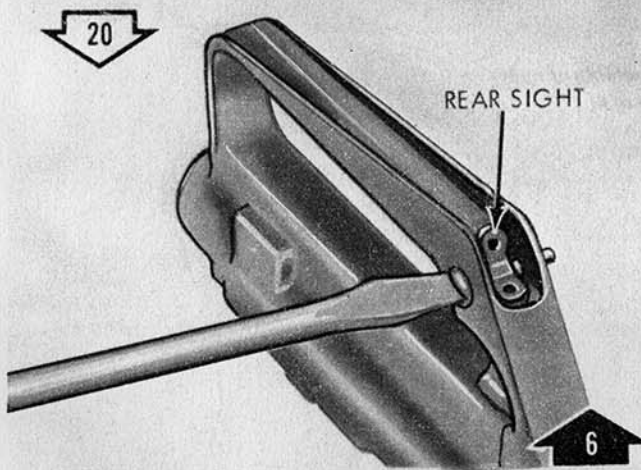

20
REAR SIGHT
6
Remove/Install rear sight windage screw.

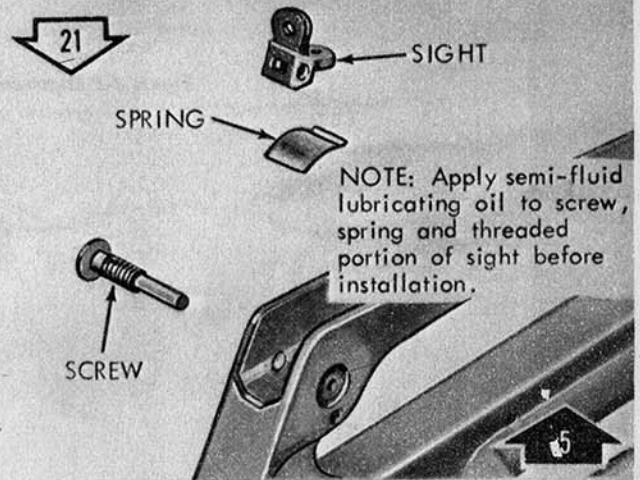

21
SIGHT
SPRING
SCREW
5
NOTE: Apply semi-fluid lubricating oil to screw, spring and threaded portion of sight before installation.
Remove/Install rear sight and rear sight spring.

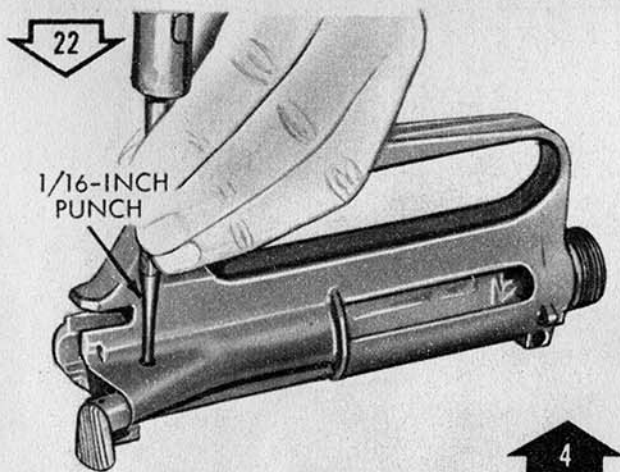

22
1/16-INCH PUNCH
4
Remove/Install spring pin.

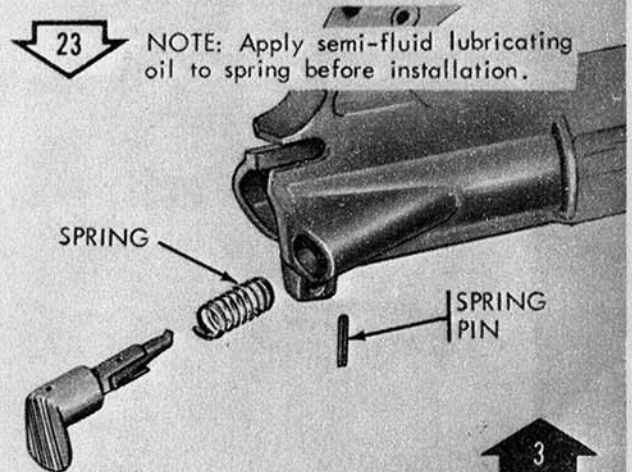

23
3
NOTE: Apply semi-fluid lubricating oil to spring before installation.
Remove/Install forward assist assembly.

WE 13632B

Figure 3-2. Disassembly/assembly of upper receiver group. (5 of 6)

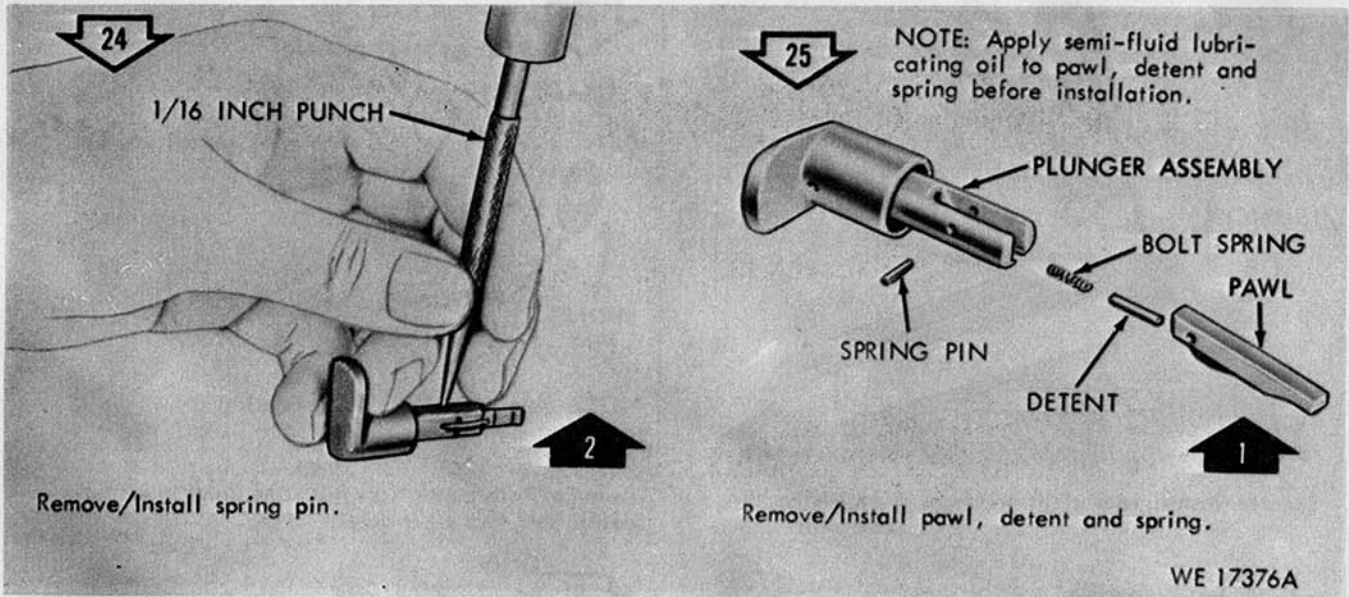

Figure 3-2. Disassembly/assembly of upper receiver group. (6 of 6)

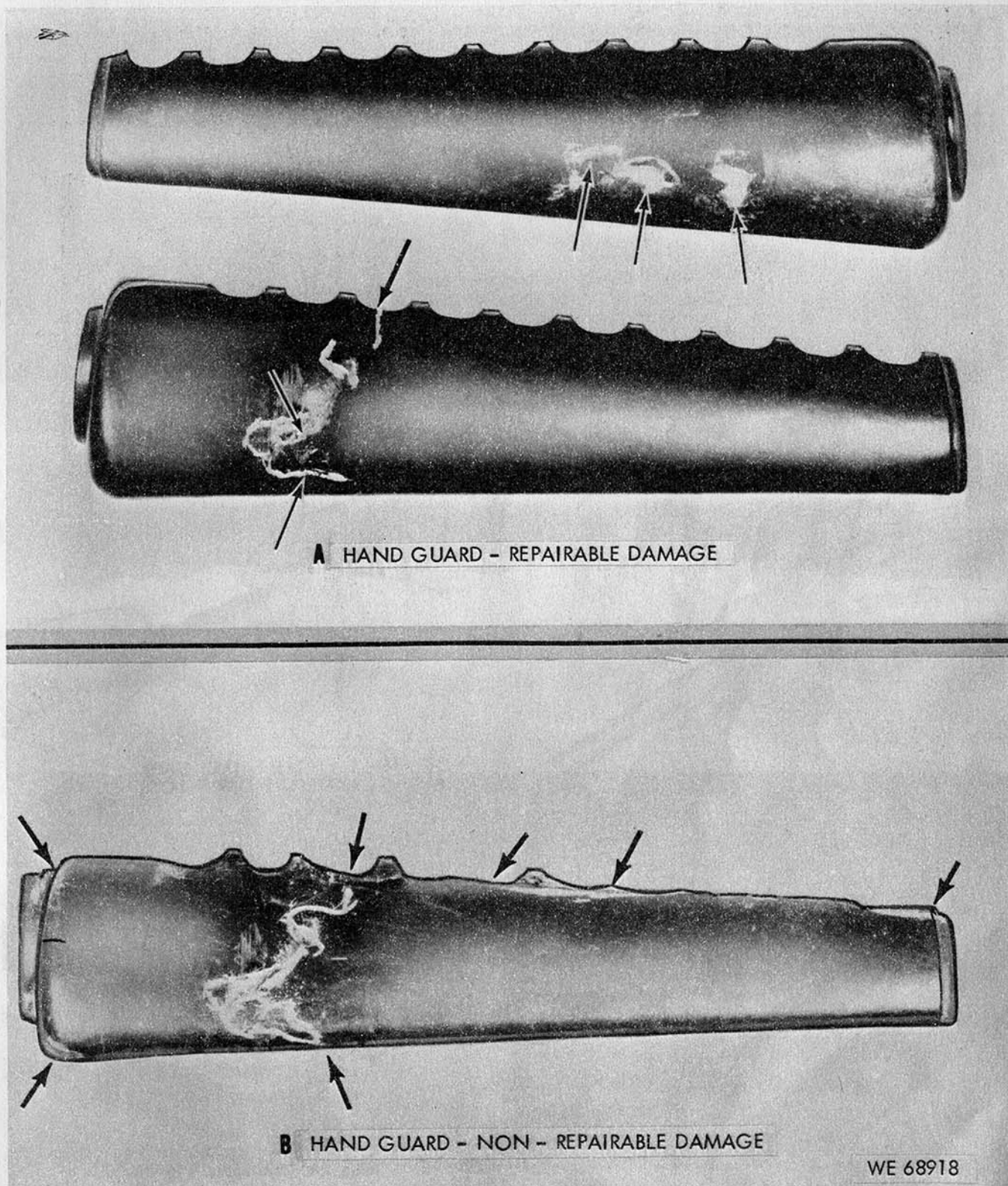

Figure 3-3. Repairable/non-repairable hand guards.

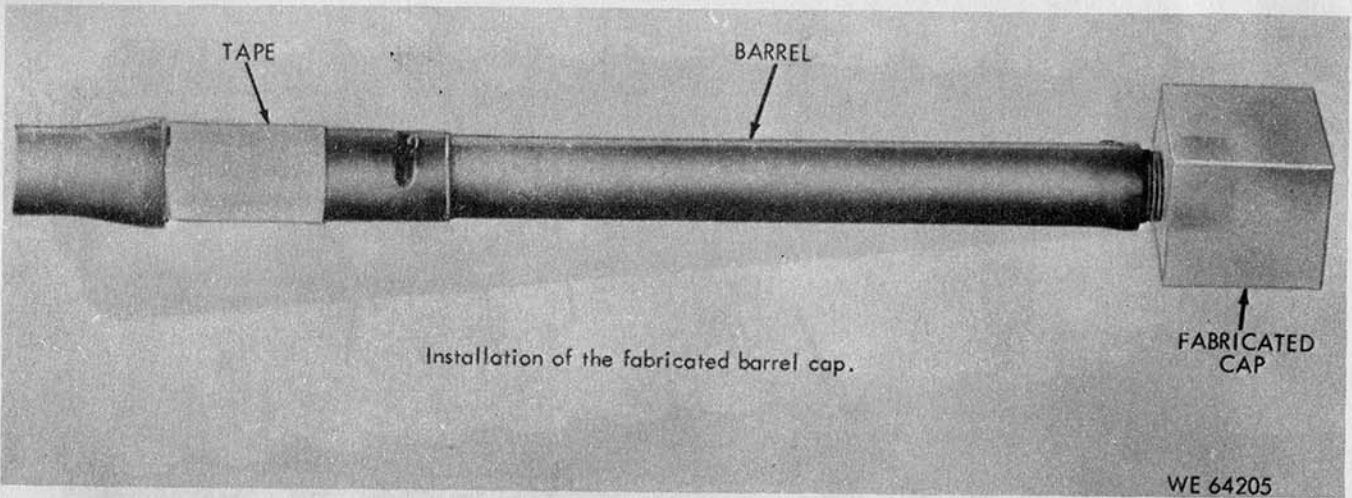
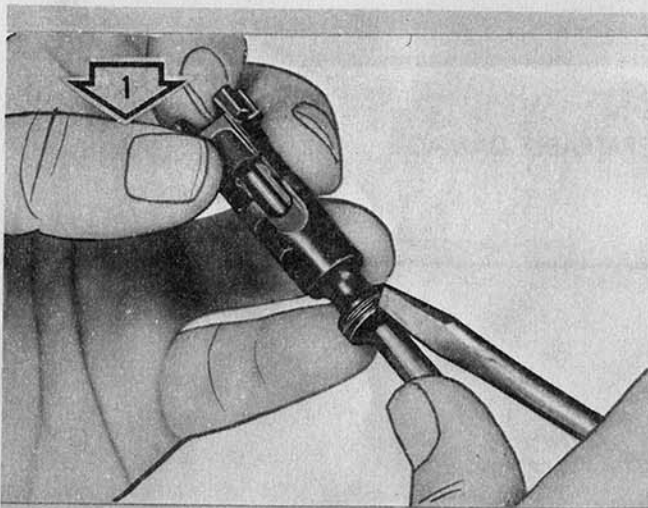
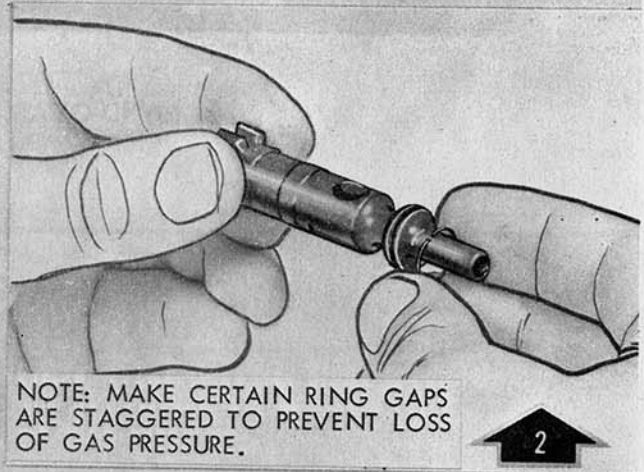

Figure 3-4. Gas port covered and fabricated barrel cap installed.



Remove bolt rings.



NOTE: MAKE CERTAIN RING GAPS ARE STAGGERED TO PREVENT LOSS OF GAS PRESSURE.

Install bolt rings.

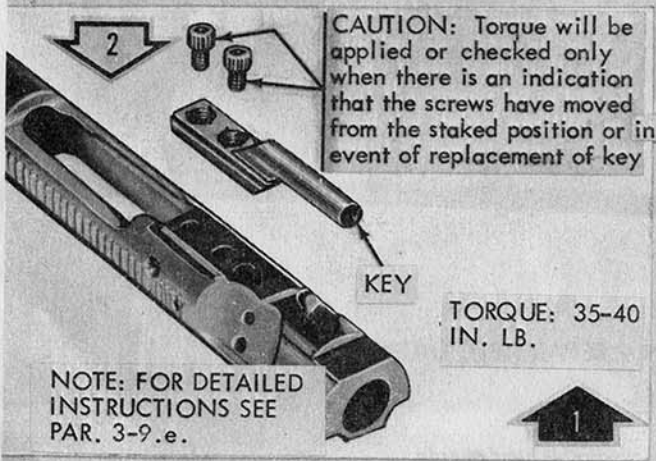

NOTE: FOR DETAILED INSTRUCTIONS SEE PAR. 3-9.e.

TORQUE: 35-40 IN. LB.

Remove/Install bolt carrier key.



NOTE: AFTER TORQUING, SCREWS WILL BE STAKED AS SHOWN TO INSURE POSITIVE RETENTION.

CAUTION: Make certain the bolt carrier is level and positioned with the flat surface directly under the screws, when staking, to prevent bending the bolt carrier.

Screws installed and staked.

WE 60195

Figure 3-5. Disassembly/assembly of bolt carrier group.

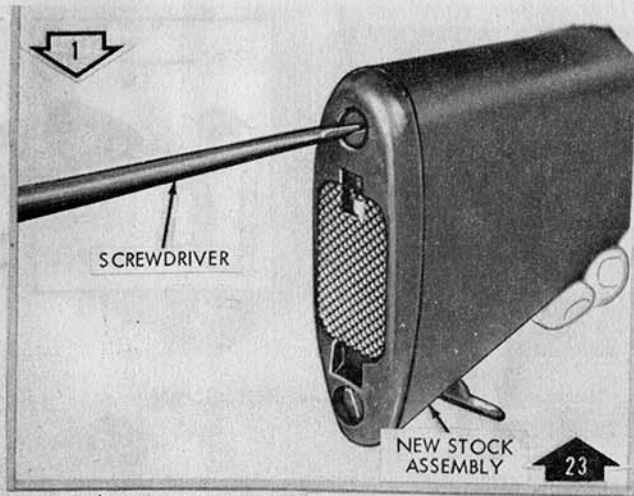

Remove/Install butt cap screw



Remove/Install stock assembly

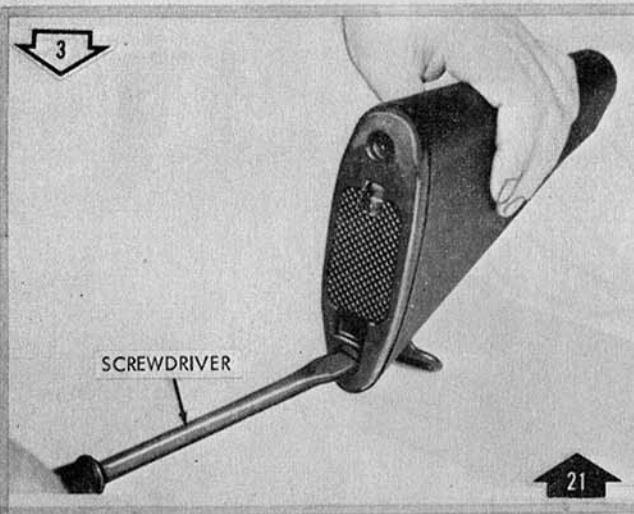

Remove/Install machine screw

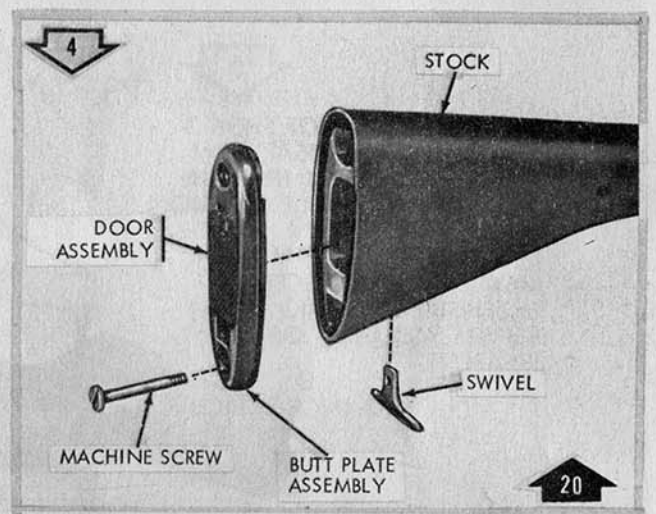

Remove/Install sling swivel, butt plate assembly and door assembly.

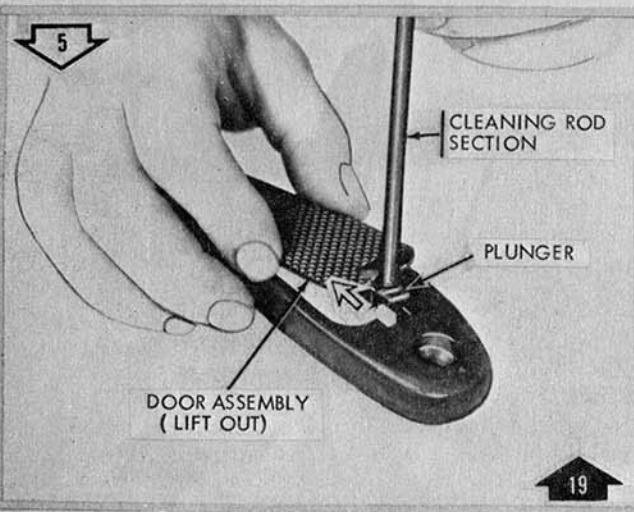

Unlock/Lock plunger and Remove/Install door assembly

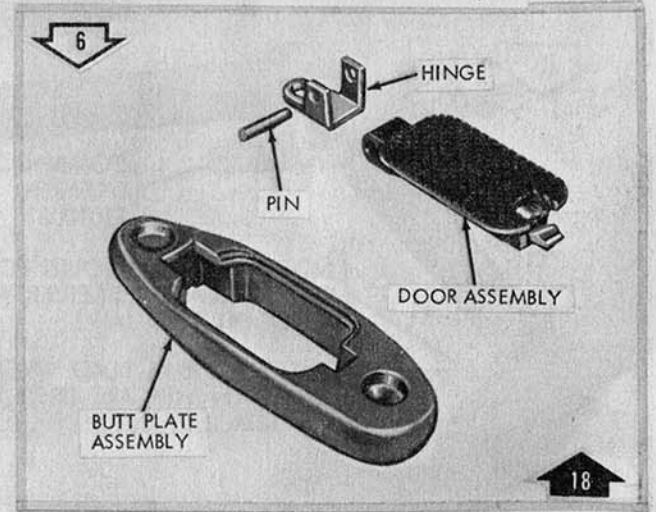

Remove/Install pivot latch pin and hinge.

WE 68919

Figure 3-6. Disassembly/assembly of lower receiver group. (1 of 5)

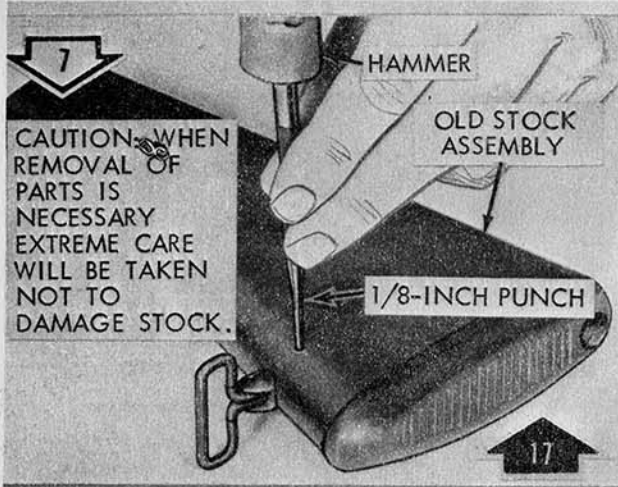

Remove/Install rear swivel spring pin.

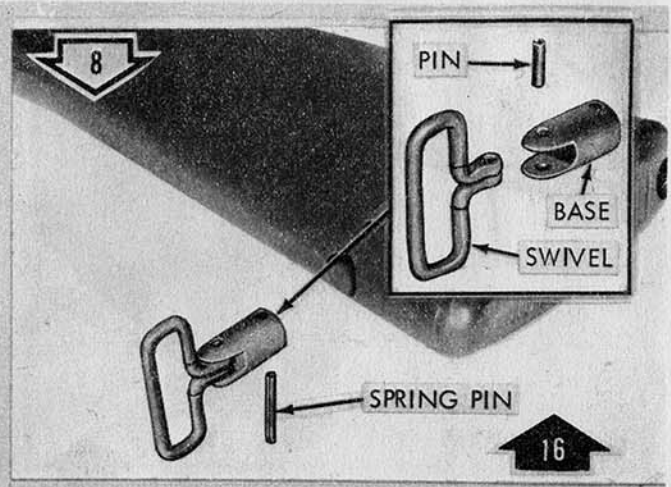

Remove/Install spring pin, gun sling swivel and base.

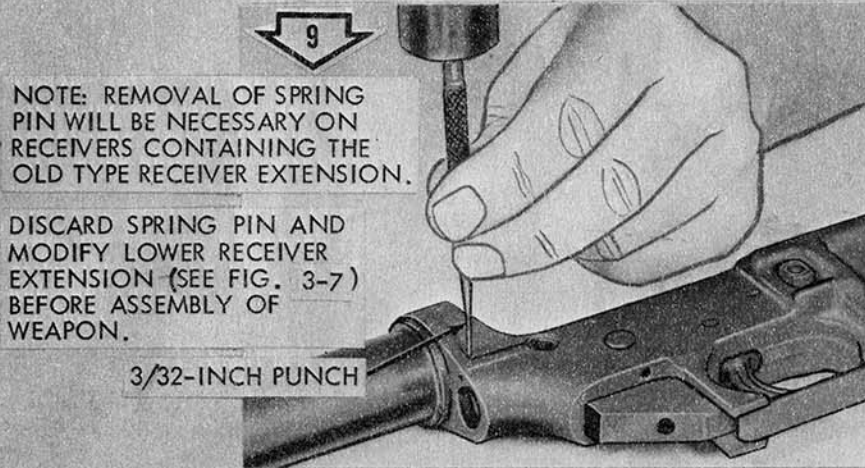

Remove lower receiver extension spring pin.

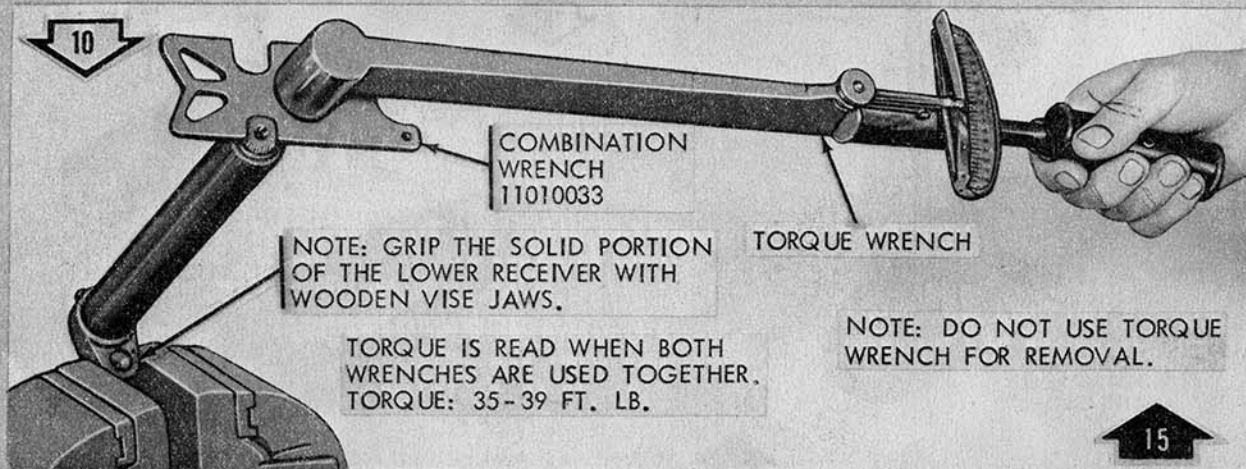

Loosen/Tighten lower receiver extension.

WE 69285

Figure 3-6. Disassembly/assembly of lower receiver group. (2 of 5)

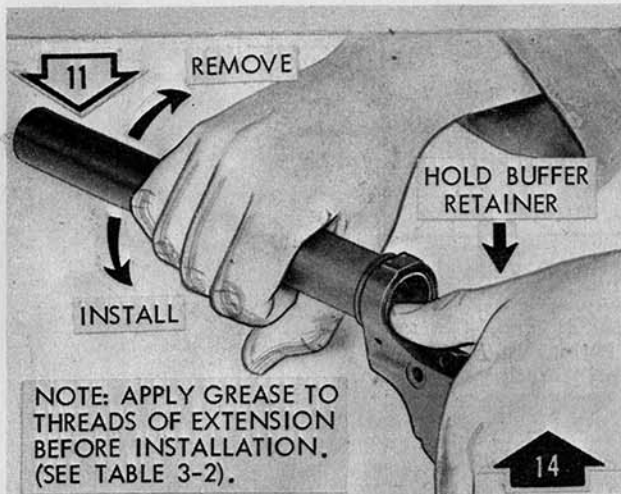

Remove/Install lower receiver extension from/to receiver.

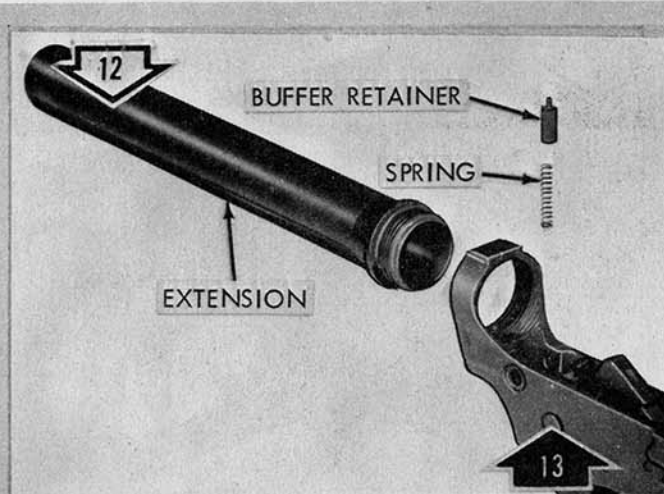

Remove/Install buffer retainer and buffer retainer spring from/to receiver.



Remove/Install hammer pin.

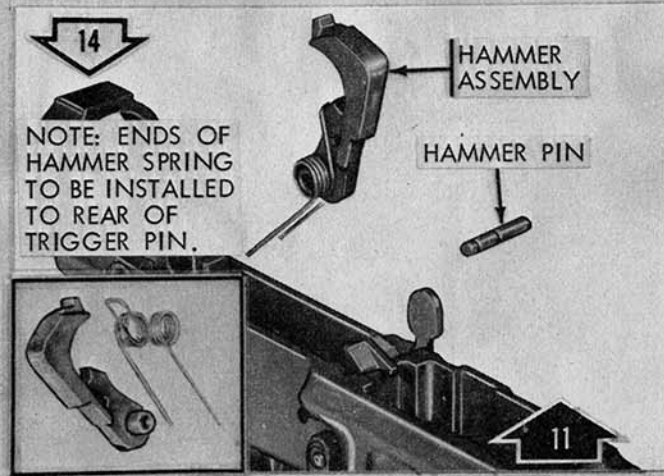

Remove/Install hammer assembly and hammer spring.

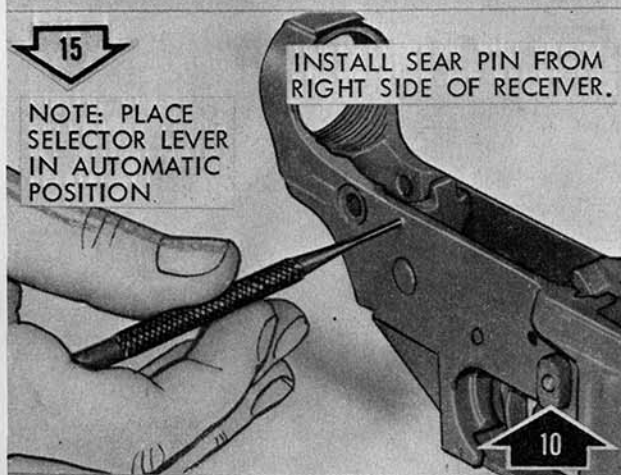

Remove/Install automatic sear pin.

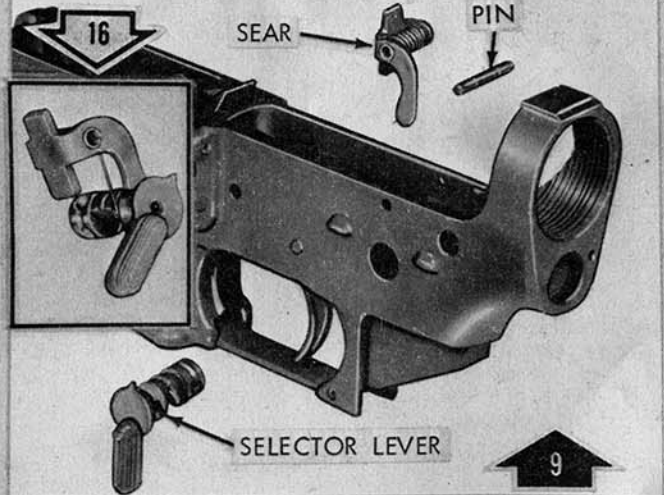

Remove/Install sear, pin and selector lever.

WE 69299

Figure 3-6. Disassembly/assembly of lower receiver group. (3 of 5)

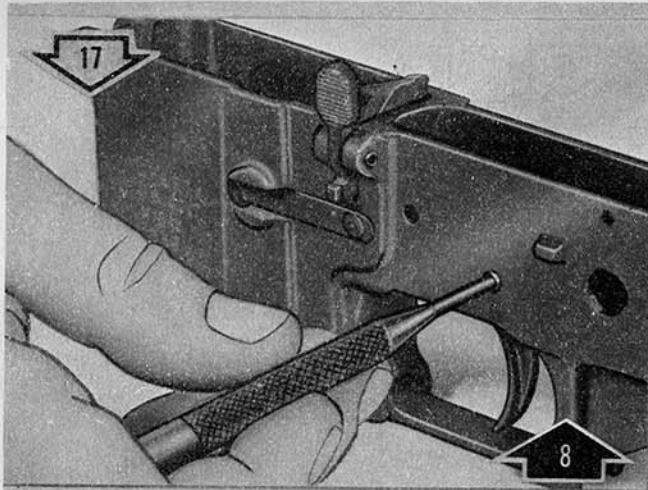

Remove/Install trigger pin.

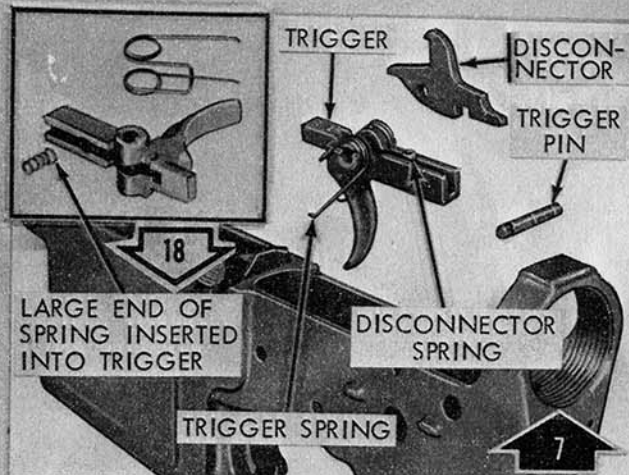

Remove/Install trigger, trigger spring, disconnecter, and disconnecter spring.

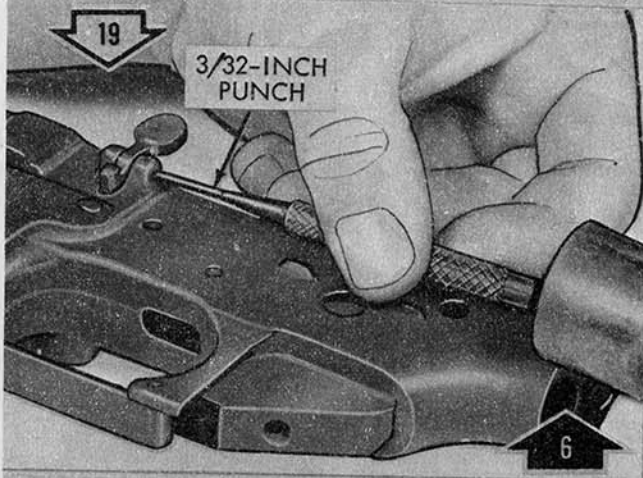

Remove/Install bolt catch spring pin.

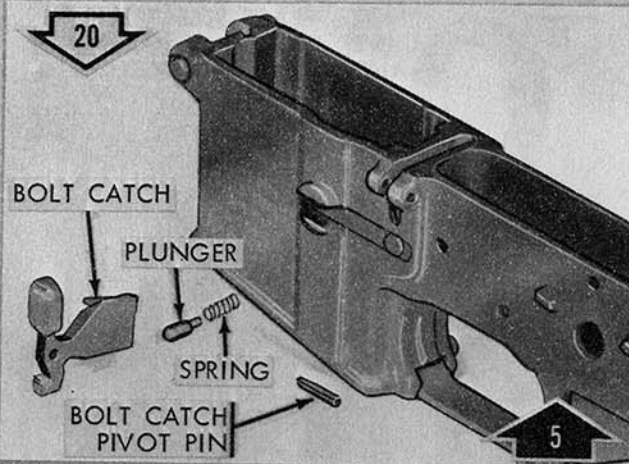

Remove/Install bolt catch, bolt catch plunger, and bolt catch spring.

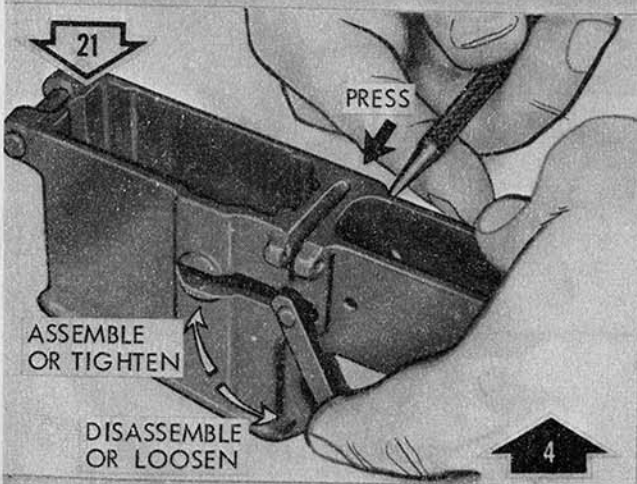

Remove/Install magazine catch.

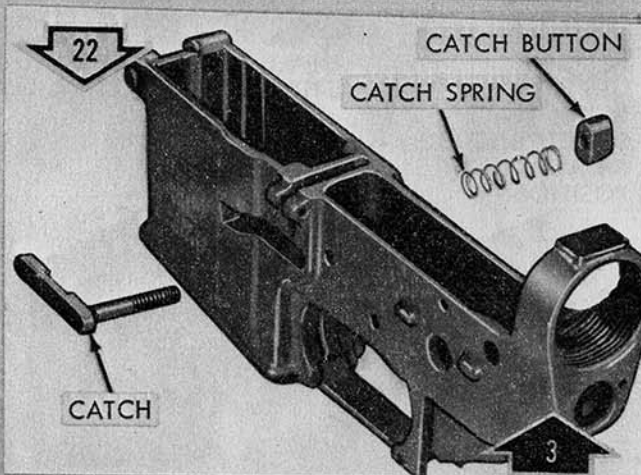

Remove/Install magazine catch button, and magazine catch spring.

WE 69301

Figure 3-6. Disassembly/assembly of lower receiver group. (4 of 5)

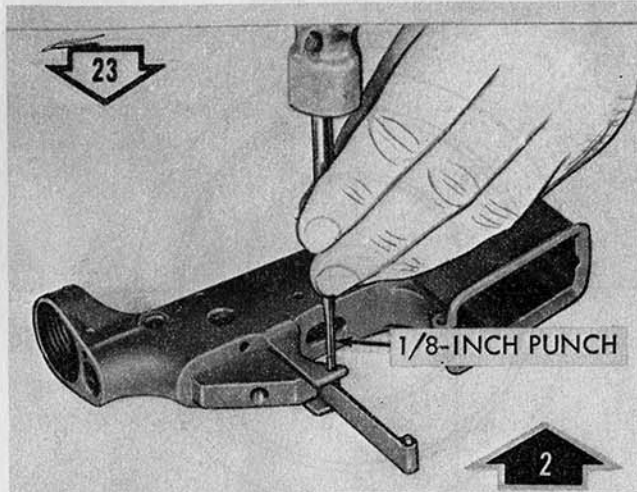

Remove/Install trigger guard spring pin.

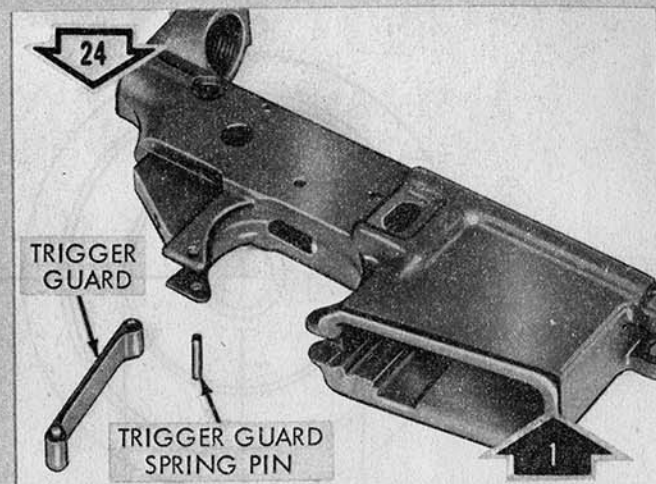

Remove/Install trigger guard.

WE 69300

Figure 3-6. Disassembly/assembly of lower receiver group. (5 of 5)

RECEIVER EXTENSIONS USABLE AFTER FORMING OF FLATS

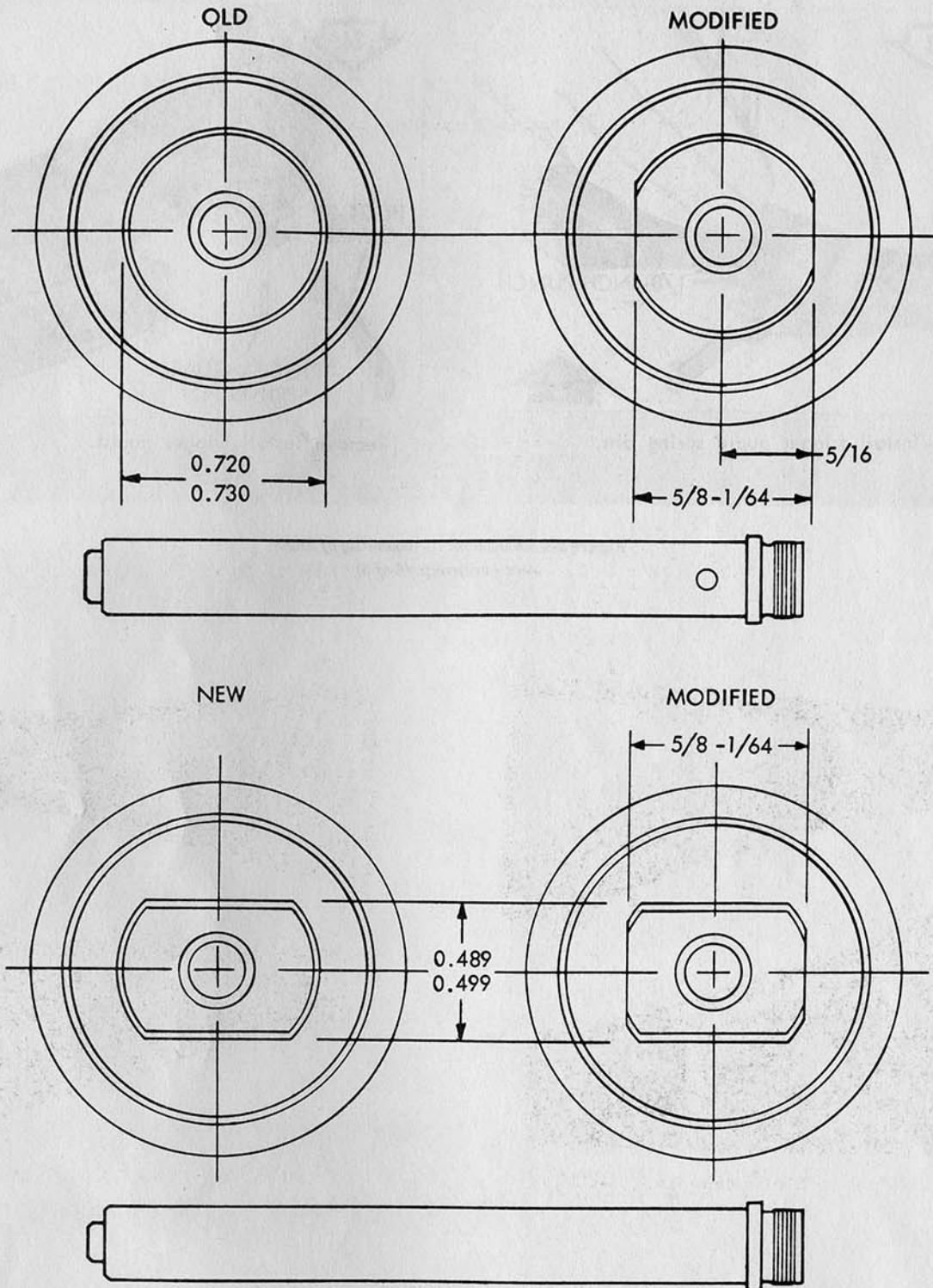

- 1 - The 5/8 inch flats can be formed by utilizing a "smooth cut" hand file with a safety edge. A milling machine can also be used.
- 2 - Use jet black touch up enamel or lacquer to cover machined area.



WE 16988A

Figure 3-7. Procedure for re-working old and new receiver extensions.

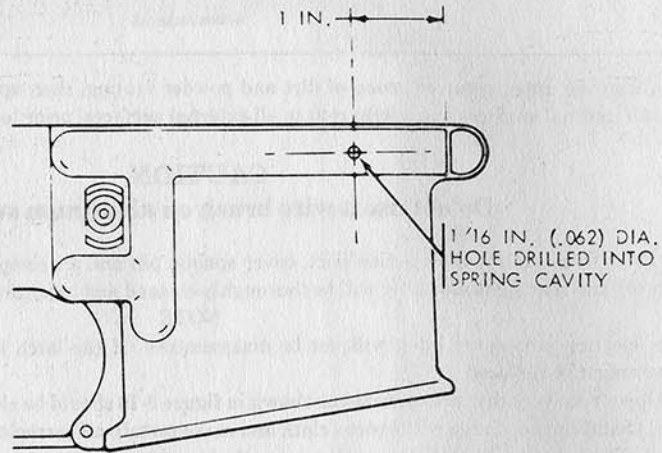

CAUTION: EXERCISE EXTREME CARE WHEN DRILLING HOLE THAT PENETRATION IS NOT MADE IN INNER WALL OF SPRING CAVITY. (SEE TABLE 3-1). WE 60203A

Figure 3-8. Location of hole for drilling into spring cavity.

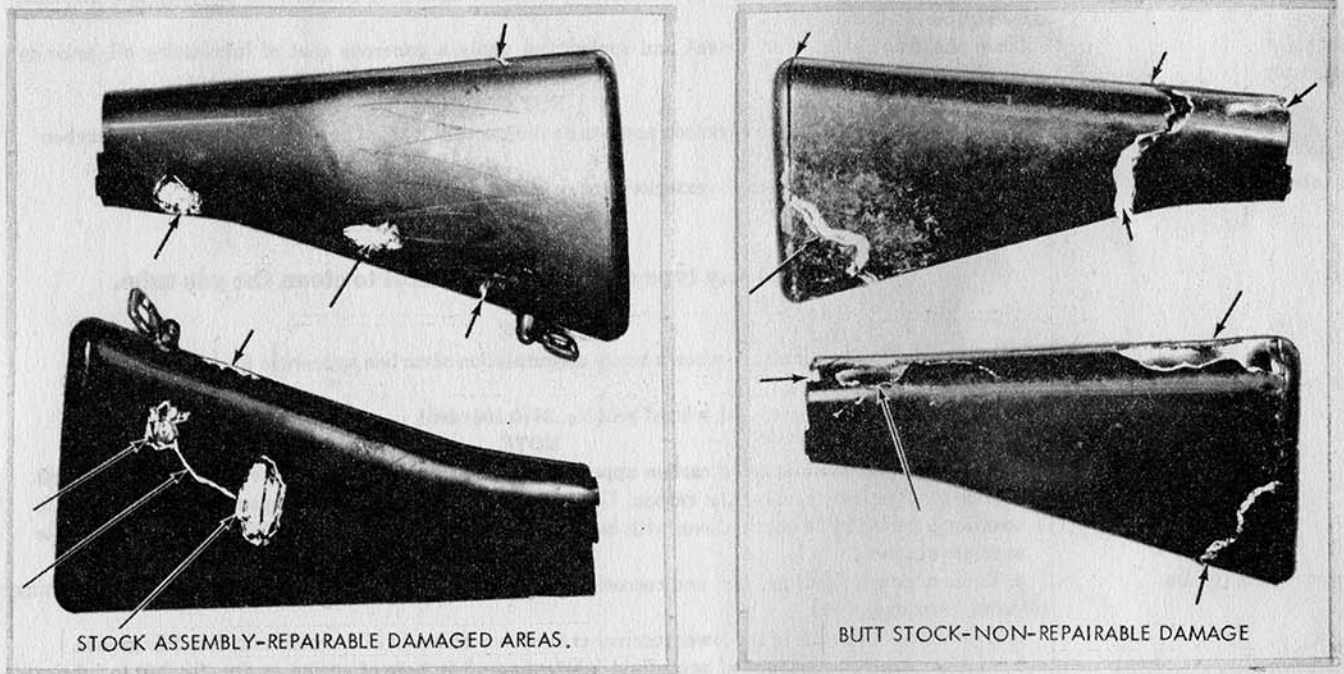

WE 68920

Figure 3-9. Repairable/non-repairable stock assemblies.

Table 3-2. Cleaning and Lubrication

Item	Action required
Upper receiver group	<p>a. Clean the upper receiver group of dirt and powder fouling, then apply a generous coat of lubricating oil to all internal surfaces and a light coat to all external surfaces, prior to assembly.</p> <p style="text-align: center;">CAUTION Do not use a wire brush on aluminum surfaces.</p> <p>b. Prior to assembly, the ejection port, cover spring, pin and all component parts of the forward assist assembly and rear sight assembly will be thoroughly cleaned and lubricated.</p> <p style="text-align: center;">NOTE</p> <p>The ejection port cover latch will not be disassembled. If the latch is inoperative, the ejection port cover must be replaced.</p> <p>c. Upper receivers that are corroded as shown in figure 3-10 should be cleaned as follows:</p> <p>(1) Sand corroded area with crocus cloth and make certain all corrosion has been removed.</p> <p>(2) Wash area with dichloromethane (methylenechloride) to remove all dirt, grease and/or foreign material. Repair as indicated in table 3-1.</p>
Barrel	<p>Remove carbon deposits and dirt from the barrel bore, chamber and barrel extension (locking lug area). If hard carbon is still evident in the chamber, it can be removed by using an electric drill, with a cleaning rod section, chamber brush, and rifle bore cleaning compound. Then attach a small piece of crocus cloth to polish the chamber after cleaning. Dry thoroughly with swabs.</p>
Barrel nut assembly	<p>a. Remove all evidence of dirt and rust.</p> <p>b. Prior to assembly, apply a coating of semi-fluid lubricating oil to components of the barrel nut assembly with exception of the threads of the barrel nut. These should be coated with molybdenum disulfide grease (9150-754-2595).</p>
Front sight assembly	<p>Clean the front sight post, detent and spring and apply a generous coat of lubricating oil, prior to assembly.</p> <p style="text-align: center;">NOTE</p> <p>When a heavy accumulation of carbon appears on the gas tube it must be cleaned using P-C-111, carbon removing compound.</p>
Gas tube	<p>Remove carbon deposits from the exterior surface of the tube.</p> <p style="text-align: center;">CAUTION Do not use any type of abrasive material to clean the gas tube.</p> <p style="text-align: center;">NOTE</p> <p>Replace gas tube when a heavy accumulation of carbon appears in the tube.</p>
Bolt carrier group	<p>a. Clean extractor recess.</p> <p>b. Clean the gas relief ports with a hand held No. 36 (0.106) drill.</p> <p style="text-align: center;">NOTE</p> <p>When a heavy accumulation of carbon appears in the bolt carrier key, remove carrier key from bolt carrier to effectively remove the carbon. Use P-C-111, carbon removing compound, and allow key to soak for a period of 24 hours. Clean with bore brush, inserting as far as possible, then turn clockwise to remove carbon.</p>
Lower receiver group	<p>a. Remove powder fouling, dirt and corrosion. Prior to assembly, apply a generous coat of lubricating oil to all functional parts.</p> <p>b. Lubricate the threads of the lower receiver extension with a coat of molybdenum disulfide grease.</p> <p>c. Apply a generous amount of semi-fluid lubricating oil in hole of spring cavity (fig 3-8) to lubricate detent, spring, and pivot pin.</p> <p>d. Lower receivers and extensions that are corroded as shown in figures 3-16, 3-17 and 3-18 should be cleaned same as upper receiver group.</p>
General	<p>Component parts such as flash suppressor, barrel bore and bolt carrier group, which contain a hard carbon residue, will require special cleaning, using P-C-111, carbon removing compound, as follows:</p> <p style="text-align: center;">WARNING</p> <p>Avoid skin contact. The compound should be washed off thoroughly with running water if it comes in contact with the skin. A good lanolin base cream, after exposure to compound, is helpful. The use of gloves and protective equipment is recommended.</p>

Table 3-2. Cleaning and Lubrication—Continued

Item	Action required
General—Cont.	<p>a. Using a suitable container, fill with fresh compound.</p> <p>b. Before soaking components in compound, remove all grease, dirt and oil using dry cleaning solvent. Place parts to be cleaned in container, making certain they are completely immersed.</p> <p>c. Soak for 24 hours. Remove parts and allow to drain. Rinse with dry cleaning solvent. To effectively remove carbon, brush with stiff bristle brush under running water.</p>

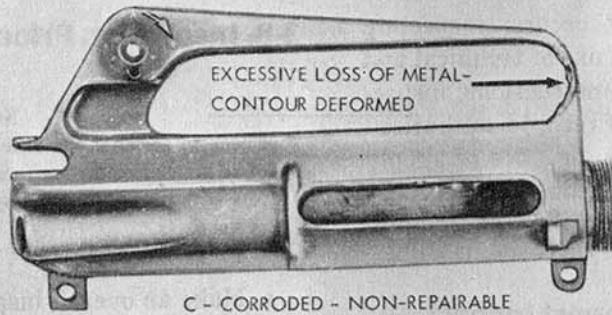
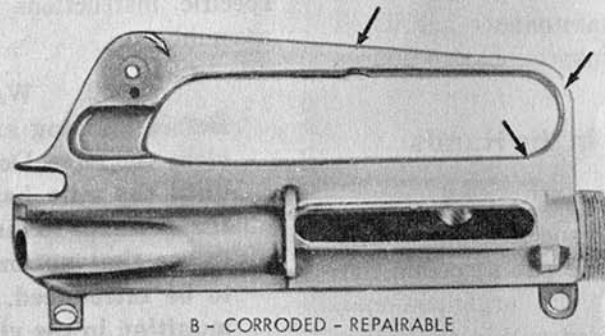
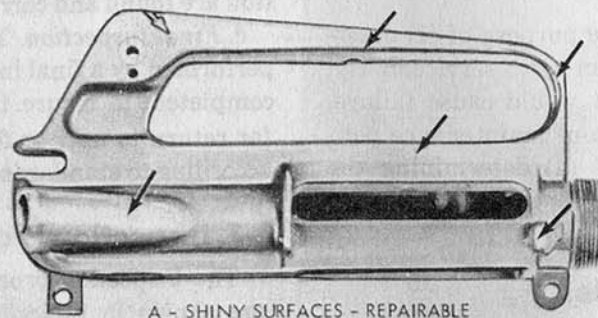

WE 64561

Figure 3-10. Repairable and non-repairable upper receivers—right side view.

Section II. MAINTENANCE INSPECTIONS

3-2. General

This section provides specific instructions for the inspection by maintenance personnel of materiel in the hands of troops in the field or in maintenance shops. Troubleshooting information is incorporated wherever applicable as a normal phase of inspection.

3-3. Purpose of Inspection

Inspections are made for the purpose of (1) determining the condition of an item as to serviceability, (2) recognizing conditions that would cause failure, (3) assuring proper application of maintenance policies at prescribed levels, and (4) determining the ability of a unit to accomplish its maintenance and supply missions.

3-4. Categories of Inspection

The two categories of inspection performed by direct and general support maintenance are listed in paragraphs 3-5 and 3-6. For inspections procedures refer to table 3-3.

3-5. Inspection of Materiel in the Hands of Troops in the Field

Spot-check inspection is an inspection performed on a percentage of materiel in order to ascertain the adequacy and effectiveness of organizational maintenance and supply. Included within the scope is the inspection of equipment to detect probable failures before unserviceability occurs; inspection to determine the availability and use of technical and supply manuals and lubrication instructions; inspection to determine the accuracy of records, authorized levels of equipment and supplies, practice of supply economy, preservation, and knowledge of the proper procedures for requisitioning supplies and equipment and follow-up thereon.

3-6. Direct and General Support Inspection

a. *Initial Inspection.* This is an inspection of materiel received in maintenance shops for purpose of determining the degree of repairs and parts requirements. This includes determination of modification work orders to be applied.

b. *In-Process Inspection.* These are inspections performed in the process of repairing the materiel, to insure that all parts conform to the prescribed repair standards, that the workmanship is in accordance with approval methods and procedures, and that deficiencies not disclosed by initial inspection are found and corrected.

c. *Final Inspection.* This is an acceptance inspection performed by a final inspector after repairs have been completed, to insure that the materiel is acceptable for return to user or for return to replacement stock according to standards established.

3-7. Inspection Procedures

The inspection procedures for the rifles and bipod are shown in table 3-3. Refer to paragraph 3-8 for specific instructions on inspection prior to disassembly.

WARNING

Before starting an inspection, be sure to clear the rifle. Do not actuate the trigger until the rifle has been cleared. Inspect the chamber to insure that it is empty and to see that no ammunition is in position to be introduced. Avoid having live ammunition in the vicinity of the work area.

3-8. Inspection Prior to Disassembly

NOTE

Check to see that the rifle and bipod have been cleaned of all grease, oil, dirt, or foreign matter which might interfere with proper functioning or obscure the true condition of the parts.

a. Make an overall inspection of the rifle and bipod for general appearance, condition, and operation.

b. On materiel turned in for repair, make an initial inspection to determine the extent of repair required and the basis of procuring the parts or assemblies necessary to accomplish the repair.

c. Refer to chapter 5 for final inspection.

Table 3-3. Maintenance Inspections

Inspection of material in the hands of troops	Direct and general support inspections		Action	Reference
	Spot-Check	Initial		
X	X		1. MAGAZINE ASSEMBLY	
X	X		a. Visually inspect tube for bulges, dents, cracks or damaged feeder lips.	
X	X		b. Check the rear area of follower for chips or excessive wear which would impair the functioning of the bolt catch.	
X	X		c. Examine spring for breaks, rust, or improper assembly to the follower.	
X			2. UPPER RECEIVER GROUP	
X	X	X	a. <i>General</i>	
X	X	X	(1) Inspect for cracks, corrosion or mutilation. Small dents or gouges that do not affect functioning will not be cause for rejection. If receiver contains cracks or holes it will be replaced. For receivers, rejected due to corrosion, refer to figure 3-10.	
X	X		(2) Inspect all parts for wear and damage.	
X	X	X	(3) Check springs for breaks, deformation, and rust.	
X	X		b. <i>Hand Guard</i>	
X	X		(1) Inspect for breaks and separations of material which prevent proper retention or interfere with functioning of the weapon.	
X	X		(2) Inspect hand guards for broken vent tabs. If four tabs are missing from either hand guard, or two adjacent tabs are missing, replace hand guard. Hand guards which have opposing tabs missing should be interchanged.	
X	X		(3) Cracks in hand guard in other than critical areas not exceeding three inches in length with a width of not more than 1/16 and also dents, gouges, or crushed areas can be repaired as indicated in table 3-1.	Fig 3-11.
X	X		c. <i>Barrel and Barrel Extension</i>	
X	X		(1) Inspect surfaces for cracks and defects.	
X	X		(2) Check barrel extension for burs, broken and worn locking lugs.	
X	X		(3) Bore must be clean and free of rust.	
X	X		(4) Pits in bore, no wider than a land or groove and 3/8 inch or less in length, are allowable.	
X	X		(5) Uniformly fine pits or fine pits in bore in a densely pitted area are allowable.	
X	X		(6) Lands that appear dark due to coating of gliding metal from projectiles are allowable.	
X	X		(7) Definitely ringed bores or bores ringed sufficiently to bulge the outside surface of the barrel are cause for rejection.	
X	X		(8) Inspect for barrel erosion, using barrel erosion gage 7799792.	Fig 3-12.
			NOTE	
			Stripping of lands and grooves shall not be cause for rejection unless so determined by barrel erosion gage.	
X	X		(9) Chamber must be clean and free of carbon deposits or rust.	Table 3-2.
X	X		(10) Inspect chamber using the chamber reflector tool, 8448201. Position tool in chamber and slowly rotate upper receiver group to enable reflected light to illuminate the chamber. A flash light will improve the reflective qualities of the tool. Uniformly fine pits or fine pits in a densely pitted area are allowable. Pits 1/8 inch in length and pits large enough to extend from the body of the chamber into the shoulder stop	Fig 3-13.

Table 3-3. Maintenance Inspections—Continued

Inspection of materiel in the hands of troops	Direct and general support inspections		Action	Reference
	Spot-Check	Initial		
			area and forcing cone area are cause for rejection. Large pits are defined as those 1/8 inch or more in diameter and approximately 1/64 inch in depth, as determined by visual inspection.	
X	X	X	(11) Check headspace, using headspace gage 7799734.	Fig 3-14
—	X	X	(12) Check bore straightness, using straightness gage 8448202. The gage must pass freely through the barrel bore with the barrel in vertical position.	
			d. <i>Front Sight and Gas Tube</i>	
X	X	(1) Check front sight for looseness, cracks, and general condition.	
X	X	(2) Check gas tube for cracks and evidence of gas leakage around front sight.	
			3. BOLT CARRIER GROUP	
			NOTE	
			Do NOT interchange bolt assemblies between rifles.	
X	X	a. Check for cracks in bolt (cam pin hole area).	
X	X	b. Inspect bolt for pitted or chipped bolt face, and elongated firing pin hole.	
			NOTE	
			Bolts, that contain pits extending into the firing pin hole or group clusters of minute pits, will be rejected. Bolts that contain minute individual pits of a scattered pattern, shall not be cause for rejection.	
X	X	X	c. Each bolt locking lug should be inspected periodically for cracks. Use a black light if available, otherwise use a glass of no more than 3X magnification. Particular attention must be given to the area where the lug meets the bolt body. Bolts with lugs exhibiting cracking, or which are a definite suspect, will be replaced.	
X	X	X	d. Inspect for broken bolt rings and proper spacing in ring gaps. Ring gaps are to be staggered to prevent loss of gas pressure.	
X	X	e. Inspect firing pin tip for proper contour, wear and burs.	
X	X	X	f. Check firing pin protrusion, using firing pin protrusion gage 7799735; should be between 0.028 and 0.036 of an inch.	Fig 3-15.
X	X	X	g. Inspect extractor for cracks and for broken extractor spring.	
X	X	h. Check bolt carrier for cracks, burs, and chips.	Fig 3-5.
X	X	X	i. Check carrier and key screws. They must be staked.	Fig 3-5.
			4. LOWER RECEIVER GROUP	
			a. <i>General</i>	
X	X	(1) Inspect for cracks, corrosion, or mutilation which would affect functioning. Small dents or gouges will not be cause for rejection.	Figs 3-16 and 3-17.
X	X	(2) Inspect all parts for wear and damage.	
X	X	X	(3) Check springs for breaks, rust and deformation.	
—	X	X	(4) Check trigger pull, using fixture 7274758. Minimum 5.0 lbs, maximum 8.5 lbs.	
X	X	X	(5) Inspect receiver for corrosion in the lobes of the pivot or hinge pin area. If extensive corrosion appears in these areas the receiver will not be repaired and rifle will be turned in for replacement.	B and C, fig 3-17.
X	X	X	(6) Inspect receiver for breakthrough of metal. If receiver contains cracks or holes it will not be repaired and rifle will be turned in for replacement.	C, fig. 3-16.
X	X	X	(7) Inspect receiver and receiver extension for initial loss of protective coating. For repair see table 3-1.	A, fig. 3-16 and
			b. <i>Stock assembly</i>	A, fig. 3-18.
X	X	(1) Inspect for breaks and separations of material which prevent proper retention or interference with proper functioning of weapon.	

Table 3-3. Maintenance Inspections — Continued

Inspection of materiel in the hands of troops	Direct and general support inspections		Action	Reference
	Spot-Check	Initial		
X	X	(2) Inspect for dents, cracks and chipping that would impair the functioning of components or weapon. (3) Inspect cracks in other than critical areas, not exceeding three inches in length and a width of not more than 1/16 inch. Inspect for dents, gouges, or crushed areas. 5. BIPOD a. Inspect the bipod legs, they shall move freely from closed to open position under spring tension. Inspect for rust. Remove rust and touch up shiny areas, using solid film lubricant. b. Bipod must hold securely to the rifle.	Fig 3-11 and table 3-1.
X	X		
X	X		
X	X		

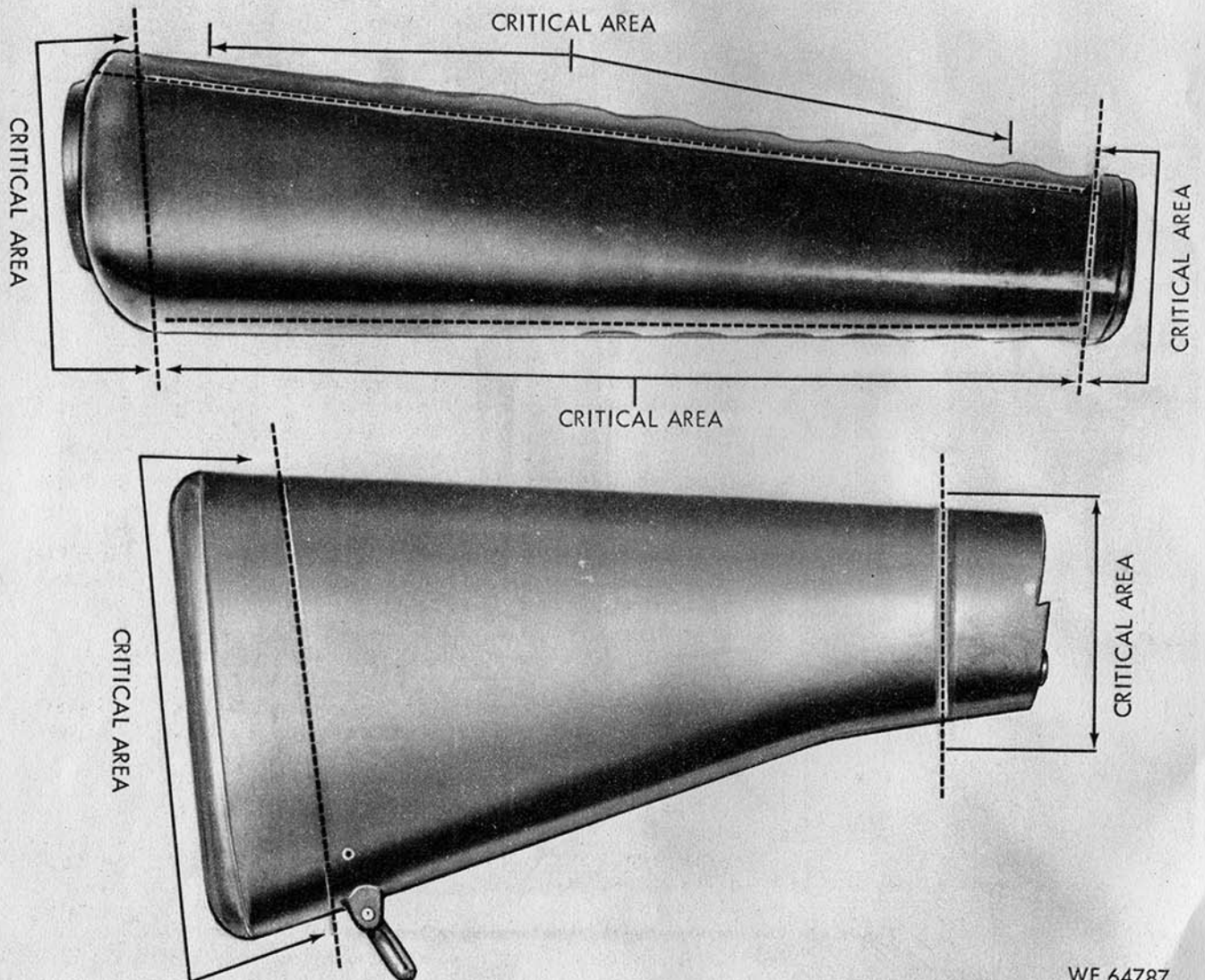

WE 64787

Figure 3-11. Critical areas of stock assembly and hand guard.

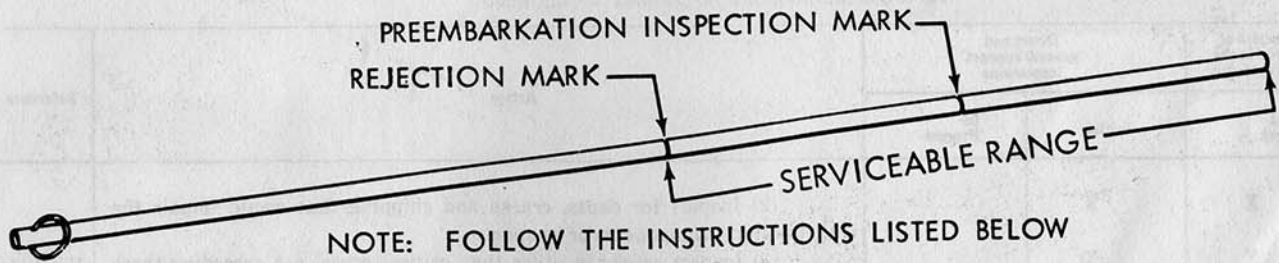

NOTE: FOLLOW THE INSTRUCTIONS LISTED BELOW

1. REMOVE RIFLE BOLT.
2. INSERT GAGE INTO BREECH.
3. SIGHT ALONG FRONT FACE OF MAGAZINE WELL IN RECEIVER.
4. RIFLE WILL NOT ACCOMPANY TROOPS OVERSEAS IF GAGE GOES PAST PREEMBARKATION INSPECTION MARK.

WE 16094

Figure 3-12. Checking barrel erosion.



Figure 3-13. Visually inspecting the chamber using reflector tool.

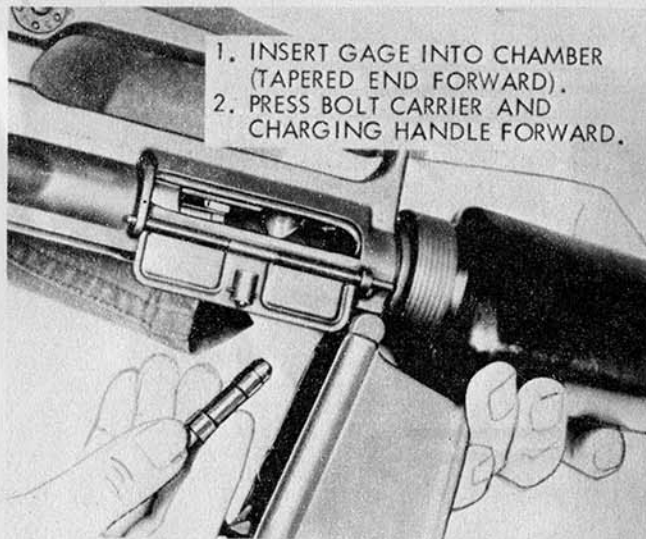

1. Inserting headspace gage.

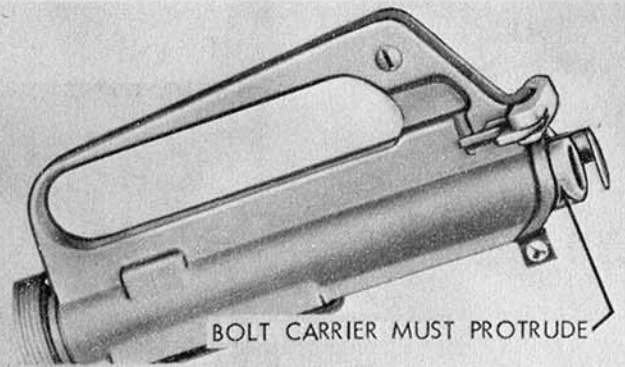

2. Correct headspace.

NOTE: APPLY ONLY A LIGHT PRESSURE TO BOLT CARRIER.

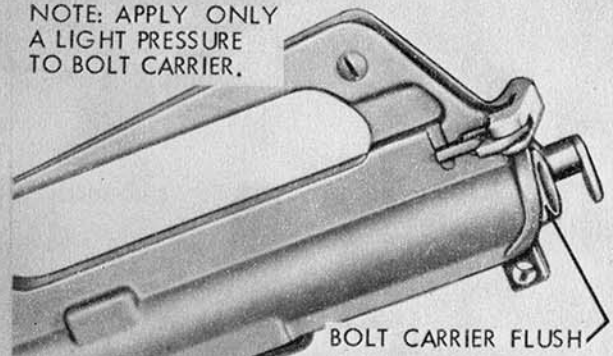

3. Incorrect headspace.

WE 13636A

Figure 3-14. Checking headspace with headspace gage.

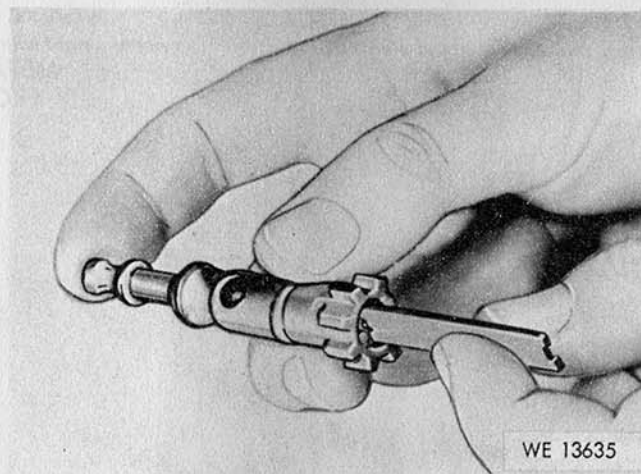
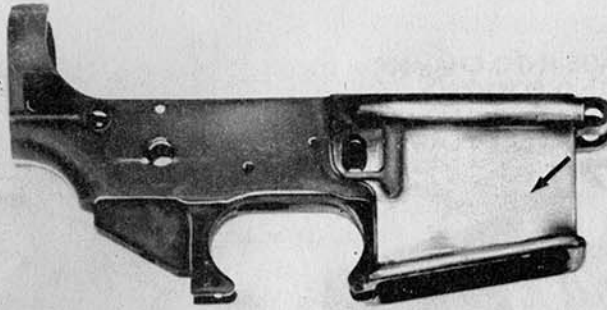

Figure 3-15. Check bolt with firing pin protrusion gage.



A - SHINY SURFACES - REPAIRABLE



B - CORRODED AND NO HOLES - REPAIRABLE



C - CORRODED WITH HOLE - NON-REPAIRABLE

WE 70300

Figure 3-16. Repairable and non-repairable lower receivers—right side view.

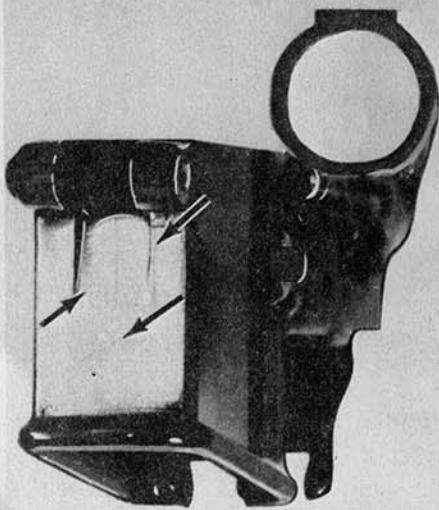

A - SHINY SURFACES - REPAIRABLE



B - CORRODED - REPAIRABLE

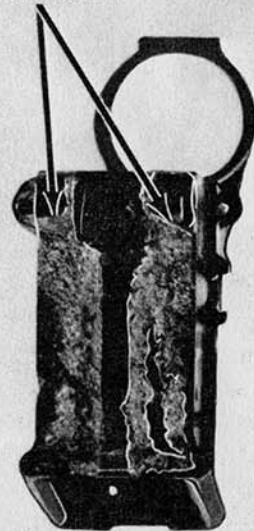

C - CORRODED LOBES - WEAKENING PIVOT PIN AREA NON-REPAIRABLE

WE 64563

Figure 3-17. Repairable and non-repairable lower receivers — end view.

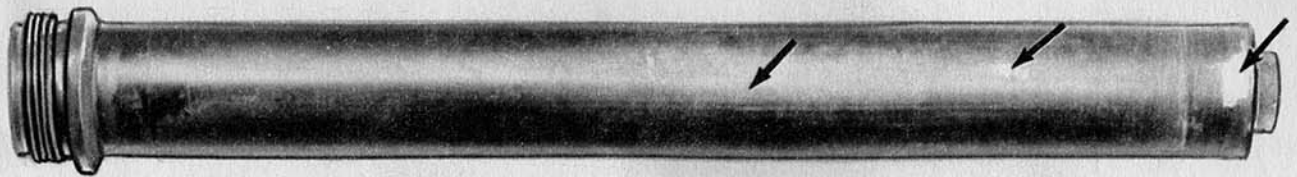

A - SHINY SURFACES - REPAIRABLE

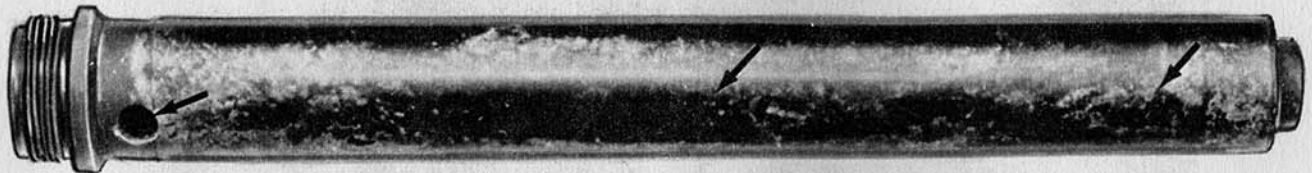

B - CORRODED - REPAIRABLE

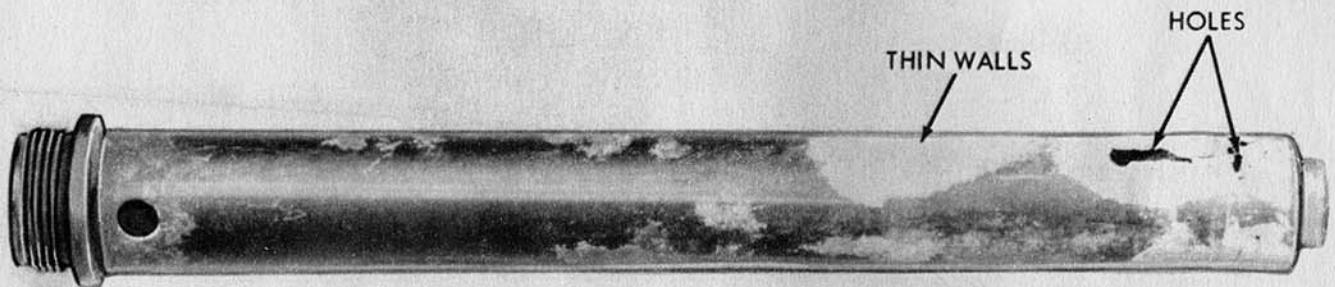

C - HOLES AND THIN WALLS - NON-REPAIRABLE

WE 64562

Figure 3-18. Repairable and non-repairable lower receiver extensions—right side view.

Section III. REPLACEMENT OF PARTS

3-9. General

Replace all metal parts that are damaged, cracked or broken. All replacement parts are interchangeable and require no adjustment when being installed in the rifles. However, to insure proper functioning and reliability, the following precautions should be taken:

a. Unless replacement is necessary, do not interchange bolts and bolt carriers. Keep the bolt with the original bolt carrier.

b. If replacement of either part becomes necessary, carefully check the new part to see that it fits

properly, operates smoothly and the proper head-space is provided (fig. 3-14).

c. If one or more rings of bolt assembly are damaged, replace all rings.

d. When assembling a bolt with new rings into the bolt carrier, rotate the bolt to prevent damaging the rings. Move the bolt in and out several times to seat the rings.

e. If the bolt carrier key is replaced, it may be necessary to create a seal between the bolt carrier and key by firing 3-8 rounds. Manual operation of the rifle may be required.

CHAPTER 4

MAINTENANCE OF MATERIEL USED IN CONJUNCTION WITH MAJOR ITEM

4-1. General

a. The Bayonet-Knife M7, Bayonet-Knife Scabbard M8A1, and 40-MM Grenade Launcher M203 are used in conjunction with the major item.

b. Refer to TM 9-1010-221-24 or organizational, DS and GS maintenance for the grenade launcher.

4-2. Direct and General Support Maintenance

a. *Disassembly/Assembly (Bayonet-Knife M7).*
Refer to figure 4-1.

NOTE

Prior to disassembly, it is recommended that the right hand release and plate be marked to assist in identification when assembling the left and right hand releases. See figure 4-2.

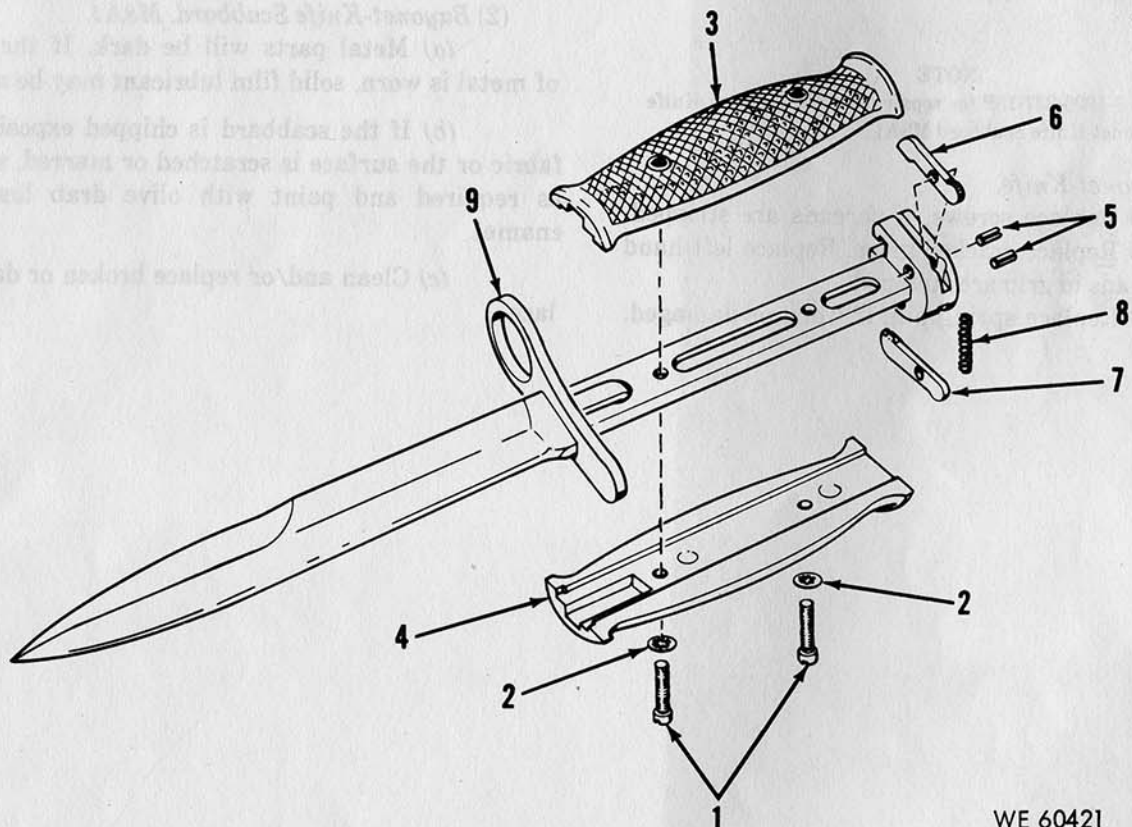

WE 60421

- Key to fig. 4-1:
 1. Screw, grip
 2. Washer, lock
 3. Grip
 4. Grip
 5. Pin, spring
 6. Release
 7. Release
 8. Spring
 9. Blade assembly

Figure 4-1. Bayonet-Knife, M7—exploded view.

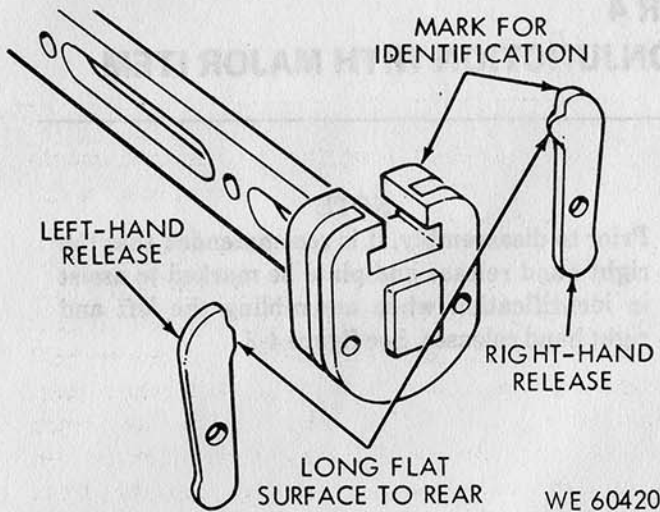

Figure 4-2. Bayonet-Knife—marking and identification of releases.

- b. *Cleaning.* Refer to TM 9-1005-249-20.
- c. *Inspection and Repair.*

NOTE

Refer to TM 9-1005-237-15P for repair parts for Bayonet-Knife M7 and Bayonet-Knife Scabbard M8A1.

(1) *Bayonet-Knife.*

- (a) Replace screws, if threads are stripped.
- (b) Replace cracked grips. Replace left-hand grip, if threads in grip are stripped.
- (c) Replace spring pin, if worn or damaged.

- (d) Replace spring if kinked, set, or broken.
- (e) Remove nicks and dents, as required, by grinding and/or stoning.

(f) If wear is noted on the release camming area and positive retention to the rifle is questionable, replace as required. If binding is noted due to a bent release, repair by straightening or replace release.

(g) Use solid film lubricant if shiny surfaces are on handle of blade.

(h) Plates that are loose on the blade and cannot be tightened by staking or peening will be repaired by spot or arc welding. Make certain when repairing, that sufficient clearance exists after repair, to permit positive retention of the bayonet to the rifle.

(i) Loose guards will be repaired by swaging the link, using a pin punch and hammer.

(2) *Bayonet-Knife Scabbard, M8A1.*

(a) Metal parts will be dark. If the finish of metal is worn, solid film lubricant may be applied.

(b) If the scabbard is chipped exposing the fabric or the surface is scratched or marred, smooth as required and paint with olive drab lusterless enamel.

(c) Clean and/or replace broken or damaged lace.

CHAPTER 5 FINAL INSPECTION

5-1. General

This chapter contains instructions for final acceptance of repaired rifles and bipod. As applicable, the rifles and bipod must be checked in accordance with procedures outlined in table 3-3 and in paragraph a through c, below. Rifles that have been repaired should be function fired, whenever possible, to assure proper function. Rifles that have been rebarreled should be both, function fired and fired for accuracy.

a. *Visual Inspection.* Overall appearance will be approximately that of a new weapon. All exposed metal surfaces are to have a dull, rust or corrosion resistant finish with no burs or deep scratches. Barrels must be straight, clean, free of rust, powder fouling, and free of bulges and rings. Fine pitting is allowable, however, rifles must be complete with no missing parts. All applicable modifications must be applied. The serial numbers must be legible. All steel parts must be free of rust. Spring pins must be secure and screws must be tight.

b. *Functional Inspection.*

(1) Make a functional check of the rifles while the selector lever is in the Safe, Semi, and Auto position. The following sequence is used for a rapid, complete check. Any portion of this check may be used alone to determine the operational condition of any specific fire selection.

NOTE

Disengage the take down pin and open receivers. Hammer shall be in cocked position.

(2) Place selector lever in Safe position, pull trigger, hammer should not fall.

(3) Place selector lever in Semi position. Pull trigger, hammer should fall. Hold trigger to rear,

recock hammer and release trigger. Hammer should transfer from hammer hooks and disconnecter to the hammer notch and trigger nose.

(4) Place selector lever in Auto position. Pull trigger, hammer should fall. Hold trigger to the rear and recock the hammer. Upper hammer hook is now engaged with the automatic sear. Continue to hold trigger to rear, push forward on automatic sear. Hammer should fall. Hold trigger to the rear, recock hammer, release trigger and push forward on automatic sear. Hammer should transfer from hammer hook and automatic sear to hammer notch and trigger nose. Move selector lever to Safe position. Close receivers and engage take down pin.

CAUTION

Failure to move selector lever to Safe or Semi position before closing receivers will damage automatic sear.

(5) Place selector lever in Semi position, pull charging handle to the rear. Make certain chamber is clear, then release charging handle, pull the trigger, hammer should fall.

(6) Check function of magazine catch button, make certain it functions properly.

(7) Check function of bolt catch, make certain it operates smoothly and holds the bolt carrier in open position.

(8) Check front and rear sights, make certain they can be adjusted properly.

(9) Actuate the forward assist assembly (M16A1 only). It must work freely.

c. *Gage Inspection.* Check headspace, firing pin protrusion and barrel erosion (table 3-3).

APPENDIX A REFERENCES

A-1. Publications Indexes

The following indexes should be consulted for the latest changes, revisions of references given in this appendix and new publications relating to material covered in this manual.

Military Publications:

Index of Administrative Publications	DA Pam 310-1
Index of Blank Forms	DA Pam 310-2
Index of Doctrinal, Training, and Organizational Publications	DA Pam 310-3
Index of Supply Catalogs and Supply Manuals (excluding types 7, 8 and 9)	DA Pam 310-6
Index of Technical Manuals, Technical Bulletins, Supply Manuals (types 7, 8 and 9), Supply Bulletins and Lubrication Orders	DA Pam 310-4
U.S. Army Equipment Index of Modification Work Orders	DA Pam 310-7

A-2. Forms

The following form pertains to this materiel:

DA Form 2028, Recommended Changes to Publications.

A-3. Other Publications

The following explanatory publications pertain to the materiel:

The M16A1 Rifle: Operational and Preventive Maintenance	DA Pam 750-30
Army Maintenance, Management Systems (TAMMS)	TM 38-750
Standards for Oversea Shipment or Domestic Issue of Small Arms, Aircraft Armament, Towed Howitzers, Mortars, Recoilless Rifles, Rocket Launchers and Associated Fire Control Equipment	TB 9-1000-247-35
Organizational, DS, GS, and Depot Maintenance Repair Parts and Special Tools List: Bayonet-Knife M4, M5, M5A1, M6 and M7, with Bayonet-Knife Scabbard M8A1	TM 9-1005-237-15P
Operator's Manual M16A1 Rifle	TM 9-1005-249-10
Organizational Maintenance Manual Including Repair Parts and Special Tools Lists, Rifle, 5.56-MM, M16A1, W/E (1005-073-9421), Rifle, 5.56-MM, M16 (1005-856-6885), Bipod, Rifle, M3 W/Carrying Case (1005-890-2609)	TM 9-1005-249-20
Maintenance Assistance and Instruction Team (MAIT) Program	AR 750-51

A-4. Related Publications

Operator, Organizational and DS Maintenance Manual: Night Vision Sight, Individual Served Weapon, AN/PVS-1	TM 11-1090-268-13
Operator's Organizational and DS Maintenance Manual Including Repair Parts and Special Tools Lists: Night Vision Sight Individual Served Weapons AN/PVS-2 and AN/PVS-2A	TM 11-5855-203-13

APPENDIX B

DIRECT SUPPORT AND GENERAL SUPPORT MAINTENANCE REPAIR PARTS AND SPECIAL TOOLS LIST (INCLUDING DEPOT MAINTENANCE REPAIR PARTS AND SPECIAL TOOLS)

Section I. INTRODUCTION

B-1. Scope

This appendix lists repair parts, special tools, and equipment, required for the performance of direct support, general support, and depot maintenance of the Rifles M16, M16A1 and Rifle, Bipod, M3.

B-2. General

This Repair Parts and Special Tools List is divided into the following sections:

a. *Repair Parts List—Section II.* A list of repair parts authorized at the direct support, general support, and depot levels for the performance of maintenance. The list also includes parts which must be removed for the replacement of the authorized parts. Parts lists are composed of functional groups in ascending numerical sequence, with parts in each group listed in figure and item number sequence.

b. *Special Tools List—Section III.* A list of special tools, test and support equipment authorized for the performance of maintenance at the direct support, general support, and depot levels.

c. *Federal Stock Number and Reference Number Index—Section IV.* A list, in ascending numerical sequence, of all Federal stock numbers appearing in the listings, followed by a list, in alphameric sequence, of all reference numbers appearing in the listings. Federal stock number and reference numbers are cross-referenced to each illustration figure and item number appearance.

B-3. Explanation of Columns

The following provides an explanation of columns found in the tabular listings.

a. *Source, Maintenance, and Recoverability Codes (SMR).*

(1) *Source Code.* Indicates the source for the listed items. Source codes are:

Code	Explanation
P	Repair parts, special tools and test equipment supplied from the GSA/DSA, or Army supply system and authorized for use at indicated maintenance categories.

Code	Explanation
P2	Repair parts, special tools and test equipment which are procured and stocked for insurance purposes because the combat or military essentiality of the end item dictates that a minimum quantity be available in the supply system.
P9	Assigned to items which are NSA design controlled: unique repair parts, special tools, test, measuring, and diagnostic equipment which are stocked and supplied by the Army COMSEC Logistic System and which are not subject to the provisions of AR 380-41.
P10	Assigned to items which are NSA design controlled: special tools, test, measuring, and diagnostic equipment for COMSEC support which are accountable under the provisions of AR 380-41 and which are stocked and supplied by the Army COMSEC Logistic System.
M	Repair parts, special tools and test equipment which are not procured or stocked as such in the supply system but are to be manufactured at indicated maintenance levels.
A	Assemblies which are not procured or stocked as such but are made up of two or more units. Such component units carry individual stock numbers and descriptions, are procured and stocked separately, and can be assembled to form the required assembly at indicated maintenance categories.
X	Parts and assemblies that are not procured or stocked because the failure rate is normally below that of the applicable end item or component. The failure of such part or assembly should result in retirement of the end item from the supply system.
X1	Repair parts which are not procured or stocked. The requirement for such items will be filled by the next higher assembly or component.
X2	Repair parts, special tools and test equipment which are not stocked and have no foreseen mortality. The indicated maintenance category requiring such repair parts will attempt to obtain the parts through cannibalization or salvage. The item may be requisitioned, with exception data, from the end item manager for immediate use.
G	Major assemblies that are procured with PEMA funds for initial issue only as exchange assemblies at DS and GS level. These assemblies will not be stocked above DS and GS level or returned to depot supply level.

NOTE

Cannibalization or salvage may be used as a source of supply for any items source coded above except those coded X1 and aircraft support items as restricted by AR 700-42.

(2) *Maintenance Code*. Indicates the lowest category of maintenance authorized to install the repair part and/or use the special tool or test equipment for each application. Capabilities of higher maintenance categories are considered equal or better.

Maintenance codes are:

Code	Explanation
C	Crew/operator
O	Organizational maintenance
F	Direct support maintenance
H	General support maintenance
D	Depot maintenance

(3) *Recoverability Code*. Indicates whether unserviceable items should be returned for recovery or salvage. Items not coded are nonrecoverable. Recoverability codes are:

Code	Explanation
R	Repair parts (assemblies and components), special tools and test equipment which are considered economically repairable at direct and general support maintenance levels. When the item is no longer economically repairable, it is normally disposed of at the GS level. When supply considerations dictate, some of these repair parts may be listed for automatic return to supply for depot level repair as set forth in AR 710-50. When so listed, they will be replaced by supply on an exchange basis.
S	Repair parts, special tools and test equipment and assemblies which are economically repairable at DS and GS activities and which normally are furnished by supply on an exchange basis. When items are determined by a GSU to be uneconomically repairable, they will be evacuated to a depot for evaluation and analysis before final disposition.
T	High dollar value recoverable repair parts, special tools and test equipment which are subject to special handling and are issued on an exchange basis. Such items will be repaired or overhauled at depot maintenance activities only. No repair may be accomplished at lower levels.
U	Repair parts, special tools and test equipment specifically selected for salvage by reclamation units because of precious metal content, critical materials, high dollar value, or reusable casings or castings.

b. *Federal Stock Number*. Indicates the Federal stock number assigned to the item and will be used for requisitioning purposes.

c. *Description*. Indicates the Federal item name and a minimum description required to identify the item. The last line indicates the reference number followed by the applicable Federal Supply Code for Manufacturer (FSCM) in parentheses. The FSCM is used as an element in item identification to designate manufacturer or distributor or Government agency, etc., and is identified in SB 708-42. Items that are included in kits and sets are listed below the name of the kit or set with quantity of each item in the kit or set indicated in front of the item name.

d. *Unit of Measure (U/M)*. Indicates the standard or basic quantity by which the listed item is used in performing the actual maintenance function. This measure is expressed by a two-character alphabetical abbreviation, e.g., ea, in, pr, etc., and is the basis used to indicate quantities and allowances in subsequent columns. When the unit of measure differs from the unit of issue, the lowest unit of issue that will satisfy the required units of measure will be requisitioned.

e. *Quantity Incorporated in Unit*. Indicates the quantity of the item used in the breakout shown on the illustration figure, which is prepared for a functional group, subfunctional group, or an assembly. A "V" appearing in this column in lieu of a quantity indicates that no specific quantity is applicable, e.g., shims, spacers, etc.

f. *30-Day DS/GS Maintenance Allowances*.

NOTE

Allowances in GS Column are for GS Maintenance only. The allowance columns are divided into three sub-columns. Items authorized for use are identified with an asterisk in the allowance column opposite the first appearance of each item. Subsequent appearances of the same item will have the letters "REF" in the applicable allowance columns.

g. *1-Year Allowances Per 100 Equipments/Contingency Planning Purposes*. This column indicates opposite the first appearance of each item the authorization for distribution and contingency planning purposes. The range of items indicates the authorization of all items required to provide for adequate support of 100 equipments for one year. Subsequent appearances of the same item will have the letters "REF" in this column.

h. *Depot Maintenance Allowance Per 100 Equipments*. This column indicates opposite the first appearance of each item the total authorization for depot maintenance of 100 equipments. Items authorized for use are identified with an asterisk. Subsequent appearances of the same item will have the letters "REF" in this column.

i. *Illustration*. This column is divided as follows:

- (1) *Figure Number*. Indicates the figure number of the illustration on which the item is shown.
- (2) *Item Number*. Indicates the callout number used to reference the item on the illustration.

B-4. Special Information

a. Usable on codes are included in Column 3. Uncoded items are applicable to all models. Identifications of the usable on codes used in this publication are:

Code	Used on
A	M16
B	M16A1

b. Detailed assembly instructions for items source coded "A" are found in the maintenance portion of this manual. (See figures 3-2 and 3-5.) Assembly components are listed immediately following the item to be assembled.

c. Action change codes indicated in the left-hand margin of the listing page denote the following:

- N — Indicates an added item.
- C — Indicates a change in data.
- R — Indicates a change in FSN only.

B-5. How to Locate Repair Parts

a. When federal stock number or reference number is unknown:

(1) *First.* Using the table of contents determine the functional group or functional subgroup within which the repair part belongs. This is necessary since illustrations are prepared for functional groups and listings are divided into the same groups.

(2) *Second.* Find the illustration covering the functional group to which the repair part belongs.

(3) *Third.* Identify the repair part on the illustration and note the illustration figure and item number of the repair part.

(4) *Fourth.* Using the Repair Parts Listing find the functional group to which the repair part belongs

and locate the illustration figure and item number noted on the illustration.

b. When Federal stock number or reference number is known:

(1) *First.* Using the Index of Federal Stock Numbers and Reference Numbers find the pertinent federal stock number or reference number. This index is in ascending FSN sequence followed by a list of reference numbers in ascending alphameric sequence, cross-referenced to the illustration figure number and item number.

(2) *Second.* Using the Repair Parts Listing, find the functional group of the repair part and the illustration figure number and item number referenced in the Index of Federal Stock Numbers and Reference Numbers.

B-6. Abbreviations

<i>Abbreviations</i>	<i>Explanation</i>
cd-pltd	cadmium plated
cres	corrosion resistant steel
dld-f-lkg	drilled for locking
NF	National fine (thread)
pass-fin	passivated finish
phos-ctd	phosphate coated
S	steel

Section II. REPAIR PARTS LIST

(1) Source Maint and Recov Code			(2) Federal stock No	(3) Description Reference Number & Mfr Code Usable on Code	(4) Unit of meas	(5) Qty in unit	(6) 30-Day DS maint allowance			(7) 30-Day GS maint allowance			(8) 1-Yr alw per 100 equip entry	(9) Depot maint alw per 100 equip	(10) Illustration	
(a) Source	(b) Maint	(c) Recov					(a) 1-20	(b) 21-50	(c) 51-100	(a) 1-20	(b) 21-50	(c) 51-100			(a) Fig. No.	(b) Item No.
C	P	C	1005-921-5004	RIFLES, 5.56-MM, M16 AND M16A1 MAGAZINE ASSEMBLY: (30 CARTRIDGE CAPACITY) 8448670 (19204)	EA	1	*	*	*	*	*	*	*	*	B-1	
✓	C	P	O	✓	1005-017-9546	UPPER RECEIVER GROUP HANDLE, CHARGING: BOLT CARRIER 8448517 (19204)	EA	1	*	*	*	*	*	*	B-2	1
✓	C	P	F	✓	5315-282-3642	PIN, SPRING: TUBULAR, SLOTTED, S, PHOS-CTD, 1/16 NOM DIA, 1/4 LG MS 16562-96 (96906)	EA	3	*	*	*	*	*	*	B-2	2
✓	C	P	F	✓	1005-999-0405	LATCH, CHARGING HANDLE: 8448519 (19204)	EA	1	*	*	*	*	*	*	B-2	3
✓	C	P	F	✓	1005-999-0404	SPRING, CHARGING HANDLE LATCH: 8448520 (19204)	EA	1	*	*	*	*	*	*	B-2	4
✓	C	X1	F	HANDLE: 8448518 (19204)		1	B-2	5
C	P	O	✓	1005-056-2252	GUARD, HAND, GUN: R.H. BLACK 8448561 (19204)	EA	1	*	*	*	*	*	*	*	B-2	6
C	P	O	✓	1005-056-2251	GUARD, HAND, GUN: L.H. BLACK 8448557 (19204)	EA	1	*	*	*	*	*	*	*	B-2	7
C	P	F	✓	1005-933-8089	SUPPRESSOR, FLASH: CLOSED END 8448576 (19204)	EA	1	*	*	*	*	*	*	*	B-2	8
C	P	F	✓	1005-992-7280	WASHER, LOCK, FLASH SUPPRESSOR: 8448577 (19204)	EA	1	*	*	*	*	*	*	*	B-2	9
C	P	F	R	1005-152-3441	BARREL AND SIGHT ASSEMBLY: 8448663 (19204)	EA	1	*	*	*	*	*	*	*	B-2	10
C	P	F	✓	1005-979-3926	PIN, FRONT SIGHT, TAPERED: 8448575 (19204)	EA	2	*	*	*	*	*	*	*	B-2	11
C	P	F	✓	1005-979-3924	CAP, HAND GUARD: 8448564 (19204)	EA	1	*	*	*	*	*	*	*	B-2	12
P	F	✓	5315-058-6044	PIN, SPRING: TUBULAR, SLOTTED, S, PHOS-CTD, 5/64 NOM DIA, 5/16 LG MS16562-106 (96906)	EA	1	*	*	*	*	*	*	*	*	B-2	13
C	P	F	✓	1005-978-1038	TUBE, GAS: 8448567 (19204)	EA	1	*	*	*	*	*	*	*	B-2	14
P	O	X	5320-055-3066	RIVET, TUBULAR: OVAL-HEAD, S, CD-PLTD, 0.123 NOM SIZE, 0.531 LG (FRONT SWIVEL) MS 16535-125 (96906)	EA	1	*	*	*	*	*	*	*	*	B-2	15
C	P	O	✓	1005-017-9543	SWIVEL, GUN, SLING: UPPER AND LOWER RECEIVER 8448571 (19204)	EA	1	*	*	*	*	*	*	*	B-2	16
C	P	F	✓	1005-979-3929	POST, FRONT SIGHT: 8448572 (19204)	EA	1	*	*	*	*	*	*	*	B-2	17
C	P	F	✓	1005-979-3930	DETENT, FRONT SIGHT: 8448573 (19204)	EA	1	*	*	*	*	*	*	*	B-2	18
C	P	F	✓	1005-979-3931	SPRING, FRONT SIGHT, DETENT: 8448574 (19204)	EA	1	*	*	*	*	*	*	*	B-2	19

Section II. REPAIR PARTS LIST—Continued

TM 9-1005-249-34

(1) Source Maint and Recov Code			(2) Federal stock No.	(3) Description Reference Number & Mfr Code U'sable on Code	(4) Unit of meas	(5) Qty inc in unit	(6) 30-Day DS maint allowance			(7) 30-Day GS maint allowance			(8) 1-Yr aw per 100 equip entree	(9) Depot maint aw per 100 equip	(10) Illustration	
(a) Source	(b) Maint	(c) Recov					(a) 1-20	(b) 21-50	(c) 51-100	(a) 1-20	(b) 21-50	(c) 51-100			(a) Fig. No.	(b) Item No.
				UPPER RECEIVER GROUP— Continued												
C	X1	F		SIGHT, FRONT: 8448566 (19204)		1									B-2	20
C	X1	F		BARREL ASSEMBLY: 8448548 (19204)		1									B-2	21
	A	F		NUT ASSEMBLY, BARREL: 62113		1									B-2	22
C	P	F	5365-999-0863	RING, RETAINING: EXT, TAPERED SECTION TYPE, S, PHOS-CTD, 1.272 FREE ID 8448665 (19204)	EA	1	*	*	*	*	*	*	*	*	B-2	23
C	P	F	1005-978-1036	SPRING, SLIP RING, HAND GUARD: 8448555 (19204)	EA	1	*	*	*	*	*	*	*	*	B-2	24
C	P	F	1005-978-1034	NUT, BARREL: 8448553 (19204)	EA	1	*	*	*	*	*	*	*	*	B-2	25
C	P	F	1005-978-1035	RING, SLIP, HAND GUARD: 8448554 (19204)	EA	1	*	*	*	*	*	*	*	*	B-2	26
C	P	F	1005-978-1023	PIN, EJECTION PORT COVER: 8448533 (19204)	EA	1	*	*	*	*	*	*	*	*	B-2	27
	P	F	5365-999-0864	RING, RETAINING: EXT, REDUCED SECTION TYPE S, PHOS-CTD, 0.102 FREE ID MS 16632-3012 (96906)	EA	1	*	*	*	*	*	*	*	*	B-2	28
C	P	F	1005-978-1025	SPRING, EJECTION PORT COVER: 8448532 (19204)	EA	1	*	*	*	*	*	*	*	*	B-2	29
C	P	F	1005-978-1022	COVER, EJECTION PORT: 8448525 (19204)	EA	1	*	*	*	*	*	*	*	*	B-2	30
	P	F	5315-282-3642	PIN, SPRING: TUBULAR, SLOTTED, S, PHOS-CTD, 1/16 NOM, DIA, 1/4 LG MS 16562-96 (96906)	EA	1	REF	REF	REF	REF	REF	REF	REF	*	B-2	31
C	P	F	1005-978-1029	DRUM, REAR SIGHT WIND- AGE: 8448535 (19204)	EA	1	*	*	*	*	*	*	*	*	B-2	32
C	P	F	1005-978-1030	DETENT, REAR SIGHT: 8448537 (19204)	EA	1	*	*	*	*	*	*	*	*	B-2	33
C	P	F	1005-978-1032	SPRING, DETENT, REAR SIGHT: 8448538 (19204)	EA	1	*	*	*	*	*	*	*	*	B-2	34
C	P	F	1005-978-1028	SCREW, REAR SIGHT WIND- AGE: 8448534 (19204)	EA	1	*	*	*	*	*	*	*	*	B-2	35
C	P	F	1005-978-1026	SIGHT, REAR: 8448539 (19204)	EA	1	*	*	*	*	*	*	*	*	B-2	36
C	P	F	1005-978-1027	SPRING, REAR SIGHT: 8448536 (19204)	EA	1	*	*	*	*	*	*	*	*	B-2	37
	P	F	5315-840-3812	PIN, SPRING: TUBULAR, SLOTTED, S, PHOS-CTD, 3/32 NOM DIA, 5/8 LG MS 16562-121 (96906)	B	1	*	*	*	*	*	*	*	*	B-2	38
C	A	F		FORWARD ASSIST ASSEMBLY: 8448541 (19204)	B	1									B-2	39
C	P	F	1005-017-9541	SPRING, PLUNGER: UPPER RECEIVER 8448540 (19204)	EA	1	*	*	*	*	*	*	*	*	B-2	40

Section II. REPAIR PARTS LIST—Continued

(1) Source Maint and Recov Code			(2) Federal stock No.	(3) Description Reference Number & Mfr Code Usable on Code	(4) Unit of meas	(5) Qty inc in unit	(6) 30-Day DS maint allowance			(7) 30-Day GS maint allowance			(8) 1-Yr alw. per 100 equip cntgcy	(9) Depot maint alw per 100 equip	(10) Illustration		
(a) Source	(b) Maint	(c) Recov					(a) 1-20	(b) 21-50	(c) 51-100	(a) 1-20	(b) 21-50	(c) 51-100			(a) Fig. No.	(b) Item No.	
P	F		5315-282-3642	UPPER RECEIVER GROUP— Continued PIN, SPRING: TUBULAR, SLOTTED, S, PHOS-CTD, 1/16 NOM DIA, 1/4 LG MS 16562-96 (96906)	EA	1	REF	REF	REF	REF	REF	REF	REF	*	B-2	41	
C	P	F	1005-017-9539	PAWL, FORWARD ASSIST: UPPER RECEIVER 8448543 (19204)	EA	1	*	*	*	*	*	*	*	*	*	B-2	42
C	P	F	1005-017-9540	DETENT, PAWL: UPPER RECEIVER 8448544 (19204)	EA	1	*	*	*	*	*	*	*	*	*	B-2	43
C	P	F	1005-523-8084	SPRING, BOLT: 8448542 (19204)	EA	1	*	*	*	*	*	*	*	*	*	B-2	44
C	P	F	1005-017-9538	PLUNGER, ASSEMBLY: UPPER RECEIVER 8448545 (19204)	EA	1	*	*	*	*	*	*	*	*	*	B-2	45
C	P	F	1005-017-9550	RECEIVER, UPPER: 8448603 (19204)	EA	1	*	*	*	*	*	*	*	*	*	B-2	46
C	P	F	1005-017-9542	RECEIVER, UPPER: 8448524 (19204)	EA	1	*	*	*	*	*	*	*	*	*	B-2	47
C	P	O	5315-999-1509	BOLT CARRIER GROUP PIN, FIRING PIN RETAINING: 8448504 (19204)	EA	1	*	*	*	*	*	*	*	*	*	B-3	1
C	P	O	1005-017-9547	PIN, FIRING: BOLT CARRIER 8448503 (19204)	EA	1	*	*	*	*	*	*	*	*	*	B-3	2
C	P	O	1005-992-7294	PIN, BOLT CAM: 8448502 (19204)	EA	1	*	*	*	*	*	*	*	*	*	B-3	3
C	P	F	1005-992-7285	BOLT ASSEMBLY: 8448509 (19204)	EA	1	*	*	*	*	*	*	*	*	*	B-3	4
C	P	O	1005-992-7290	PIN, EXTRACTOR: 8448513 (19204)	EA	1	*	*	*	*	*	*	*	*	*	B-3	5
C	P	O	1005-992-7288	EXTRACTOR, SMALL ARMS CARTRIDGE: 8448512 (19204)	EA	1	*	*	*	*	*	*	*	*	*	B-3	6
C	P	O	1005-992-7289	SPRING, EXTRACTOR: 8448514 (19204)	EA	1	*	*	*	*	*	*	*	*	*	B-3	7
P	O		5315-514-2358	PIN, SPRING: TUBULAR, SLOTTED, S, PHOS-CTD, 1/16 NOM DIA, 7/16 LG MS 16562-99 (96906)	EA	1	*	*	*	*	*	*	*	*	*	B-3	8
C	P	O	1005-992-7291	EJECTOR, SMALL ARMS CARTRIDGE: 8448515 (19204)	EA	1	*	*	*	*	*	*	*	*	*	B-3	9
C	P	O	1005-992-7292	SPRING, EJECTOR AND SELECTOR LEVER DETENT: 8448516 (19204)	EA	1	*	*	*	*	*	*	*	*	*	B-3	10
C	P	F	1005-992-7287	RING, BOLT: 8448511 (19204)	EA	3	*	*	*	*	*	*	*	*	*	B-3	11
C	X1	O		BOLT: 8448510 (19204)		1										B-3	12
C	A	F		CARRIER AND KEY: BOLT CARRIER 8448505 (19204)		1										B-3	13
C	P	F	1005-992-7284	SCREW, CARRIER AND KEY: 8448508 (19204)	EA	2	*	*	*	*	*	*	*	*	*	B-3	14
C	P	F	1005-992-7283	KEY, BOLT CARRIER: 8448506 (19204)	EA	1	*	*	*	*	*	*	*	*	*	B-3	15
C	P	F	1005-738-6213	CARRIER, BOLT: 8448507 (19204)	EA	1	*	*	*	*	*	*	*	*	*	B-3	16

Section II. REPAIR PARTS LIST—Continued

TM 9-1005-249-34

(1) Source Maint and Recov Code	(2) Federal stock No.	(3) Description Reference Number & Mfr Code Usable on Code	(4) Unit of meas	(5) Qty inc in unit	(6) 30-Day DS maint allowance			(7) 30-Day GS maint allowance			(8) 1-Yr alw. per 100 equip entury	(9) Depot maint alw per 100 equip	(10) Illustration	
					(a) 1-20	(b) 21-50	(c) 51-100	(a) 1-20	(b) 21-50	(c) 51-100			(a) Fig. No.	(b) Item No.
P O	5305-912-7296	LOWER RECEIVER GROUP SCREW, MACHINE: FIL-HD, DLD-F-LKG WIRE, CRES, PASS-FIN, 1/4-28NF-2A, 1-1/4 LG MS 35276-284 (96906)	HD	1	*	*	*	*	*	*	*	*	B-4	1
P O	5310-527-3634	WASHER, LOCK: FLT-EXT- TEETH, S, PASS-FIN, 1/4 NOM SIZE, 0.267 MAX ID, 0.510 MAX OD, 0.028 MAX THK MS 35335-61 (96906)	HD	1	*	*	*	*	*	*	*	*	B-4	2
C P O	1005-056-2250	GRIP, PISTOL: BLACK 8448632 (19204)	EA	1	*	*	*	*	*	*	*	*	B-4	3
C P O	1005-992-7292	SPRING, EJECTOR AND SELECTOR LEVER DETENT: 8448516 (19204)	EA	1	REF	REF	REF	REF	REF	REF	REF	REF	B-4	4
C P O	1005-992-6667	DETENT, SELECTOR LEVER: 8448631 (19204)	EA	1	*	*	*	*	*	*	*	*	B-4	5
C P O	1005-992-6657	SCREW, BUTT CAP: 8448627 (19204)	EA	1	*	*	*	*	*	*	*	*	B-4	6
N P O	1005-489-0369	BUTT STOCK ASSEMBLY, STOWAGE: 8448650 (19204)	EA	1	*	*	*	*	*	*	*	*	B-4	7
N P F	5305-463-3893	SCREW, MACHINE: 8448654 (19204)	EA	1	*	*	*	*	*	*	*	*	B-4	8
N P F	1005-403-0964	SWIVEL, SLING: 8448652 (19204)	EA	1	*	*	*	*	*	*	*	*	B-4	9
N P F	1005-403-0963	PLATE, BUTT, SHOULDER RIFLE STOCK: 8448656 (19204)	EA	1	*	*	*	*	*	*	*	*	B-4	10
N P F	5315-463-3894	PIN, LATCH PIVOT: 8448655 (19204)	EA	1	*	*	*	*	*	*	*	*	B-4	11
N P F	5340-463-3892	HINGE, ACCESS DOOR: 8448653 (19204)	EA	1	*	*	*	*	*	*	*	*	B-4	12
N P F	1005-403-0962	DOOR ASSEMBLY, STOWAGE: 8448658 (19204)	EA	1	*	*	*	*	*	*	*	*	B-4	13
N X1 F	BUTT STOCK: 8448651 (19204)	EA	1	B-4	14
C P O	1005-017-9549	STOCK ASSEMBLY, BUTT STOWAGE: 8448622 (19204)	EA	1	*	*	*	*	*	*	*	*	B-4	15
P F	5315-898-9823	PIN, SPRING: TUBULAR, SLOTTED, S, PHOS-CTD, 1/8 NOM DIA, 7/8 LG MS 16562-131 (96906)	EA	1	*	*	*	*	*	*	*	*	B-4	16
C X1 F	BASE, SWIVEL: 8448626 (19204)	EA	1	B-4	17
P O	5315-058-6078	PIN, SPRING: TUBULAR SLOTTED, S, PHOS-CTD, 1/8 NOM DIA, 7/16 LG MS 16562-126 (96906)	EA	1	*	*	*	*	*	*	*	*	B-4	18
C P O	1005-017-9543	SWIVEL, GUN SLING: UPPER AND LOWER RECEIVER 8448571 (19204)	EA	1	REF	REF	REF	REF	REF	REF	REF	REF	B-4	19
X1 F	STOCK: 62204	EA	1	B-4	20
C P O	1005-992-6655	SPRING, DETENT, TAKE- DOWN PIN: 8448586 (19204)	EA	2	*	*	*	*	*	*	*	*	B-4	21

(1) Source Maint and Reev Code			(2) Federal stock No.	(3) Description Reference Number & Mfr Code Usable on Code	(4) Unit of meas	(5) Qty inc in unit	(6) 30-Day DS maint allowance			(7) 30-Day GS maint allowance			(8) 1-Yr alw per 100 equip enjncy	(9) Depot maint alw per 100 equip	(10) Illustration		
(a) Source	(b) Maint	(c) Reev					(a) 1-20	(b) 21-50	(c) 51-100	(a) 1-20	(b) 21-50	(c) 51-100			(a) Fig. No.	(b) Item No.	
LOWER RECEIVER GROUP—Continued																	
C	P	O	✓	1005-992-6654	DETENT, TAKEDOWN PIN: 8448585 (19204)	EA	2	*	*	*	*	*	*	*	*	B-4	22
✓	C	P	O	✓	1005-992-6653	PIN, TAKEDOWN: 8448584 (19204)	EA	1	*	*	*	*	*	*	*	B-4	23
✓	C	P	F	✓	1005-937-3078	BUFFER ASSEMBLY: LOWER RECEIVER 8448615 (19204)	EA	1	*	*	*	*	*	*	*	B-4	24
✓	C	P	F	✓	1005-992-6665	SPRING, ACTION: 8448629 (19204)	EA	1	*	*	*	*	*	*	*	B-4	25
C	P	F	✓	1005-992-7297	EXTENSION, LOWER RECEIVER: 8448581 (19204)	EA	1	*	*	*	*	*	*	*	*	B-4	26
C	P	F	✓	1005-992-6651	RETAINER, BUFFER: 8448582 (19204)	EA	1	*	*	*	*	*	*	*	*	B-4	27
C	P	F	✓	1005-992-6652	SPRING, BUFFER RETAINER: 8448583 (19204)	EA	1	*	*	*	*	*	*	*	*	B-4	28
C	P	F	✓	1005-992-7309	PIN, HAMMER AND TRIGGER: 8448609 (19204)	EA	2	*	*	*	*	*	*	*	*	B-4	29
C	P	F	✓	1005-017-9551	HAMMER ASSEMBLY: LOWER RECEIVER 8448612 (19204)	EA	1	*	*	*	*	*	*	*	*	B-4	30
C	P	F	✓	1005-992-6648	SPRING, HAMMER: 8448611 (19204)	EA	1	*	*	*	*	*	*	*	*	B-4	31
C	P	F	✓	1005-992-6650	PIN, AUTOMATIC SEAR: 8448599 (19204)	EA	1	*	*	*	*	*	*	*	*	B-4	32
C	P	F	✓	1005-992-6649	SEAR, AUTOMATIC: 8448595 (19204)	EA	1	*	*	*	*	*	*	*	*	B-4	33
C	P	F	✓	1005-992-6666	LEVER, SELECTOR: 8448630 (19204)	EA	1	*	*	*	*	*	*	*	*	B-4	34
C	P	F	✓	1005-999-0406	DISCONNECTOR: 8448635 (19204)	EA	1	*	*	*	*	*	*	*	*	B-4	35
C	P	F	✓	1005-992-7307	TRIGGER: 8448592 (19204)	EA	1	*	*	*	*	*	*	*	*	B-4	36
✓	C	P	F	✓	1005-992-7308	SPRING, TRIGGER: 8448593 (19204)	EA	1	*	*	*	*	*	*	*	B-4	37
C	P	F	✓	1005-992-7311	SPRING, DISCONNECTOR: 8448594 (19204)	EA	1	*	*	*	*	*	*	*	*	B-4	38
P	F	✓	✓	5315-812-3312	PIN, SPRING: TUBULAR, SLOTTED, S, PHOS-CTD, 3/32 NOM DIA, 1/2 LG MS 16562-119 (96906)	EA	1	*	*	*	*	*	*	*	*	B-4	39
C	P	F	✓	1005-017-9548	CATCH, BOLT: 8448628 (19204)	EA	1	*	*	*	*	*	*	*	*	B-4	40
C	P	F	✓	1005-056-2247	PLUNGER, BOLT CATCH: 8448634 (19204)	EA	1	*	*	*	*	*	*	*	*	B-4	41
C	P	F	✓	1005-056-2246	SPRING, BOLT CATCH: 8448633 (19204)	EA	1	*	*	*	*	*	*	*	*	B-4	42
C	P	F	✓	1005-056-2201	CATCH, MAGAZINE: 8448638 (19204)	EA	1	*	*	*	*	*	*	*	*	B-4	43
C	P	F	✓	1005-992-7302	BUTTON, MAGAZINE CATCH: 8448636 (19204)	EA	1	*	*	*	*	*	*	*	*	B-4	44
C	P	F	✓	1005-992-7301	SPRING, MAGAZINE CATCH: 8448637 (19204)	EA	1	*	*	*	*	*	*	*	*	B-4	45
P	F	✓	✓	5315-058-6081	PIN, SPRING: TUBULAR, SLOTTED, S, PHOS-CTD, 1/8 NOM DIA, 5/8 LG MS 16562-129 (96906)	EA	1	*	*	*	*	*	*	*	*	B-4	46

Section II. REPAIR PARTS LIST—Continued

TM 9-1005-249-34

(1) Source Maint and Recov Code			(2) Federal stock No.	(3) Description Reference Number & Mfr Code Usable on Code	(4) Unit of meas	(5) Qty inc in unit	(6) 30-Day DS maint allowance			(7) 30-Day GS maint allowance			(8) 1-Yr alw per 100 equip century	(9) Depot maint alw per 100 equip	(10) Illustration	
(a) Source	(b) Maint	(c) Recov					(a) 1-20	(b) 21-50	(c) 51-100	(a) 1-20	(b) 21-50	(c) 51-100			(a) Fig. No.	(b) Item No.
C	P	F	1005-992-7299	LOWER RECEIVER GROUP— Continued GUARD, TRIGGER: 8448587 (19204)	EA	1	*	*	*	*	*	*	*	*	B-4	47
C	P	O	1005-017-9537	PIN, PIVOT: LOWER RECEIVER 8448621 (19204)	EA	1	*	*	*	*	*	*	*	*	B-4	48
C	X1	F	RECEIVER, LOWER: 8448608 (19204)		1	B-4	49
P	O		1005-050-6357	SMALL ARMS CLEANING ROD, M11E3 ROD SECTION, CLEANING, SMALL ARMS: 8436775 (19204)	EA		*	*	*	*	*	*	*	...	B-5	7
P	O		1005-937-2250	SWAB HOLDER SECTION, SMALL ARMS CLEANING ROD: 11686327 (19205)	EA		*	*	*	*	*	*	*	...	B-5	6

Section III. SPECIAL TOOLS LIST

(1) Source Maint and Recov Code			(2) Federal stock No.	(3) Description Reference Number & Mfr Code Usable on Code	(4) Unit of meas	(5) Qty inc in unit	(6) 30-Day DS maint allowance			(7) 30-Day GS maint allowance			(8) 1-Yr alw. per 100 equip centage	(9) Depot maint alw per 100 equip	(10) Illustration	
(a) Source	(b) Maint	(c) Recov					(a) 1-20	(b) 21-50	(c) 51-100	(a) 1-20	(b) 21-50	(c) 51-100			(a) Fig. No.	(b) Item No.
P	C		1005-089-3994	TOOLS AND EQUIPMENT AUTHORIZED FOR UNIT REPLACEMENT ROD, CLEANING, SMALL ARMS: M11E3 8436777 (19204)	EA	...	*	*	*	*	*	*	*	...	B-5	5
P	O		1005-193-8306	BAG, PROTECTIVE, CAR- TRIDGE MAGAZINE: (500 PER BOX) (FOR 30 RD MAG- AZINE) 8448464 (19204)	BX	...	*	*	*	*	*	*	*	...	B-6	2
P	O		1005-242-5687	BOTTLE ASSEMBLY, CYLIN- DRICAL: (0.5 OZ CAP.) FOR SEMI-FLUID LUBRICATING OIL 8448444 (19204)	EA	...	*	*	*	*	*	*	*	...	B-5	3
P	C		1005-403-5804	CASE, SMALL ARMS ACCESSORIES: 8448751 (19204)	EA	...	*	*	*	*	*	*	*	...	B-5	8
P	C		1005-494-6602	BRUSH, CLEANING, SMALL ARMS: 8448462 (19204)	EA	...	*	*	*	*	*	*	*	...	B-5	4
P	C		1005-654-4058	SLING, SMALL ARMS: M1, WEBBING 6544058 (19204)	EA	...	*	*	*	*	*	*	*	...	B-5	9
P	C		1005-903-1296	BRUSH, CLEANING, SMALL ARMS: BORE 11686340 (19204)	EA	...	*	*	*	*	*	*	*	...	B-5	1
P	O		1005-912-4248	SWAB, SMALL ARMS CLEAN- ING: 5.56-MM (1000 PER PACKAGE) 11686408 (19205)	PG	...	*	*	*	*	*	*	*	...	B-6	3
P	O		1005-992-6676	BIPOD, RIFLE: M3 8448457 (19204)	EA	...	*	*	*	*	*	*	*	...	1-3	1
P	C		1005-999-1435	BRUSH, CLEANING, SMALL ARMS: CHAMBER 8432358 (19204)	EA	...	*	*	*	*	*	*	*	...	B-5	2
P	O		1005-999-2430	CASE, CARRYING: BIPOD AND CLEANING EQUIPMENT 2-2-246 (19204)	EA	...	*	*	*	*	*	*	*	...	1-3	2
P	O		5340-880-7666	CAP, PROTECTIVE, DUST AND MOISTURE SEAL: MUZZLE 8445067 (19204)	EA	...	*	*	*	*	*	*	*	...	B-6	1
P	C		8465-781-9564	CASE, MAINTENANCE EQUIP- MENT SMALL ARMS: 2-2-282 (81337) ARTIC USE ONLY	EA	...	*	*	*	*	*	*	*	...	B-15
P	O		1005-791-3377	CASE, LUBRICANT: 7790995 (19204) SPECIAL AUTHORIZATION OF UNIT COMMANDER	EA	...	*	*	*	*	*	*	*	...	B-7	2
P	O		1005-714-9749	SLING, SMALL ARMS: 7149749 (19204)	EA	...	*	*	*	*	*	*	*	...	B-7	1

Section III. SPECIAL TOOLS LIST—Continued

TM 9-2005-249-34

(1) Source Maint and Repair Code			(2) Federal stock No.	(3) Description Reference Number & Mfr Code Usable on Code	(4) Unit of meas	(5) Qty Inc in unit	(6) 30-Day DS maint allowance			(7) 30-Day GS maint allowance			(8) 1-Yr alw per 100 equip enclty	(9) Depot maint alw per 100 equip	(10) Illustration	
(a) Source	(b) Maint	(c) Repair					(a) 1-20	(b) 21-50	(c) 51-100	(a) 1-20	(b) 21-50	(c) 51-100			(a) Fig. No.	(b) Item No.
P	F	R	4933-775-0366	<p>SPECIAL TOOLS AND EQUIPMENT THE FOLLOWING BASIC SMALL ARMS DIRECT AND GENERAL SUPPORT MAINTENANCE TOOL SET IS AUTHORIZED, AS REQUIRED, TO ALL MAINTENANCE SUPPORT UNITS WITH A SMALL ARMS REPAIR MISSION TOOL SET, DIRECT AND GENERAL SUPPORT MAINTENANCE BASIC SMALL ARMS: 8426358 (19204)</p> <p>NOTE SEE SC 4933-95-CL-E04 FOR COMPONENTS</p> <p>THE FOLLOWING TOOL SETS ARE REQUISITIONED AND ISSUED TO MAINTENANCE UNITS PERFORMING DIRECT AND GENERAL SUPPORT MAINTENANCE. THE COMPLETE SET WILL BE REQUISITIONED AND INDIVIDUAL TOOLS LISTED BELOW MAY ALSO BE REQUISITIONED UNDER THEIR OWN STOCK NUMBER FOR REPLACEMENT PURPOSES.</p>	EA	...	*	*	*	*	*	*				
P	F	R	4933-056-7106	<p>TOOL SET, DIRECT AND GENERAL SUPPORT MAINTENANCE: 8426685 (19204)</p> <p>COMPOSED OF:</p>	SE	...	*	*	*	*	*	*				
			4933-070-7814	<p>1-GAGE, HEADSPACE: 7799734 (19204)</p>	EA	...	*	*	*	*	*	*			B-8	
			4933-070-7815	<p>1-GAGE, FIRING PIN PROTRUSION: 7799735 (19204)</p>	EA	...	*	*	*	*	*	*			B-9	
			4933-070-9151	<p>1-FIXTURE, BARREL REMOVER: VISE JAWS 11010032 (19204)</p>	EA	...	*	*	*	*	*	*			B-10	
			4933-070-9152	<p>1-WRENCH, COMBINATION: BARREL NUT AND FLASH SUPPRESSOR 11010033 (19204)</p>	EA	...	*	*	*	*	*	*			B-11	
			4933-912-3409	<p>1-GAGE BARREL EROSION: 7799792 (19204)</p>	EA	...	*	*	*	*	*	*			B-12	
			4933-221-9391	<p>1-GAGE, STRAIGHTNESS: BARREL BORE 8448202 (19205)</p>	EA	...	*	*	*	*	*	*			B-14	
			4933-944-7084	<p>1-CASE, CARRYING, GAGE, BARREL: 7799809 (19204)</p>	EA	...	*	*	*	*	*	*			B-13	1
			4933-800-7508	<p>1-REFLECTOR TOOL CHAMBER: 8448201 (19204)</p>	EA	...	*	*	*	*	*	*			B-13	2

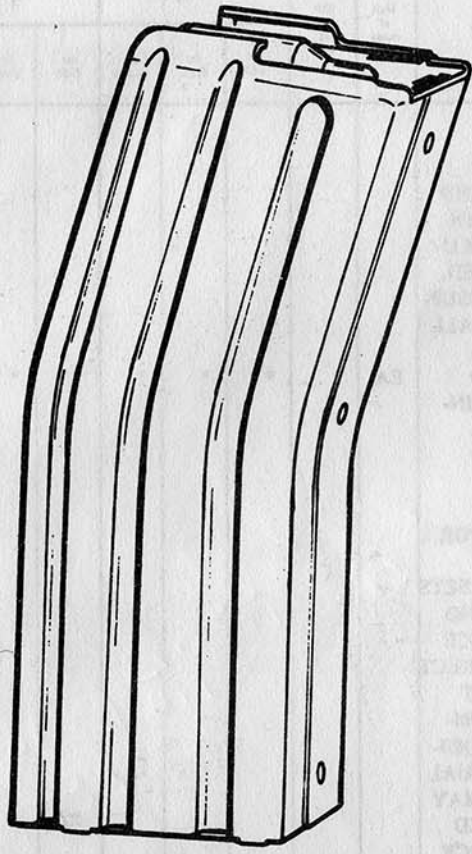

WE 69284

Figure B-1. Magazine assembly.

WE 69765

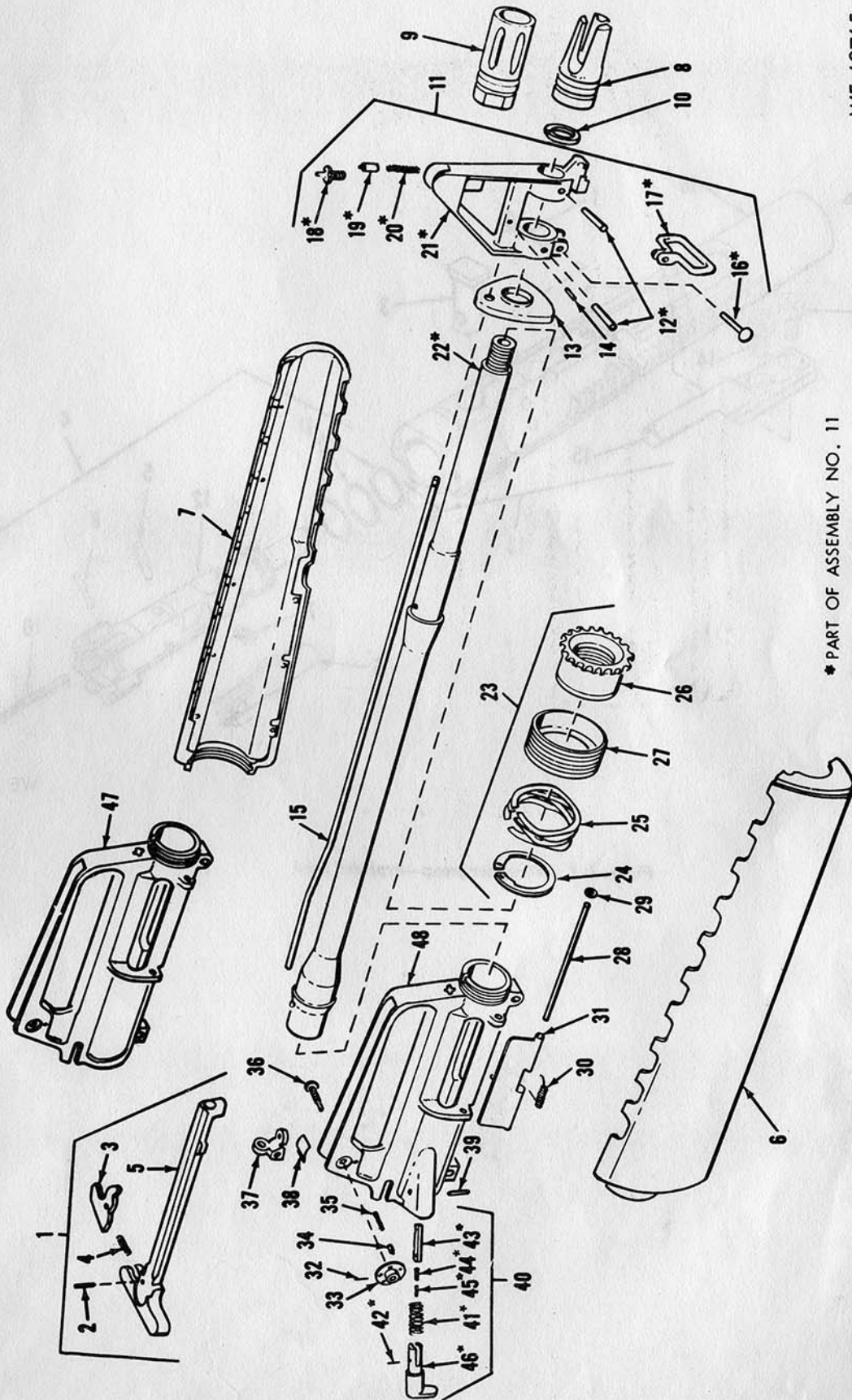

* PART OF ASSEMBLY NO. 11
 • PART OF ASSEMBLY NO. 40

Figure B-2. Upper receiver group—exploded view.

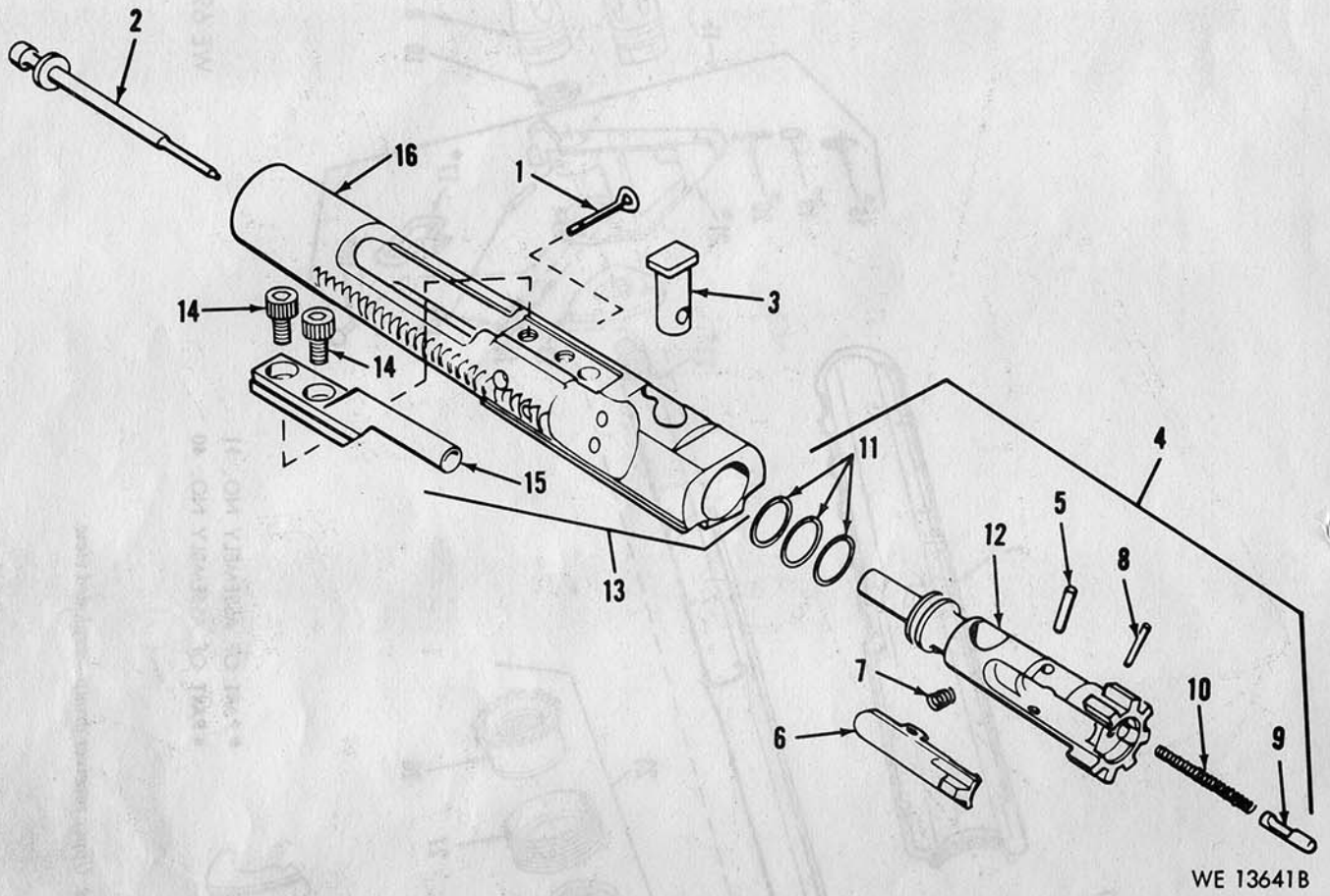
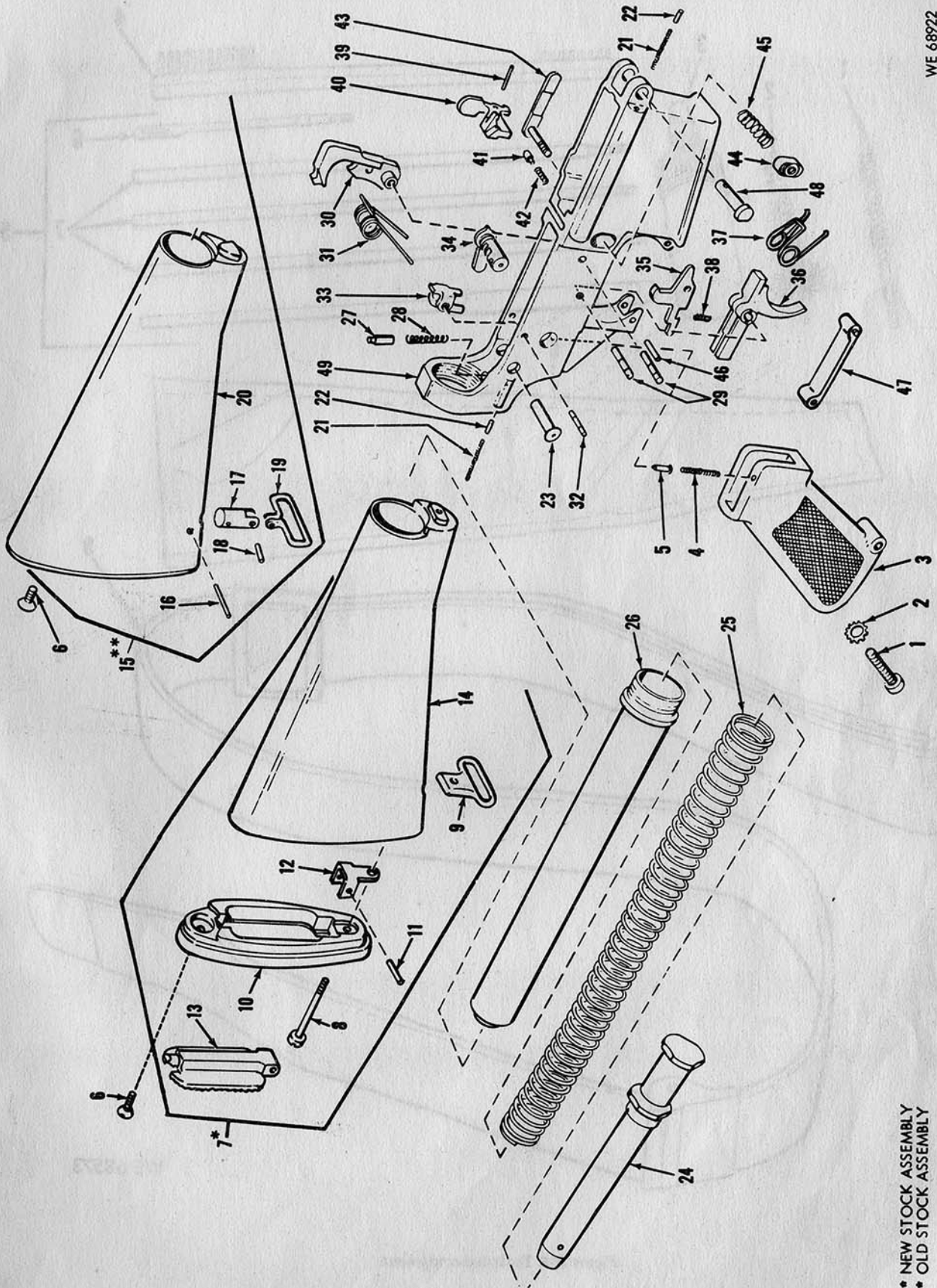

Figure B-3. Bolt carrier group—exploded view.

WE 68922



* NEW STOCK ASSEMBLY
 ** OLD STOCK ASSEMBLY

Figure B-4. Lower receiver group—exploded view.

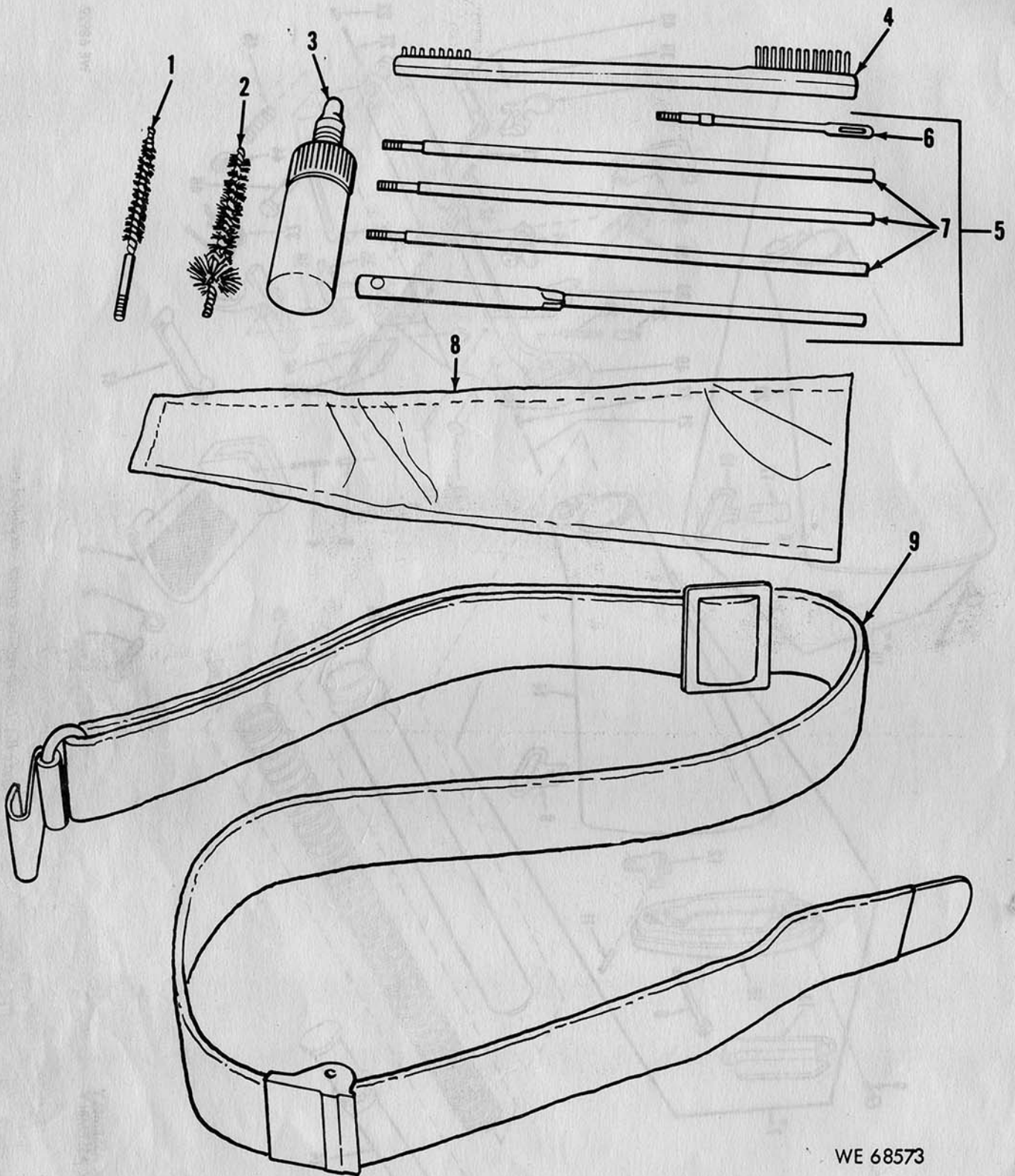

WE 68573

Figure B-5. Tools and equipment.

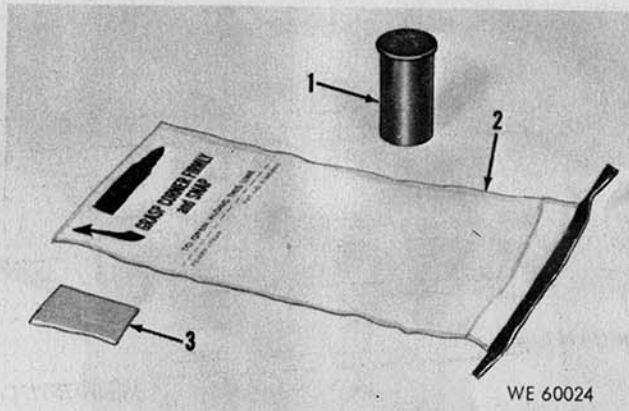

Figure B-6. Tools and equipment.

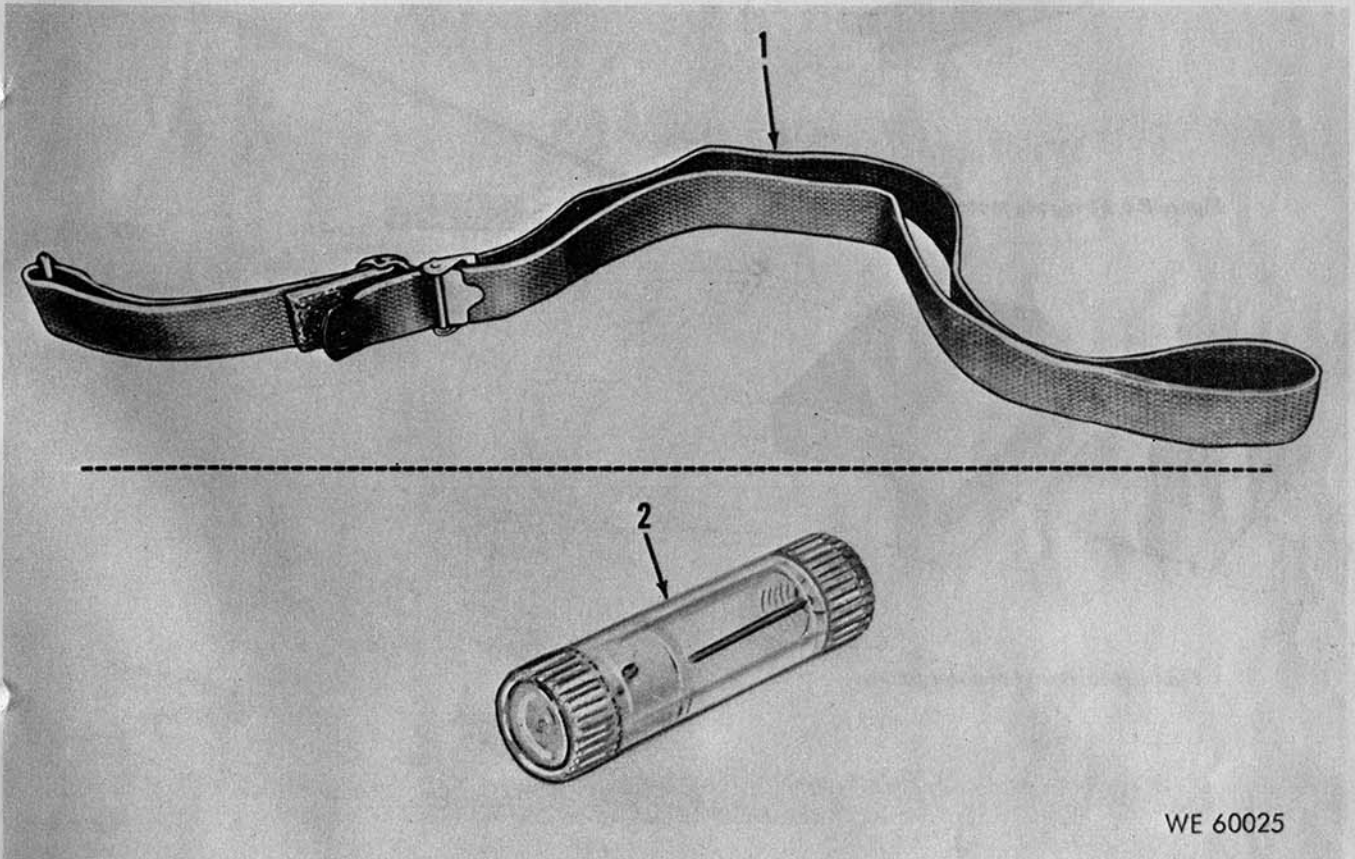
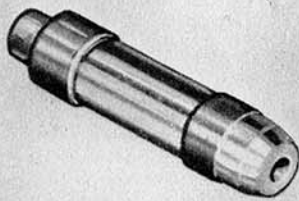
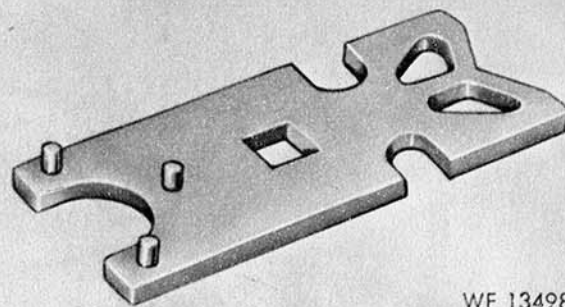

Figure B-7. Tools and equipment.



WE 13501

Figure B-8. Headspace gage (field type).



WE 13498

Figure B-11. Combination wrench.

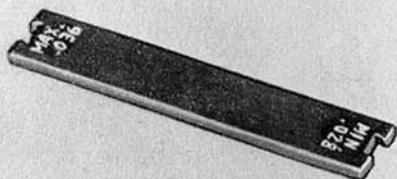

WE 13500

Figure B-9. Firing pin protrusion gage.

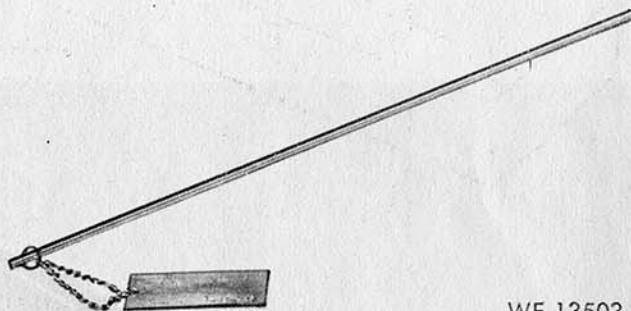

WE 13503

Figure B-12. Barrel erosion gage.

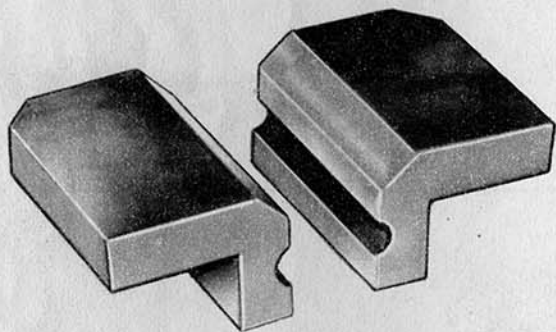

WE 13499

Figure B-10. Barrel remover fixture.

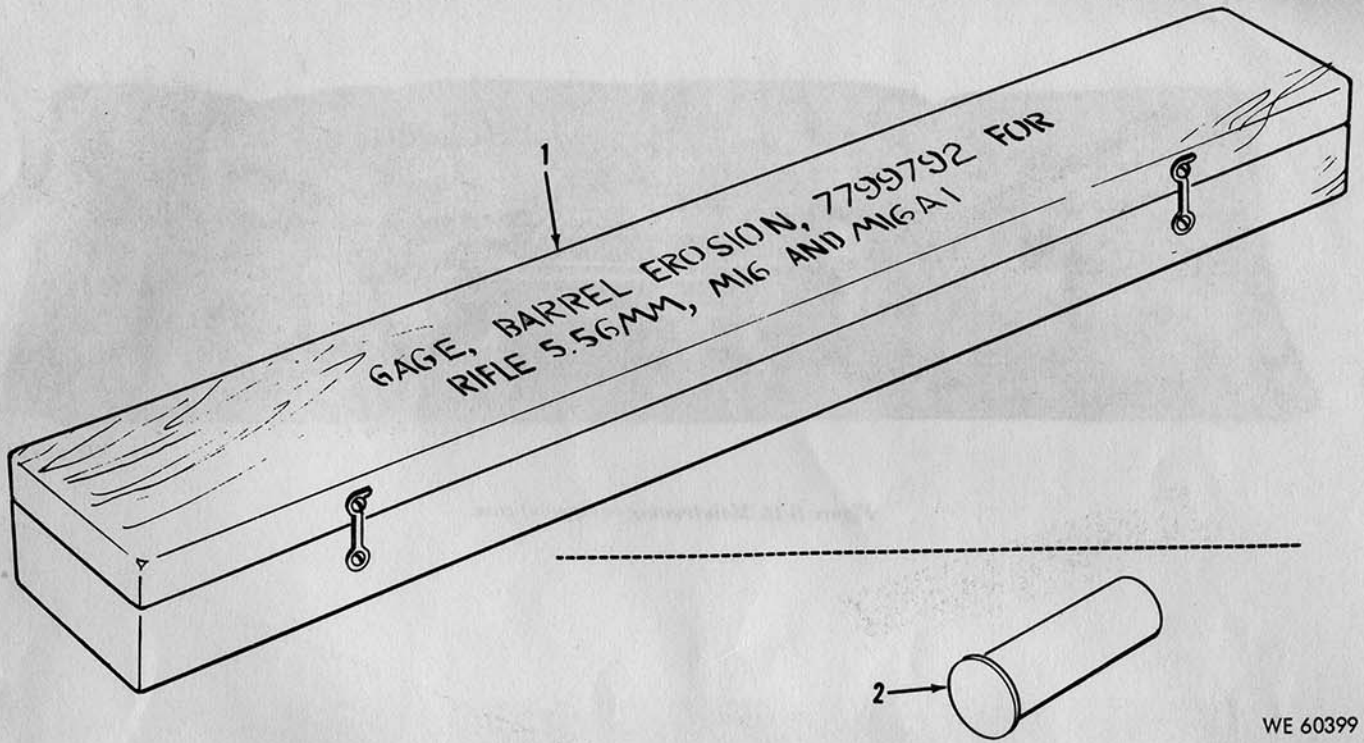

WE 60399

Figure B-13. Tools and equipment.

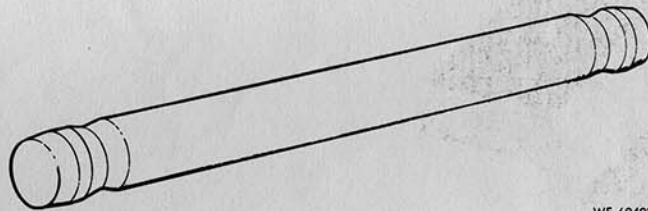

WE 69493

Figure B-14. Straightness gage.

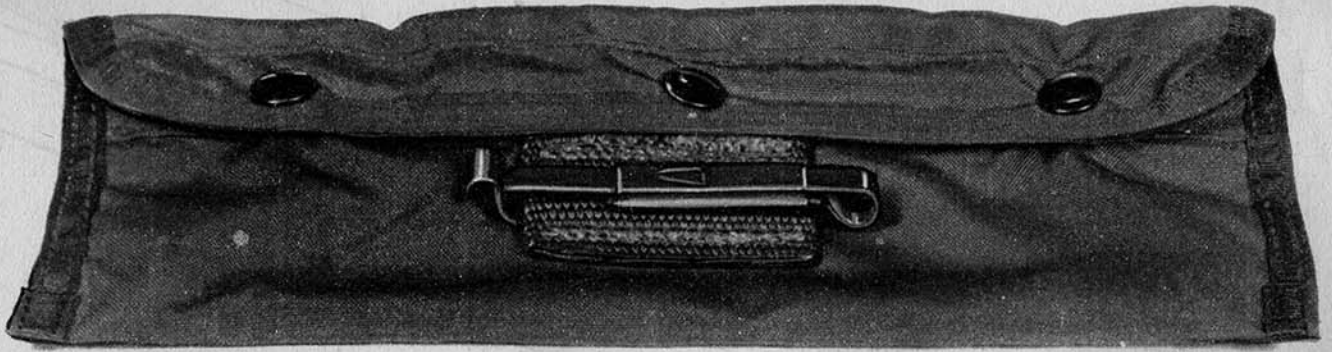

WE 68923

Figure B-15. Maintenance equipment case.

Section IV. FEDERAL STOCK NUMBER AND REFERENCE NUMBER INDEX

Stock Number	Figure No.	Item No.	Stock Number	Figure No.	Item No.
1005-017-9537	B-4	48	1005-979-3930	B-2	18
1005-017-9538	B-2	45	1005-979-3931	B-2	19
1005-017-9539	B-2	42	1005-992-6648	B-4	31
1005-017-9540	B-2	43	1005-992-6649	B-4	33
1005-017-9541	B-2	40	1005-992-6650	B-4	32
1005-017-9542	B-2	47	1005-992-6651	B-4	27
1005-017-9543	B-2	16	1005-992-6652	B-4	28
	B-4	19	1005-992-6653	B-4	23
1005-017-9546	B-2	1	1005-992-6654	B-4	22
1005-017-9547	B-3	2	1005-992-6655	B-4	21
1005-017-9548	B-4	40	1005-992-6657	B-4	6
1005-017-9549	B-4	15	1005-992-6665	B-4	25
1005-017-9550	B-2	46	1005-992-6666	B-4	34
1005-017-9551	B-4	30	1005-992-6667	B-4	5
1005-050-6357	B-5	7	1005-992-6676	1-3	1
1005-056-2201	B-4	43	1005-992-7280	B-2	9
1005-056-2246	B-4	42	1005-992-7283	B-3	15
1005-056-2247	B-4	41	1005-992-7284	B-3	14
1005-056-2250	B-4	3	1005-992-7285	B-3	4
1005-056-2251	B-2	7	1005-992-7287	B-3	11
1005-056-2252	B-2	6	1005-992-7288	B-3	6
1005-089-3994	B-5	5	1005-992-7289	B-3	7
1005-152-3441	B-2	10	1005-992-7290	B-3	5
1005-193-8306	B-6	2	1005-992-7291	B-3	9
1005-242-5687	B-5	3	1005-992-7292	B-3	10
1005-403-0962	B-4	13		B-4	4
1005-403-0963	B-4	10	1005-992-7294	B-3	3
1005-403-0964	B-4	9	1005-992-7297	B-4	26
1005-403-5804	B-5	8	1005-992-7299	B-4	47
1005-489-0369	B-4	7	1005-992-7301	B-4	45
1005-494-6602	B-5	4	1005-992-7302	B-4	44
1005-523-8084	B-2	44	1005-992-7307	B-4	36
1005-654-4058	B-5	9	1005-992-7308	B-4	37
1005-714-9749	B-7	1	1005-992-7309	B-4	29
1005-738-6213	B-3	16	1005-992-7311	B-4	38
1005-791-3377	B-7	2	1005-999-0404	B-2	4
1005-903-1296	B-5	1	1005-999-0405	B-2	3
1005-912-4248	B-6	3	1005-999-0406	B-4	35
1005-921-5004	B-1		1005-999-1435	B-5	2
1005-933-8089	B-2	8	1005-999-2430	1-3	2
1005-937-2250	B-5	6	4933-070-7814	B-8	—
1005-937-3078	B-4	24	4933-070-7815	B-9	—
1005-978-1022	B-2	30	4933-070-9151	B-10	—
1005-978-1023	B-2	27	4933-070-9152	B-11	—
1005-978-1025	B-2	29	4933-221-9391	B-14	—
1005-978-1026	B-2	36	4933-800-7508	B-13	2
1005-978-1027	B-2	37	4933-912-3409	B-12	—
1005-978-1028	B-2	35	4933-944-7084	B-13	1
1005-978-1029	B-2	32	5305-463-3893	B-4	8
1005-978-1030	B-2	33	5305-912-7296	B-4	1
1005-978-1032	B-2	34	5310-527-3634	B-4	2
1005-978-1034	B-2	25	5315-058-6044	B-2	13
1005-978-1035	B-2	26	5315-058-6078	B-4	18
1005-978-1036	B-2	24	5315-058-6081	B-4	46
1005-978-1038	B-2	14	5315-282-3642	B-2	2
1005-979-3924	B-2	12		B-2	31
1005-979-3926	B-2	11		B-2	41
1005-979-3929	B-2	17	5315-463-3894	B-4	11

Section IV. FEDERAL STOCK NUMBER AND REFERENCE NUMBER INDEX (Continued)

Stock Number	Figure No.	Item No.	Reference No.	Mfg. Code	Fig. No.	Item No.	
5315-514-2358	B-3	8	8448507	19204	B-3	16	
5315-812-3312	B-4	39	8448508	19204	B-3	14	
5315-840-3812	B-2	38	8448509	19204	B-3	4	
5315-898-9823	B-4	16	8448510	19204	B-3	12	
5315-999-1509	B-3	1	8448511	19204	B-3	11	
5320-055-3066	B-2	16	8448512	19204	B-3	6	
5340-463-3892	B-4	12	8448513	19204	B-3	5	
5340-880-7666	B-6	1	8448514	19204	B-3	7	
5365-999-0863	B-2	23	8448515	19204	B-3	9	
5340-999-0864	B-2	28	8448516	19204	B-3	10	
8465-781-9564	B-15				B-4	4	
			8448517	19204	B-2	1	
			8448518	19204	B-2	5	
			8448519	19204	B-2	3	
MS 16535-125	96906	B-2	16	8448520	19204	B-2	4
MS 16562-96	96906	B-2	2	8448524	19204	B-2	47
		B-2	31	8448525	19204	B-2	30
		B-2	41	8448532	19204	B-2	29
MS 16562-99	96906	B-3	8	8448533	19204	B-2	27
MS 16562-106	96906	B-2	13	8448534	19204	B-2	35
MS 16562-119	96906	B-4	39	8448535	19204	B-2	32
MS 16562-121	96906	B-2	38	8448536	19204	B-2	37
MS 16562-126	96906	B-4	18	8448537	19204	B-2	33
MS 16562-129	96906	B-4	46	8448538	19204	B-2	34
MS 16562-131	96906	B-4	16	8448539	19204	B-2	36
MS 16632-3012	96906	B-2	28	8448540	19204	B-2	40
MS 35276-284	96906	B-4	1	8448541	19204	B-2	39
MS 35335-61	96906	B-4	2	8448542	19204	B-2	44
11010032	19204	B-10		8448543	19204	B-2	42
11010033	19204	B-11		8448544	19204	B-2	43
11686327	19205	B-5	6	8448545	19204	B-2	45
11686340	19204	B-5	1	8448548	19204	B-2	21
11686408	19205	B-6	3	8448553	19204	B-2	25
2-2-246	19204	1-3	2	8448554	19204	B-2	26
2-2-282	81337	B-15		8448555	19204	B-2	24
62113		B-2	22	8448557	19204	B-2	7
62204		B-4	20	8448561	19204	B-2	6
6544058	19204	B-5	9	8448564	19204	B-2	12
7149749	19204	B-7	1	8448566	19204	B-2	20
7790995	19204	B-7	2	8448567	19204	B-2	14
7799734	19204	B-8		8448571	19204	B-2	16
7799735	19204	B-9				B-4	19
7799792	19204	B-12		8448572	19204	B-2	17
7799809	19204	B-13	1	8448573	19204	B-2	18
8432358	19204	B-5	2	8448574	19204	B-2	19
8436775	19204	B-5	7	8448575	19204	B-2	11
8436777	19204	B-5	5	8448576	19204	B-2	8
8445067	19204	B-6	1	8448577	19204	B-2	9
8448201	19204	B-13	2	8448581	19204	B-4	26
8448202	19205	B-14		8448582	19204	B-4	27
8448444	19204	B-5	3	8448583	19204	B-4	28
8448457	19204	1-3	1	8448584	19204	B-4	23
8448462	19204	B-5	4	8448585	19204	B-4	22
8448464	19204	B-6	2	8448586	19204	B-4	21
8448502	19204	B-3	3	8448587	19204	B-4	47
8448503	19204	B-3	2	8448592	19204	B-4	36
8448504	19204	B-3	1	8448593	19204	B-4	37
8448505	19204	B-3	13	8448594	19204	B-4	38
8448506	19204	B-3	15	8448595	19204	B-4	33

Section IV. FEDERAL STOCK NUMBER AND REFERENCE NUMBER INDEX (Continued)

Reference No.	Mfg. Code	Fig. No.	Item No.	Reference No.	Mfg. Code	Fig. No.	Item No.
8448599	19204	B-4	32	8448634	19204	B-4	41
8448603	19204	B-2	46	8448635	19204	B-4	35
8448608	19204	B-4	49	8448636	19204	B-4	44
8448609	19204	B-4	29	8448637	19204	B-4	45
8448611	19204	B-4	31	8448638	19204	B-4	43
8448612	19204	B-4	30	8448650	19204	B-4	7
8448615	19204	B-4	24	8448651	19204	B-4	14
8448621	19204	B-4	48	8448652	19204	B-4	9
8448622	19204	B-4	15	8448653	19204	B-4	12
8448626	19204	B-4	17	8448654	19204	B-4	8
8448627	19204	B-4	6	8448655	19204	B-4	11
8448628	19204	B-4	40	8448656	19204	B-4	10
8448629	19204	B-4	25	8448658	19204	B-4	13
8448630	19204	B-4	34	8448663	19204	B-2	10
8448631	19204	B-4	5	8448665	19204	B-2	23
8448632	19204	B-4	3	8448670	19204	B-1	
8448633	19204	B-4	42	8448751	19204	B-5	8

By Order of the Secretary of the Army:

W. C. WESTMORELAND,
General, United States Army,
Chief of Staff.

Official:

VERNE L. BOWERS,
Major General, United States Army,
The Adjutant General.

Distribution:

To be distributed in accordance with DA Form 12-40, (qty rqr block no. 137) Direct and General Support maintenance requirements for Rifle, 5.56-MM, M16 and M16A1.

☆ U. S. GOVERNMENT PRINTING OFFICE: 1972-754-103/81

DEPARTMENT OF THE ARMY
US ARMY AG PUBLICATIONS CENTER
1655 WOODSON ROAD
ST. LOUIS, MISSOURI 63114

OFFICIAL BUSINESS
PENALTY FOR PRIVATE USE, \$300

POSTAGE AND FEES PAID
DEPARTMENT OF THE ARMY
DOD 314

