

**TECHNICAL MANUAL
OPERATOR'S AND
ORGANIZATIONAL MAINTENANCE MANUAL
INCLUDING REPAIR PARTS AND
SPECIAL TOOLS LIST
CONVERSION KIT
(CALIBER .22 RIMFIRE ADAPTER) M261
(NSN 1005-01-010-1561)
FOR
RIFLE, 5.56-MM, M16 AND M16A1**

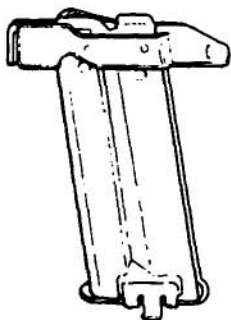
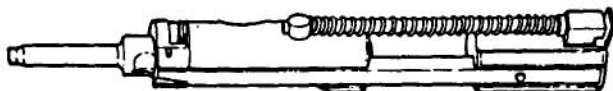

EQUIPMENT DESCRIPTION	1-1
PERFORMANCE DATA	1-1
OPERATING INSTRUCTIONS	2-1
PREVENTIVE MAINTENANCE CHECKS AND SERVICES (PMCS)	2-6
OPERATION UNDER UNUSUAL CONDITIONS	2-8
IDENTIFICATION AND MARKING OF AMMUNITION	2-8
CARE, HANDLING AND PRESERVATION OF AMMUNITION	2-8
OPERATOR MAINTENANCE	3-1
OPERATOR LUBRICATION INSTRUCTIONS	3-1
OPERATOR TROUBLESHOOTING	3-1
ORGANIZATIONAL MAINTENANCE	4-1
SERVICE UPON RECEIPT OF MATERIEL	4-1
ORGANIZATIONAL LUBRICATION INSTRUCTIONS	4-1
ORGANIZATIONAL TROUBLESHOOTING	4-2
REFERENCES	A-1
COMPONENTS OF END ITEM LIST	B-1
MAINTENANCE ALLOCATION CHART	C-1
REPAIR PARTS AND SPECIAL TOOLS LIST	D-1
ADDITIONAL AUTHORIZATION LIST	E-1
EXPENDABLE SUPPLIES AND MAERIALS LIST	F-1

**HEADQUARTERS, DEPARTMENT OF THE ARMY
SEPTEMBER 1980**

This copy is a reprint which includes current pages from Changes 1 and 2.

WARNING

Before installing conversion kit, be sure to clear rifle (TM 9-1005-249-10) and position selector lever on SAFE.

WARNING

Do not load more than 10 cartridges in the magazine adapter assembly.

WARNING

Do not fire corroded ammunition, dented cartridges with loose bullets, or cartridges exposed to extreme heat (135°F (57°C)) until they have cooled.

Do not lubricate cartridges. A buildup of oil or grease may collect in the weapon and create excessive and dangerous chamber pressure when fired.

WARNING

The magazine adapter is under spring tension. Be careful and don't let it get away from you. It could be dangerous.

WARNING

Do not load ammunition into the bolt adapter or snap the adapter bolt forward when the adapter is not installed in the rifle.

CHANGE }
No. 2 }

HEADQUARTERS
DEPARTMENT OF THE ARMY
Washington, DC, 21 August 1984

**Operator's and Organizational Maintenance Manual
Including Repair Parts and Special Tools List**

**CONVERSION KIT (CALIBER .22 RIMFIRE ADAPTER) M261
(NSN 1005-01-010-1561)
FOR
RIFLE, 5.56-MM, M16 and M16A1**

TM 9-6920-363-12&P, 29 September 1980, is changed as follows:

1. Remove old pages and insert new pages as indicated below. New or changed material is indicated by a vertical bar in the margin of the page.

Remove Pages

None
i through iii
1-1 (1-2 Blank)
2-3 through 2-8
3-1 and 3-2
4-3 and 4-4
4-7 and 4-8
B-1 and B-2
C-3 (C-4 Blank)
D-3 through D-7 (D-8 Blank)
F-1 and F-2

Insert Pages

a (b Blank)
i through iii
1-1 (1-2 Blank)
2-3 through 2-8
3-1 and 3-2
4-3 and 4-4
4-7 and 4-8
B-1 and B-2
C-3 (C-4 Blank)
D-3 through D-8
F-1 and F-2

2. File this sheet and previous change sheets in the back of the publication for reference purposes.

By Order of the Secretary of the Army:

Official:

ROBERT M. JOYCE
Major General, United States Army
The Adjutant General

JOHN A. WICKHAM, JR.
General, United States Army
Chief of Staff

Distribution:

To be distributed in accordance with DA Form 12-40, Organizational Maintenance requirements for Rifle, 5.56MM, M16, M16A1.

CHANGE }
No. 1 }

HEADQUARTERS
DEPARTMENT OF THE ARMY
Washington, DC ,27 June 1983

**Operator's and Organizational Maintenance Manual
Including Repair Parts and Special Tools List**

**CONVERSION KIT (CALIBER .22 RIMFIRE ADAPTER) M261
(NSN 1005-01-010-1561)
FOR
RIFLE, 5.56-MM, M16 and M16A1**

TM 9-6920-363-12&P, 29 September 1980, is changed as follows:

1. Remove old pages and insert -new pages as indicated below. New or changed material is indicated by a vertical bar in the margin of the page.

<i>Remove Pages</i>	<i>Inset Pages</i>
i and ii	i and ii
2-7 and 2-8	2-7 and 2-8
None	2-9 (2-10 Blank)
3-1 and 3-2	3-1 and 3-2
3-7 and 3-8	3-7 and 3-8
4-7 and 4-8	4-7 and 4-8
F-1 and F-2	F-1 and F-2

2. File this change sheet in front of the publication for reference purposes.

By Order of the Secretary of the Army:

E. C. MEYER
General, United States Army

Official: *Chief of Staff*

ROBERT M. JOYCE
Major General, United States Army
The Adjutant General

Distribution :

To be distributed in accordance with DA Form 12-40, Organizational Maintenance requirements for Rifle, 5.56-MM, M16 and M16A1.

WARNING

Dry Cleaning Solvent (SD) is flammable and toxic. Use it only in a well ventilated area. The use of rubber gloves is necessary when washing the rimfire adapter to protect the skin.

WARNING

Safety goggles are required for all shooters and other personnel in close proximity to the shooter. A rimfire brass deflector installed on the rifle is also required. These items will help prevent possible eye damage due to malfunctions that can occur.

WARNING

Positioning the cartridge retainer on the bolt face properly is vital for safe conversion kit performance. A damaged or improperly positioned cartridge retainer will cause a cartridge to fire out of battery, possibly causing injury to the shooter and bystanders, or resulting in a high malfunction rate.

**Operator's and Organizational Maintenance Manual
Including Repair Parts and Special Tools List**

**CONVERSION KIT (CALIBER .22 RIMFIRE ADAPTER) M261
(NSN 1005-01-010-1561)
FOR
RIFLE, 5.56-MM, M16 AND M16A1**

Current as of 30 May 1984

REPORTING ERRORS AND RECOMMENDING IMPROVEMENTS

You can help improve this manual. If you find any mistakes or if you know of a way to improve the procedures, please let us know. Mail your letter, DA Form 2028 (Recommended Changes to Publications and Blank Forms), or DA Form 2028-2 located in the back of this manual direct to: Commander, US Army Armament, Munitions and Chemical Command, ATTN: DRSMC-MAS (R), Rock Island, IL 61299. A reply will be furnished to you.

		Paragraph	Page
CHAPTER	1. INTRODUCTION		1-1
Section	I. General Information		1-1
	Scope	1-1	1-1
	Maintenance Forms and Records	1-2	1-1
	Administrative Storage.....	1-3	1-1
	Reporting Equipment Improvement Recommendations (EIR)	1-4	1-1
	Hand Receipt	1-5	1-1
	II. Equipment Description and Data		1-1
	Description	1-6	1-1
	Performance Data	1-7	1-1
CHAPTER	2. OPERATING INSTRUCTIONS		2-1
Section	I. Operating Instructions		2-1
	General	2-1	2-1
	Installation of Bolt Adapter Assembly	2-2	2-1
	Installation of Magazine Adapter Assembly	2-3	2-3
	Installation of Rimfire Brass Deflector	2-3.1	2-6
	II. Preventive Maintenance Checks and Services (PMCS)		2-6.2
	General.....	2-4	2-6.2

*This manual supersedes TM 9-6920-363-12&P, 15 March 1978.

	Paragraph	Page
Section III. Operation Under Unusual Conditions		2-8
General	2-5	2-8
IV. Ammunition		2-8
General	2-6	2-8
Identification and Markings	2-7	2-9
Care, Handling, and Preservation.....	2-8	2-9
CHAPTER 3. OPERATOR MAINTENANCE INSTRUCTIONS		3-1
Section I. Lubrication Instructions.....		3-1
General	3-1	3-1
Bolt Adapter Assembly	3-2	3-1
Magazine Adapter Assembly	3-3	3-1
II. Troubleshooting		3-1
General	3-4	3-1
III. Maintenance of Conversion Kit		3-4
General	3-5	3-4
Bolt Adapter Assembly	3-6	3-4
Magazine Adapter Assembly	3-7	3-7
CHAPTER 4. ORGANIZATIONAL MAINTENANCE INSTRUCTIONS		4-1
Section I. Service Upon Receipt of Materiel		4-1
General	4-1	4-1
Service Upon Receipt of Materiel	4-2	4-1
II. Lubrication Instructions.....		4-1
General	4-3	4-1
Expendable and Consumable Supplies	4-4	4-1
Lubrication of Bolt Adapter Assembly	4-5	4-1
III. Preventive Maintenance Checks and Services		4-1
General	4-6	4-1
IV. Troubleshooting		4-2
General	4-7	4-2
V. Organizational Maintenance Instructions		4-4
Bolt Adapter Assembly	4-8	4-4

	Page	Illus * Fig
APPENDIX A. REFERENCES	A-1	
APPENDIX B. COMPONENTS OF END ITEM LIST	B-1	
Section I. Introduction	B-1	
II. Integral Components of the End Item	B-2	
III. Basic Issue Items	B-2	
APPENDIX C. MAINTENANCE ALLOCATION CHART	C-1	
Section I. Introduction	C-1	
II. Maintenance Allocation Chart	C-3	
III. Tool and Test Equipment Requirements	C-3	
IV. Remarks	C-3	
APPENDIX D. OPERATOR AND ORGANIZATIONAL MAINTENANCE REPAIR PARTS AND SPECIAL TOOLS LIST	D-1	
Section I. Introduction	D-1	
II. Repair Parts List	D-5	
Group 00 Conversion Kit 12003060	D-5	D-1
01 Bolt Adapter Assembly 12003080	D-6	D-2
Section III. Special Tools List	D-7	
IV. National Stock Number and Part Number Index	D-7	
APPENDIX E. ADDITIONAL AUTHORIZATION LIST	E-1	
Section I. Introduction	E-1	
II. Additional Authorization List	E-1	
APPENDIX F. EXPENDABLE SUPPLIES AND MATERIALS LIST	F-1	
Section I. Introduction	F-1	
II. Expendable Supplies and Materials List	F-1	

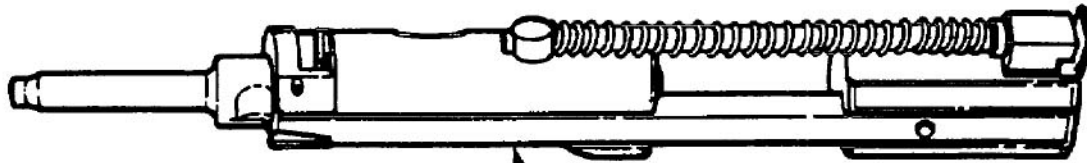

BOLT ADAPTER
ASSEMBLY

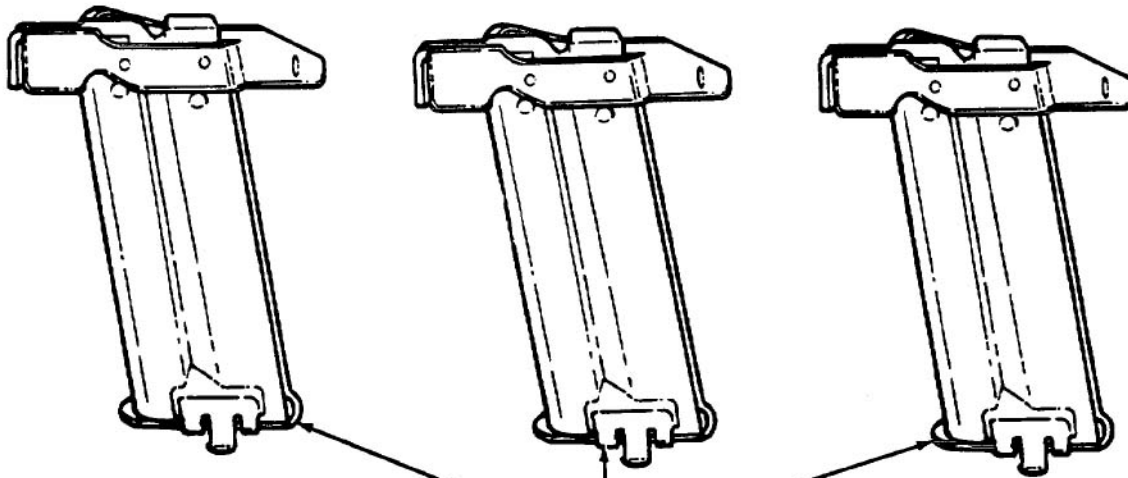

MAGAZINE ADAPTER
ASSEMBLY

CHAPTER 1 INTRODUCTION

CHAPTER OVERVIEW

This chapter contains general information equipment description and data about the conversion kit.

Section I. GENERAL INFORMATION

1-1. SCOPE. These instructions are for your use as the operator and organizational maintenance personnel. They apply to the conversion kit (caliber .22 rimfire adapter) for 5.56-mm M16 and M16A1 rifles.

1-2. MAINTENANCE FORMS AND RECORDS. Maintenance forms and records which you are required to use are listed and explained in DA PAM 738-750.

1-3. ADMINISTRATIVE STORAGE. Refer to TM 740-90-1.

1-4. REPORTING EQUIPMENT IMPROVEMENT RECOMMENDATIONS (EIR). If your conversion kit needs improvement, let us know. Send us an EIR. You, the user, are the only one who can tell us what you don't like about your equipment. Let us know why you don't like the design or performance. Put it on an SF 368

(Quality Deficiency Report). Mail it to us at Commander, US Army Armament, Munitions and Chemical Command, ATTN: DRSMC-MAO (R), Rock Island, IL 61299. We'll send you a reply.

1-5. HAND RECEIPT. This manual has a companion document with a TM number followed by "-HR" (which stands for Hand Receipt). The TM 96920-363-12&P-HR consists of preprinted hand receipts (DA Form 2062) that list end item related equipment (i.e., COEI, BII, and AAL) you must account for. As an aid to property accountability, additional -HR manuals may be requisitioned from the following source in accordance with procedures in Chapter 3, AR 310-2: The US Army Adjutant General Publications Center, 2800 Eastern Boulevard, Baltimore, MD 21220.

Section II. EQUIPMENT DESCRIPTION AND DATA

1-6. DESCRIPTION.

a. General. The conversion kit is designed to adapt the M16 and M16A1 rifles to fire caliber .22 rimfire ammunition (long rifle standard velocity only). The conversion kit was developed specifically for training purposes. Each conversion kit consists of one bolt adapter assembly and three magazine adapter assemblies.

b. Bolt Adapter Assembly. The bolt adapter assembly is designed to replace the standard bolt carrier group without any modifications to the rifle. It will not change the appearance, feel, or weight of the rifle, and it will not affect performance or operating procedure when the rifle is in the semiautomatic mode. The rifle will not fire in the automatic mode, nor will the bolt assist function when the bolt adapter assembly is installed.

c. Magazine Adapter Assembly. The magazine adapter assembly has a maximum capacity of 10

cartridges and is designed to fit into a standard magazine.

1-7. PERFORMANCE DATA.

a. Bolt Adapter Assembly.

Length 222.25 mm (8.75 in.)
Weight 0.45 kg (1 lb)

b. Magazine Adapter Assembly.

Ammunition:
Caliber 22
Type commercial long rifle ball
Length 76.2 mm (3 in.)
Weight 113.4 g (4 oz)

CHAPTER 2 OPERATING INSTRUCTIONS

CHAPTER OVERVIEW

This chapter contains all the instructions required to operate the M16 and M16A1 rifles with the conversion kit. It includes installation and operation of the conversion kit and operator's preventive maintenance checks and services.

Section I. OPERATING INSTRUCTIONS

2-1. GENERAL.

- a. This section contains installation procedures and operating instructions required to maintain proper operation of conversion kit with the M16 and M16A1 rifles.
- b. For operating instructions for the M16 and M16A1 rifles, refer to TM 91005-249-10.
- c. Battle sight zero is obtained at 25 meters using the procedures outlined in TM 9-1005-249-10.
- d. At range up to 50 meters, the .22 long rifle ammunition has generally the same trajectory as the 5.56 mm ammunition.
- e. At ranges of 75 and 125 meters the .22 long

rifle ammunition requires hold-off aiming. The conversion kit should not be used for longer ranges.

2-2. INSTALLATION OF BOLT ADAPTER ASSEMBLY.

WARNING

Before installing conversion kit, be sure to clear rifle (TM 9-1005-249-10) and position selector lever on SAFE.

NOTE

Perform all maintenance procedures on the rifle and magazine as required by TM 9-1005-249-10.

- a. Remove bolt carrier group.

1. DEPRESS TAKEDOWN PIN. THEN PIVOT OPEN UPPER AND LOWER RECEIVERS

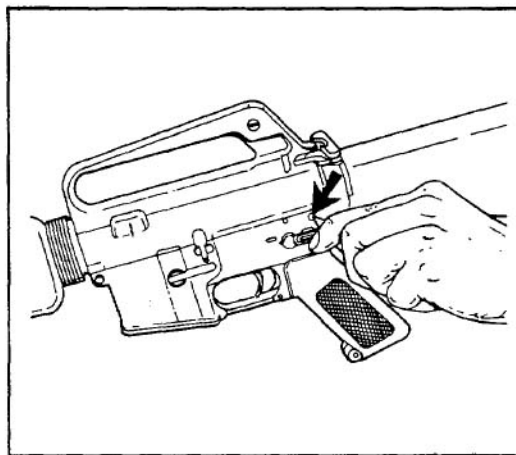

2. PULL BACK CHARGING HANDLE AND BOLT CARRIER GROUP.

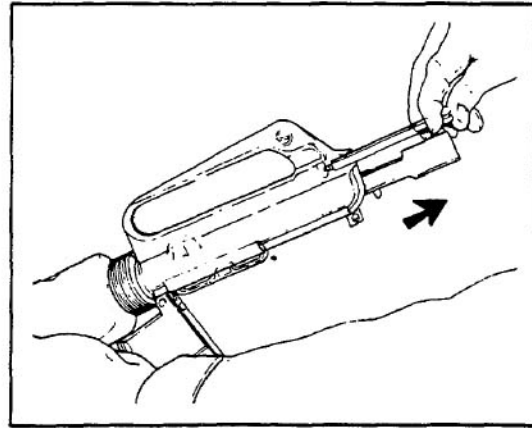

3. REMOVE BOLT CARRIER GROUP.

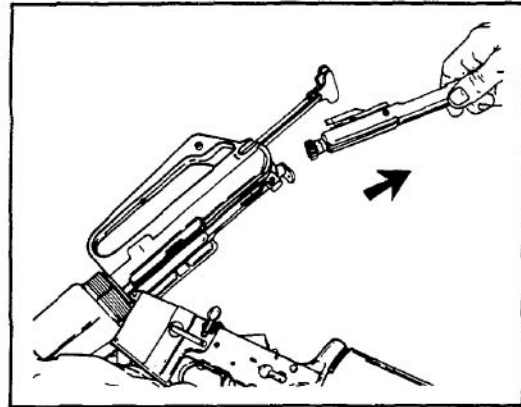

- b. Install bolt adapter assembly.

CAUTION

Do not force the adapter into the upper receiver.

NOTE

Before installing bolt adapter assembly, visually inspect it for proper assembly and damaged or missing parts.

When retracting the bolt, ensure there is free movement between bolt adapter assembly and slides of the receiver.

1. SLIDE IN BOLT ADAPTER ASSEMBLY.

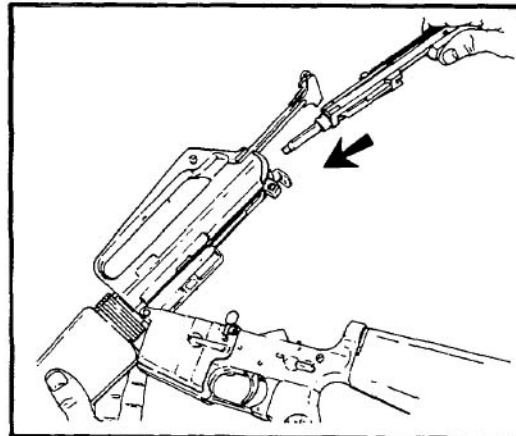

2. PUSH IN CHARGING HANDLE AND BOLT ADAPTER ASSEMBLY TOGETHER.

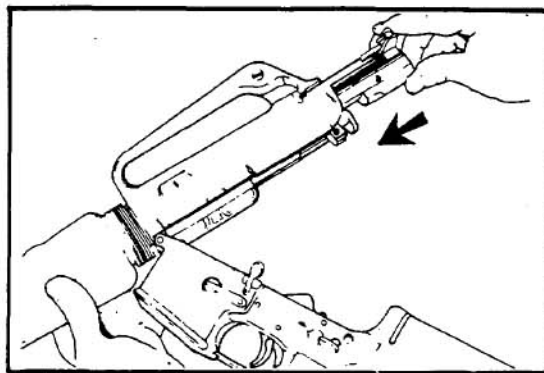

CAUTION

Selector lever must be on SAFE or SEMI before closing upper receiver.

3. CLOSE UPPER AND LOWER RECEIVERS. PUSH IN TAKEDOWN PIN.

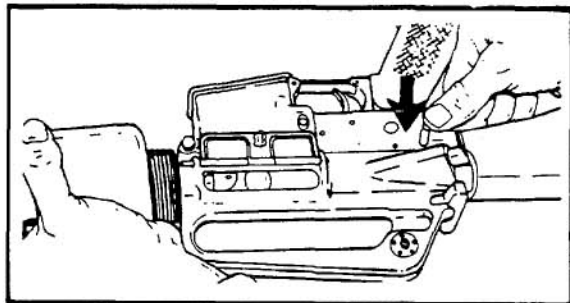

4. PULL CHARGING HANDLE AND RELEASE TWO TIMES, SNAPPING THE BOLT FORWARD TO SEAT THE ADAPTER.

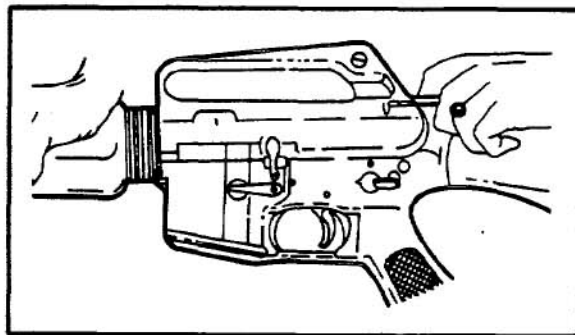

c. Perform functional check of safe and semiautomatic modes in accordance with TM 9-1005-249-10.

d. Additional operating information and safety equipment required when operating the M261 conversion kit and the M16A1 rifle.

- (1) The design and interface of the M261 conversion kit and the M16A1 rifle are such that a Cal. .22 rimfire cartridge can be fired by the breech bolt out of battery (cartridge not fully chambered). The cartridge case will rupture when it is fired without support of the chamber. In this case, the cartridge case can

partially fragment, producing the risk of eye injury to the shooter as well as to personnel near the ejection port (right side) of the M16A1 rifle.

- (2) Basic Issue Items (BII) are additional equipment used for safety. Use these safety items when operating and training with the M261 conversion kit.
 - (a) Wear goggles when firing or when close to the shooter. If you wear eyeglasses, wear goggles over them.
 - (b) Install rimfire brass deflector to trap ejected cartridge brass and any brass fragments during firing.

WARNING

Safety goggles are required for all shooters and other personnel in close proximity to the shooter. A rimfire brass deflector installed on the rifle is also required. These items will help prevent possible eye damage due to malfunctions that can occur.

- (3) With selector on safe, close the adapter bolt by depressing the rifle bolt catch.
- (4) Insert the magazine containing the loaded magazine adapter into the rifle.
- (5) Pull the charging handle to the rear and release the handle so it will snap forward. DO NOT assist or ride the charging handle forward.
- (6) Place the selector on SEMI position. The rifle

1. POSITION THE ADAPTER APPROXIMATELY IN THE CENTER AND DEPRESS MAGAZINE ADAPTER ASSEMBLY INTO MAGAZINE.

is now ready to fire.

2-3. INSTALLATION OF MAGAZINE ADAPTER ASSEMBLY.

WARNING

Do not load more than 10 cartridges in the magazine adapter assembly.

- a. *Loading the Magazine Adapter Assembly.*
Load cartridges through the top of the magazine adapter assembly, either before or after the adapter assembly is installed in the magazine.
- b. *Installation of Magazine Adapter Assembly.*

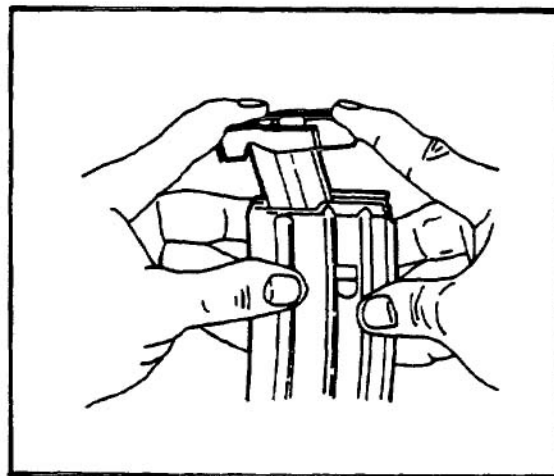

2. TILT ADAPTER ASSEMBLY ON ANGLE; HOOK BASE OF ADAPTER ASSEMBLY UNDER MAGAZINE LIPS.

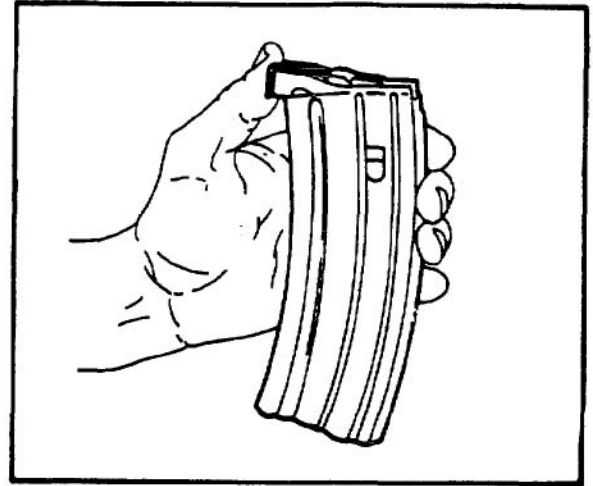

3. SLIDE ADAPTER ASSEMBLY ALL THE WAY IN.

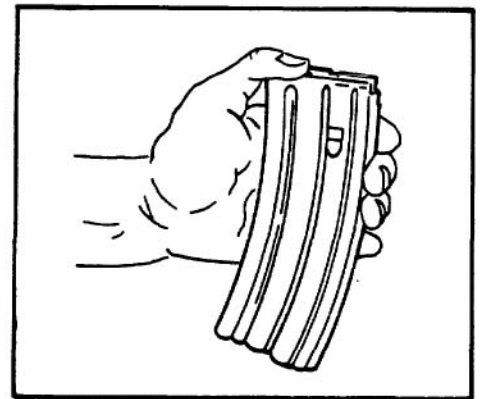

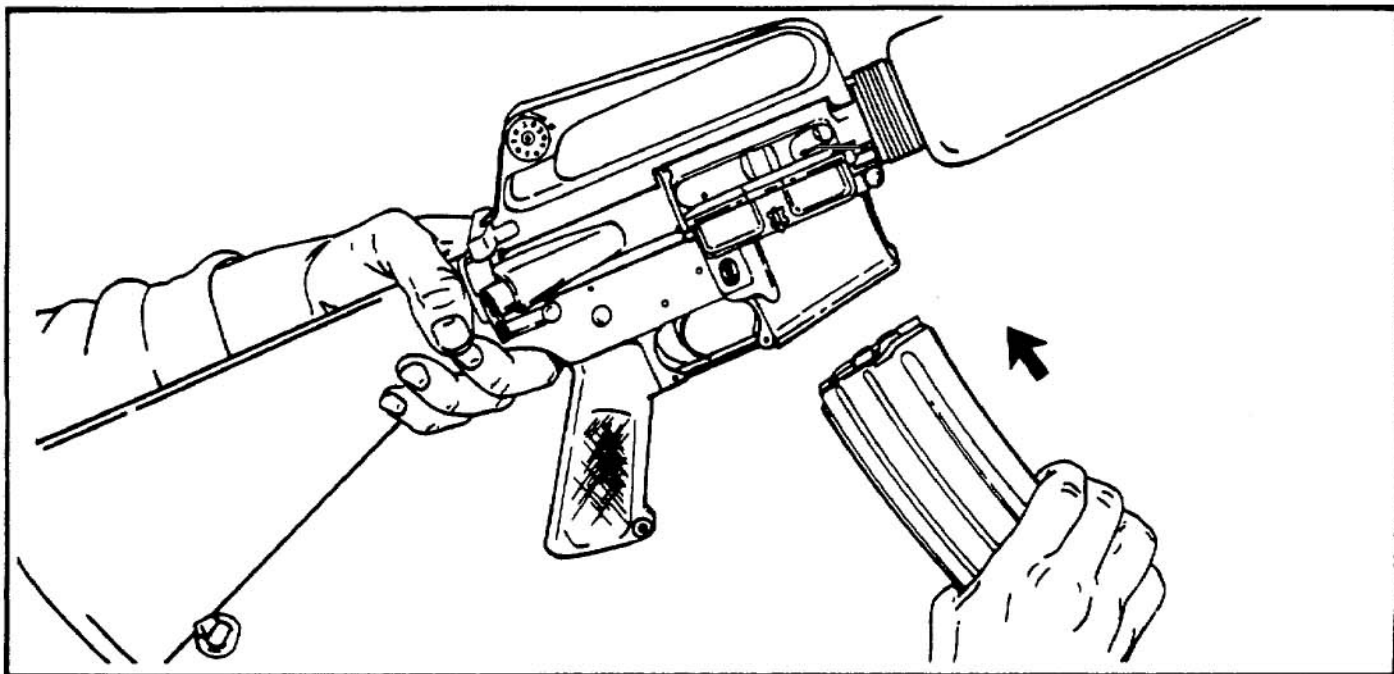
c. *Installation of Magazine in Rifle.*

1 PUSH MAGAZINE UPWARD UNTIL MAGAZINE CATCH ENGAGES AND HOLDS MAGAZINE.

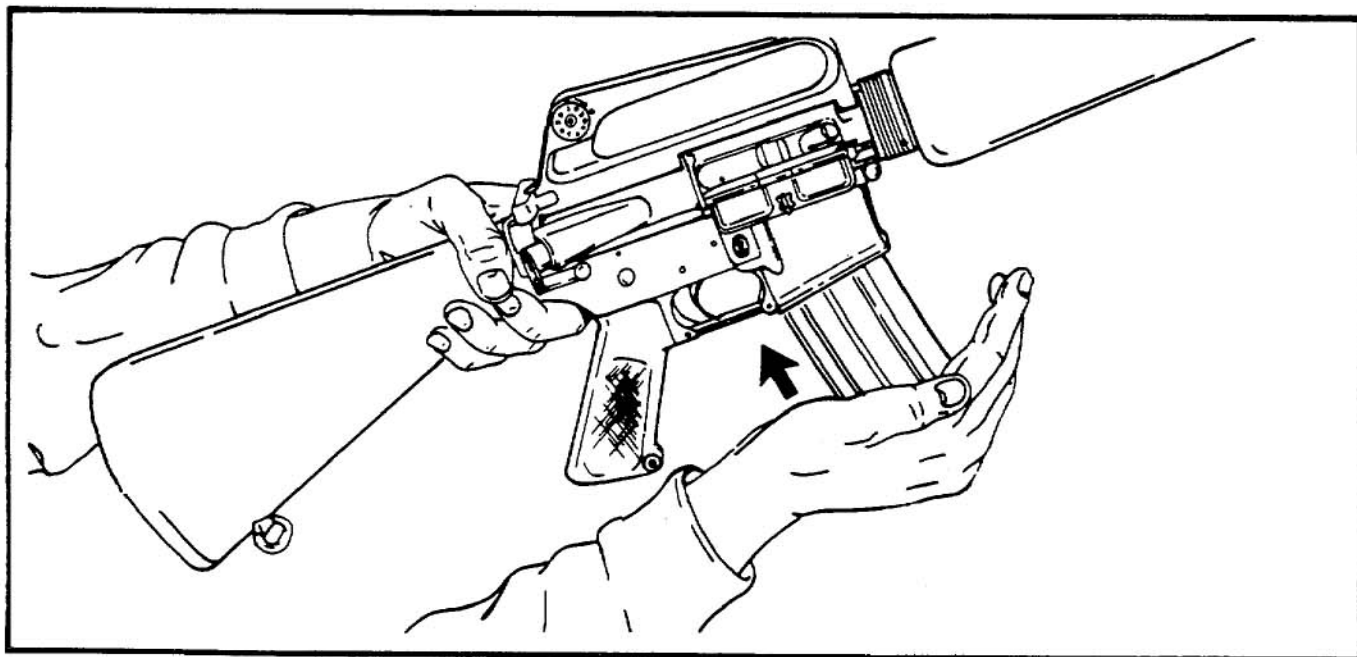

2 TAP UPWARD TO MAKE SURE MAGAZINE IS SEATED CORRECTLY.

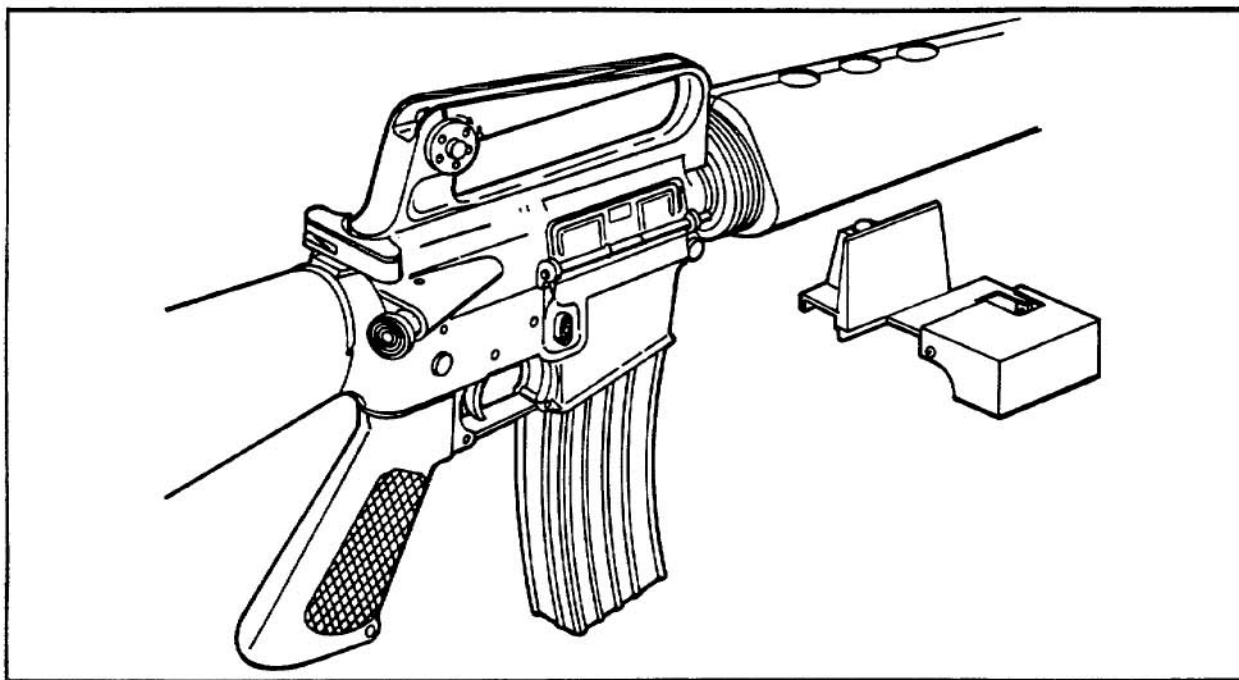
2-3.1 INSTALLATION OF RIMFIRE BRASS DEFLECTOR.

- 1 POSITION RIMFIRE BRASS DEFLECTOR INTO HANDLE OPEN AREA.**
- 2. ALINE DETENT PLUNGER OF DEFLECTOR WITH HOLE IN HANDLE AND SNAP IN PLACE.**

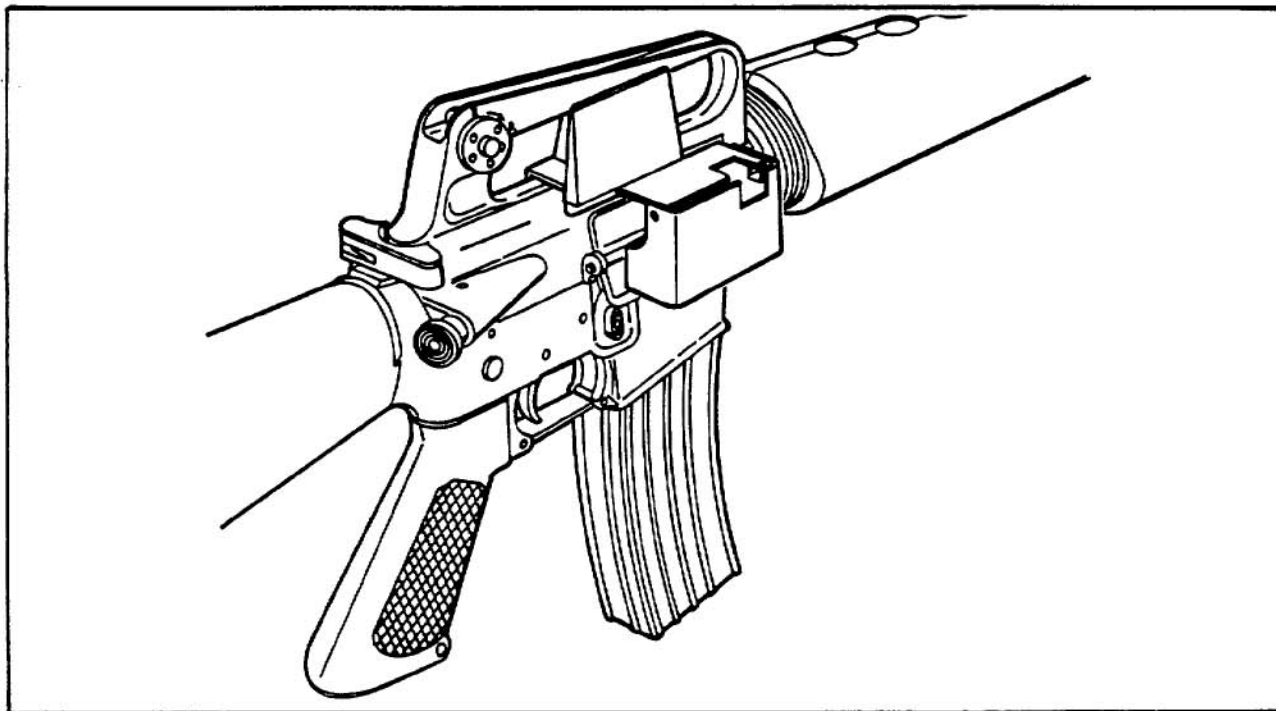

- 3 OPEN EJECTION PORT COVER OF RIFLE AND LOWER RIMFIRE BRASS DEFLECTOR AGAINST RIFLE.**

Section II. PREVENTIVE MAINTENANCE CHECKS AND SERVICES (PMCS)

2-4. GENERAL

a. To ensure maximum efficiency in operation; the conversion kit must be systematically inspected at intervals so defects can be discovered and corrected before they result in serious damage or failure. Preventive maintenance includes inspection, cleaning, lubrication, and repair. Always keep in mind the CAUTIONS and WARNINGS. Perform your before (B), during (D), and after (A) PMCS. If your equipment fails to operate, troubleshoot. Report any deficiencies using the proper forms. Refer to TM 38-750. For authorized levels of repair, see the maintenance allocation chart (MAC) in appendix B.

b. The PMCS table lists those checks and services which are required when the conversion kit is used with M16 and M16A1 rifles. All checks and services listed in the after (A) operations column will be performed after removing the conversion kit from the rifle (p3-6). The item number column shall be used as a source of item numbers for the TM number column on DA Form 2404, Equipment Inspection and Maintenance Worksheet, in recording results of PMCS.

c. Preventive maintenance checks and services for M16 and M16A1 rifles will be performed by the rifle operators as directed in TM 9-1005-249-10.

Table 2-1. PREVENTIVE MAINTENANCE CHECKS AND SERVICES

NOTE

Within designated interval, these checks are to be performed in the order listed.

B-Before

D-During

A-After

Item no.	Interval			ITEM TO BE INSPECTED Procedures	Equipment is not ready/ available if:
	B	D	A		
1.	●			<p>BOLT ADAPTER ASSEMBLY</p> <p>a. Visually inspect for proper assembly and check for damaged or missing parts. Report damaged or missing parts to organizational maintenance. If required, perform cleaning and lubrication procedures before installing. Refer to page 3-1.</p> <p>b. After installing, retract bolt to ensure free movement.</p> <p>c. Perform functional check to ensure proper operation. Refer to TM 9-1005-249-10.</p>	Parts are missing, damaged, or improperly assembled. It binds. It fails functional check.
 <p>The diagram shows a side view of the bolt adapter assembly. It consists of a barrel on the left, a bolt group in the middle, and a spring and pin on the right. Labels with arrows point to each of these components.</p>					
BOLT ADAPTER ASSEMBLY					

Table 2-1. PREVENTIVE MAINTENANCE CHECKS AND SERVICES (CONT)

B-Before D-During A-After

ITEM NO.	INTERVAL			Item to be inspected procedure	Equipment is not ready/available if:
	B	D	A		
2.		●		<p>BOLT ADAPTER ASSEMBLY</p> <p>a. Perform cleaning and lubrication procedures for every 500 rounds fired. Refer to page 3-1.</p> <p>b. Use procedures listed in TM 91005-249-10 to correct any malfunctions/stoppages. If bolt is malfunctioning, turn over to organizational maintenance.</p>	
3.			●	<p>BOLT ADAPTER ASSEMBLY</p> <p>a. Perform cleaning and lubrication procedures. Refer to page 3-1.</p> <p>b. Inspect for worn spots and damaged parts. Report all damaged parts to organizational maintenance. If, excessive carbon build up, turn in to organizational maintenance (unit armorer).</p>	
4.	●			<p>MAGAZINE ADAPTER ASSEMBLY</p> <p>Visually inspect for proper assembly and damaged or missing parts. Report damaged or missing parts to organizational maintenance. If required, clean and lubricate before installation. Refer to page 3-1.</p>	Parts are missing, damaged, or improperly assembled.
5.		●		<p>MAGAZINE ADAPTER ASSEMBLY</p> <p>Perform cleaning and lubrication procedures for every 500 rounds fired. Refer to page 3-1.</p>	
6.			●	<p>MAGAZINE ADAPTER ASSEMBLY</p> <p>a. Perform cleaning and lubrication procedures. Refer to page 3-1.</p> <p>b. Inspect for damaged parts. If damaged, turn in to organizational maintenance for repair/replacement. Clean and lubricate. Refer to page 3-1.</p>	

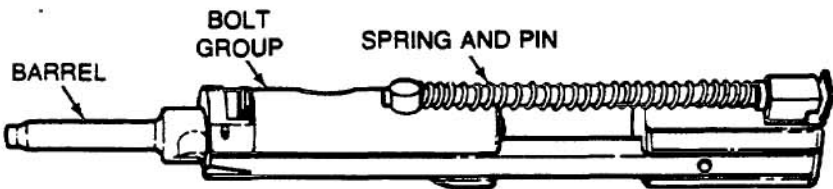
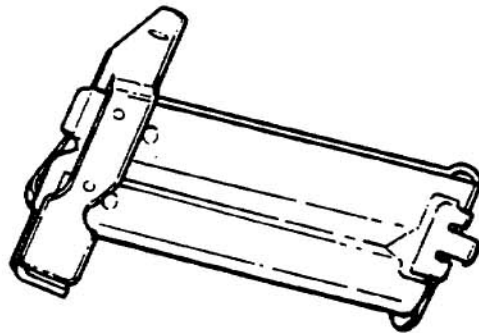

Section III. OPERATION UNDER UNUSUAL CONDITIONS

2-5. **GENERAL.** For operation of the M16 and M16A1 rifle under unusual conditions, refer to TM 9-1005-249-10.

Section IV. AMMUNITION

2-6. **GENERAL.**

CAUTION

Continuous firing (400-1000 rounds per weapon) of M861 cal.22 rimfire tracer ammo will result in lead particles fouling the M16A1 rifle gas system. This will cause the weapon not to fire in either semi-automatic or automatic mode. However, firing regular M193 5.56-mm ball ammo will clear the gas system. You should therefore do the following to prevent permanent blockage of the gas system and to clear the rifle of fouling:

- At the end of each training session (typically 400-1000 rounds per weapon), remove the rimfire adapter and reinstall the bolt carrier. Fire a 20/30 round magazine of 5.56-mm M193 ball ammo in the automatic mode in short bursts of 4 to 5 rounds.
- If the rifle won't fire in either semi or automatic mode, manually recharge and fire the weapon (using 5.56-mm ball ammo) for up to 10 rounds. Then fire an entire magazine as described above. This will clean the gas system so you can resume subcaliber firing.

Do not use western T-22 cal .22 ammunition in the rimfire adapters.

- a. Either the standard long rifle (ball), match, or M861 cal .22 rimfire tracer ammunition can be used with the M261 conversion kit.



Match

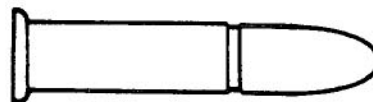

Ball

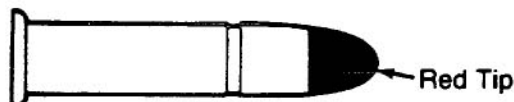

Rimfire Tracer, M861

- b. These are small arms ammunitions which are issued as complete rounds. A complete round (cartridge) consists of all the components necessary to fire the weapon once; that is, the projectile (bullet), cartridge case, propellant, and primer. The rimfire cartridge is composed of a brass case, a propellant, and a lead or lead-alloy bullet. The cartridge is approximately 1.0 inch long.
- c. For information on malfunctions involving ammunition and explosives, refer to AR 700-1300-8.

2-7. IDENTIFICATION AND MARKINGS.

- a. *General.* The ammunition is identified by information on the ammunition box. When ammunition is removed from its original box, the identification information, including nomenclature, shall be kept with the ammunition.
- b. *Markings.* The manufacturer's identification is stamped on the head of the cartridge case.

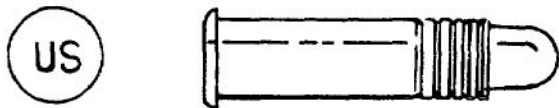

Caliber .22 Match Cartridge

- c. Cartridges should be protected from extended exposure to direct sunlight, moisture, and excessive humidity. Such exposure affects ballistic performance of cartridges.
- d. Keep cartridges dry, clean, and free of corrosion by wiping with a dry, clean cloth.
- e. Do not bend or score the soft lead nose of the bullet during magazine loading.
- f. The cartridge case should be fully to the rear of the adapter.

WARNING

Do not fire corroded ammunition, dented cartridges, cartridges with loose bullets, or cartridges exposed to extreme heat, 135°F (57°C), until they have cooled.

2-8. CARE, HANDLING, AND) PRESERVATION.

- a. Ammunition is packed to withstand conditions normally encountered in handling, storage, transport, and field use.
- b. Damaged ammunition boxes must be repaired or replaced immediately, with all identification markings transferred to the new ammunition boxes.

Do not lubricate cartridges. A buildup of oil or grease may collect in the weapon and create excessive and dangerous chamber pressure when fired.

- g. For additional instructions in the care, handling, and preservation of ammunition, refer to TM 9-1300-206.

CHAPTER 3 OPERATOR MAINTENANCE INSTRUCTIONS

CHAPTER OVERVIEW

This chapter contains the instructions and information needed by the operator to keep the conversion kit in good operating condition. This chapter includes:

- a. Lubrication instructions.
- b. Troubleshooting.
- c. Maintenance instructions.

Section I. LUBRICATION INSTRUCTIONS

3-1. GENERAL.

- a. This section contains pertinent lubrication instructions for operator maintenance.
- b. For lubrication instructions for the M16 and M16A1 rifles, refer to TM 9-1005-24910.
- c. For expendable supplies and materials authorized, refer to appendix F.

3-2. BOLT ADAPTER ASSEMBLY.

- a. Disassemble bolt adapter assembly (p 3-4).

- b. Wipe all parts clean with clean rags (item 9, app F) or swabs (item 10, app F) and cleaner, lubricant and preservative (CLP) (item 4, app F). Then heavily lubricate outer surfaces of straight pin, spring, guide rail, bolt, and rail support with CLP.

3-3. MAGAZINE ADAPTER ASSEMBLY.

- a. Disassemble magazine adapter assembly (para 3-7b).
- b. Wipe all parts clean with clean rags or swabs and CLP. Then lightly lubricate spring with CLP.

Section II. TROUBLESHOOTING

3-4. GENERAL.

- a. This section contains the troubleshooting information for locating and correcting most of the operating troubles which may develop while the conversion kit is being used with M16 and M16A1

rifles. Each malfunction is followed by a list of test or inspections which will help you to determine the corrective actions for you to take. You should perform the tests/inspections and corrective actions in the order listed.

Table 3-1. TROUBLESHOOTING

MALFUNCTION
TEST OR INSPECTION
CORRECTIVE ACTION

1. FAILS TO FIRE

- Step 1.* Check for broken or defective firing pin.
Notify organizational maintenance.
- Step 2.* Check for carbon or fouling accumulation on firing pin.
Notify organizational maintenance.
- Step 3.* Check for improperly assembled bolt adapter assembly and worn, broken, or missing parts.
Notify organizational maintenance.

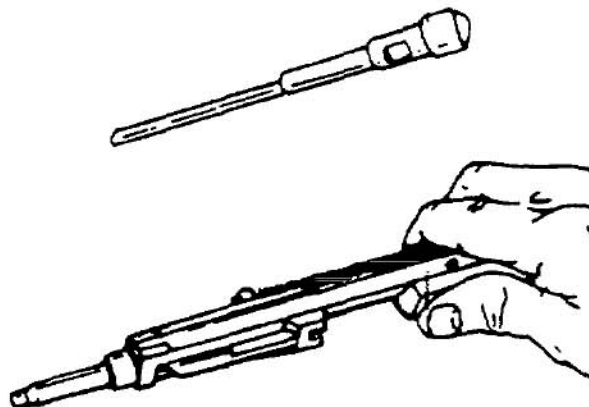

Table 3-1. TROUBLESHOOTING (CONT)

MALFUNCTION

TEST OR INSPECTION

CORRECTIVE ACTION

- Step 4.* Check for too much oil in firing pin recess of bolt.
Wipe off excess oil.
- Step 5.* Check for dirty or unlubricated adapters.
Clean and lubricate.
- Step 6.* Fails to fire after first round or every other round.
Check selector to be sure it is on SEMI.

**2. FAILS TO EXTRACT**

- Step 1.* If firing tracer ammo, check for fouling of gas system.
Refer to CAUTION on page 2-8.
- Step 2.* Check for dirty or corroded ammunition.
Remove ammunition from magazine and clean.
- Step 3.* Check for carbon buildup in extractor recess or extractor lip.
Notify organizational maintenance.
- Step 4.* Check for defective extractor, extractor spring, and extractor plunger.
Notify organizational maintenance.
- Step 5.* Check for improperly assembled bolt adapter assembly and worn, broken, or missing parts.
Notify organizational maintenance.

**3. FAILS TO EJECT**

- Step 1.* Check for improperly assembled bolt adapter assembly and worn, broken, or missing parts.
Notify organizational maintenance.
- Step 2.* Check for defective extractor, extractor spring, and extractor plunger.
Notify organizational maintenance.
- Step 3.* Check for bent or improperly assembled cartridge retainer.
Notify organizational maintenance for replacement.

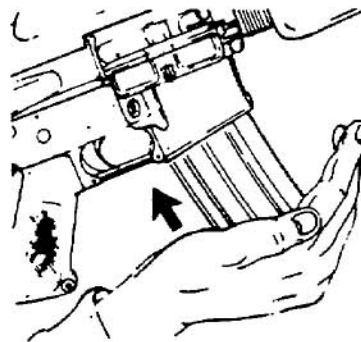
**4. FAILS TO FEED**

- Step 1.* Check for improperly seated magazine.
Tap upward on bottom of magazine.
(To adjust magazine catch, refer to TM 91005-249-10.)
- Step 2.* Check for dirty or corroded ammunition.
Remove ammunition from magazine adapter assembly and clean.
- Step 3.* Check for dirty magazine adapter assembly.
Disassemble and clean.
- Step 4.* Check for too many rounds loaded in magazine adapter assembly.
Remove excess round(s).
- Step 5.* Check for improper installation of magazine adapter assembly in standard magazine.
Remove and install properly.

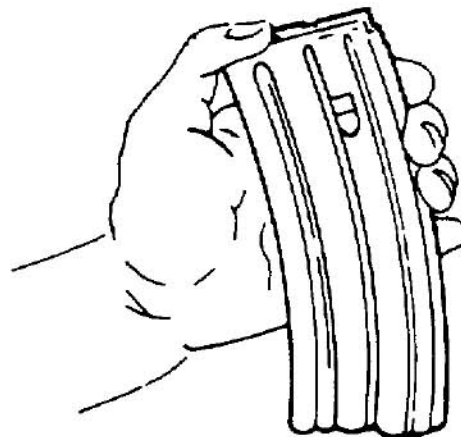

MALFUNCTION

TEST OR INSPECTION

CORRECTIVE ACTION

- Step 6.* Check for burred or broken lips on magazine adapter assembly.
Replace magazine adapter assembly.
- Step 7.* Check for defective follower on magazine adapter assembly.
Replace magazine adapter assembly.
- Step 8.* Check for weak or broken magazine adapter assembly spring.
Replace magazine adapter assembly.
- Step 9.* Check for dented or damaged magazine adapter assembly.
Replace magazine adapter assembly.

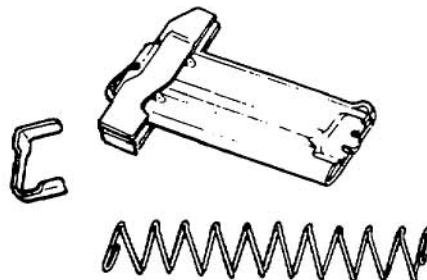

5. HAS DOUBLE FEED

- Check for defective magazine adapter assembly.
Replace magazine adapter assembly.

6. FAILS TO CHAMBER

- Step 1.* Check for dirty or corroded ammunition.
Remove ammunition from magazine adapter assembly and clean.
- Step 2.* Check for damaged ammunition.
Replace ammunition.

7. FAILS TO LOCK

- Step 1.* Check for restricted movement of bolt adapter assembly.
Perform normal cleaning and lubricating procedures to bolt adapter assembly. Clean and lubricate receiver (TM 91005-24910). With the upper receiver held in the upright position and the charging handle removed, install the bolt adapter assembly. Slowly slide the bolt adapter assembly back and forth on the slides of the receiver to determine proper fit, alignment, and free movement. If binding occurs, turn the bolt adapter assembly in to organizational maintenance.
- Step 2.* Check for improperly assembled bolt adapter assembly and worn, broken, or missing parts.
Notify organizational maintenance.

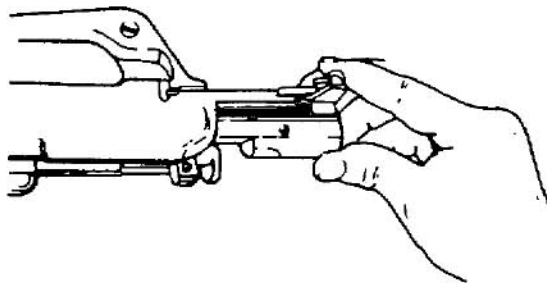

8. HAS SHORT RECOIL

- Check for restricted movement of bolt adapter assembly.
See step 1 of malfunction 7, FAILS TO LOCK..

- b. This manual cannot list all possible malfunctions that may occur, nor all tests or inspections and corrective actions. If a malfunction is not listed (except when malfunctions and causes are obvious), or is not corrected by listed corrective actions, notify your supervisor.

NOTE

- When substandard, corroded or damaged caliber .22 ammunition is used, malfunctions listed in troubleshooting table will occur.
- c. For troubleshooting procedures for M16 and M16A1 rifles, refer to TM 9-1005-24910.

Section III. MAINTENANCE OF CONVERSION KIT

3-5. GENERAL. Operator maintenance of conversion kit consists of removal, disassembly, cleaning, inspection, and assembly procedures in accordance with the maintenance allocation chart (app C) and the instructions contained in this section.

3-6. BOLT ADAPTER ASSEMBLY**NOTE**

Disassembly by operator will be limited to removal of straight pin, spring, and bolt.

- a. Remove bolt adapter assembly.

- 1 DEPRESS TAKEDOWN PIN. THEN PIVOT OPEN UPPER AND LOWER RECEIVERS.**

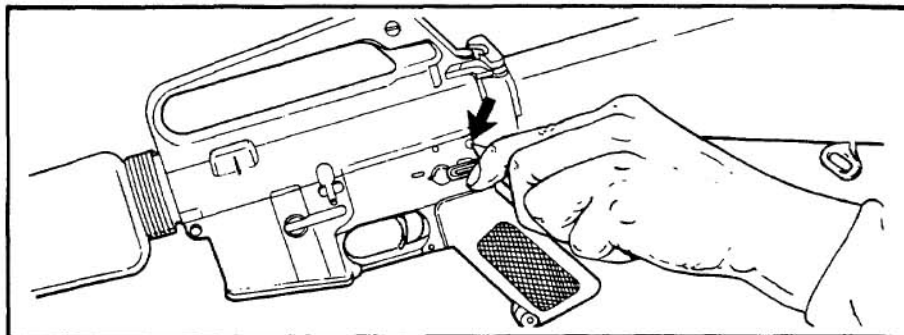

- 2 PULL BACK CHARGING HANDLE AND BOLT ADAPTER ASSEMBLY.**

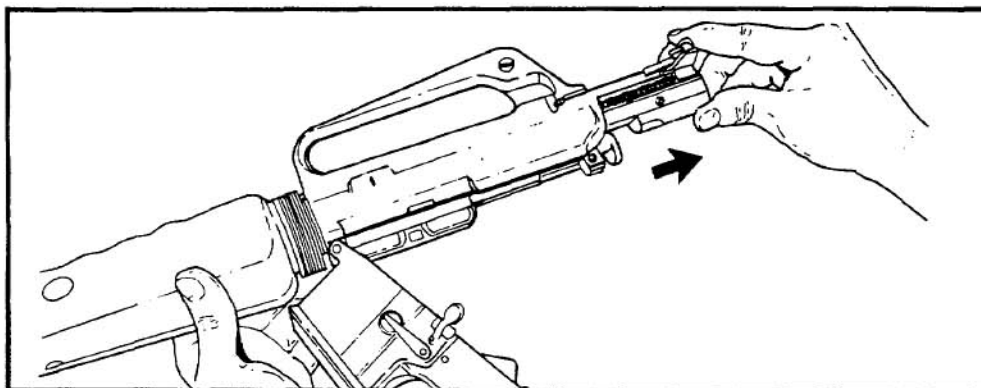

- 3 REMOVE BOLT ADAPTER ASSEMBLY.**

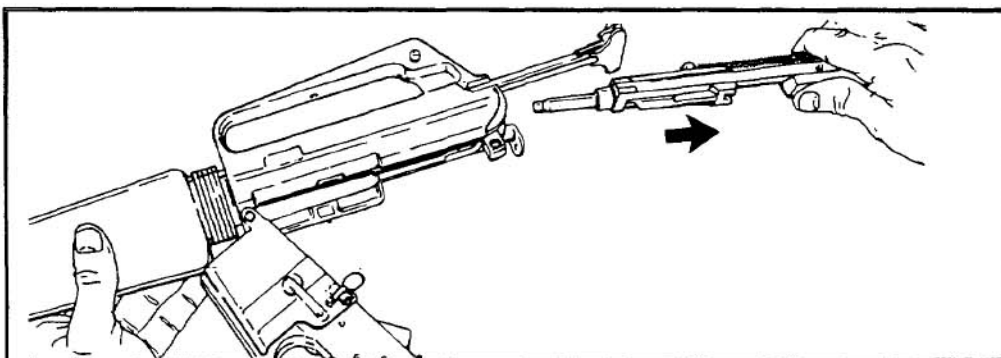

b. Disassemble bolt adapter assembly.

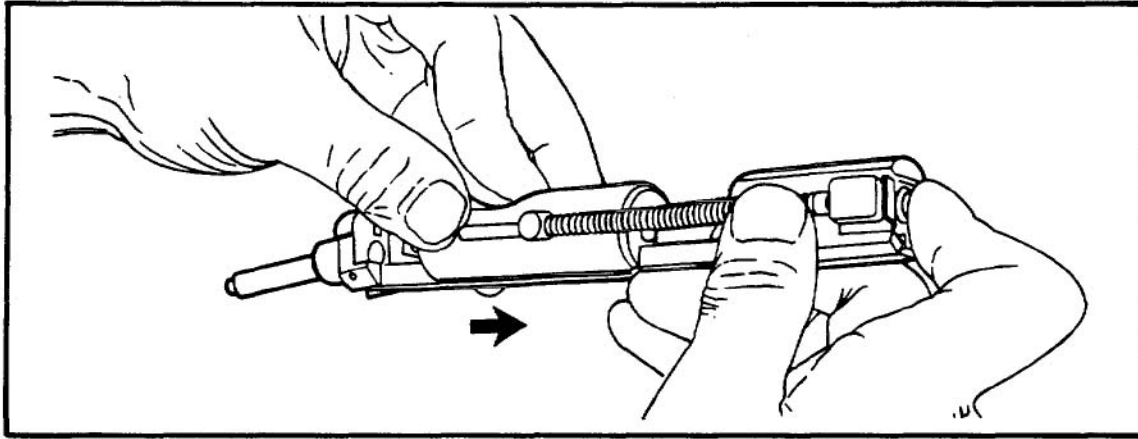

- 1 PUSH THE BOLT ONE-HALF INCH TO THE REAR AND ROTATE THE BOLT COUNTERCLOCKWISE TO REMOVE FROM THE GUIDE RAIL, THEN MOVE IT FORWARD OFF THE SPRING AND STRAIGHT PIN.

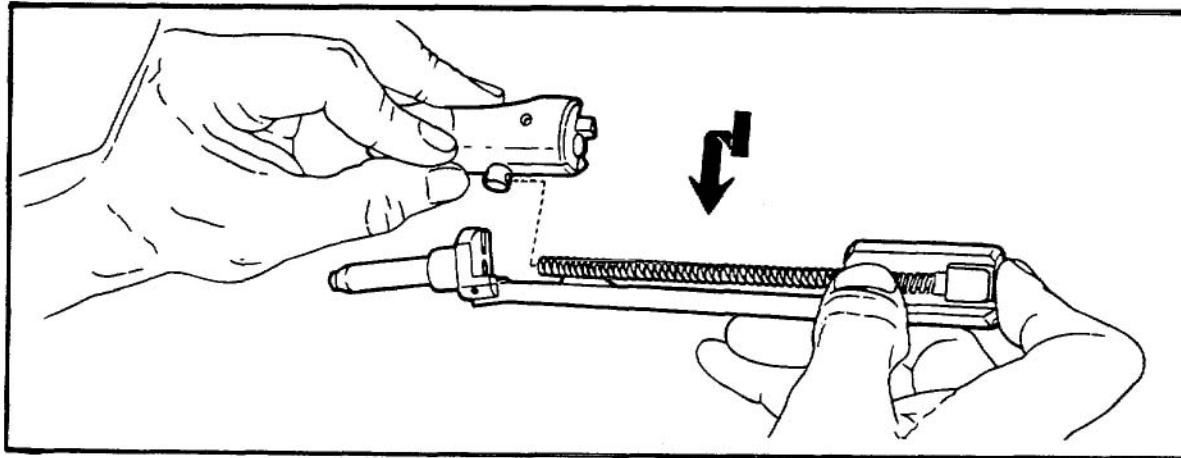

- 2 REMOVE SPRING AND STRAIGHT PIN.

WARNING

Do not load ammunition into the bolt adapter or snap the adapter bolt forward when the adapter is not installed in the rifle.

c. Clean, inspect, and repair the bolt adapter assembly as follows:

(1) Cleaning.

- (a) Using a small bore brush, remove carbon deposits, corrosion, and dirt from all parts. After cleaning, wipe all parts clean with clean swabs or rags.
- (b) Inspect interior parts of bolt adapter assembly for carbon buildup. If identified, turn in to organizational maintenance for cleaning.

(2) Inspection. Inspect all parts for serviceability. Inspect for bent, worn, broken, or missing parts.

(3) Repair. Turn bolt adapter assembly in to organizational maintenance for repair.

d. Assemble bolt adapter assembly.

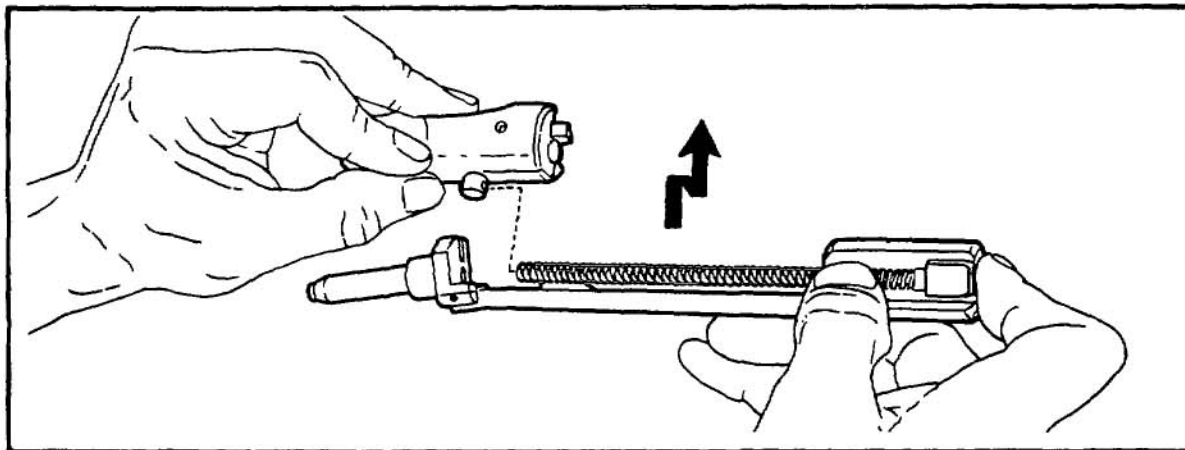

1 INSTALL STRAIGHT PIN AND SPRING.

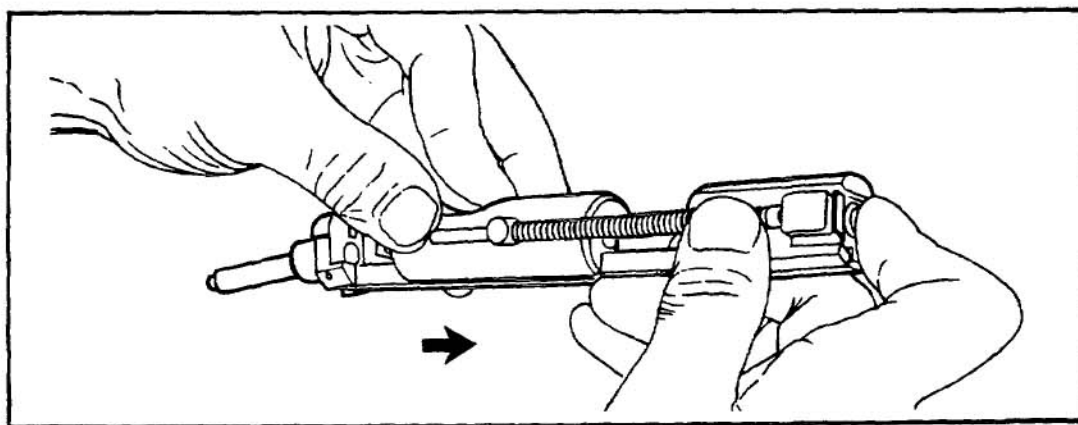

2 INSTALL BOLT TO STRAIGHT PIN AND SPRING. COMPRESS SPRING UNTIL CONNECTION ON BOLT IS ALINED WITH CONNECTION ON RAIL. ROTATE BOLT CLOCKWISE TO CONNECT IT TO THE RAIL. ALLOW BOLT TO CLOSE.

3-7. MAGAZINE ADAPTER ASSEMBLY.

- a. Remove magazine and magazine assembly.

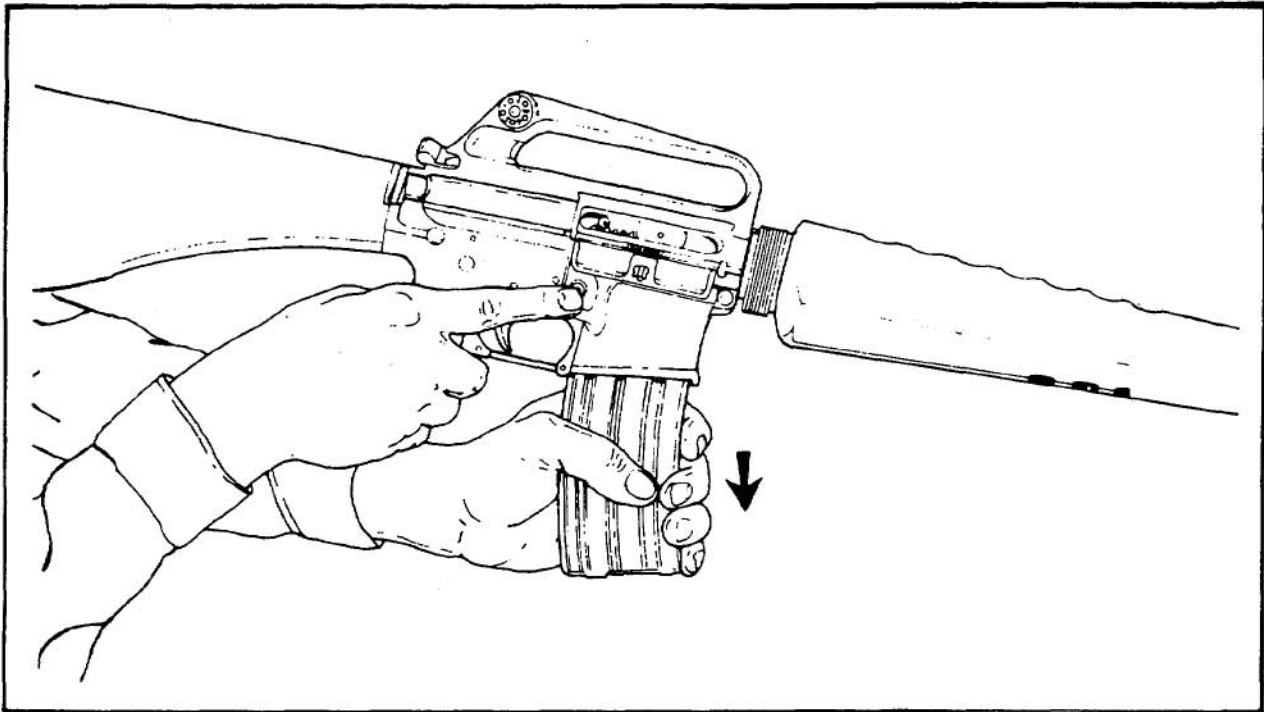

- 1 REMOVE MAGAZINE FROM RIFLE BY PRESSING CATCH BUTTON AND PULLING MAGAZINE DOWN.

WARNING

The magazine adapter is under spring tension. Be careful and don't let it get away from you. It could be dangerous.

- 2 PRESS THE REAR OF THE MAGAZINE ADAPTER ASSEMBLY DOWN. THEN RAISE THE FRONT SLIGHTLY AND SLIDE THE ADAPTER FORWARD TO REMOVE.

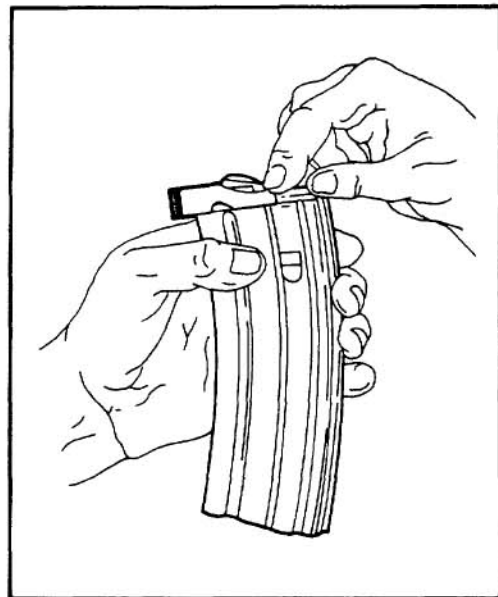

b. Disassemble magazine adapter assembly.

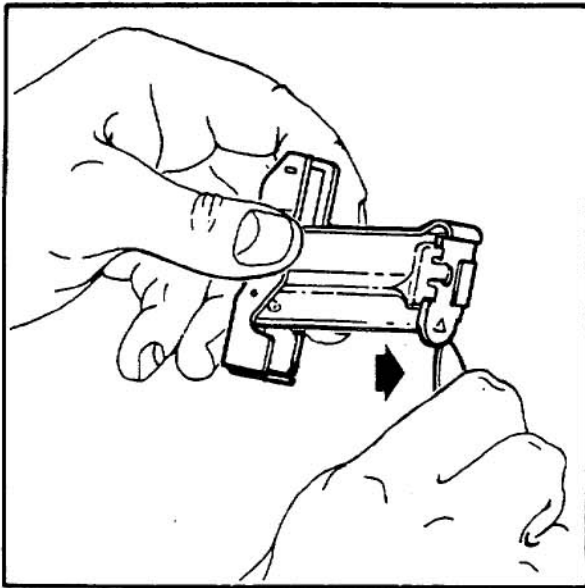

1 PULL UP TO RELEASE MAGAZINE BASE CATCH

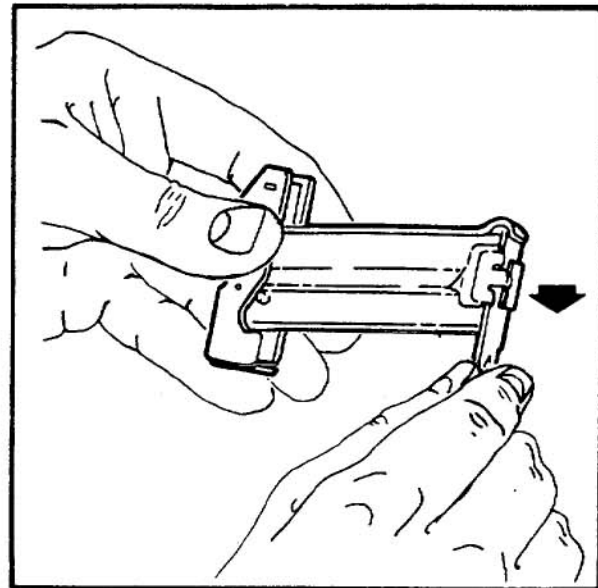

2 REMOVE MAGAZINE BASE.

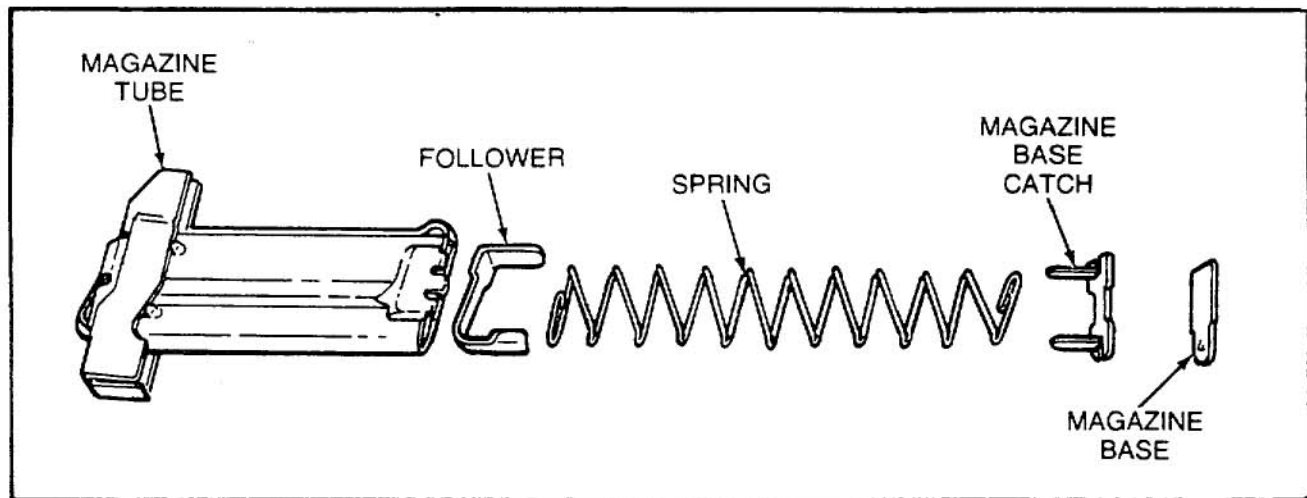

3 REMOVE MAGAZINE BASE CATCH, SPRING, AND FOLLOWER.

c. Clean dirt or corrosion from magazine tube spring and follower. Using swabs (item 10, app F), rags (item 9, app F), and CLP (item 4, app F), clean and lubricate.

d. Inspect all parts for serviceability. Inspect magazine tube for dents, cracks, and bent or damaged feeder lips. If any of the parts are missing, worn, broken, or otherwise defective, report to organizational maintenance for replacement.

- e. Assemble magazine adapter assembly.

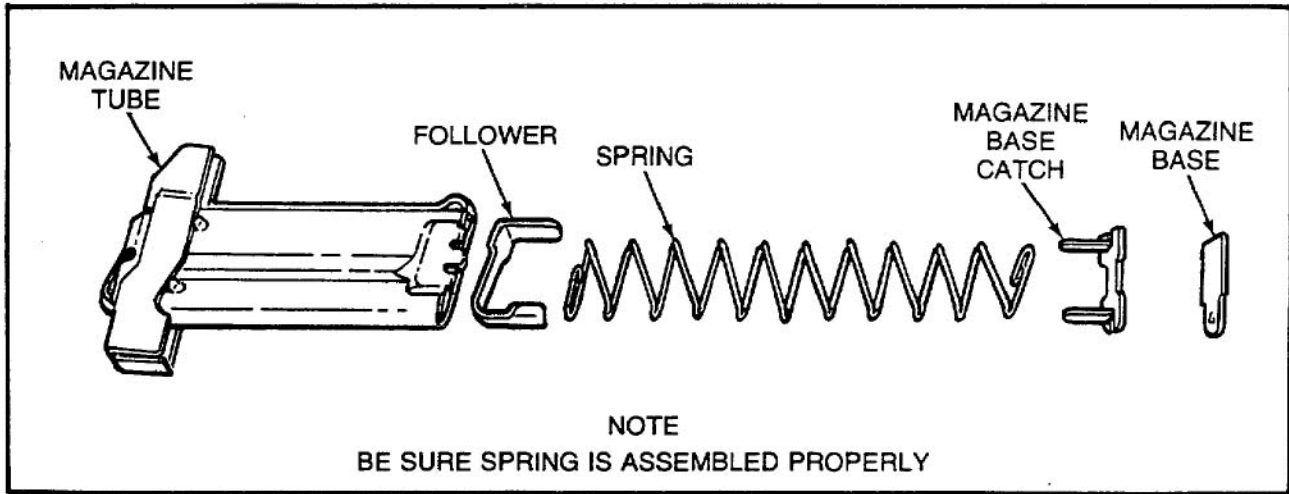

1. INSTALL FOLLOWER, SPRING, AND MAGAZINE BASE CATCH.

2. INSTALL MAGAZINE BASE.

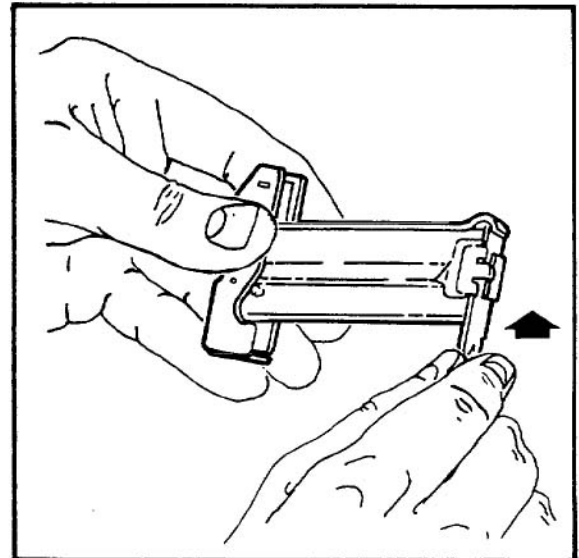

CHAPTER 4 ORGANIZATIONAL MAINTENANCE INSTRUCTIONS

CHAPTER OVERVIEW

This chapter contains the instructions and information needed by organizational maintenance personnel to keep the conversion kit in good repair. This chapter includes:

- a. Service upon receipt of materiel
- b. Lubrication instructions

Section I. SERVICE UPON RECEIPT OF MATERIEL

4-1. GENERAL.

- a. When conversion kits are received, it is the responsibility of the officer in charge to determine whether the materiel has been properly prepared for service by the supplying organization and to be sure it is in condition to perform its function.
- b. A record will be made of all missing parts and/or malfunctions and will be reported through appropriate channels. Corrective action will be initiated as quickly as possible.

4-2. SERVICE UPON RECEIPT OF MATERIEL.

- a. *Conversion Kit.*
 - (1) Visually inspect the bolt adapter assembly and magazine adapter assembly for proper assembly and damaged or missing parts.
 - (2) Clean and lubricate (p 3-1).
- b. *M16 and M16A1 Rifles.* Refer to TM 9-1005-249-20 for service upon receipt of materiel.

Section II. LUBRICATION INSTRUCTIONS

4-3. GENERAL. This section contains pertinent lubrication instructions for organizational maintenance.

4-4. EXPENDABLE AND CONSUMABLE SUPPLIES.

A list of expendable and consumable supplies used in the care, cleaning, lubricating, and maintenance of the equipment is contained in appendix F.

4-5. LUBRICATION OF BOLT ADAPTER ASSEMBLY.

- a. *Disassembly.* Refer to page 3-4.
- b. *Cleaning.* Refer to page 3-6.
- c. *Lubrication.* Refer to page 3-1 and appendix F.

NOTE

Do not lubricate inside the bolt adapter assembly barrel or recesses.

- (1) Lightly lubricate outer surface of bolt, rail support, guide rail, support lug, and barrel.
- (2) Lightly lubricate firing pin, extractor plunger, and extractor.

Section III. PREVENTIVE MAINTENANCE CHECKS AND SERVICES (PMCS)

4-6. GENERAL. For preventive maintenance checks and services to be performed by organizational maintenance, refer to the following table.

Table 4-1. ORGANIZATIONAL PREVENTIVE MAINTENANCE CHECKS AND SERVICES
QUARTERLY SCHEDULE

Item No.	Item to be inspected	Procedures
1	Conversion Kit	Visually inspect for: Proper assembly Damaged parts Missing parts Excessive carbon buildup on internal parts

Section IV. TROUBLESHOOTING

4-7. GENERAL.

- a. This section contains the troubleshooting information for locating and correcting most of the operating troubles which may develop while the conversion kit is being used with M16 and M16A1 rifles. Each malfunction is

followed by a list of tests or inspections which will help you to determine the corrective actions for you to take. You should perform the tests/inspections and corrective actions in the order listed.

Table 4-2. TROUBLESHOOTING

MALFUNCTION	TEST OR INSPECTION	CORRECTIVE ACTION
-------------	--------------------	-------------------

1. FAILS TO FIRE

- Step 1. Check for broken or defective firing pin.
Replace firing pin.

- Step 2. Check for carbon or fouling accumulation on firing pin.
Clean firing pin.

- Step 3. Check for improperly assembled bolt adapter assembly and worn, broken or missing parts.
Replace worn, broken, or missing parts; assemble correctly (p 3-6).

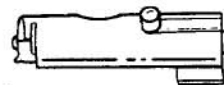
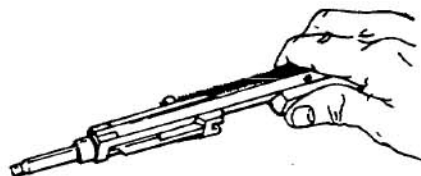

- Step 4. Check for too much oil in firing pin recess of bolt.
Wipe off excess oil.

MALFUNCTION
TEST OR INSPECTION
CORRECTIVE ACTION

2. FAILS TO EXTRACT

Step 1. Check for carbon buildup in extractor recess or extractor lip.
Remove carbon.

Step 2. Check for defective extractor, extractor spring, and extractor plunger.
Replace defective parts.



Step 3. Check for improperly assembled bolt adapter assembly and worn, broken, or missing parts.
Replace worn, broken, or missing parts; assemble correctly.

3. FAILS TO EJECT

Step 1. Check for improperly assembled bolt adapter assembly and worn, broken, or missing parts.
Replace worn broken, or missing parts; assemble correctly.

Step 2. Check for defective extractor, extractor spring, extractor plunger, and cartridge retainer.
Replace defective parts.

4. FAILS TO LOCK

Step 1. Check for restricted movement of bolt adapter assembly.

Perform normal cleaning and lubricating procedures to bolt adapter assembly. Clean and lubricate receiver (refer to TM 91005-24910). With the upper receiver held in the upright position and the charging handle removed, install the bolt adapter assembly. Slowly slide the bolt adapter assembly back and forth on the slides of the receiver to determine proper fit, alignment, and free movement. If binding occurs, get a new kit.

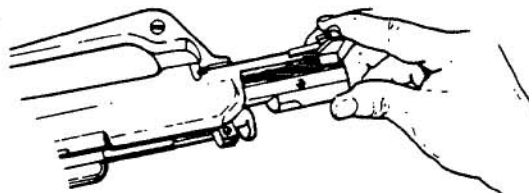

Step 2. Check for improperly assembled bolt adapter assembly and worn, broken, or missing parts.
Replace worn, broken, or missing parts; assemble correctly (p 3-6).

5. HAS SHORT RECOIL

Check for restricted movement of bolt adapter assembly.
See step 1 of malfunction 4, FAILS TO LOCK.

- b. This manual cannot list all possible malfunctions that may occur, nor all tests or inspections and corrective actions. If a malfunction is not listed (except when malfunctions and cause are obvious), or is not corrected by listed corrective actions, notify your supervisor.

NOTE

When substandard, corroded, or damaged caliber .22 ammunition is used, malfunctions listed in troubleshooting table will occur.

- c. For troubleshooting procedures for M16 and M16A1 rifles, refer to TM 9-1005-249-20.

Section V. ORGANIZATIONAL MAINTENANCE INSTRUCTIONS

4-8. BOLT ADAPTER ASSEMBLY.

This task covers:

- | | |
|------------------------|-------------|
| a. Disassembly | c. Repair |
| b. Cleaning/inspection | d. Assembly |

INITIAL SETUP

Applicable Configuration

All

Test Equipment, Special Tools

Materials/Parts

Bore Brush

Rags

Cleaner, Lubricant and
Preservative (CLP)

References

None

Troubleshooting References

Page 4-2 of this manual

Equipment Condition

Assembled

Special Safety Instructions

Make certain there
is no ammunition in
the adapter.

Approximate Time Required

See MAC (app C)

LOCATION	ITEM	ACTION	REMARKS
----------	------	--------	---------

DISASSEMBLYBolt Adapter
AssemblyBarrel, guide
rail, and rail
support group (1)
Bolt (2)
Spring (3)
Straight pin (4)

Disassemble.

Refer to page 3-5.

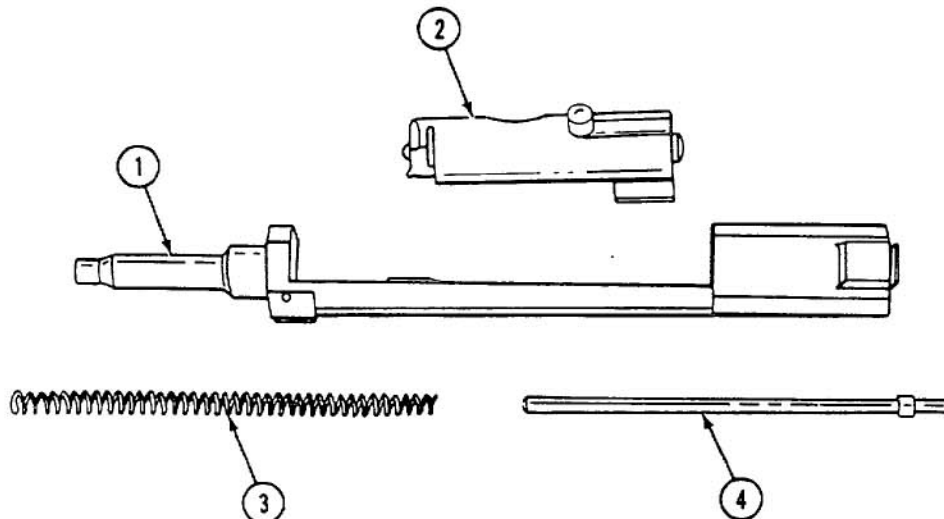

LOCATION	ITEM	ACTION	REMARKS
Barrel, Guide Rail and Rail Support Group	Barrel retaining pin (5) Barrel (6) Guide rail and support group (7)	Disassemble.	Use hammer and punch to remove barrel retaining pin.

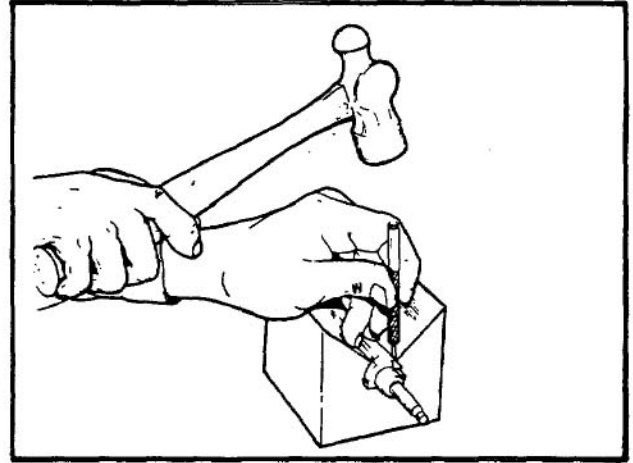
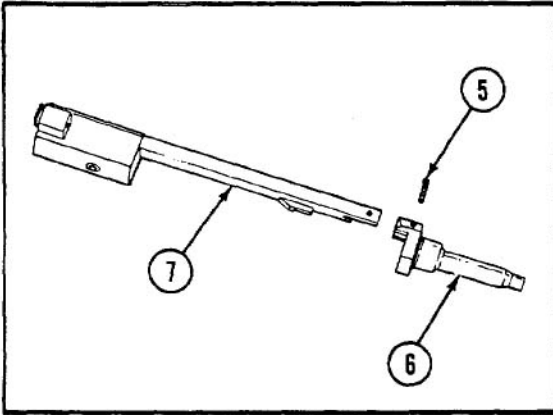

Guide Rail and Support Group	Retaining screw (8) Position spring (9) Support lug (10) Guide rail and support (11)	Disassemble.	Use socket head screw key to remove retaining screw (8).
------------------------------	---	--------------	--

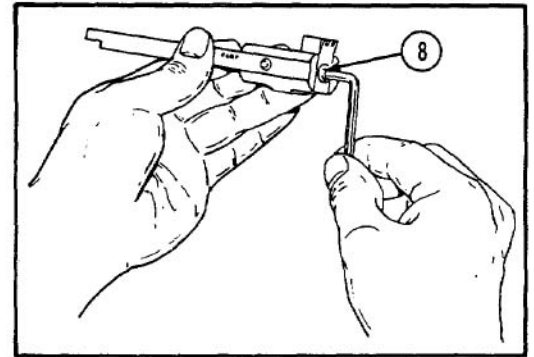
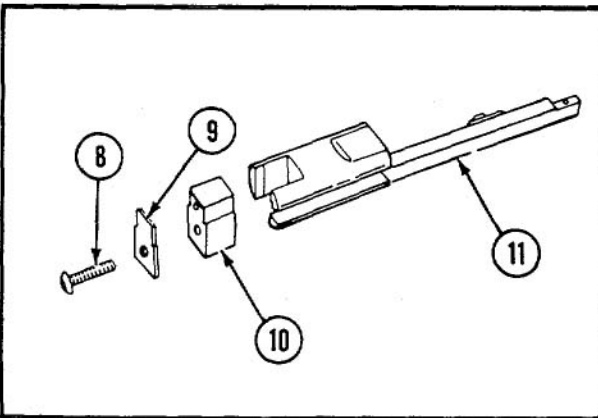

4-8. BOLT ADAPTER ASSEMBLY (CONT).

DISASSEMBLY (CONT)

Guide Rail
and Support

Cap screw (12)
Rail support (13)
Guide rail (14)

Disassemble.

Use socket head screw
key to remove cap
screw (12).

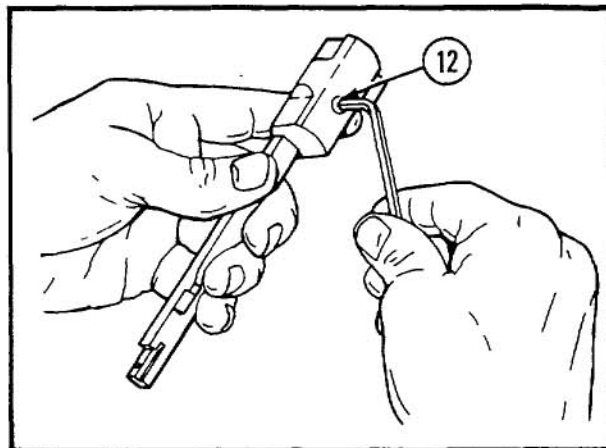
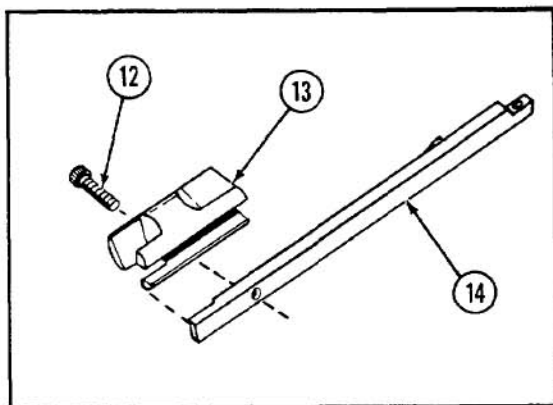

Bolt Group

Headless
straight pin (15)
Firing pin (16)
Firing pin
spring (17)
Straight pin (18)
Bolt body (19)

Disassemble.

Push in on firing pin
and push out headless
straight pin.

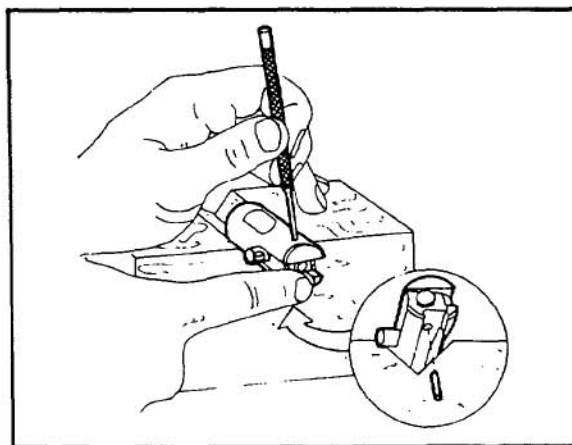
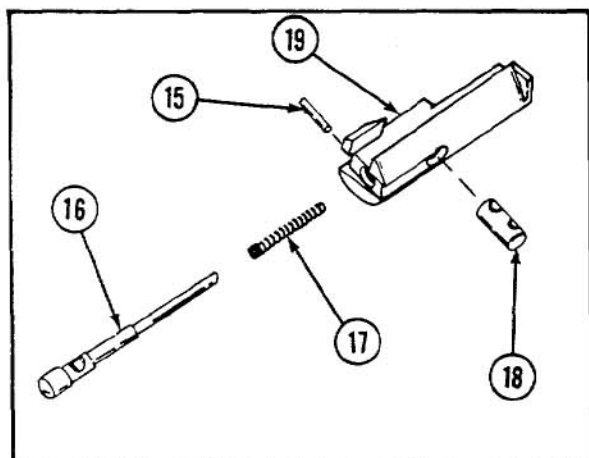

LOCATION	ITEM	ACTION	REMARKS
Bolt Body	Cartridge retainer (20) Extractor (21) Extractor plunger (22) Extractor spring (23) Bolt (24)	Disassemble.	Push up on cartridge retainer to remove.

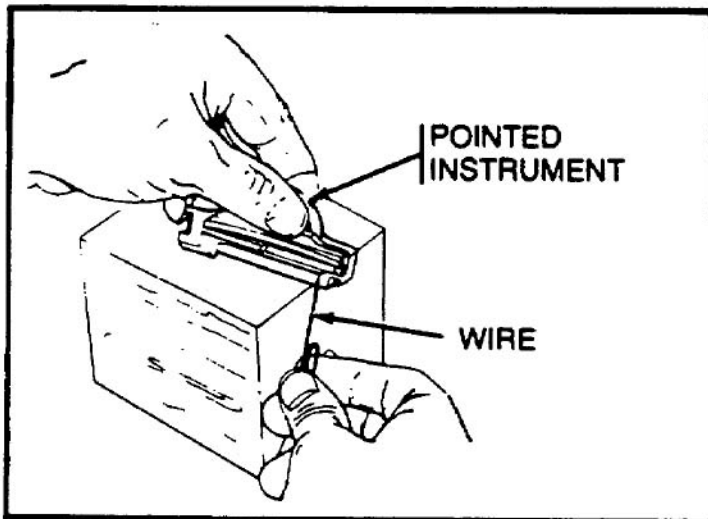
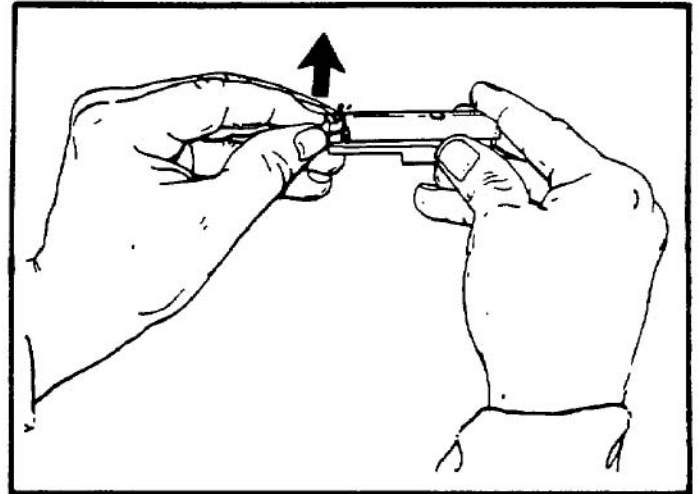
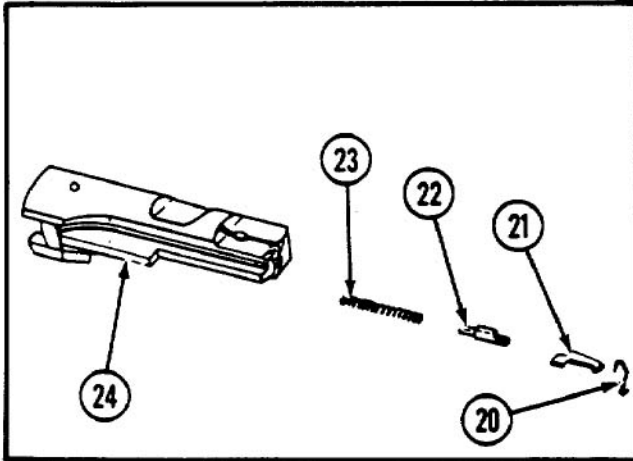

Use a pointed instrument to depress extractor spring and extractor plunger.

Use a wire to disengage extractor.

4-8. BOLT ADAPTER ASSEMBLY (CONT).

LOCATION	ITEM	ACTION	REMARKS
CLEANING/INSPECTION			
	Bolt Adapter Assembly	(1) Using a small bore brush dipped in CLP (item 4, app F), remove carbon deposits, corrosion, and dirt from all parts. After cleaning, wipe all parts dry with clean swabs (item 10, app F) or rags (item 9, app F). (2) Inspect all parts for serviceability. (3) Prior to assembly, coat all parts with a light film of CLP (item 4, app F).	
REPAIR			
	Bolt Adapter Assembly	Replace all unserviceable authorized parts.	Shorten retainer screw (see p 4-5, item 8) to thread length of 3/4 in.

REASSEMBLY**WARNING**

Positioning the cartridge retainer on the bolt face properly is vital for safe conversion kit performance. A damaged or improperly positioned cartridge retainer will cause a cartridge to fire out of battery, possibly causing injury to the shooter and bystanders, or result in a high malfunction rate.

Bolt Body	Bolt (1) Extractor spring (2) Extractor plunger (3) Extractor (4) Cartridge retainer (5)	Assemble.	Slide cartridge retainer down to install.
-----------	--	-----------	---

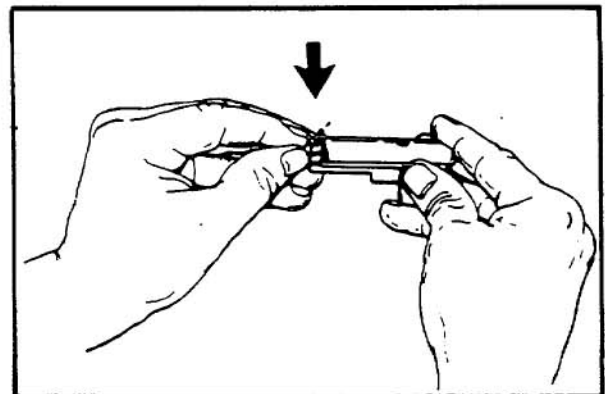
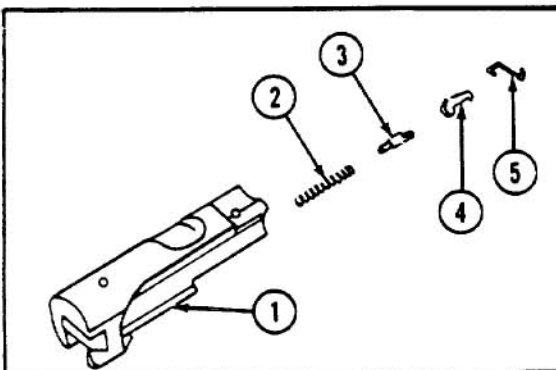

LOCATION**ITEM****ACTION****REMARKS**

Bolt Assembly

Bolt Body (6)
 Straight pin (7)
 Firing pin spring (8)
 Firing pin (9)
 Headless straight
 pin (10)

Assemble.

Push in and turn firing
 pin (9) until the slot
 is aligned with the pin
 hole, then install
 straight pin (10).

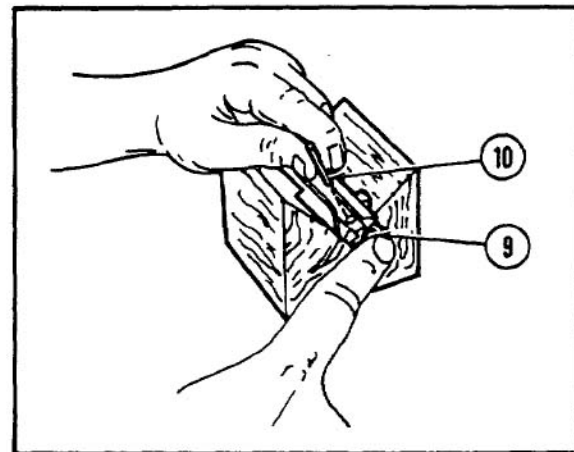
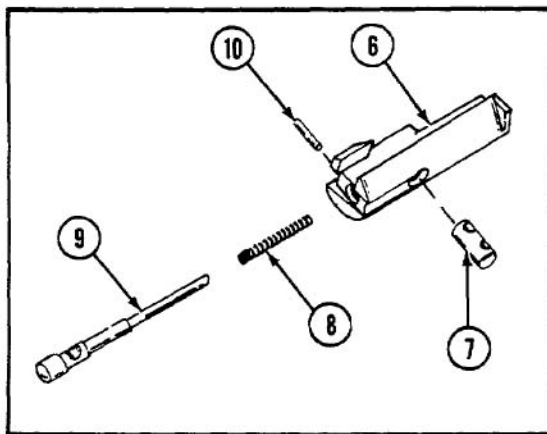
Guide Rail
and Support

Guide rail (11)
 Rail support (12)
 Cap screw (13)

Assemble.

Use socket head screw
 key to install cap
 screw (13).

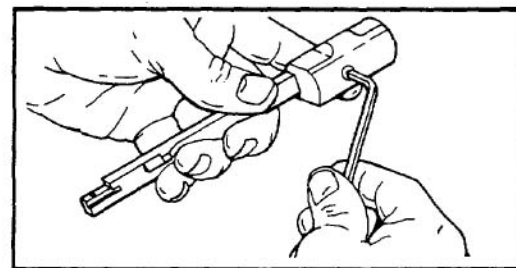
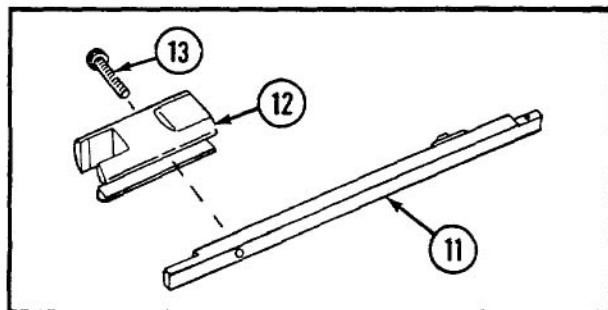

4-8. BOLT ADAPTER ASSEMBLY (CONT).

LOCATION	ITEM	ACTION	REMARKS
----------	------	--------	---------

REASSEMBLY (CONT)

Guide Rail
and Support Group

Guide rail and
support (14)
Support lug (15)
Position spring (16)
Retaining screw (17)

Assemble.

Use socket head screw
key to install retaining
screw.

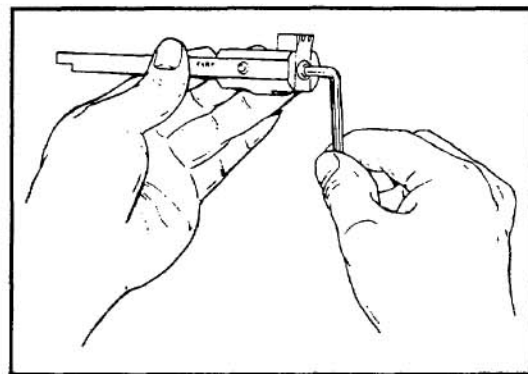
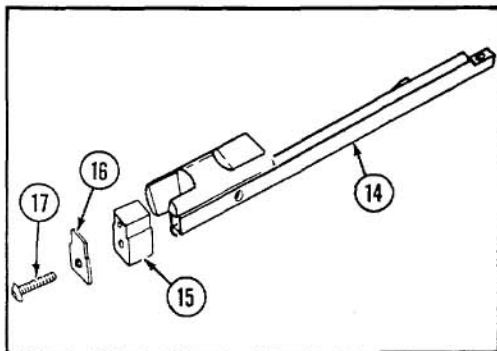

Barrel, Guide
Rail and Rail
Support Group

Guide rail and
support group (18)
Barrel (19)
Barrel retaining
pin (20)

Assemble.

Use hammer and punch to
install barrel retaining
pin.

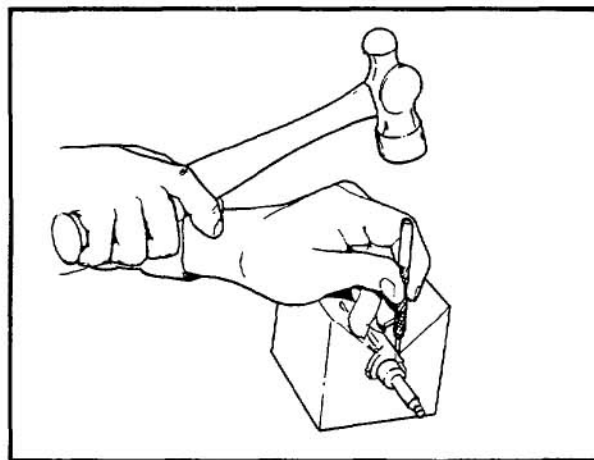
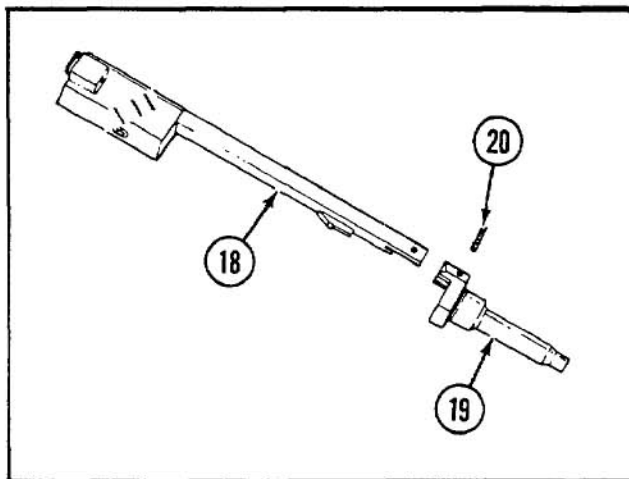

LOCATION	ITEM	ACTION	REMARKS
Bolt Adapter Assembly	Barrel, guide rail, and rail support group (21) Straight pin (22) Spring (23) Bolt assembly (24)	Assemble.	Refer to page 3-6.

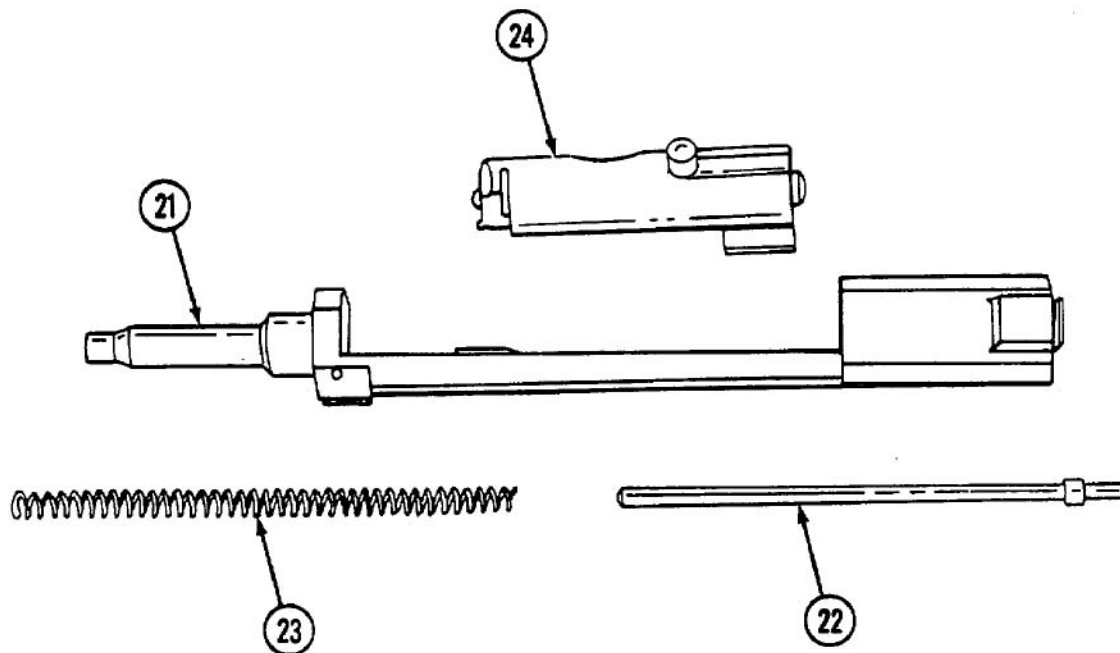

APPENDIX A REFERENCES

A-1. GENERAL. Consult the following publications frequently for the latest changes or revisions of references and for new publications relating to material covered in this manual.

A-2. OTHER PUBLICATIONS.

SB 708-41/42---	Federal Supply Code for Manufacturers - United States and Canada name to code and code to name
SC 4933-95-CL-A07	Tool Kit, Small Arms Repairman
TM 38-750	The Army Maintenance Management System (TAMMS)
TM 740-90-1	Administrative Storage of Equipment
TM 9-1005-249-10	Operator's Manual: M16A1 Rifle
TM 9-1005249-20	Organizational Maintenance Manual Including Repair Parts and Special Tools Lists: Rifle, 5.56-MM, M16A1, w/e (1005-00-073-9421); Rifle, 5.56-MM, M16 (1005-00-856-6885) Bipod, Rifle, M3 w/Carrying Case (1005-00-890-2609)
TM 9-1300-206	Ammunition and Explosives Standards

APPENDIX B COMPONENTS OF END ITEM LIST

Section I. INTRODUCTION

B-1. SCOPE. This appendix lists integral components of and basic issue items for the conversion kit to help you inventory items required for safe and efficient operation.

B-2. GENERAL. This Components of End Item List is divided into the following sections:

- a. *Section II.* Integral Components of the End Item. These items, when assembled, comprise the conversion kit and must accompany it whenever it is transferred or turned in. The illustrations will help you identify these items.
- b. *Section III.* Basic Issue Items. These are the minimum essential items required to place the conversion kit in operation, to operate it, and to perform emergency repairs. Although shipped separately packed they must accompany the conversion kit during operation and whenever it is transferred between accountable officers. The illustrations will assist you with hard-to-identify items. This manual is your authority to requisition replacement BII, based on TOE/MTOE authorization of the end item.

B-3. EXPLANATION OF COLUMNS.

- a. *Illustration.* This column is divided as follows:
 - (1) *Figure Number.* Indicates the figure number of the illustration on which the item is shown.

- (2) *Item Number.* The number used to identify item called out in the illustration.

- b. *National Stock Number.* Indicates the National stock number assigned to the item and which will be used for requisitioning.
- c. *Part Number.* Indicates the primary number used by the manufacturer, which controls the design and characteristics of the item by means of its engineering drawings, specifications, standards, and inspection requirements to identify an item or range of items.
- d. *Description.* Indicates the Federal item name and, if required, a minimum description to identify the item.
- e. *Location.* The physical location of each item listed is given in this column. The lists are designed to inventory all items in one area of the major item before moving on to an adjacent area.
- f. *Usable on Code.* Not applicable.
- g. *Quantity Required (Qty Req'd).* This column lists the quantity of each item required for a complete major item.
- h. *Quantity.* This column is left blank for use during and inventory. Under the Rcv'd column, list the quantity you actually receive on your major item. The Date columns are for your use when you inventory the major item at a later date; such as for shipment to another site.

Section II INTEGRAL COMPONENTS OF END ITEM

(1) Illustration		(2) National Stock Number	(3) Part No.	(4) Description	(5) Location	(6) Usable On Code	(7) Qty Reqd	(8) Quantity			
(a) Figure No.	(b) Item No.							Rev'd	Date	Date	Date
				None authorized							

Section III. BASIC ISSUE ITEMS

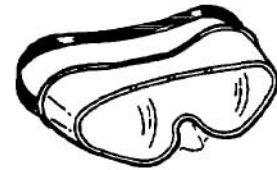
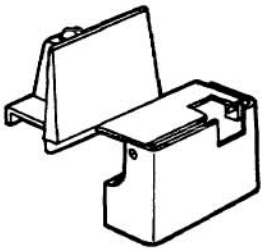

Figure B-1. Basic issue items.

(1) Illustration		(2) National Stock Number	(3) Part No.	(4) Description	(5) Location	(6) Usable On Code	(7) Qty Reqd	(8) Quantity			
(a) Figure No.	(b) Item No.							Rcv'd	Date	Date	Date
B-1	1	1005-01- 171-4778	9378328	Brass Deflector, Rimfire			1				
B-1	2	4240-00 052-3776	A-A-1110	Goggles, Industrial			2				

APPENDIX C MAINTENANCE ALLOCATION CHART

Section I. INTRODUCTION

C-1. GENERAL.

- a. This section provides a general explanation of all maintenance and repair functions authorized at various maintenance categories.
- b. The Maintenance Allocation Chart (MAC) in section II designates overall responsibility for the performance of maintenance functions on the identified end item or component. The implementation of the maintenance functions upon the end item or component will be consistent with the assigned maintenance functions.
- c. Section III lists the special tools and test equipment required for each maintenance function as referenced from section II.
- d. Section IV contains supplemental instructions and explanatory notes for a particular maintenance function.

C-2. MAINTENANCE FUNCTIONS. Maintenance functions will be limited to and defined as follows: (except for ammunition MAC1).

- a. *Inspect.* To determine the serviceability of an item by comparing its physical, mechanical, and/or electrical characteristics with established standards through examination.
- b. *Test.* To verify serviceability by measuring the mechanical or electrical characteristics of an item and comparing those characteristics with prescribed standards.
- c. *Service.* Operations required periodically to keep an item in proper operating condition, i.e., to clean (includes decontaminate, when required), to preserve, to drain, to paint, or to

replenish fuel, lubricants, chemical fluids, or gases.

- d. *Adjust.* To maintain, within prescribed limits, by bringing into proper or exact position, or by setting the operating characteristics to specified parameters.
- e. *Aline.* To adjust specified variable elements of an item to bring about optimum or desired performance.
- f. *Calibrate.* To determine and cause corrections to be made or to be adjusted on instruments or test, measuring, and diagnostic equipments used in precision measurement. Consists of comparisons of two instruments, one of which is a certified standard of known accuracy, to detect and adjust any discrepancy in the accuracy of the instrument being compared.
- g. *Install.* The act of emplacing, seating, or fixing into position an item, part, or module (component or assembly) in a manner to allow the proper functioning of an equipment or system.
- h. *Replace.* The act of substituting a serviceable like type part, subassembly, or module (component or assembly) for an unserviceable counterpart.
- i. *Repair.* The application of maintenance services² or other maintenance actions³ to restore serviceability to an item by correcting specific damage, fault, malfunction, or failure in a part, subassembly, module (component or assembly), end item, or system.

¹Exception is authorized for ammunition MAC to permit the redesignation/redefinition of maintenance function headings to more adequately identify ammunition maintenance functions. The heading designations and definitions will be included in the appropriate technical manual for each category of ammunition.

²Services - inspect, test, service, adjust, aline, calibrate, or replace.

³Actions - welding, grinding, riveting, straightening, facing, remachining, or resurfacing.

- j. *Overhaul.* That maintenance effort (service/action) necessary to restore an item to a completely serviceable/operational condition as prescribed by maintenance standards in appropriate technical publications (i.e., DMWR). Overhaul is normally the highest degree of maintenance performed by the Army. Overhaul does not normally return an item to like new condition.
- k. *Rebuild.* Consists of these services/actions necessary for the restoration of unserviceable equipment to a like new condition in accordance with original manufacturing standards. Rebuild is the highest degree of materiel maintenance applied to Army equipment. The rebuild operation includes the act of returning to zero those age measurements (hours/miles, etc.) considered in classifying Army equipments/components.

includes preparation time, troubleshooting time, and quality assurance/quality control time in addition to the time required to perform the specific tasks identified for the maintenance functions authorized in the maintenance allocation chart. The symbol designations for the various maintenance categories are as follows:

- C..... Operator or crew.
- O Organizational maintenance.
- F Direct support maintenance.
- H..... General support maintenance.
- D..... Depot maintenance.

- e. *Column 5, Tools and Equipment.* Column 5 specifies, by code, those common tool sets (not individual tools) and special tools, TMDE, and support equipment required to perform the designated function.
- f. *Column 6, Remarks.* This column shall, when applicable, contain a letter code, in alphabetic order, which shall be keyed to the remarks contained in Section IV.

C-3. EXPLANATION OF COLUMNS IN THE MAC, Section II.

- a. *Column 1, Group Number.* Column 1 lists functional group code numbers, the purpose of which is to identify components, assemblies, subassemblies, and modules with the next higher assembly.
- b. *Column 2, Component/Assembly.* Column 2 contains the names of components, assemblies, subassemblies, and modules for which maintenance is authorized.
- c. *Column 3, Maintenance Functions.* Column 3 lists the functions to be performed on the item listed in Column 2. (For detailed explanation of these functions, see paragraph C-2.)
- d. *Column 4, Maintenance Category.* Column 4 specifies, by the listing of a work time figure in the appropriate subcolumn(s), the category of maintenance authorized to perform the function listed in Column 3. This figure represents the active time required to perform that maintenance function at the indicated category of maintenance. If the number of complexity of the tasks within the listed maintenance function vary at different maintenance categories, appropriate work time figures will be shown for each category. The work time figure represents the average time required to restore an item (assembly, subassembly, component, module, end item, or system) to a serviceable condition under typical field operating conditions. This time

C-4. EXPLANATION OF COLUMNS IN TOOL AND TEST EQUIPMENT REQUIREMENTS, Section III.

- a. *Column 1, Reference Code.* The tool and test equipment reference code correlates with a code used in the MAC, Section II, Column 5.
- b. *Column 2, Maintenance Category.* The lowest category of maintenance authorized to use the tool or test equipment.
- c. *Column 3, Nomenclature.* Name or identification of the tool or test equipment.
- d. *Column 4, National Stock Number.* The National stock number of the tools or test equipment.
- e. *Column 5, Tool Part Number.* The manufacturer's part number.

C-5. EXPLANATION OF COLUMNS IN REMARKS, SECTION IV.

- a. *Column 1, Reference Code.* The code recorded in column 6, Section II.
- b. *Column 2, Remarks.* This column lists information pertinent to the maintenance function being performed as indicated in the MAC, Section II.

Section II. MAINTENANCE ALLOCATION CHART

(1) GROUP NUMBER	(2) COMPONENT/ ASSEMBLY	(3) MAINTENANCE FUNCTION	(4) MAINTENANCE LEVEL					(5) TOOLS AND EQUIPMENT	(6) REMARKS
			C	O	F	H	D		
00	Conversion Kit	Inspect Repair Replace		0.1 0.3					
01	Bolt Adapter Assembly	Inspect Service Install	0.1 0.1 0.1						
02	Magazine Adapter Assembly	Repair Inspect Service Install Replace		0.3			1		

Section III. TOOLS AND EQUIPMENT REQUIREMENTS

(1) REFERENCE CODE	(2) MAINTENANCE LEVEL	(3) NOMENCLATURE	(4) NATIONAL STOCK NUMBER	(5) TOOL PART NUMBER
1	0	Tool Kit, Small Arms Repairman	4933-00-357-7770	SC5180-95-CL-A07

Section IV. REMARKS

REFERENCE CODE	REMARKS
	None

**APPENDIX D
OPERATOR AND ORGANIZATIONAL MAINTENANCE REPAIR PARTS
AND SPECIAL TOOLS LIST**

Section I. INTRODUCTION

D-1. SCOPE. This manual lists spares and repair parts; special tools; special test, measurement, and diagnostic equipment (TMDE), and other special support equipment required for performance of operator and organizational maintenance of the conversion kit. (Caliber .22 rimfire adapter) for 5.56-mm M16 and M16A1 rifle. It authorizes the requisitioning and issue of spares and repair parts as indicated by the source and maintenance codes.

D-2. GENERAL. This Repair Parts and Special Tools List is divided into the following sections:

- a. *Section II.* Repair Parts List. A list of spares and repair parts authorized for use in the performance of maintenance. The list also includes parts which must be removed for replacement of the authorized parts. Parts lists are composed of functional groups in numeric sequence, with the parts in each group listed in figure and item number sequence. Bulk materials are listed in NSN sequence.
- b. *Section III.* Special Tools List. A list of special tools, special TMDE, and other special support equipment authorized for the performance of maintenance.
- c. *Section IV.* National Stock Number and Part Number Index. A list, in National item identification number (NIIN) sequence, of all National stock numbers (NSN) appearing in the listings, followed by a list in alphanumeric sequence of all part numbers appearing in the listings. National stock numbers and part numbers are cross-referenced to each illustration figure and item number appearance. This index is followed by a cross-reference list of reference designators to figure and item numbers.

(2) *Item number.* The number used to identify item called out in the illustration.

b. *Source, Maintenance, and Recoverability (SMR) Codes.*

(1) *Source code.* Source codes indicate the manner of acquiring support items for maintenance, repair, or overhaul of end items. Source codes are entered in the first and second positions of the Uniform SMR Code format as follows:

<i>Code</i>	<i>Definition</i>
PA	Item procured and stocked for anticipated or known usage.
PB	Item procured and stocked for insurance purposes because essentiality dictates that a minimum quantity be available in the supply system.
PC	Item procured and stocked and which otherwise would be coded PA except that it is deteriorative in nature.
PD	Support item, excluding support equipment, procured for initial issue or outfitting and stocked only for subsequent or additional initial issues or outfittings. Not subject to automatic replenishment.
PE	Support equipment procured and stocked for initial issue or outfitting to specified maintenance repair activities.
PF	Support equipment which will not be stocked but which will be centrally procured on demand.
PG	Item procured and stocked to provide for sustained support for the life of the equipment. It is applied to an item peculiar to the equipment which, because of probable discontinuance or shutdown of production facilities, would prove uneconomical to reproduce at a later time.

D-3. EXPLANATION OF COLUMNS.

- a. *Illustration.* This column is divided as follows:
 - (1) *Figure number.* Indicates the figure number of the illustration on which the item is shown.

<i>Code</i>	<i>Definition</i>
KD.....	An item of a depot overhaul/repair kit and not purchased separately. Depot kit defined as a kit that provides items required at the time of overhaul or repair.
KF.....	An item of a maintenance kit and not purchased separately. Maintenance kit defined as a kit that provides an item that can be replaced at organizational or intermediate levels of maintenance.
KB.....	Item included in both a depot overhaul/repair kit and a maintenance kit.
MO.....	Item to be manufactured or fabricated at organizational level.
MF.....	Item to be manufactured or fabricated at the direct support maintenance level.
MH.....	Item to be manufactured or fabricated at the general support maintenance level.
MD.....	Item to be manufactured or fabricated at the depot maintenance level.
AO.....	Item to be assembled at organizational level.
AF.....	Item to be assembled at direct support maintenance level.
AH.....	Item to be assembled at general support maintenance level.
AD.....	Item to be assembled at depot maintenance level.
XA.....	Item is not procured or stocked because the requirements for the item will result in the replacement of the next higher assembly.
XB.....	Item is not procured or stocked. If not available through salvage, requisition.
XC.....	Installation drawing, diagram, instruction sheet, field service drawing that is identified by manufacturer's part number.
XD.....	A support item that is not stocked. When required, item will be procured through normal supply channels.

NOTE

Cannibalization or salvage may be used as a source of supply for any items coded above except those coded XA and aircraft support items as restricted by AR 700-42.

(2) *Maintenance code.* Maintenance codes are

assigned to indicate the levels of maintenance authorized to USE and REPAIR support items. The maintenance codes are entered in the third and fourth positions of Uniform SMR Code format as follows:

- (a) The maintenance code entered in the third position will indicate the lowest maintenance level authorized to remove, replace, and use the support item. The maintenance code entered in the third position will indicate one of the following levels of maintenance:

<i>Code</i>	<i>Application/Explanation</i>
C.....	Crew or operator maintenance performed within organizational maintenance.
O.....	Support item is removed, replaced, used at the organizational level.
F.....	Support item is removed, replaced, used at the direct support level.
H.....	Support item is removed, replaced, used at the general support level.
D.....	Support items that are removed, replaced, used at depot, mobile depot, or specialized repair activity only.

- (b) The maintenance code entered in the fourth position indicates whether the item is to be repaired and identifies the lowest maintenance level with the capability to perform complete repair (i.e., all authorized maintenance functions). This position will contain one of the following maintenance codes.

<i>Code</i>	<i>Application/Explanation</i>
O.....	The lowest maintenance level capable of complete repair of the support item is the organizational level.
F.....	The lowest maintenance level capable of complete repair of the support item is the direct support level.
H.....	The lowest maintenance level capable of complete repair of the support item is the general support level.
D.....	The lowest maintenance level capable of complete repair of the support item is the depot level.

<i>Code</i>	<i>Application/Explanation</i>
L.....	Repair restricted to Specialized Repair Activity.
Z.....	Nonreparable. No repair is authorized.
B.....	No repair is authorized. The item may be reconditioned by adjusting, lubricating, etc, at the user level. No parts or special tools are procured for the maintenance of this item.

(3) *Recoverability code.* Recoverability codes are assigned to support items to indicate the disposition action on unserviceable items. The recoverability code is entered in the fifth position of the Uniform SMR Code format as follows:

Recoverability

<i>Codes</i>	<i>Definition</i>
Z.....	Nonreparable item. When unserviceable, condemn and dispose at the level indicated in position 3.
0.....	Reparable item. When uneconomically repairable, condemn and dispose at organizational level.
F.....	Reparable item. When uneconomically repairable, condemn and dispose at the direct support level.
H.....	Reparable item. When uneconomically repairable, condemn and dispose at the general support level.
D.....	Reparable item. When beyond lower level repair capability, return to depot. Condemnation and disposal not authorized below depot level.
L.....	Reparable item. Repair, condemnation, and disposal not authorized below depot/specialized repair activity level.
A.....	Item requires special handling or condemnation procedures because of specific reasons (i.e., precious metal content, high dollar value, critical material, or hazardous material). Refer to appropriate manuals/directives for specific instructions.

c. *National Stock Number.* Indicates the National stock number assigned to the item and which will be used for requisitioning.

d. *Federal Supply Code for Manufacturer*

(FSCM). The FSCM is a 5-digit numeric code listed in SB 708-41/42 which is used to identify the manufacturer, distributor, or Government agency, etc.

NOTE

When a stock numbered item is requisitioned, the item received may have a different part number than the part being replaced.

e. *Part Number.* Indicates the primary number used by the manufacturer (individual, company, firm, corporation, or Government activity), which controls the design and characteristics of the item by means of its engineering drawings, specifications, standards, and inspection requirements to identify an item or range of items.

f. *Description.* Indicates the Federal item name and, if required, a minimum description to identify the item. In the Special Tools List, the initial basis of issue (BOI) appears as the last line in the entry for each special tool, special TMDE, and other special support equipment. When density of equipments supported exceeds density spread indicated in the basis of issue, the total authorization is increased accordingly.

g. *Unit of Measure (U/M).* Indicates the standard of the basic quantity of the listed item as used in performing the actual maintenance function. This measure is expressed by a two-character alphabetical abbreviation (e.g., ea, in., pr, etc). When the unit of measure differs from the unit of issue, the lowest unit of issue that will satisfy the required units of measure will be requisitioned.

h. *Quantity Incorporated in Unit.* Indicates the quantity of the item used in the breakout shown on the illustration figure, which is prepared for a functional group, subfunctional group, or an assembly. A "V" appearing in this column in lieu of a quantity indicates that no specific quantity is applicable, (e.g., shims, spacers, etc).

D-4. SPECIAL INFORMATION. Not applicable.

D-5. HOW TO LOCATE REPAIR PARTS.

a. When National Stock Number or Part Number is Unknown.

- (1) *First.* Using the table of contents, determine the functional group or subgroup within which the item belongs. This is necessary since illustrations are prepared for functional groups or subgroups, and listings are divided into the same groups.
- (2) *Second.* Find the illustration covering the functional group or subgroup to which the item belongs.
- (3) *Third.* Identify the item on the illustration and note the illustration figure and item number of the item.

(4) *Fourth.* Using the Repair Parts Listing, find the figure and item number noted on the illustration.

b. When National Stock Number or Part Number is Known.

- (1) *First.* Using the Index of National Stock Numbers and Part Numbers, find the pertinent National stock number or part number. This index is in NIIN sequence followed by a list of part numbers in alphanumeric sequence, cross-referenced to the illustration figure number and item number.
- (2) *Second.* After finding the figure and item number, locate the figure and item number in the repair parts list.

D-6. ABBREVIATIONS. Not applicable.

Section II. REPAIR PARTS LIST

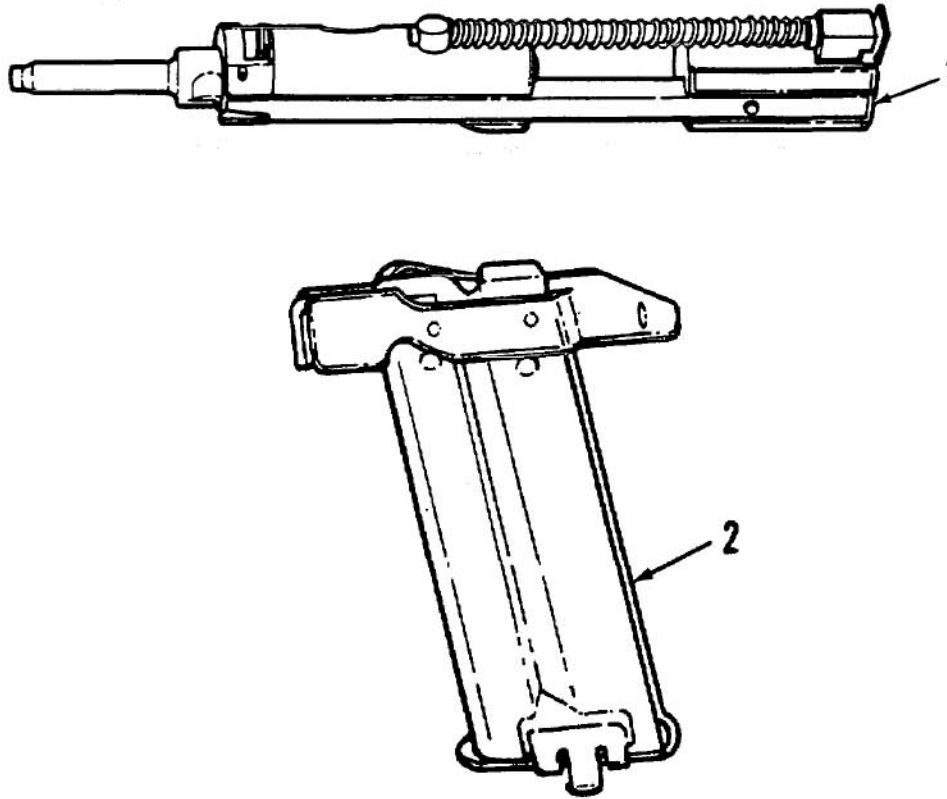

Figure D-1. Conversion kit 12003060

(1) ILLUSTRATION		(2)	(3)	(4)	(5)	(6) DESCRIPTION	(7)	(8)
(a) FIG NO.	(b) ITEM NO.	SMR CODE	NATIONAL STOCK NUMBER	FSCM	PART NUMBER	USABLE ON CODE	U/M	QTY INC IN UNIT
GROUP 00 CONVERSION KIT 12003060								
D-1	1	XAOOO		19204	12003080	BOLT, ADAPTER, ASSY	EA	1
D-1	2	PAOZZ	1005-01-075-5001	19204	12003091	MAGAZINE, CARTRIDGE	EA	1

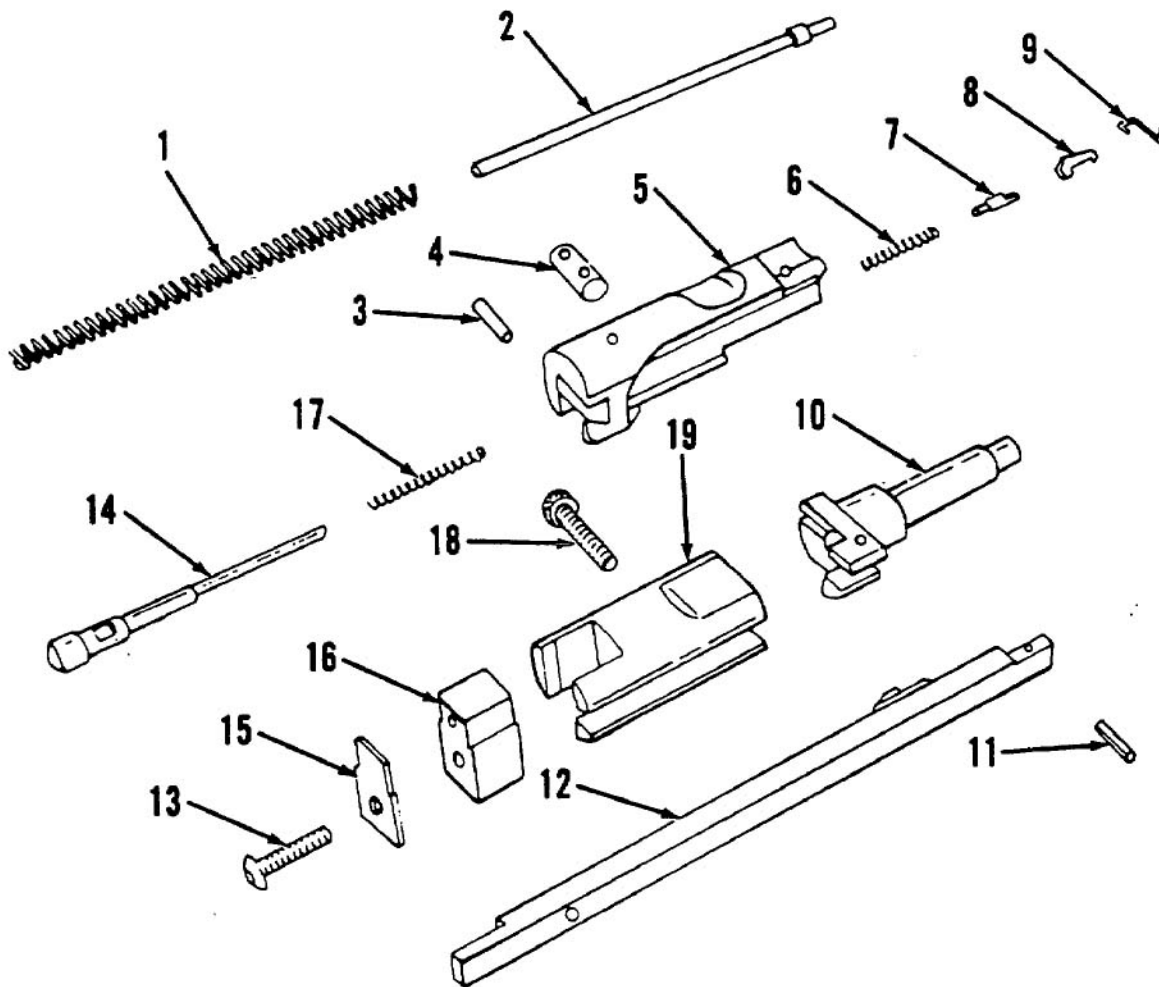

Figure D-2. Bolt adapter assembly 12003080

(1) ILLUSTRATION		(2)	(3)	(4)	(5)	(6) DESCRIPTION	(7)	(8)
(a) FIG NO.	(b) ITEM NO.	SMR CODE	NATIONAL STOCK NUMBER	FSCM	PART NUMBER	USABLE ON CODE	U/M	QTY INC IN UNIT
						GROUP 01 BOLT ADAPTER ASSEMBLY		
						12003080		
D-2	1	PAOZZ	5360-01-040-3666	19204	12003068	SPRING, HELICAL, COMP.....	EA	1
D-2	2	PAOZZ	5315-01-039-9863	19204	12003066	PIN. SHOULDER. HEADLE.....	EA	1
D-2	3	PAOZZ	5315-00-811-9213	96906	MS16555-28	PIN. STRAIGHT, HEADLE.....	EA	1
D-2	4	PAOZZ	5315-01-040-0609	19204	12003071	PIN. STRAIGHT HEADLE.....	EA	1
D-2	5	XAOZZ		19204	12003075	BOLT.....	EA	1
D-2	6	PAOZZ	5301-01-040-3665	19204	12003072	SPRING HELICAL COMP.....	EA	1
D-2	7	PAOZZ	1005-01-148-4955	19204	12003073	PLUNGER. DETENT.....	EA	1
D-2	8	PAOZZ	1005-01-040-0043	19204	12003074	EXTRACTOR CARTRIDGE.....	EA	1
0-2	9	PAOZZ	1005-01-078-3905	19204	12003092	RETAINER CARTRIDGE.....	EA	1
D-2	10	XAOZZ		19204	12003079	BARREL.....	EA	1
D-2	11	PAOZZ	5315-00-812-3312	96906	M16562-119	PIN SPRING.....	EA	1
D-2	12	XAOZZ		19204	12003077	RAIL, GUIDE.....	EA	1
D-2	13	PAOZZ	5305-00-638-8859	81348	FF886	SCREW, CAP, SOCKET HE.....	EA	1
D-2	14	PAOZZ	1005-01-040-0894	19204	12003067	PIN. FIRING.....	EA	1
D-2	15	PAOZZ	5360-01-142-5341	19204	12003062	SPRING, FLAT.....	EA	1
D-2	16	XAOZZ		19204	12003063	LUG, SUPPORT.....	EA	1
D-2	17	PAOZZ	5360-01-040-3664	19204	12003069	SPRING, HELICAL, COMP.....	EA	1
D-2	18	PAOZZ	5305-00-469-6798	96906	MS16996-12B	SCREW, CAP, SOCKET HE.....	EA	1
D-2	19	XAOZZ		19204	12003065	SUPPORT, RAIL.....	EA	1

Section III. SPECIAL TOOLS LIST

(1) ILLUSTRATION		(2)	(3)	(4)	(5)	(6)	(7)	(8)
(a) FIG NO.	(b) ITEM NO.	SMR CODE	NATIONAL STOCK NUMBER	FSCM	PART NUMBER	USABLE ON CODE	U/M	QTY INC IN UNIT
						None authorized		

Section IV. NATIONAL STOCK NUMBER AND PART NUMBER INDEX

STOCK NUMBER	FIG. NO.	ITEM NO.	STOCK NUMBER	FIG. NO.	ITEM NO.
5305-00-469-6798	D-2	18	5360-01-040-3664	D-2	17
5305-00-638-8859	D-2	13	5360-01-040-3665	D-2	6
5315-00-811-9213	D-2	3	5360-01-040-3666	D-2	1
5315-00-812-3312	D-2	11	1005-01-075-5001	D-1	2
5315-01-039-9863	D-2	2	1005-01-078-3905	D-2	9
1005-01-040-0043	D-2	8	5360-01-142-5341	D-2	15
5315-01-040-0609	D-2	4	1005-01-148-4955	D-2	7
1005-01-040-0894	D-2	14			

FSCM	PART NUMBER	FIGURE NO.	ITEM NO.	FSCM	PART NUMBER	FIGURE NO.	ITEM NO.
81348	FFS86	D-2	13	19204	12003071	D-2	4
96906	MS16555-28	D-2	3	19204	12003072	D-2	6
96906	MS16562-119	D-2	11	19204	12003073	D-2	7
96906	MS916996-12B	D-2	18	19204	12003074	D-2	8
19204	12003062	D-2	15	19204	12003075	D-2	5
19204	12003063	D-2	16	19204	12003077	D-2	12
19204	12003065	D-2	19	19204	12003079	D-2	10
19204	12003066	D-2	2	19204	12003080	D-1	1
19204	12003067	D-2	14	19204	12003091	D-1	2
19204	12003068	D-2	1	19204	12003092	D-2	9
19204	12003069	D-2	17				

APPENDIX E
ADDITIONAL AUTHORIZATION LIST

Section I. INTRODUCTION

E-1. SCOPE. This appendix lists additional items you are authorized for the support of the conversion kit.

E-2. GENERAL. This list identifies items that do not have to accompany the conversion kit and that do not have to be turned in with it. These items are all authorized to you by CTA, MTOE, TDA, or JTA.

E-3. EXPLANATION OF LISTING. National stock numbers, descriptions, and quantities are provided to help you identify and request the additional items you require to support this equipment.

Section II. ADDITIONAL AUTHORIZATION LIST

(1) NATIONAL STOCK NUMBER	PART NUMBER & FSCM	(2) DESCRIPTION	USABLE ON CODE	(3) U/M	(4) QTY AUTH
		None authorized			

**APPENDIX F
EXPENDABLE SUPPLIES AND MATERIALS LIST**

Section I. INTRODUCTION

F-1. SCOPE. This appendix lists expendable supplies and materials you will need to operate and maintain the conversion kit. These items are authorized to you by CTA 50-970, Expendable Items (Except Medical, Class V, Repair Parts, and Heraldic Items).

F-2. EXPLANATION OF COLUMNS.

- a. Column 1 - Item Number.* This number is assigned to the entry in the listing and is referenced in the narrative instructions to identify the material (e.g., "Use cleaner, lubricant and preservative, item 4, app F").
- b. Column 2 - Level.* This column identifies the lowest level of maintenance that requires the listed item.

C - Operator/Crew

0 - Organizational Maintenance

- c. Column 3 - National Stock Number.* This is the National stock number assigned to the item; use it to request or requisition the item.
- d. Column 4 - Description.* Indicates the Federal item name and, if required, a description to identify the item. The last line for each item indicates the part number followed by the Federal Supply Code for Manufacturer (FSCM) in parentheses, if applicable.
- e. Column 5 - Unit of Measure (U/M).* Indicates the measure used in performing the actual maintenance function. This measure is expressed by a two-character alphabetical abbreviation (e.g., ea, in., pr). If the unit of measure differs from the unit of issue, requisition the lowest unit of issue that will satisfy your requirements.

Section II. EXPENDABLE SUPPLIES AND MATERIALS LIST

(1) ITEM NUMBER	(2) LEVEL	(3) NATIONAL STOCK NUMBER	(4) DESCRIPTION	(5) U/M
1	C	8020-00-244-0153	BRUSH, ARTIST'S: H-B-241 (81348)	EA
2	C	7920-00-205-2401	BRUSH, CLEANING, TOOLS AND PARTS: MS16746 (96906)	EA
3			Deleted	
4			CLEANER, LUBRICANT, and PRESERVATIVE: (27412)	
	C	9150-01-079-6124	CLP-4 4 oz btl	OZ
	O	9150-01-054-6453	CLP-5 pt btl	PT
	O	9150-01-053-6688	CLP-7 gal btl	GL
5	C		CLEANER, TOBACCO PIPE: (DILLS) 840507 (19203)	
		9920-00-292-9946	36 per pkg	PG

(1) ITEM NUMBER	(2) LEVEL	(3) NATIONAL STOCK NUMBER	(4) DESCRIPTION	(5) U/M
6	0	5350-00-221-0872	CLOTH ABRASIVE:	SH
7	0		A-A-1206 (58536) DRY CLEANING SOLVENT: (SD) P-D-680 (81348)	
7.1	0	6850-00-281-1985 8415-00-823-7456	1 gal can GLOVES, CHEMICAL AND OIL PROTECTIVE: ZZ-G-381 (81348)	GL PR
8	0		LUBRICANT, SOLID FILM MILL46147 (81349)	
9	0	9150-00168-2000	16 oz aerosol can RAG, WIPING: cotton A-A-531 (58536)	CN
10	C	7920-00-205-1711	50 lb bale SWAB, SMALL ARMS CLEANING: cotton 11686408 (19204)	LB
		1005-00-912-4248	1 pkg (1000 per pkg)	PG

By Order of the Secretary of the Army:

Official:

J. C. PENNINGTON
Major General, United States Army
The Adjutant General

E. C. MEYER
General United States Army
Chief of Staff

Distribution:

To be distributed in accordance with DA Form 12-40 Organizational Maintenance requirements for Rifle, 5.56-mm. M16. M16A1.

RECOMMENDED CHANGES TO EQUIPMENT TECHNICAL PUBLICATIONS



THEN... JOT DOWN THE DOPE ABOUT IT ON THIS FORM, CAREFULLY TEAR IT OUT, FOLD IT AND DROP IT IN THE MAIL!

SOMETHING WRONG WITH THIS PUBLICATION?

FROM: (PRINT YOUR UNIT'S COMPLETE ADDRESS)

DATE SENT

PUBLICATION NUMBER

PUBLICATION DATE

PUBLICATION TITLE

BE EXACT... PIN-POINT WHERE IT IS

PAGE NO	PARA-GRAPH	FIGURE NO	TABLE NO
---------	------------	-----------	----------

IN THIS SPACE TELL WHAT IS WRONG AND WHAT SHOULD BE DONE ABOUT IT:

TEAR ALONG PERFORATED LINE

PRINTED NAME, GRADE OR TITLE, AND TELEPHONE NUMBER

SIGN HERE:

PIN: 034244-000