

U.S. MARINE CORPS TECHNICAL MANUAL

**OPERATOR'S MANUAL
W/COMPONENTS LIST**

RIFLE, 5.56MM, M16A2 W/E, NSN 1005-01-128-9936
RIFLE, 5.56MM, M16A4 W/E, NSN 1005-01-357-2872
CARBINE, 5.56MM, M4 W/E, NSN 1005-01-231-0973
CARBINE, 5.56MM, M4A1 W/E, NSN 1005-01-382-0953



DISTRIBUTION D: DISTRIBUTION AUTHORIZED TO DOD AND DOD CONTRACTORS ONLY; PUBLICATION IS NOT TO BE RELEASED TO NON-DOD COMPONENTS. OTHER REQUESTS FOR THIS PUBLICATION MUST BE REFERRED TO: COMMANDER, MARINE CORPS SYSTEMS COMMAND (PGD-13) QUANTICO, VA 22134-6050.

DESTRUCTION NOTICE: DESTROY BY ANY METHOD THAT WOULD PREVENT DISCLOSURE OF CONTENTS OR RECONSTRUCTION OF THE DOCUMENTS.

FOR OFFICIAL USE ONLY NOV 2004

PCN 18405538000

"MY RIFLE"

The creed of a United States Marine

by

Maj. Gen. W.H. Rupertus, USMC

This is my rifle. There are many like it, but this one is mine.

My rifle is my best friend. It is my life. I must master it as I master my life.

My rifle, without me is useless. Without my rifle, I am useless. I must fire my rifle true. I must shoot straighter than my enemy who is trying to kill me. I must shoot him before he shoots me. I will...

My rifle and myself know that what counts in this war is not the rounds we fire, the noise of our burst, nor the smoke we make. We know that it is the hits that count. We will hit...

My rifle is human, even as I, because it is my life. Thus, I will learn it as a brother. I will learn its weaknesses, its strength, its parts, its accessories, its sights, and its barrel. I will ever guard it against the ravages of weather and damage. I will keep my rifle clean and ready, even as I am clean and ready. We will become part of each other. We will...

Before God I swear this creed. My rifle and myself are the defenders of my country. We are the masters of our enemy. We are the saviors of my life.

So be it, until victory is America's and there is no enemy, but Peace!

DEPARTMENT OF THE NAVY
Headquarters, U.S. Marine Corps
Washington, DC 20380-0001

30 November 2004

1. This Technical Manual (TM), authenticated for Marine Corps use and effective upon receipt, provides operational and maintenance instructions for the Rifle, 5.56MM, M16A2 W/E (1005-01-128-9936), Rifle, 5.56 MM, M16A4 W/E (1005-01-357-2872), Carbine, 5.56 MM, M4 W/E (1005-01-231-0973) and Carbine, 5.56 MM, M4A1 W/E (1005-01-382-0953).

2. Submit notice of discrepancies or suggested changes on a NAVMC 10772. The NAVMC may be submitted via the Internet using website <https://pubs.ala.usmc.mil/navmc/>, the NAVMC Tracking Program and following instructions provided. It may also be submitted via e-mail to: mbmatcommarlogbases@logcom.usmc.mil, or by mailing paper copy NAVMC 10772 in an envelop addressed to: Commander, Marine Corps Systems Command, Attn: Assistant Commander Acquisition and Logistics (LOG/TP), 814 Radford Blvd., Suite 20343 Albany, Georgia 31704-0343.

BY DIRECTION OF THE COMMANDANT OF THE MARINE CORPS

OFFICIAL:



M. J. MULLIGAN
Product Group Director, PGD-13
Marine Corps Systems Command

DISTRIBUTION: PCN 18405538000

LIST OF EFFECTIVE PAGES

NOTE: The portion of the text affected by the changes is indicated by a vertical line in the outer margins of the page. Changes to illustrations are indicated by miniature pointing hands. Changes to wiring diagrams are indicated by shaded areas.

Dates of issue for original and changed pages are:

Original 0 Nov 04

TOTAL NUMBER OF PAGES IN THIS PUBLICATION IS 196,
CONSISTING OF THE FOLLOWING:

Page No.*Change No.	Page No.*Change No.
Title 0	4-1 – 4-5 0
A 0	4-6 Blank 0
B Blank 0	A-1..... 0
i - xxi 0	A-2 Blank 0
xxii Blank 0	B-1 - B-21..... 0
1-1 - 1-14 0	B-22 Blank 0
2-1 - 2-44 0	C-1 - C-3..... 0
3-1 - 3-74 0	C-4 Blank 0

*Zero in this column indicates an original page.

CHANGE RECORD

Change No.	Date	Title of Brief Description	Entered By

TABLE OF CONTENTS

	<u>Page</u>
LIST OF ILLUSTRATIONS	viii
LIST OF TABLES	xii
SAFETY SUMMARY	xiii
CHAPTER I GENERAL INFORMATION AND SAFETY PRECAUTIONS	1-1
SECTION I. INTRODUCTION	1-1
1-1. Scope.....	1-1
a. Type of Manual.....	1-1
b. Equipment Name and Model Number	1-1
c. Procedures	1-1
1-2. Maintenance Forms and Procedures.....	1-2
1-3. Corrosion Prevention and Control (CPC)	1-2
1-4. Destruction of Material to Prevent Enemy Use	1-2
SECTION II. EQUIPMENT DESCRIPTION	1-3
1-5. General Description	1-3
1-6. Equipment Characteristics, Capabilities and Features	1-4
1-7. Location and Description of Major Components	1-8
1-8. Rail Adapter System (RAS) and Accessories.....	1-10
a. General.....	1-10
b. Rifle and Carbine	1-10
c. RAS Handguard Sections	1-11
1-9. M4A1 CQBW Carbine Quick Attach / Detach (QD) Sound Suppressor.....	1-13

TABLE OF CONTENTS (Continued)

	<u>Page</u>
CHAPTER 2 OPERATING INSTRUCTIONS.....	2-1
SECTION I. CONTROLS AND INDICATORS....	2-1
2-1. Operator Controls and Indicators.	2-1
a. Right View	2-1
b. Left View	2-4
2-2. Adjustable Front Sight Post	2-7
2-3. Adjustable Rear Sight	2-8
2-4. Selector Lever	2-9
a. SAFE	2-9
b. SEMI	2-9
c. BURST	2-10
d. AUTO (CQBW only)	2-10
SECTION II. OPERATING PROCEDURES.....	2-11
2-5. Loading Magazine	2-11
a. Using Magazine Filler	2-12
b. Loading for Semi-Auto Fire and Chambering a Round.....	2-13
c. Loading for a Three-Round Burst and Chambering a Round.....	2-15
2-6. M16A4 / M16A2 Rifle and M4 / M4A1 CQBW Carbine (36 yard) Zeroing.....	2-17
2-7. M16A4 Rifle and M4A1 CQBW Carbine Zeroing Procedures for a 300 Yard Battle Sight Zero	2-19
2-8. Special Infrared Aiming Light Zeroing Considerations.....	2-25
2-9. Clearing Weapon	2-27
2-10. Field Firing Techniques	2-30
2-11. Additional Information for Weapon Sights	2-33
2-12. Immediate Action	2-34

TABLE OF CONTENTS (Continued)

	<u>Page</u>
2-13. Remedial Action.....	2-36
2-14. Bullet Stuck In Bore.....	2-38
2-15. Operations Under Unusual Conditions	2-38
a. Extreme Cold Climate - Arctic	2-38
b. Hot, Wet Climate - Jungle ...	2-40
c. Hot, Dry Climate - Desert....	2-41
d. Heavy Rain and Fording Operations - All Climates	2-42
e. Nuclear, Biological and Chemical (NBC)	2-43
f. After Fording	2-43
CHAPTER 3 SCHEDULED MAINTENANCE	3-1
SECTION I. INTRODUCTION.....	3-1
3-1. General	3-1
SECTION II. DISASSEMBLY AND REASSEMBLY	3-2
3-2. Upper Receiver Disassembly	3-2
a. Clear the Weapon	3-2
b. Remove the Sling.....	3-2
c. Remove Handguards (M16A2).....	3-2
d. Separate Upper and Lower Receiver	3-4
e. Remove Carrying Handle Assembly (M16A4, M4, and M4A1 CQBW).....	3-6
f. Charging Handle and Bolt Carrier Disassembly.....	3-7

TABLE OF CONTENTS (Continued)

	<u>Page</u>
3-3. Bolt Carrier Disassembly.....	3-8
a. Firing Pin Removal.....	3-8
b. Extractor Removal.....	3-11
3-4. Lower Receiver Disassembly	3-13
a. Buffer Assembly Removal ...	3-13
b. Buttstock Removal – Carbine Only	3-14
3-5. Lower Receiver Reassembly	3-15
3-6. Bolt Carrier Reassembly	3-16
3-7. Upper Receiver Reassembly	3-20
3-8. Magazine.....	3-25
a. Disassembly	3-25
b. Inspection	3-27
c. Assembly.....	3-27
3-9. Rail Adapter Systems (RAS)	3-29
a. Disassembly of Handguards for Rifle and Carbine.....	3-29
b. Inspection	3-30
c. Assembly.....	3-31
3-10. RAS Accessory Mounting Procedures	3-33
a. Numbered Recoil Grooves ...	3-33
b. RAS	3-33
c. Standard Sling Adapter	3-33
3-11. Compensator	3-34
3-12. M15A2 / M23 Blank Firing Attachment (BFA)	3-35
3-13. Quick Attach / Detach (QD) Sound Suppressor	3-36
a. Disassembly	3-37
b. Inspection	3-38
c. Assembly.....	3-38
3-14. M4 / Model QD Sound Suppressor Maintenance	3-40

TABLE OF CONTENTS (Continued)

	<u>Page</u>
3-15. M4 / Model QD Sound Suppressor Cleaning.....	3-40
3-16. QD Sound Suppressor Lubrication	3-41
3-17. M203 Grenade Launcher / M16A4 Rifle / M4A1 CQBW Operational Notes.....	3-42
3-18. EO Tech Sight.....	3-43
a. Disassembly.....	3-43
b. Inspection.....	3-44
c. Assembly	3-44
3-19. Visible Light Illuminator (VLI)	3-44
a. Assembly	3-44
b. Inspection.....	3-45
c. Disassembly.....	3-45
SECTION III. SCHEDULED MAINTENANCE SERVICES.....	3-46
3-20. General Cleaning Information...	3-46
3-21. Field Expedient Cleaning	3-48
3-22. Detailed Cleaning Techniques ..	3-49
3-23. Thorough Cleaning.....	3-51
a. Upper Receiver	3-51
b. Bolt Carrier Group	3-54
c. Ejector.....	3-56
d. Carrier Key	3-58
e. Lower Receiver Group.....	3-58
f. Handguard	3-59
g. Front Sight	3-59
h. Compensator	3-59
i. Rear Sight	3-59
3-24. Inspect Before Lubricating	3-59
a. Bolt	3-59
b. Firing Pin Retaining Pin	3-59

TABLE OF CONTENTS (Continued)

	<u>Page</u>
c. Cam Pin.....	3-59
d. Firing Pin.....	3-60
e. Extractor and Extractor Spring	3-60
3-25. CLP – Cleaner, Lubricant and Preservative	3-60
3-26. Lubrication.....	3-61
a. Upper Receiver.....	3-61
b. M4A1 CQBW/ M16A4 Upper Receiver and Carrying Handle	3-62
c. Bolt Carrier Group	3-64
d. Lower Receiver Group	3-65
e. Adjustable Rear Sight.....	3-66
3-27. After Lubrication of Rear Sight.....	3-67
3-28. Lubrication After Amphibious Operations.....	3-68
3-29. Preventive Maintenance Checks and Services.....	3-68
a. General	3-68
b. Explanation of PMCS Table Columns and Entries	3-68
c. Other Table Entries	3-69
CHAPTER 4 TROUBLESHOOTING	4-1
4-1. Malfunctions.....	4-1
APPENDIX A REFERENCE PUBLICATIONS	A-1
A-1. Scope	A-1
A-2. Marine Corps Orders	A-1
A-3. Technical Manuals.....	A-1
A-4. Forms.....	A-1
A-5. Military Standards	A-1

TABLE OF CONTENTS (Continued)

	<u>Page</u>
APPENDIX B	LISTS OF COMPONENTSB-1
B-1.	Scope.....B-1
B-2.	Explanation of Columns.....B-1
a.	Item Number (Column 1)B-1
b.	Stock Number (Column 2).....B-1
c.	Reference Designator / Figure-Key (Column 3)B-1
d.	Item Identification / Model (Column 4).....B-2
e.	Unit of Measure (Column 5)..B-2
f.	Quantity Used in Unit (Column 6).....B-2
B-3.	Support Supply Categories.....B-2
a.	Supply System ResponsibilityB-2
b.	Collateral MaterialB-2
c.	Using Unit Responsibility.....B-2
B-4.	5th Echelon Rehabilitation Program.....B-3
B-5.	Request for Additional CopiesB-3
B-6.	Special Notes.....B-3
a.	Rifle, 5.56mm, M16A2.....B-3
b.	Rifle, 5.56mm, M16A4.....B-3
c.	Carbine, 5.56mm, M4.....B-3
d.	Carbine, 5.56mm, M4A1B-4
e.	Maintenance Forms and RecordsB-4
APPENDIX C	AMMUNITION.....C-1
C-1.	Using Tracer AmmunitionC-1
C-2.	Changing MagazinesC-1
C-3.	5.56mm AmmunitionC-2

LIST OF ILLUSTRATIONS

<u>Figure</u>	<u>Title</u>	<u>Page</u>
1-1.	Major Components – M16A2	1-9
1-2.	M16A4 with Removable Carrying Handle	1-9
1-3.	M4 / M4A1 with Collapsing Buttstock and with Removable Carrying Handle.....	1-9
1-4.	Rail Adapters - M16A2 / M16A4 Rifle	1-10
1-5.	Rail Adapters – M4 / M4A1 CQBW Carbine...	1-11
1-6.	Handguards	1-11
1-7.	Installation of Handguard Sections to RAS	1-12
1-8.	QD Sound Suppressor.....	1-13
1-9.	Compensators.....	1-14
2-1.	M16A2 - Right View	2-3
2-2.	M16A2 - Left View	2-5
2-3.	M4 / M4A1 CQBW Collapsible Buttstock Assembly	2-6
2-4.	Cleaning Kit Storage Area	2-6
2-5.	Adjustable Front Sight Post	2-7
2-6.	Adjustable Rear Sight	2-8
2-7.	Selector Lever - SAFE	2-9
2-8.	Selector Lever - SEMI	2-9
2-9.	Selector Lever - BURST	2-10
2-10.	M4A1 CQBW Only - Selector Lever - AUTO ..	2-10
2-11.	Stripper Clip and Magazine Filler.....	2-11
2-12.	Loading Magazine with Stripper Clip.....	2-12
2-13.	Seating the Magazine.....	2-13
2-14.	Bolt Catch	2-14
2-15.	Forward Assist	2-14
2-16.	Push Charging Handle Forward.....	2-16
2-17.	Bullet Trajectory	2-18
2-18.	Normal Range Aperture	2-19
2-19.	Index Line	2-20
2-20.	BZO Target.....	2-22
2-21.	Windage Knob	2-23
2-22.	Selector Lever - SAFE	2-27
2-23.	Magazine Removal	2-28
2-24.	Locking Bolt Open.....	2-28

LIST OF ILLUSTRATIONS (Continued)

<u>Figure</u>	<u>Title</u>	<u>Page</u>
2-25.	Checking Chamber for Ammunition	2-29
2-26.	Upper Bolt Catch.....	2-29
2-27.	Normal Range Aperture	2-30
2-28.	Elevation Knob.....	2-31
2-29.	Front Sight Post.....	2-31
2-30.	Short Range Aperture.....	2-32
2-31.	Seating Magazine	2-34
2-32.	Pull Charging Handle Back.....	2-35
2-33.	Forward Assist.....	2-35
2-34.	Magazine Release.....	2-36
2-35.	Lock Bolt.....	2-37
2-36.	Tapping Cartridge Case from Chamber	2-37
2-37.	Depressing Trigger Guard Plunger and Open Trigger Guard	2-39
2-38.	Removing Muzzle Cap.....	2-43
2-39.	Pull Charging Handle	2-44
2-40.	Clearing Drain Hole	2-44
3-1.	Removing Handguards Using the “Buddy System”	3-3
3-2.	Takedown Pin.....	3-4
3-3.	Receiver Pivot Pin.....	3-5
3-4.	Upper and Lower Receiver.....	3-5
3-5.	Clamping Bar and Carrying Handle Assembly	3-6
3-6.	Charging Handle and Bolt Carrier Removal	3-7
3-7.	Bolt Carrier and Bolt	3-7
3-8.	Charging Handle Removal	3-8
3-9.	Firing Pin Retaining Pin Removal.....	3-8
3-10.	Bolt Assembly to Locked Position	3-9
3-11.	Removing Firing Pin from Bolt Carrier	3-9
3-12.	Bolt Cam Pin Removal.....	3-10
3-13.	Bolt Assembly Removal.....	3-10
3-14.	Checking Spring Function.....	3-11
3-15.	Extractor Removal.....	3-12
3-16.	Buffer Assembly	3-13
3-17.	Buffer and Action Spring	3-13

LIST OF ILLUSTRATIONS (Continued)

<u>Figure</u>	<u>Title</u>	<u>Page</u>
3-18.	M4 / M4A1 CQBW Buttstock Assembly	3-14
3-19.	Reinstalling Buttstock Assembly	3-15
3-20.	Extractor and Rubber Insert	3-16
3-21.	Ring Gaps	3-17
3-22.	Bolt into Carrier	3-17
3-23.	Seat Firing Pin	3-18
3-24.	Bolt in Forward Position	3-19
3-25.	Install Firing Pin Retaining Pin.....	3-19
3-26.	Charging Handle	3-20
3-27.	Bolt Carrier Group	3-20
3-28.	Charging Handle and Bolt Carrier Group	3-21
3-29.	Join Upper and Lower Receivers	3-21
3-30.	Engage Receiver Pivot Pin.....	3-22
3-31.	Apply Handguards Using the "Buddy System"	3-23
3-32.	Release Magazine Base Catch	3-25
3-33.	Magazine Base Removal.....	3-26
3-34.	Magazine Spring and Follower	3-26
3-35.	Insert Spring and Follower into Magazine.....	3-27
3-36.	Replacing Magazine Base.....	3-28
3-37.	Handguards	3-29
3-38.	Upper Handguard Sections	3-30
3-39.	Lower RAS Assembly	3-31
3-40.	Standard Side Sling Adapter	3-34
3-41.	5.56mm Compensator	3-34
3-42.	M15A2 Blank Firing Attachment (BFA).....	3-35
3-43.	Compensator with M15A2 BFA	3-35
3-44.	M15A2 BFA Attached to Compensator.....	3-36
3-45.	QD Suppressor Locking Latch.....	3-37
3-46.	QD Suppressor Mounted to Compensator	3-38
3-47.	QD Suppressor Latch Plate	3-39
3-48.	EO Tech Sight – Left View	3-43
3-49.	EO Tech Sight– Right View	3-44
3-50.	Mounting Visible Light Illuminator.....	3-45
3-51.	Standard Cleaning Kit.....	3-47
3-52.	Bolt Carrier Group	3-48

LIST OF ILLUSTRATIONS (Continued)

<u>Figure</u>	<u>Title</u>	<u>Page</u>
3-53.	Swabbing Weapon.....	3-50
3-54.	Locking Lugs and Gas Tube	3-52
3-55.	Cleaning Chamber and Locking Lugs.....	3-53
3-56.	Carrier Key.....	3-54
3-57.	Cleaning the Firing Pin Hole.....	3-55
3-58.	Locking Lugs and Extractor Lip.....	3-55
3-59.	Bolt Rings.....	3-56
3-60.	Ejector Cleaning.....	3-56
3-61.	Lubricate Ejector	3-57
3-62.	Lubricate Carrier Key.....	3-58
3-63.	Lubricant Guide.....	3-61
3-64.	Lubricate Front Sight	3-62
3-65.	Lubricate Carrying Handle.....	3-63
3-66.	Apply CLP to Carrier Key.....	3-64
3-67.	Lubricate Bolt Carrier Group	3-65
3-68.	Lubricate Slide and Bolt Carrier.....	3-65
3-69.	Lubricate Lower Receiver Extension Parts	3-66
3-70.	Lubricate Adjustable Rear Sight	3-66
B-1.	Standard Cleaning Kit	B-5
B-2.	Magazine and Sling.....	B-5
B-3.	Otis Cleaning Kit.....	B-6
B-4.	Handguard Sections.....	B-7
C-1.	Tracer Ammunition	C-1
C-2.	Ammunition Examples.....	C-2

LIST OF TABLES

<u>Table</u>	<u>Title</u>	<u>Page</u>
1-1.	M16A2 Characteristics	1-4
1-2.	M16A4 Characteristics	1-5
1-3.	M4 Characteristics	1-6
1-4.	M4A1 CQBW Characteristics	1-7
2-1.	Additional Front Sight Elevation Changes	2-23
2-2.	Rear Sight Elevation Changes Per Click.....	2-23
2-3.	M16A4 Recommended IAL RAS Mounting Positions.....	2-26
2-4.	M4 / M4A1 CQBW Recommended IAL RAS Mounting Positions.....	2-26
3-1.	Preventive Maintenance Checks and Services (PMCS).....	3-70
4-1.	Troubleshooting.....	4-2
B-1.	List of Components.....	B-8
B-2.	Inventory Sheet.....	B-15

SAFETY SUMMARY

WARNING

If the weapon is dropped or jarred with a loaded magazine in place it could chamber a round. (Page 2-13)

WARNING

Always assume every weapon is loaded until it is verified through visual and physical inspection that it is not. Refer to paragraph 2-9 for clearing procedures. (Page 2-15)

WARNING

Confirm the weapon is unloaded and on safe before performing the following procedures. (Pages 2-15, 2-27, 3-2, 3-29, 3-36, 3-38, 3-69)

WARNING

The weapon is now loaded. Ensure it is pointed in a safe direction. (Page 2-16)

WARNING

If a noticeable difference in sound or recoil of the weapon is experienced, stop firing. Either condition could indicate an incomplete powder burn and / or a bullet stuck in the bore. (Page 2-34)

SAFETY SUMMARY (Continued)

WARNING

Do not load with a hot chamber. (Page 2-35)

WARNING

If the weapon stops firing with a live round in the chamber of a hot barrel, remove the round immediately. If the round cannot be removed within 10 seconds, remove magazine and wait 15 minutes with the rifle pointing in a safe direction. This prevents the round from cooking off and avoids possible injury. Keep the face away from the ejection port while clearing a hot chamber. (Page 2-36)

WARNING

Immediately cease fire if an audible popping sound or reduced recoil is experienced during firing. (Page 2-38)

WARNING

Do not apply immediate action. (Page 2-38)

WARNING

If the bullet is stuck in the barrel of the weapon, do not attempt to remove it. Turn the weapon into the armorer. (Page 2-38)

SAFETY SUMMARY (Continued)

WARNING

Do not fire the weapon if water is present in barrel. (Page 2-42)

WARNING

Do not switch bolts between weapons. (Page 3-17)

WARNING

Ensure the cam pin is installed in the bolt group. If the cam pin is not installed, the weapon will still fire and explode. (Page 3-18)

WARNING

Use only blank round M200 ammunition with the BFA. (Page 3-35)

WARNING

The QD suppressor must only be used with the M4A1 CQBW. (Page 3-36)

WARNING

The QD suppressor must only be used with the quick detach compensator. (Page 3-36)

SAFETY SUMMARY (Continued)

WARNING

After use, the QD suppressor will be extremely hot. To remove the QD suppressor while hot, use a bayonet or other available tools to rotate the retainer ring and disengage the QD latch plate. Wear heat resistant gloves when handling hot suppressors. (Pages 3-37, 3-40)

WARNING

Wear eye protection when operating the weapon with the suppressor attached, especially if the operator fires left handed or if water is placed in the suppressor to help reduce first round muzzle flash. (Page 3-39)

WARNING

Limit firing to semi-automatic or burst fire except in emergencies. Do not subject the model QD suppressor to more than 90 rounds of continuous automatic fire. If the limit is reached, allow the unit to cool before resuming fire, if the tactical situation permits. Up to 15 rounds per minute of continual fire is acceptable. Full automatic firing will cause excessive fumes. (Page 3-39)

WARNING

Do not interchange bolts between weapons. (Page 3-59)

SAFETY SUMMARY (Continued)

WARNING

*Do not keep live ammunition near the work area.
(Page 3-69)*

WARNING

Keep clear of muzzle. (Page 4-4)

WARNING

Do not fire seriously corroded ammunition, dented cartridges, cartridges with loose bullets, cartridges exposed to extreme heat (135°) until cooled, cartridges with bullet pushed in (short rounds). (Page C-2)

WARNING

Turn in any damaged or overheated cartridges to range NCO. (Page C-3)

WARNING

Use only authorized ammunition manufactured to U.S. or NATO specifications. (Page C-3)

CAUTION

Never ride the charging handle. Allow it to move forward on its own. (Page 2-15)

SAFETY SUMMARY (Continued)



To prevent accidentally firing the weapon, use care when inserting gloved fingers into trigger guard area. (Page 2-38)



Do not use a screwdriver or any other tool when removing the handguards. Damage to the handguard and / or slip ring may result. (Page 3-2)



Disengage the pivot and takedown pins using hand pressure only. Force other than hand pressure may cause damage to the weapon and replacement of the weapon would be required. Push the pivot and takedown pins only far enough to disengage the upper receiver and lower receiver. (Page 3-4)



If the round nuts and the clamping bar are inadvertently removed, the clamping bar must be reinstalled on the threaded studs in a manner not to protrude past the front of the carrying handle. The round nuts should be reinstalled on the threaded studs by an armorer only. (Pages 3-6, 3-24)

SAFETY SUMMARY (Continued)



Do not damage tip of tiring pin when pushing out extractor pin. Refer to Figure 3-14. (Page 3-11)



Selector lever must be on SAFE or SEMI before closing upper receiver. (Page 3-22)



Do not apply lubricant to the plastic surfaces of the handguard sections. (Page 3-31)



Do not remove the thermal liner from the lower RAS assembly. (Page 3-31)



Do not remove the compensator for any reason. Armorers are not authorized to remove it for cleaning purposes. (Page 3-34)



Do not use tools to tighten the BFA attachment; hand tighten only. (Page 3-36)

SAFETY SUMMARY (Continued)



Do not use wire brushes. (Page 3-41)



Do not allow CLP to flow down into the suppressor body and contaminate the internal baffle areas. CLP and other oily residues in the suppressor body will cause excessive smoke when the weapon is fired. (Page 3-41)



Do not mix lubricants on the same weapon. The weapon must be thoroughly cleaned during change from one lubricant to another. Dry cleaning solvent (SD) is recommended for cleaning during change from one lubricant to another. (Page 3-46)



Do not bend or flex cleaning rod. Ensure the swab goes completely through the compensator. Do not reverse direction while swab is in bore or compensator. (Page 3-49)



Do not interchange parts from one weapon with another weapon. (Page 3-49)

SAFETY SUMMARY (Continued)



Do not remove inner heat shield. (Pages 3-54, 3-59)



Do not dry clean the weapon. Do not use hot water or other solvents to clean the weapon. This will remove the Teflon lubricant built up as a result of using CLP. If CLP is not used, RBC may be used to remove carbon within the bore. (Page 3-60)



Apply only a light coat of CLP to firing pin and firing pin recess in bolt. (Page 3-64)



Do not use Q-tips to clean carrier key. (Page 3-64)



After round is removed, bolt is under tension. (Page 4-4)

**CHAPTER 1
GENERAL INFORMATION AND SAFETY
PRECAUTIONS**

Section I. INTRODUCTION

1-1. SCOPE.

- a. Type of Manual. This manual is provided for use in the operation and operator maintenance of the M16A2, M16A4 Rifle, M4 and M4A1 Close Quarter Battle Weapon (CQBW Carbine).
- b. Equipment Name and Model Number. The M16A4 is a modified M16A2. The M16A4, M4 and M4A1 CQBW weapons are configured with a flat-top upper receiver and barrel assembly, a detachable carrying handle and an integral rear aperture sight. The M16A4 is equipped with the M5 Rail Adapter System (RAS) which replaces the M16A2 handguards. The M4A1 CQBW is equipped with the M4 Rail Adapter System which replaces the M4A1 CQBW Carbine's handguards. Both Rail Adapter Systems provide four additional mounting rails for the attachment of accessories to mission tailor the weapons. The M16A4 and M4A1 CQBW will also accommodate an M203 Quick Detach Mounting Bracket.
- c. Procedures. When a procedure is common to both the M16 Rifle and M4 Carbine, only the M16 configuration will be depicted in this manual. If a procedure is not common to both weapons, the weapon for which the procedure is describing will be identified. If the weapon is configured as either a M16A4 or M4A1 CQBW, refer to the appropriate manuals for operation and maintenance procedures of their components.

1-2. MAINTENANCE FORMS AND PROCEDURES.

The Marine Corps forms and procedures used for equipment maintenance will be those prescribed by the current edition of TM 4700-15/1 (Ground Equipment Record Procedures).

1-3. CORROSION PREVENTION AND CONTROL (CPC).

Corrosion prevention and control of material is a continuing concern. While corrosion is typically associated with rusting metal, it can also include deterioration of other items such as contacts, injection molded plastic and foam inserts in the case. Unusual cracking, softening, swelling or breaking of these or other materials may be signs of corrosion problems.

Report corrosion problems on Standard Form 368, Product Quality Deficiency Report (PQDR). Use keywords such as corrosion, rust, deterioration or cracking to ensure the information identifies a CPC problem.

1-4. DESTRUCTION OF MATERIAL TO PREVENT ENEMY USE.

To render the equipment useless to the enemy, Marine Corps personnel shall destroy it by weapons fire, smashing, disassembly, burning or other means.

Section II. EQUIPMENT DESCRIPTION

1-5. GENERAL DESCRIPTION.

- a. The weapons are lightweight, gas-operated, air-cooled, magazine-fed, shoulder-fired weapons which can be fired in full automatic, three-round bursts or semi-automatic single shots.
- b. The weapons have positive locking of the bolt. The firing pin is part of the bolt and carrier assembly and cannot strike the primer until the bolt is fully locked.
- c. Other features of the weapons include:
 - (1) M4 and M4A1 CQBW Carbine Buttstocks. The M4 and M4A1 CQBW carbine buttstocks have four positions: closed, 1/2 open, 3/4 open and full open.
 - (2) M4A1 CQBW. The M4A1 CQBW carbine is fully automatic.
 - (3) Upper Receiver and Barrel Assembly. The upper receiver and barrel assembly have a fully adjustable rear sight and a compensator that helps keep the muzzle down during firing.
 - (4) Upper and Lower Receivers. The upper and lower receivers open easily for cleaning and inspection.
 - (5) Bolt Group and Barrel Extension. The bolt group and barrel extension are designed with locking lugs that lock the bolt group to the barrel extension.
 - (6) Aluminum Receiver. The aluminum receiver reduces the weight of the rifle.

- (7) Bore and Chamber. The bore and chamber are chrome-plated.

1-6. EQUIPMENT CHARACTERISTICS, CAPABILITIES AND FEATURES.

Table 1-1 lists characteristics, capabilities and features of the M16A2.

Table 1-1. M16A2 Characteristics

M16A2	
Caliber	5.56mm
Weight	with 30 round magazine - 8.79 pounds (approximately)
Length	with compensator - 39-5/8 inches
Mechanical Features	Rifling (RH 1/7 twist)
Firing Characteristics	Muzzle Velocity - 3100 fps Chamber Pressure - 52,000 psi Cyclic Rate of Fire - 800 rounds per minute (approximately)
Max Effective Rates of Fire	Semi - 45 rounds per minute Burst - 90 rounds per minute
Sustained Rate of Fire	12 / 15 rounds per minute
Max Effective Range	601.48 yards (550 meters) (individual/point targets) 874.88 yards (800 meters) (area targets)
Max Range	3936.96 yards (3600 meters)
Fire Selector	SAFE SEMI 3 ROUND BURST

Table 1-2 lists characteristics, capabilities and features of the M61A4.

Table 1-2. M16A4 Characteristics

M16A4	
Caliber	5.56mm
Weight	with 30 round magazine - 8.79 pounds (approximately)
Length	39-5/8 inches
Mechanical Features	Rifling (RH 1/7 twist) Detachable Carrying Handle. Integral Accessory Mounting Rail Adapter System
Firing Characteristics	Muzzle Velocity - 3100 fps Chamber Pressure - 52,000 psi Cyclic Rate of Fire - 800 rounds per minute (approximately)
Max Effective Rates of Fire	Semi - 45 rounds per minute Burst - 90 rounds per minute
Sustained Rate of Fire	12 / 15 rounds per minute
Max Effective Range	601.48 yards (550 meters) (individual / point targets) 656.16 yards (600 meters) (area targets)
Max Range	3936.96 yards (3600 meters)
Fire Selector	SAFE SEMI 3 ROUND BURST

Table 1-3 lists characteristics, capabilities and features of the M4 Carbine.

Table 1-3. M4 Characteristics

M4 Carbine	
Caliber	5.56mm
Weight	with 30 rounds in magazine - 7.5 pounds
Length	Buttstock closed - 29.75 inches Buttstock opened - 33 inches
Mechanical Features	Rifling (RH 1/7 twist) Detachable Carrying Handle. Integral Accessory Mounting Rail
Firing Characteristics	Muzzle Velocity - 2,970 fps (approximately) Chamber Pressure - 52,000 psi Cyclic Rate of Fire - 700-900 rounds per minute (approximately)
Max Effective Rate of Fire	Semi - 45 rounds per minute Burst - 90 rounds per minute
Sustained Rate of Fire	12 / 15 rounds per minute
Max Effective Range	546.8 yards (500 meters) (individual / point targets) 656.16 yards (600 meters) (area targets)
Max Range	3936.96 yards (3600 meters)
Fire Selector	SAFE SEMI 3 ROUND BURST

Table 1-4 lists characteristics, capabilities and features of the M4A1 CQBW.

Table 1-4. M4A1 CQBW Characteristics

M4A1 Carbine Close Quarter Battle Weapon (CQBW)	
Caliber	5.56mm
Weight	with 30 rounds in magazine - 7.5 pounds
Length	Buttstock closed - 29.75 inches Buttstock opened - 33 inches
Mechanical Features	Rifling (RH 1/7 twist) Detachable Carrying Handle. Integral Accessory Mounting Rail
Firing Characteristics	Muzzle Velocity - 2,970 fps (approximately) Chamber Pressure - 52,000 psi Cyclic Rate of Fire - 700-900 rounds per minute (approximately)
Max Effective Rate of Fire	Semi - 45 rounds per minute Burst - 90 rounds per minute
Sustained Rate of Fire	12 / 15 rounds per minute
Max Effective Range	546.8 yards (500 meters) (individual / point targets) 656.16 yards (600 meters) (area targets)
Max Range	3936.96 yards (3600 meters)
Fire Selector	SAFE SEMI AUTO

1-7. LOCATIONS AND DESCRIPTION OF MAJOR COMPONENTS (FIGURE 1-1).

- a. Listed below are the major components and a brief functional description.
 - (1) Upper Receiver and Barrel Assembly. The upper receiver and barrel assembly provides support for the bolt carrier assembly. The barrel chambers the cartridge for firing and directs the projectile.
 - (2) Lower Receiver and Buttstock Assembly (M16A2 and M16A4 only). The lower receiver and buttstock assembly provides firing control for the weapon and storage for basic cleaning materials.
 - (3) Bolt and Carrier Assembly. The bolt and carrier assembly provides stripping, chambering, locking, firing, extraction and ejection of cartridges using the drive springs and projectile propelling gases for power.
 - (4) Charging Handle Assembly. The charging handle assembly provides initial charging of the weapon. The charging handle locks the handle in the forward position during sustained fire to prevent injury to the operator.
 - (5) Cartridge Magazine. The cartridge magazine holds cartridges ready for feeding, provide a guide for positioning cartridges for stripping and provides quick reload capabilities for sustained firing.
 - (6) Small Arms Sling. The small arms sling provides the means for carrying the weapon.
- b. For additional information, refer to Chapter 2 of this manual.



Figure 1-1. Major Components – M16A2



Figure 1-2. M16A4 with Removable Carrying Handle



Figure 1-3. M4 / M4A1 with Collapsing Buttstock and with Removable Carrying Handle

1-8. RAIL ADAPTER SYSTEM (RAS) AND ACCESSORIES.

- a. General. The installation of the Rail Adapter System (RAS) has no effect on the attachment or operation of any current standard accessory. The RAS will not affect the use of the Multiple Integrated Laser Engagement System (MILES), the M7 and M9 bayonets, the M15A2 and M23 blank firing adapters, the top carry sling adapter and standard sling. All are mounted in the standard positions and operated in the standard way. With the lower rail quadrant removed (use the same manner as the standard lower handguard), the 40mm M203 Grenade Launcher will mount under the barrel in the standard location. The M203 Grenade Launcher can be secured by the M203 Quick Attach / Detach (QD) Grenade Launcher Mount or the original factory mount.
- b. Rifle or Carbine. The rifle and carbine rail adapter system consists of the MIL-STD-M1913 rail adapter and handguards. Refer to Figure 1-4 and Figure 1-5.

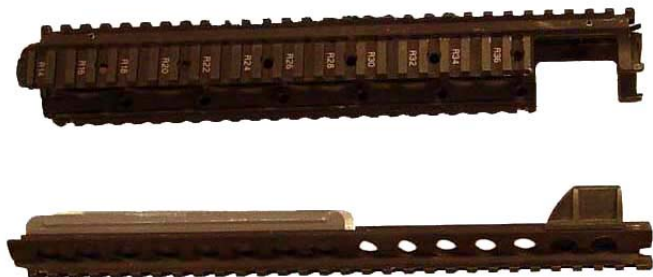

Figure 1-4. Rail Adapters - M16A2 / M16A4 Rifle

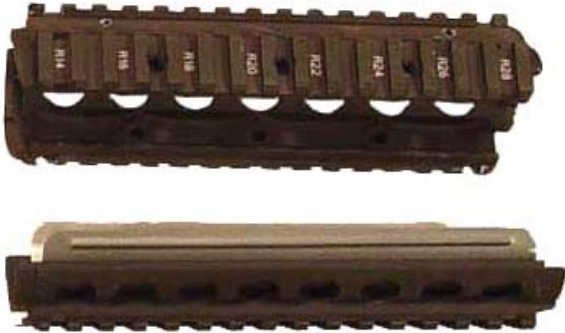

Figure 1-5. Rail Adapters - M4 / M4A1 CQBW Carbine

c. RAS Handguard Sections.

- (1) Handguard sections are quickly attached and detached from the RAS. A spring latch at one end of each handguard section automatically engages cutouts positioned at either end of the four rail sections. Refer to Figure 1-6.

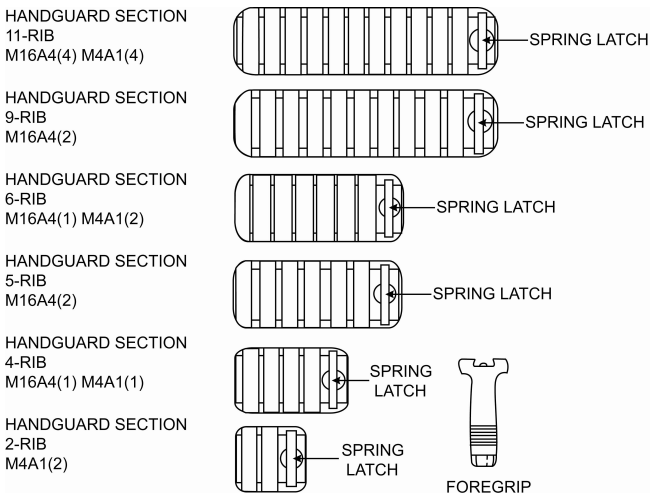

Figure 1-6. Handguards

- (2) To cover the side and bottom quadrants, install the handguard sections from the muzzle end of the RAS. Refer to Figure 1-7.



Figure 1-7. Installation of Handguard Sections to RAS

- (3) To cover the top rail quadrant, install the handguard sections from the rear of the upper receiver group.
- (4) As the spring latch meets the cutouts at either end of the rails, the latch will engage to secure the cutouts. Several different lengths of handguard sections are provided with the Basic Issue Systems. Refer to the handguards by the number of ribs along the outer surfaces, i.e., 11-rib, 9-rib, 6-rib, 5-rib, 4-rib and 2-rib.

NOTE

THE HANDGUARD SECTIONS PERFORM TWO PRIMARY FUNCTIONS. TO PROTECT HANDS FROM DIRECT SKIN CONTACT WITH METAL PARTS OF THE RAS, WHICH MAY BECOME HOT DURING EXTENDED FIRING AND TO PROTECT THE RAIL SURFACES FROM EXCESS WEAR AND DAMAGE. THE HANDGUARDS SHOULD COVER THE UNUSED SECTIONS OF EACH RAIL OF THE RAS AT ALL TIMES.

1-9. M4A1 CQBW CARBINE QUICK ATTACH / DETACH SOUND SUPPRESSOR.

- (1) The QD suppressor provides a quick means to muffle the weapon's muzzle blast, flash and noise for enhanced operational security. The model QD sound suppressor kit includes the QD suppressor and a replacement compensator for M4A1 CQBW carbines. Refer to Figure 1-8.

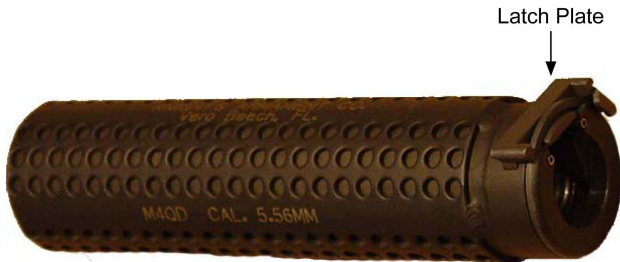

Figure 1-8. QD Sound Suppressor

- (2) The QD muzzle compensator is identical to the issue compensator, except for the addition of a precision locking groove for securing the QD suppressor. The provision of external carbon cutting grooves and an alignment notch in the front at the six o'clock position prevents improper installation of the suppressor. Refer to Figure 1-9.

Standard M16A2/M16A4/M4
Compensator

M4A1 Compensator



Figure 1-9. Compensators

CHAPTER 2 OPERATING INSTRUCTIONS

Section I. CONTROLS AND INDICATORS

2-1. OPERATOR CONTROLS AND INDICATORS.

- a. Right View. Refer to Figure 2-1.
 - (1) Elevation Knob. The elevation knob allows the operator to adjust sights for range changes.
 - (2) Windage Knob. The windage knob allows the operator to adjust / correct for effects of wind.
 - (3) Rear Sight Assembly. The rear sight assembly contains short range (0-200m) and long range (300+m) apertures and adjustment controls.
 - (4) Brass Deflector. The brass deflector prevents ejected cartridge cases from striking the operator.
 - (5) Front Sight Post. The front sight post allows the operator to adjust the strike of the bullet up and down.
 - (6) Bayonet Lug. The bayonet lug allows attachment of a bayonet to the weapon.
 - (7) Ejection Port Cover. The ejection port cover closes over ejection port to prevent sand or dust from entering the chamber. Cover should remain closed when not firing the weapon.
 - (8) Magazine. The magazine contains up to 30 rounds of 5.56mm ammunition.
 - (9) Magazine Release Button. The magazine release button allows the operator to release the magazine and remove it from weapon.

TM 05538/10012-10A/1

- (10) Trigger. The trigger, when pulled, fires the weapon.
- (11) Forward Assist Assembly. Tap the forward assist assembly to ensure the bolt is fully closed and locked.
- (12) Charging Handle. The charging handle allows the operator to chamber a round and cock the weapon.

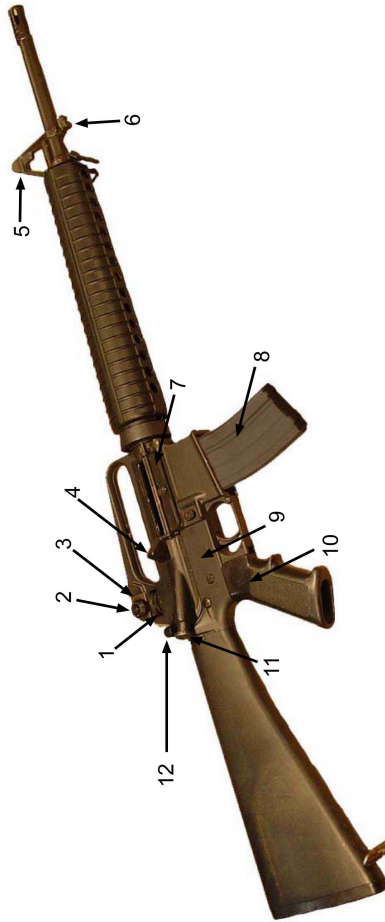

Figure 2-1. M16A2 - Right View

b. Left View. Refer to Figure 2-2.

- (1) Compensator. The compensator prevents the muzzle of the weapon from rising during firing.
- (2) Carrying Handle. The carrying handle allows the operator to carry the weapon.
- (3) Bolt Catch. The bolt catch holds the bolt assembly to the rear when the last round is fired.

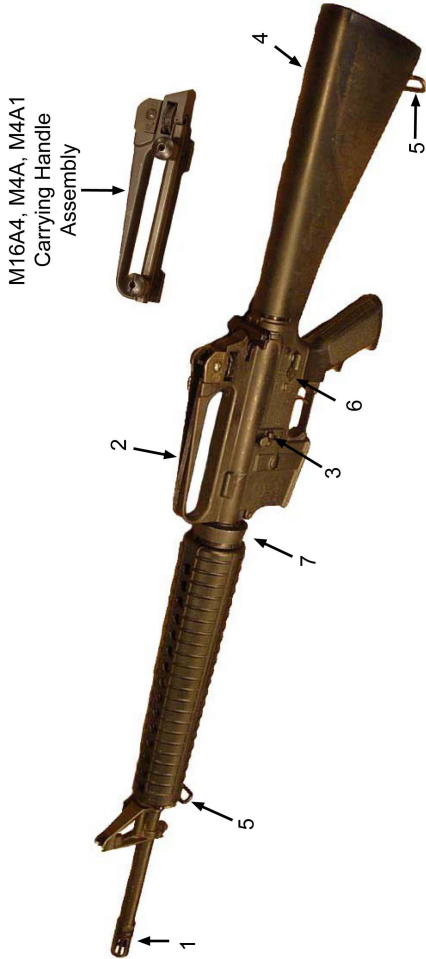

Figure 2-2. M16A2 - Left View

- (4) Buttstock Assembly. The buttstock assembly houses the action spring, buffer assembly and extension assembly. The M4 and M4A1 CQBW have a collapsible buttstock. Refer to Figure 2-3.

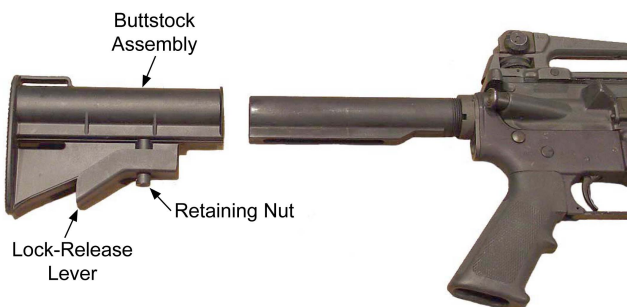

Figure 2-3. M4 / M4A1 CQBW Collapsible Buttstock Assembly

NOTE

THE BUTTSTOCK MAY BE USED FOR STORAGE OF CLEANING GEAR. REFER TO FIGURE 2-4.



Figure 2-4. Cleaning Kit Storage Area

- (5) Sling Swivel. The sling swivel allows the attachment of the sling to the weapon.

- (6) Selector Lever. The selector lever allows the operator to select the mode of fire and place weapon on SAFE.
- (7) Slip Ring. The slip ring holds the handguard in place on the weapon.

2-2. ADJUSTABLE FRONT SIGHT POST.

The front sight post is moved up or down when zeroing the rear sight. Once the rear sight is zeroed, the front sight post should not be moved. Refer to Figure 2-5.

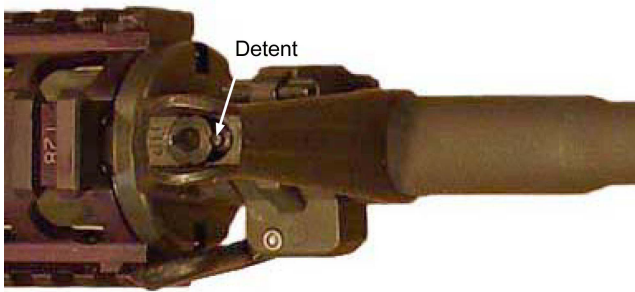

Figure 2-5. Adjustable Front Sight Post

2-3. ADJUSTABLE REAR SIGHT.

Short Range Aperture (0-200 yards) - The larger aperture is used for 0-200 yards during low light and low visibility conditions. The sight is set for 0-200 yards and the windage knob is set for 300 yards. Refer to Figure 2-6.

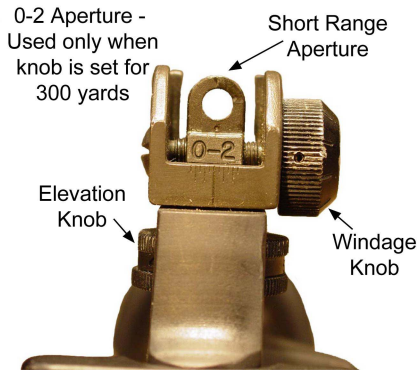

Figure 2-6. Adjustable Rear Sight

2-4. SELECTOR LEVER.

- a. SAFE. Weapon will not fire. Selector lever cannot be on SAFE unless weapon is cocked. Always place the selector lever on SAFE when loading and unloading. Refer to Figure 2-7.



Figure 2-7. Selector lever - SAFE

- b. SEMI. Weapon will fire one round each time the trigger is pulled. Refer to Figure 2-8.



Figure 2-8. Selector lever - SEMI

- c. BURST. Weapon will fire a three-round burst each time the trigger is pulled. Refer to Figure 2-9.



Figure 2-9. Selector lever - BURST

- d. AUTO (CQBW only). Carbine will continue to fire as long as the trigger is pulled. Refer to Figure 2-10.



Figure 2-10. M4A1 CQBW Only - Selector lever - AUTO

Section II. OPERATING PROCEDURES

2-5. LOADING MAGAZINE.

NOTE

THE MAGAZINE MAY BE LOADED QUICKLY USING THE MAGAZINE FILLER FOUND IN EACH BANDOLEER OR A TEN-ROUND STRIPPER CLIP. REFER TO FIGURE 2-11.

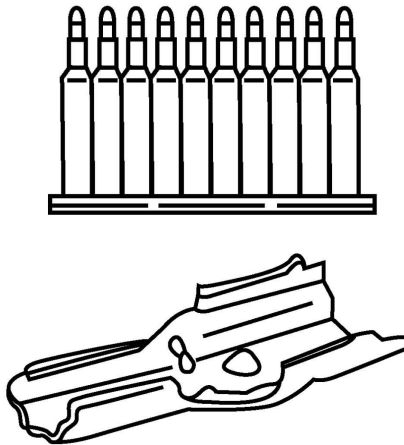

Figure 2-11. Stripper Clip and Magazine Filler

a. Using Magazine Filler.

- (1) With the magazine filler in place, place a ten-round stripper clip in position. Using thumb pressure on the rear of the top cartridge, press down firmly until all ten rounds are below the feed lips of the magazine. Refer to Figure 2-12.

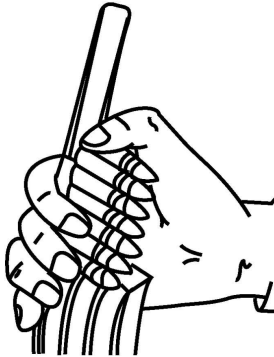

Figure 2-12. Loading Magazine with Stripper Clip

- (2) Remove the empty stripper clip while holding the magazine filler in place.
- (3) Repeat steps until three rounds of clips are loaded.
- (4) Remove magazine filler and retain it for future use.

WARNING

IF THE WEAPON IS DROPPED OR JARRED WITH A LOADED MAGAZINE IN PLACE IT COULD CHAMBER A ROUND.

- b. Loading for Semi-Auto Fire and Chambering a Round.
 - (1) With hammer cocked, place the selector lever on SAFE. Point muzzle in a safe direction.
 - (2) Open the bolt, lock it to the rear and check the chamber. Ensure the chamber is clear.
 - (3) Push upward until magazine catch engages and holds the magazine.
 - (4) Tap upward on the magazine to ensure it is properly seated. Refer to Figure 2-13.



Figure 2-13. Seating the Magazine

NOTE

MAGAZINE MAY BE LOADED WITH THE BOLT ASSEMBLY OPEN OR CLOSED.

- (5) Depress upper portion of bolt catch. Bolt should go forward. Refer to Figure 2-14.

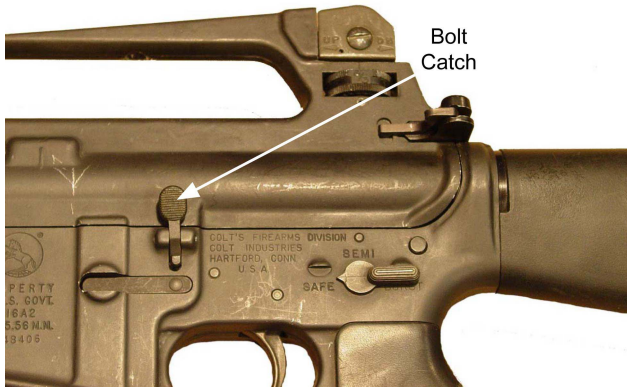

Figure 2-14. Bolt Catch

- (6) Tap the forward assist to ensure bolt is fully forward and locked. Refer to Figure 2-15.



Figure 2-15. Forward Assist



**NEVER RIDE THE CHARGING HANDLE.
ALLOW IT TO MOVE FORWARD ON ITS OWN.**

NOTE

CLOSE EJECTION PORT COVER IF THE WEAPON IS NOT TO BE IMMEDIATELY FIRED.

- c. Loading for a Three-Round Burst and Chambering a Round. To guarantee a three-round burst the first time the trigger is pulled, use the following procedures:

WARNINGS

ALWAYS ASSUME EVERY WEAPON IS LOADED UNTIL IT IS VERIFIED THROUGH VISUAL AND PHYSICAL INSPECTION THAT IT IS NOT. REFER TO PARAGRAPH 2-9 FOR CLEARING PROCEDURES.

CONFIRM THE WEAPON IS UNLOADED AND ON SAFE BEFORE PERFORMING THE FOLLOWING PROCEDURES.

- (1) Place the selector lever on BURST.
- (2) Pull trigger and hold it to the rear.
- (3) Pull charging handle to rear and let it go three times.
- (4) Pull charging handle to rear one more time; hold it to the rear.
- (5) Release the trigger.

- (6) Push in on the bottom portion of bolt catch, locking the bolt to the rear.
- (7) Slide the charging handle forward. Refer to Figure 2-16.



Figure 2-16. Push Charging Handle Forward

- (8) Place the selector lever on SAFE.
- (9) Insert a loaded magazine. Push on the upper portion of the bolt catch to allow the bolt to go forward.

WARNING

THE WEAPON IS NOW LOADED. ENSURE IT IS POINTED IN A SAFE DIRECTION.

- (10) Placing the selector lever on BURST and pulling the trigger will emit a three-round burst.

NOTE

CLOSE THE EJECTION PORT COVER IF THE WEAPON IS NOT TO BE IMMEDIATELY FIRED.

2-6. M16A4 / M16A2 RIFLE AND M4 / M4A1 CQBW CARBINE (36 YARD) ZEROING.

NOTE

BZO IN THIS TM IS FOR M16A4 WITH IRON SIGHTS ONLY. SEE APPROPRIATE TM WHEN USING DIFFERENT SIGHT SYSTEMS.

- a. Short range zeroing allows battle sight zero (BZO) to be confirmed before firing at longer ranges (0-500 yards).
- b. The operator should learn and understand the following three important zeroing terms before zeroing:
 - (1) Sight line is an imaginary straight line starting at the operator's eye, running through the sighting system and down range to the target.
 - (2) Trajectory line is the path of the bullet as it travels to the target. The line of trajectory is a downward curving path, and is always affected by gravity and sometimes wind as well.
 - (3) Bore line is an imaginary straight line running through the center of the weapon's barrel. In the M16A4 and M4A1 CQBW, the bore line also represents the weapon's central axis.
- c. When properly zeroed for longer ranges, the M16A4 sighting systems cause the bore line and the fired bullet to angle upward overcoming the effects of gravity. Most M16A4 sighting systems are oriented

several inches above the bore line. The curved trajectory line (bullet path) cuts through the sight line (or intersects it), in two locations. Refer to Figure 2-17.

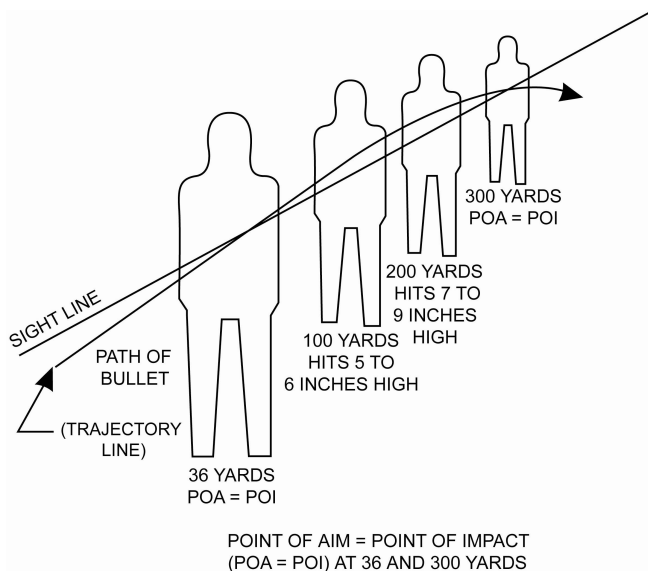

Figure 2-17. Bullet Trajectory

The first intersection of sight line and bullet trajectory is at short range and is a convenient location for short range zeroing. The second intersection is the desired battle sight zero range (point of aim / point of impact at 300 yards). Between the two intersections, the trajectory line is above the sight line as illustrated. If the distances above the sight line are known at specific ranges, i.e., 100 or 200 yards, this data can be used to verify a longer range zero. If possible, verify battle sight zero at the actual ranges required.

**2-7. M16A4 RIFLE AND M4A1 CQBW CARBINE
ZEROING PROCEDURES FOR A 300 YARD
BATTLE SIGHT ZERO.**

- a. Position a point of aim / point of impact bullseye type target 36 yards from the firing line. A field expedient target may be made from an ordinary piece of 8-1/2 inch by 11-inch paper with a 2 1/2-inch to 3-inch black bullseye drawn in the middle.

- b. Flip the rear sight aperture so the normal range (smaller diameter) peep is up and ready to use. Rotate the elevation knob in the DN (down) direction counterclockwise until it stops moving. Refer to Figure 2-18.

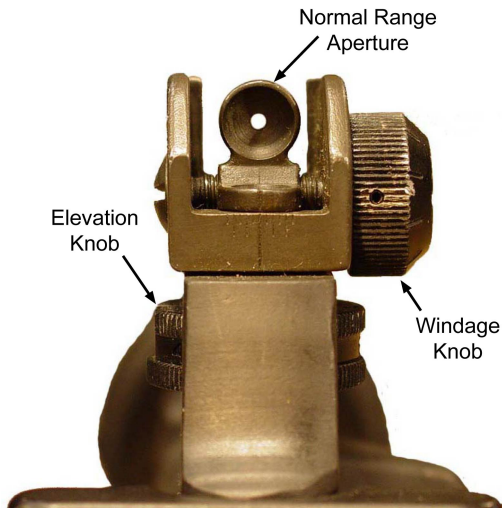

Figure 2-18. Normal Range Aperture

- c. If necessary, rotate the elevation knob in the UP (up) direction clockwise until the 6/300 yard mark on the dial aligns to the index line located beneath the windage screw. Refer to Figure 2-19.

NOTE

M16A2 HAS 8/300 MARK ON THE DIAL.

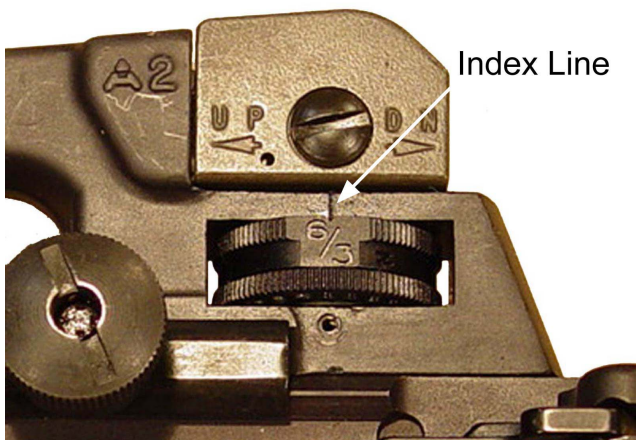

Figure 2-19. Index Line

NOTES

M16A4, M4 AND M4A1 CQBW STRIKE OF THE ROUND MOVES 1/2-INCH FOR EVERY 100 YARDS (REAR SIGHT ELEVATION ONLY).

M16A2 STRIKE OF THE ROUND MOVES 1-INCH FOR EVERY 100 YARDS (REAR SIGHT ELEVATION ONLY).

WINDAGE ADJUSTMENT FOR M16A4 AND M4A1 CQBW IS 1/2-INCH FOR EVERY 100 YARDS.

- d. While aiming at the 36 yard target bullseye's center mast, carefully fire a three-round group. If the shot group is not in the bullseye's dead center, adjust the weapon's sights in the following manner:

NOTES

M4 / M4A1 CQBW CARBINE ONLY. THE ELEVATION KNOB SHOULD BE AT 6/3 MINUS 1. ZERO ON A 36 YARD BZO, POINT OF AIM / POINT OF IMPACT. MOVE THE DIAL TO 6/3 PLUS 1 OR 6/3 PLUS 2. A 300 YARD BZO HAS BEEN ESTABLISHED.

FOR FRONT SIGHT - ONE CLICK EQUALS APPROXIMATELY 3/8-INCH AT 36 YARDS FOR A RIFLE AND 1/2-INCH AT 36 YARDS FOR A CARBINE.

- (1) Elevation (Front Sight).
 - (a) Identify center of shot group on BZO target. Refer to Figure 2-20.
 - (b) To move shot group up, rotate the front sight post clockwise the required number of clicks as identified on the 36 yard BZO target.
 - (c) To move the shot group down, rotate the front sight post counterclockwise the required number of clicks as identified on the 36 yard BZO target.

36 - YARD

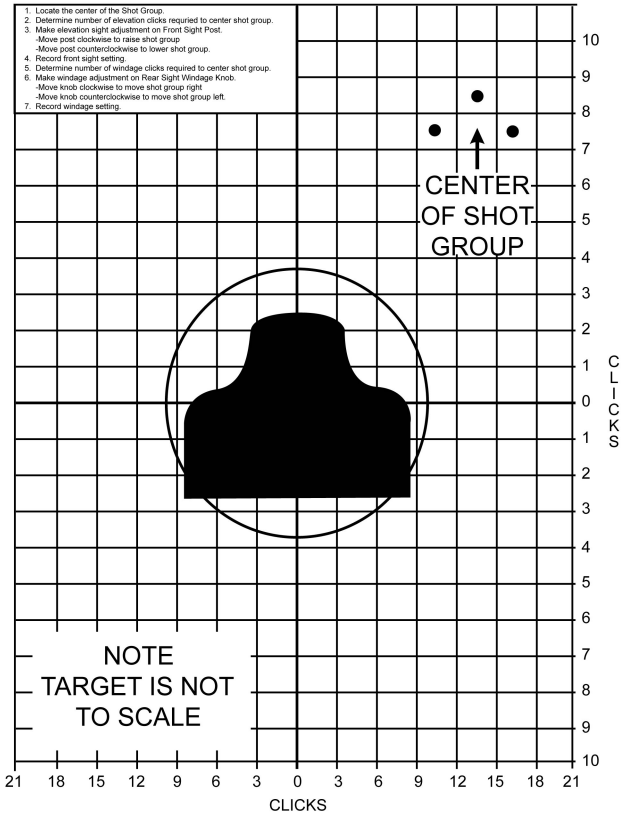

Figure 2-20. BZO Target

Table 2-1. Additional Front Sight Elevation Changes

Known Distance	Rifle	Carbine
100 Yards	1-3/8 inch	1-7/8 inch
200 Yards	2-3/4 inch	3-3/4 inch
300 Yards	4-1/8 inch	5-3/8 inch

Table 2-2. Rear Sight Elevation Changes Per Click

Known Distance	M16A2	M16A4	M4 / M4A1 CQBW
100 yards	1 inch	1/2 inch	3/4 inch
200 yards	2 inches	1 inch	1-1/2 inches
300 yards	3 inches	1-1/2 inches	2-1/4 inches
400 yards	4 inches	2 inches	3 inches
500 yards	5 inches	2-1/2 inches	3-3/4 inches

(2) Windage.

- (a) To move the shot group right, rotate the windage knob clockwise (in the direction of the arrow pointed to the R marked on the knob). Refer to Figure 2-21.



Figure 2-21. Windage Knob

- (b) To move the shot group left, rotate the windage knob counterclockwise.
- e. While aiming at the bullseye's center mark, fire another three-round group. If the shot group is not in the bullseye's dead center, adjust the weapon's sights as described in paragraph 2-7.d.
- f. When the shot group is centered at the bullseye's dead center, the front and rear sights are BZO'd for a 300 yard zero.

NOTES

A WEAPON ZEROED USING THE FIELD EXPEDIENT BZO METHOD AT 36 YARDS CAN BE TAKEN INTO BATTLE. A BZO ESTABLISHED AT 300 YARDS IS CONSIDERED TO BE MORE ACCURATE THAN A BZO ESTABLISHED AT 36 YARDS. (THIS IS DUE TO MINOR INCONSISTENCIES A MARINE CAN APPLY AT 36 YARDS THAT WILL GREATLY MULTIPLY AT 300 YARDS.)

WHEN BZO IS ESTABLISHED ON A KNOWN DISTANCE RANGE, REFER TO TABLE 2-2 FOR REAR SIGHT ELEVATION ADJUSTMENTS.

- g. Once zeroed in the manner described above, the rear sight's 400, 500 and 600 yard range marks may also be used for precise and area point of aim / point of impact target engagement as the tactical situation permits. To more accurately engage targets at these greater ranges, rotate the elevation knob in the UP direction (clockwise) until the desired major range numbers (#4, #5 or #6) align to the index line located beneath the windage screw.

NOTE

WHEN EXACT RANGES ARE KNOWN, THE INTERMEDIATE CLICKS BETWEEN THE MAJOR RANGE MARKINGS MAY BE USED TO APPROXIMATE RANGES SUCH AS 350 YARDS OR 525 YARDS.

- h. Under most daylight conditions, the weapon should be carried with the 300 yard battle sight zero set. (The 6/300 yard mark aligned to the index line located beneath the windage screw. The M16A2 is the 8/300 mark.)

NOTE

TO ENGAGE TARGETS AT 200 YARDS OR LESS DURING PERIODS OF POOR VISIBILITY AND AT NIGHT, WITH THE REAR SIGHT SET AT THE 300 YARD BATTLE SIGHT ZERO, FLIP THE REAR SIGHT APERTURE FORWARD SO THE LARGER DIAMETER APERTURE IS UP AND READY TO USE. THE LARGE DIAMETER IS MARKED 0-2 AND IS PRE-SET FOR A 200 YARD POINT OF AIM / POINT OF IMPACT.

- i. Verify the BZO field expedient short range zero at actual ranges if possible. If additional front sight elevation changes are required during actual range zero confirmation, refer to Table 2-1.

2-8. SPECIAL INFRARED AIMING LIGHT ZEROING CONSIDERATIONS.

It is recommended the laser boresight system be used to zero night vision sights and IR aiming lights. Refer to TM 10471A-12&P/1, Operator's Manual for the Laser Boresight System (LBS). Refer to Table 2-3 and Table 2-4 for recommended IAL RAS mounting positions.

Table 2-3. M16A4 Recommended IAL RAS Mounting Positions

Weapon / Combination	Operator is:	RAS Slot Number:	IAL Activated by:	Switch Paddle Position
M16A4 Rifle	Right-Handed	T40	Left Thumb	Paddle Down
	Left-Handed	T40	Right Middle Finger	Paddle Down
M16A4 / M203 Grenade Launcher	Right-Handed	L35	Left Thumb	Remote Switch
	Left-Handed	R35	Right Thumb	Remote Switch
M16A4 Rifle w / Top Rail Occupied	Right-Handed	L35	Left Thumb	Remote Switch
	Left-Handed	R35	Right Thumb	Remote Switch

Table 2-4. M4 / M4A1 CQBW Recommended IAL RAS Mounting Positions

Weapon / Combination	Operator is:	RAS Slot Number:	IAL Activated by:	Switch Paddle Position
M4 Carbine / M4A1 CQBW	Right-Handed	T26	Left Thumb	Paddle Down
	Left-Handed	T26	Right Middle Finger	Paddle Down
M4 / M4A1 CQBW / M203 Grenade Launcher	Right-Handed	R26	Left Middle Finger	Remote Switch
	Left-Handed	R26	Right Thumb	Remote Switch
M4 / M4A1 CQBW Carbine w / Top Rail Occupied	Right-Handed	L28	Left Thumb	Remote Switch
	Left-Handed	R37	Right Thumb	Remote Switch

2-9. CLEARING THE WEAPON.

WARNING

CONFIRM THE WEAPON IS UNLOADED AND ON SAFE BEFORE PERFORMING THE FOLLOWING PROCEDURES.

1. Point the weapon in a safe direction. Place selector lever on SAFE. If the weapon is not cocked, the selector lever cannot be pointed toward SAFE. Refer to Figure 2-22.



Figure 2-22. Selector lever - SAFE

2. Press magazine release and remove magazine. Refer to Figure 2-23.



Figure 2-23. Magazine Removal

3. To lock the bolt open, pull charging handle rearward. Press bottom of bolt catch and allow bolt to move forward until it engages the bolt catch. Return charging handle to forward. Verify selector lever is on SAFE. Refer to Figure 2-24.



Figure 2-24. Locking Bolt Open

4. Check receiver and chamber to ensure these areas contain no ammunition. Refer to Figure 2-25.



Figure 2-25. Checking Chamber for Ammunition

5. With the selector lever on SAFE, allow the bolt to go forward by pressing upper portion of bolt catch. The weapon is now on SAFE. Refer to Figure 2-26.



Figure 2-26. Upper Bolt Catch

NOTE

NORMAL RANGE FOR THE M4A1 CQBW IS 300 - 600 YARDS.

Normal Range Aperture (300 - 800 yards) - The normal range aperture is unmarked and is used for most firing situations. It is used in conjunction with the elevation knob for 300, 400, 500, 600, 700 and 800 yard targets. Refer to Figure 2-27.

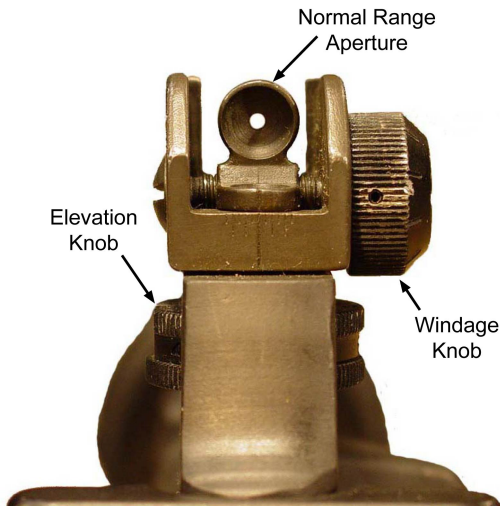

Figure 2-27. Normal Range Aperture

2-10. FIELD FIRING TECHNIQUES.

- a. Establish zero (see para 2-7). The elevation knob is now set starting at 300 yards and continuing in 100 yard increments up to 800 yards.

- b. Rotate the elevation knob until the desired number (4, 5, 6, 7 or 8) is aligned with the mark on the left side of the receiver. Maximum elevation for the M4A1 CQBW and M16A4 is 600 yards. Refer to Figure 2-28.

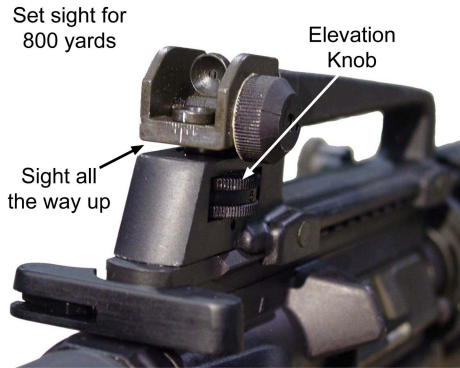

Figure 2-28. Elevation Knob

- c. Obtain a good sight picture and good sight alignment with the unmarked aperture and the front sight post. Refer to Figure 2-29.

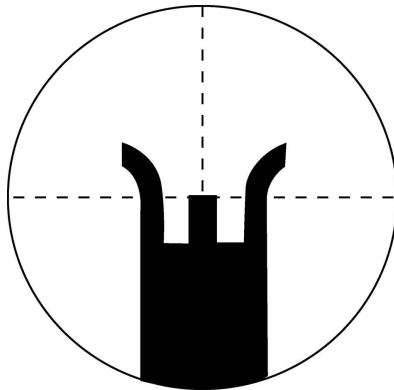

Figure 2-29. Front Sight Post

- d. Squeeze the trigger and fire.

NOTES

USE THE CLICKS BETWEEN THE NUMBERS ON THE ELEVATION KNOB WHEN MORE ELEVATION IS REQUIRED PAST A DESIRED RANGE MARK.

THE SHORT RANGE APERTURE FLIPS FORWARD TO EXPOSE A LARGER APERTURE MARKED 0-2. USE THE 0-2 APERTURE ONLY WHEN THE 3 IS ALIGNED WITH THE MARK ON THE LEFT SIDE OF THE RECEIVER AND THE SIGHT IS ROTATED DOWN. THIS WILL AUTOMATICALLY GIVE A ZERO OF 200 YARDS. USE THE 0-2 APERTURE WHEN FIRING THE WEAPON AT NIGHT OR AT CLOSE RANGE, SUCH AS IN A CITY OR IN DENSE JUNGLE. REFER TO FIGURE 2-30.

0-2 Aperture -
Used only when
knob is set for
300 yards



Figure 2-30. Short Range Aperture

2-11. ADDITIONAL INFORMATION FOR WEAPON SIGHTS.

The weapon sights should be set to a combat zero of 300 yards. To engage a target at longer ranges, i.e., 500 to 800 yards (M16A2 and M4), 500 to 600 yards (M4A1 CQBW), perform the following:

- a. Rotate the elevation knob so the desired range mark is aligned with the mark on the left side of the receiver.
- b. Aim, squeeze the trigger and fire.

NOTE

RETURN THE DIAL TO 300 YARDS WHEN THE MISSION IS OVER.

For firing the weapon at night or at close range, perform the following:

- (1) Rotate the elevation knob counterclockwise to the 300-yard mark.

NOTE

THE 0-2 APERTURE IS PRESET FOR TARGETS BETWEEN 0 AND 200 YARDS. MOVING TARGETS AT CLOSE RANGES ARE EASIER TO HIT IF THE LARGER APERTURE IS USED.

- (2) Flip the unmarked aperture down and use the larger aperture marked 0-2.

WARNING

IF A NOTICEABLE DIFFERENCE IN SOUND OR RECOIL OF THE WEAPON IS EXPERIENCED, STOP FIRING. EITHER CONDITION COULD INDICATE AN INCOMPLETE POWDER BURN AND / OR A BULLET STUCK IN THE BORE.

NOTE

IF THE TRIGGER IS RELEASED BEFORE ALL THREE ROUNDS ARE FIRED, THE NEXT PULL ON THE TRIGGER WILL FIRE ONLY THE REMAINING ROUNDS FROM THE PREVIOUS BURST. ONCE PRESSURE IS APPLIED, MAINTAIN THE PRESSURE UNTIL THE THREE-ROUND CYCLE IS COMPLETE.

2-12. IMMEDIATE ACTION.

If the weapon stops firing, perform the following immediate actions:

- a. Slap upward on magazine to ensure it is properly seated. Refer to Figure 2-31.



Figure 2-31. Seating Magazine

WARNING

DO NOT LOAD WITH A HOT CHAMBER.

- b. Pull charging handle all the way back. Observe ejection of the case or cartridge. Check the chamber for obstruction. Refer to Figure 2-32.

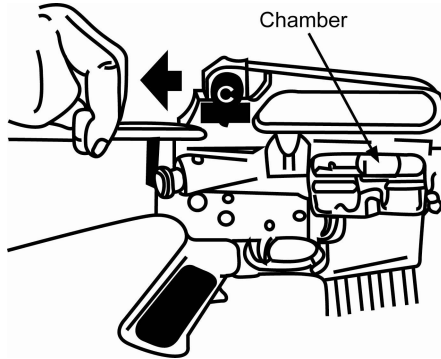

Figure 2-32. Pull Charging Handle Back

- c. If the cartridge or case is ejected or the chamber is clear, release the charging handle to feed new round. Do not ride the charging handle forward.
- d. Tap forward assist. Refer to Figure 2-33.



Figure 2-33. Forward Assist

- e. If the weapon still fails to fire after performing immediate action, check again for a jammed cartridge case. Perform remedial action.

2-13. REMEDIAL ACTION.

WARNING

IF THE WEAPON STOPS FIRING WITH A LIVE ROUND IN THE CHAMBER OF A HOT BARREL, REMOVE THE ROUND IMMEDIATELY. IF THE ROUND CANNOT BE REMOVED WITHIN 10 SECONDS, REMOVE THE MAGAZINE AND WAIT 15 MINUTES WITH THE WEAPON POINTING IN A SAFE DIRECTION. THIS PREVENTS THE ROUND FROM COOKING OFF AND AVOIDS POSSIBLE INJURY. KEEP THE FACE AWAY FROM THE EJECTION PORT WHILE CLEARING A HOT CHAMBER.

- a. If a cartridge case is stuck in the chamber, follow the illustrations and steps below to remove the cartridge:

- (1) Remove the magazine. Refer to Figure 2-34.



Figure 2-34. Magazine Release

- (2) Lock the bolt to the rear. Refer to Figure 2-35.



Figure 2-35. Lock Bolt

- (3) Place the selector lever on SAFE.
- (4) Insert cleaning rod and tap out cartridge case. Refer to Figure 2-36.



Figure 2-36. Tapping Cartridge Case from Chamber

2-14. BULLET STUCK IN BORE.

WARNINGS

IMMEDIATELY CEASE FIRE IF AN AUDIBLE POPPING SOUND OR REDUCED RECOIL IS EXPERIENCED DURING FIRING.

DO NOT APPLY IMMEDIATE ACTION.

IF THE BULLET IS STUCK IN THE BARREL OF THE WEAPON, DO NOT ATTEMPT TO REMOVE IT. TURN THE WEAPON INTO THE ARMORER.

- (1) Retract bolt slowly and remove spent cartridge case.
- (2) Clear weapon and check for unburned powder grains in the receiver or bore and for a bullet stuck in the bore.
- (3) Remove unburned powder or bullet from bore before resuming firing.
- (4) If the bullet is stuck in bore, return the weapon to the armorer.

2-15. OPERATIONS UNDER UNUSUAL CONDITIONS.

- a. Extreme Cold Climate - Arctic.

CAUTION

TO PREVENT ACCIDENTALLY FIRING THE WEAPON, USE CARE WHEN INSERTING GLOVED FINGERS INTO TRIGGER GUARD AREA.

- (1) To operate the weapon in extreme cold when wearing arctic mittens, depress the trigger guard

plunger and open the trigger guard to obtain easy access to the trigger. Refer to Figure 2-37.



Figure 2-37. Depressing Trigger Guard Plunger and Open Trigger Guard

- (2) Cleaning and lubrication should be accomplished inside a warm room and the weapon should be at room temperature if possible.
 - (a) Apply a light coat of Lubricant, Artic Weather (LAW) to all functional parts.
 - (b) To prevent condensation and freezing, allow gradual cooling by keeping the weapon covered when moving from a warm to a cold area.
 - (c) Always attempt to keep the weapon dry.
 - (d) Unload and hand function the weapon every 30 minutes to help prevent freezing of functional parts.
 - (e) Do not lay a warm weapon directly in snow or ice.

- (f) When moving a cold weapon into a warm area, condensation (moisture) will form in and on the weapon. If possible, leave the weapon in a protected, cold area outside. When the weapon is brought into a warm area, as it reaches room temperature, it should be disassembled and wiped dry several times.
 - (g) Ensure the insides of magazines and ammunition are wiped dry. Moisture can freeze and cause malfunctions. Do not lubricate the ammunition.
 - (h) The use of the muzzle cap, a protective magazine bag and an overall weapon cover will help protect the weapon. Use these items whenever the tactical situation permits.
 - (i) For extended operations in extreme cold, have unit armorer remove the trigger guard.
- b. Hot, Wet Climate - Jungle: Use CLP to clean and lubricate the weapon.
- (1) Perform normal maintenance as outlined in Table 3-1 and in paragraph 3-21.a.
 - (2) Clean and lubricate the weapon more frequently. Inspect hidden surfaces of the bolt and carrier assembly, upper receiver and chamber / barrel extension (locking lugs) and the lower receiver and receiver extension assembly (buffer tube) for corrosion. Pay close attention to the spring-loaded detents on the weapon.
 - (3) To help prevent corrosion, remove handprints with a dry wiping rag. Lubricate lightly with CLP.

- (4) Unload and check the inside of magazines frequently for corrosion and moisture. Wipe ammunition dry before reloading.
 - (5) Use magazine bag and muzzle cap for protection when the tactical situation permits.
- c. Hot, Dry Climate - Desert: Use CLP to clean and lubricate the weapon.

NOTE

HOT, DRY CLIMATES ARE USUALLY AREAS CONTAINING BLOWING SAND AND FINE DUST. DESERTS CAN BE HOT DURING DAYLIGHT HOURS AND FREEZING DURING HOURS OF DARKNESS. THIS HARSH ENVIRONMENT WILL SEVERELY TAX THE WEAPON AS WELL AS ALL OTHER TYPES OF EQUIPMENT. THE WEAPON'S CONTINUED OPERATION WILL DEPEND ON STRICTLY AND ROUTINELY FOLLOWING DETAILED CLEANING AND LUBRICATING PROCEDURES.

- (1) Dust and sand will get into the weapon and magazines causing malfunctions. Perform a thorough cleaning of the weapon daily and after all firing missions.

NOTE

ALWAYS SHAKE CLP PRIOR TO USE.

- (2) Corrosion is less likely to form on metal parts in a dry climate; therefore, apply lubrication to the internal working surfaces and functional parts only. Use normal amounts of CLP for lubrication. Unload and dry ammunition and inside of magazines daily. Do not lubricate magazines.

- (3) The use of an overall weapon protection cover, a muzzle cap and spare magazine protective bags will help protect the weapon / ammunition from sand and dust. Use these items when the tactical situation permits.
- (4) At all times, as a minimum effort to help keep out sand and dust, keep the bolt and ejection port cover closed, a magazine installed in the weapon, and a muzzle cap on the muzzle.

NOTE

REMOVAL OF THE CAP PRIOR TO FIRING IS RECOMMENDED. PLACE IT IN A POCKET FOR FUTURE USE. IT IS NOT DANGEROUS TO FIRE THE RIFLE WITH THE MUZZLE CAP INSTALLED.

d. Heavy Rain and Fording Operations - All Climates.

- (1) Perform maintenance in accordance with the climate conditions.
- (2) Always attempt to keep weapon dry.
- (3) Use a weapon cover, a muzzle cap and protective bags to protect weapon, ammunition and magazines.

WARNING

DO NOT FIRE THE WEAPON IF WATER IS PRESENT IN THE BARREL.

- (4) Always drain any water from the barrel prior to firing. Dry the bore with a clean swab.

- e. Nuclear, Biological and Chemical (NBC). General procedures can be found in Marine Corps Warfighting Publication: MCWP 3-37.2A and MCWP 3-37.3.
- f. After Fording.
 - (1) Remove the muzzle cap. Refer to Figure 2-38.



Figure 2-38. Removing Muzzle Cap

- (2) Point the muzzle down and shake vigorously.

- (3) Pull charging handle 2 to 3 inches rearward and allow water to drain. Refer to Figure 2-39.



Figure 2-39. Pull Charging Handle

- (4) Clear the drain hole in the stock with a pipe cleaner and drain the weapon. Refer to Figure 2-40.



Figure 2-40. Clearing Drain Hole

- (5) Release charging handle and strike forward assist to seat round and lock bolt.

**CHAPTER 3
SCHEDULED MAINTENANCE**

Section I. INTRODUCTION

3-1. GENERAL.

Chapter 3 includes operator disassembly and reassembly procedures, lubrication and preventive maintenance checks and services (PMCS). PMCS procedures are in Table 3-1.

Section II. DISASSEMBLY AND REASSEMBLY

3-2. UPPER RECEIVER DISASSEMBLY.

WARNING

CONFIRM THE WEAPON IS UNLOADED AND ON SAFE BEFORE PERFORMING THE FOLLOWING PROCEDURES.

- a. Clear the Weapon. Refer to paragraph 2-9.
- b. Remove the Sling.

CAUTION

DO NOT USE A SCREWDRIVER OR ANY OTHER TOOL WHEN REMOVING THE HANDGUARDS. DAMAGE TO THE HANDGUARD AND / OR SLIP RING MAY RESULT.

- c. Remove Handguards (M16A2).

NOTE

THE ROUND HANDGUARDS ARE IDENTICAL AND CAN BE INTERCHANGED (TOP OR BOTTOM).

- (1) Place the weapon on the buttstock, press down on the slip ring with both hands.

- (2) Have another person pull the handguards free using the “Buddy System”. Refer to Figure 3-1.



Figure 3-1. Removing Handguards Using the “Buddy System”

- d. Separate Upper and Lower Receiver.



DISENGAGE THE PIVOT AND TAKEDOWN PINS USING HAND PRESSURE ONLY. FORCE OTHER THAN HAND PRESSURE MAY CAUSE DAMAGE TO THE WEAPON AND REPLACEMENT OF THE WEAPON WOULD BE REQUIRED. PUSH THE PIVOT AND TAKE-DOWN PINS ONLY ENOUGH TO DISENGAGE THE UPPER RECEIVER AND LOWER RECEIVER.

- (1) Push in the takedown pin as far as it will go. Pivot the upper receiver from lower receiver. Refer to Figure 3-2.



Figure 3-2. Takedown Pin

- (2) Push in the receiver pivot pin. Refer to Figure 3-3.



Figure 3-3. Receiver Pivot Pin

- (3) Separate upper and lower receivers. Refer to Figure 3-4.



Figure 3-4. Upper and Lower Receivers



IF THE ROUND NUTS AND THE CLAMPING BAR ARE INADVERTENTLY REMOVED, THE CLAMPING BAR MUST BE REINSTALLED ON THE THREADED STUDS IN A MANNER NOT TO PROTRUDE PAST THE FRONT OF THE CARRYING HANDLE. THE ROUND NUTS SHOULD BE REINSTALLED ON THE THREADED STUDS BY AN ARMORER ONLY.

e. Remove Carrying Handle Assembly (M16A4, M4, M4A1 CQBW).

- (1) Loosen the round nuts on the left side of the carrying handle, approximately 4 turns.
- (2) Loosen the clamping bar from the left side of the upper receiver and lift off the carrying handle assembly. Refer to Figure 3-5.

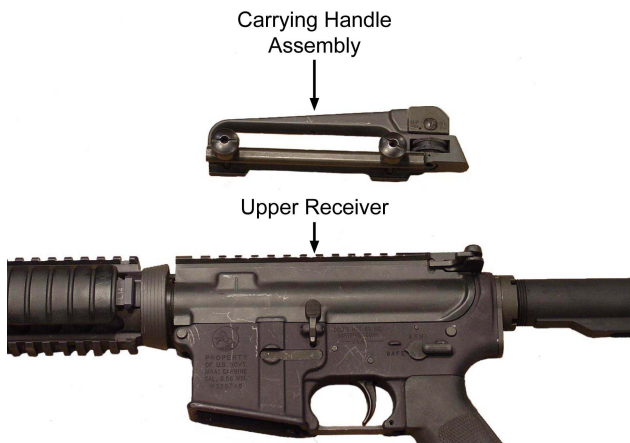

Figure 3-5. Clamping Bar and Carrying Handle Assembly

f. Charging Handle and Bolt Carrier Disassembly.

- (1) Pull back charging handle and bolt carrier. Refer to Figure 3-6.

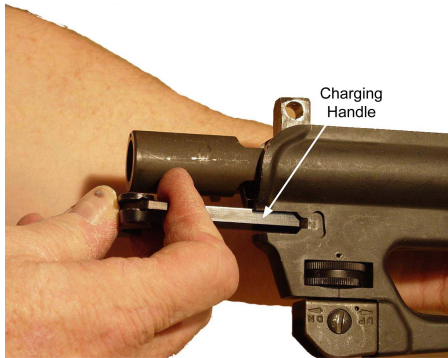

Figure 3-6. Charging Handle and Bolt Carrier Removal

- (2) Remove the bolt carrier and bolt. Refer to Figure 3-7.

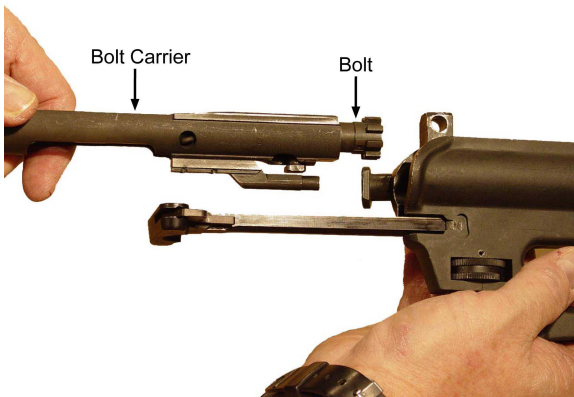

Figure 3-7. Bolt Carrier and Bolt

- (3) Remove the charging handle. Refer to Figure 3-8.

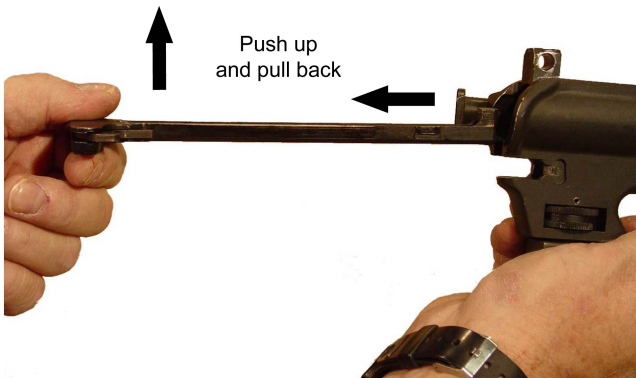

Figure 3-8. Charging Handle Removal

3-3. BOLT CARRIER DISASSEMBLY.

- a. Firing Pin Removal.

- (1) Remove firing pin retaining pin. Refer to Figure 3-9.

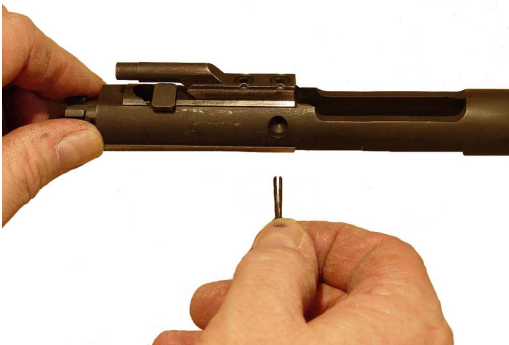

Figure 3-9. Firing Pin Retaining Pin Removal

- (2) Push bolt assembly to locked position. Refer to Figure 3-10.

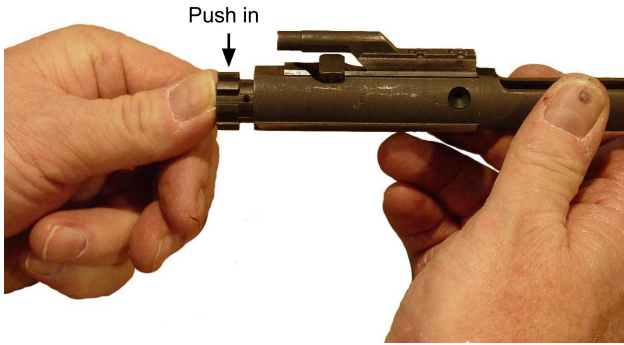

Figure 3-10. Bolt Assembly to Locked Position

- (3) Drop firing pin out rear of bolt carrier. Refer to Figure 3-11.

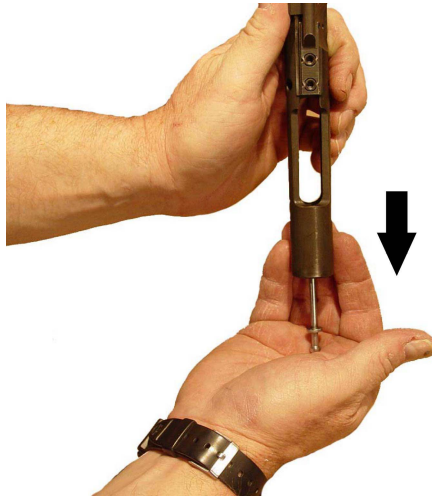

Figure 3-11. Removing Firing Pin from Bolt Carrier

- (4) To remove the bolt cam pin, turn the bolt carrier upside and tap the bolt carrier against palm of hand. Bolt cam pin will fall out. Refer to Figure 3-12.

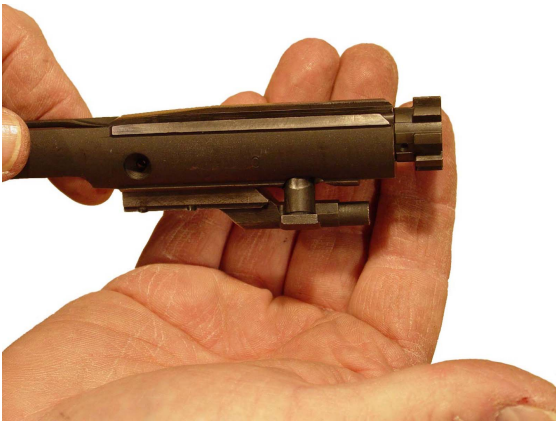

Figure 3-12. Bolt Cam Pin Removal

- (5) Remove bolt assembly from carrier. Refer to Figure 3-13.



Figure 3-13. Bolt Assembly Removal

b. Extractor Removal.



DO NOT DAMAGE TIP OF FIRING PIN WHEN PUSHING OUT EXTRACTOR PIN. REFER TO FIGURE 3-14.

NOTE

PRESS REAR OF EXTRACTOR TO CHECK SPRING FUNCTION. IF SPRING IS WEAK, CONTACT UNIT ARMORER.

- (1) Remove extractor pin using firing pin. Refer to Figure 3-14.

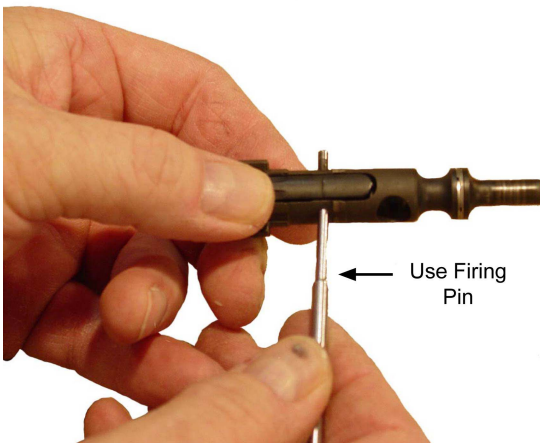

Figure 3-14. Checking Spring Function

- (2) Remove extractor and spring assembly. Refer to Figure 3-15.



Figure 3-15. Extractor Removal

3-4. LOWER RECEIVER DISASSEMBLY.

a. Buffer Assembly Removal.

- (1) Press in buffer, depress retainer and release buffer. Refer to Figure 3-16.



Figure 3-16. Buffer Assembly

- (2) Remove buffer and action spring. Refer to Figure 3-17.



Figure 3-17. Buffer and Action Spring

NOTE

REMOVAL OF THE BUTTSTOCK OR PISTOL GRIP IS NOT AUTHORIZED BY THE OPERATOR.

b. Buttstock Removal - Carbine Only.

NOTE

THE CARBINE HAS A FOUR-POSITION BUTTSTOCK: CLOSED, 1/2-OPEN, 3/4-OPEN AND FULL OPEN.

- (1) Extend buttstock assembly.
- (2) Grasp the lock release lever in the area of the retaining nut.
- (3) Pull downward on rear of lock release lever.
- (4) Slide buttstock to the rear to separate the buttstock assembly from the lower receiver extension. Refer to Figure 3-18.

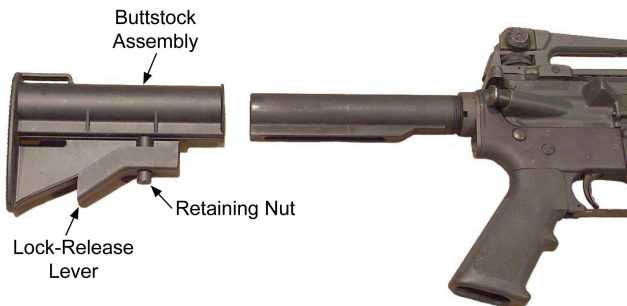

Figure 3-18. M4 / M4A1 CQBW Buttstock Assembly

NOTE

NO FURTHER DISASSEMBLY IS ALLOWED.

3-5. LOWER RECEIVER REASSEMBLY.

a. M4A1 CQBW and M4.

- (1) Grasp the lock release lever in the area of the retaining nut.
- (2) Pull to reinstall the buttstock assembly onto the lower receiver extension. Refer to Figure 3-19.

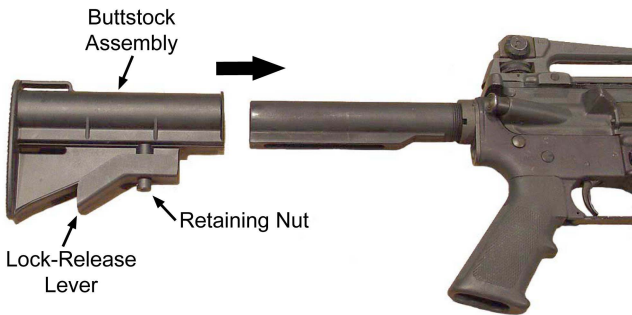

Figure 3-19. Reinstalling Buttstock Assembly

b. Insert action spring and buffer.

3-6. BOLT CARRIER REASSEMBLY.

- a. Reassemble extractor and spring.

NOTE

EXTRACTOR ASSEMBLY HAS A RUBBER INSERT WITHIN THE SPRING. USE CARE TO PREVENT LOSS OF THE INSERT.

- b. If the spring comes loose, place the large end of the spring in the extractor and seat it. Refer to Figure 3-20.



Figure 3-20. Extractor and Rubber Insert

NOTE

PRESS REAR OF EXTRACTOR TO CHECK SPRING FUNCTION. IF SPRING IS WEAK, CONTACT UNIT ARMORER.

- c. Insert extractor and spring. Refer to Figure 3-15.
- d. Push in extractor pin.

NOTE

IF RING GAPS ARE NOT STAGGERED WEAPON ACCURACY WILL BE AFFECTED.

- e. Stagger ring gaps to stop gas loss. Refer to Figure 3-21.



Figure 3-21. Ring Gaps

WARNING

DO NOT SWITCH BOLTS BETWEEN WEAPONS.

- f. Slide bolt into carrier. Refer to Figure 3-22.



Figure 3-22. Bolt into Carrier

WARNING

ENSURE THE CAM PIN IS INSTALLED IN THE BOLT GROUP. IF THE CAM PIN IS NOT INSTALLED, THE WEAPON WILL STILL FIRE AND EXPLODE.

- g. Replace bolt cam pin.
- h. Drop in and seat firing pin. Refer to Figure 3-23.



Figure 3-23. Seat Firing Pin

- i. Pull bolt forward. Refer to Figure 3-24.

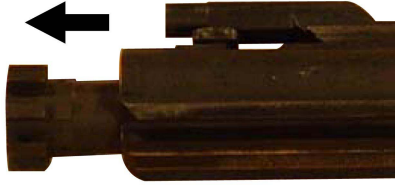

Figure 3-24. Bolt in Forward Position

NOTE

FIRING PIN SHOULD NOT FALL OUT WHEN BOLT CARRIER GROUP IS TURNED UPSIDE DOWN.

- j. Replace firing pin retaining pin. Refer to Figure 3-25.

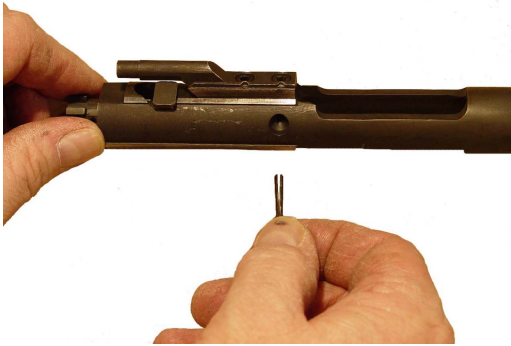

Figure 3-25. Install Firing Pin Retaining Pin

3-7. UPPER RECEIVER REASSEMBLY.

- a. Engage charging handle and then push in part way.
Refer to Figure 3-26.



Figure 3-26. Charging Handle

- b. Slide in bolt carrier group. Refer to Figure 3-27.

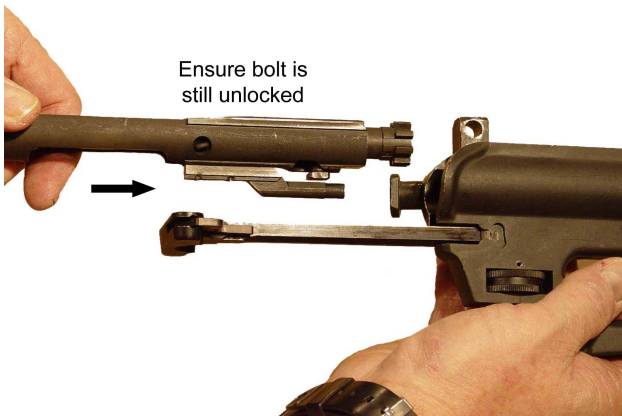

Figure 3-27. Bolt Carrier Group

- c. Push charging handle and bolt carrier group together. Refer to Figure 3-28.

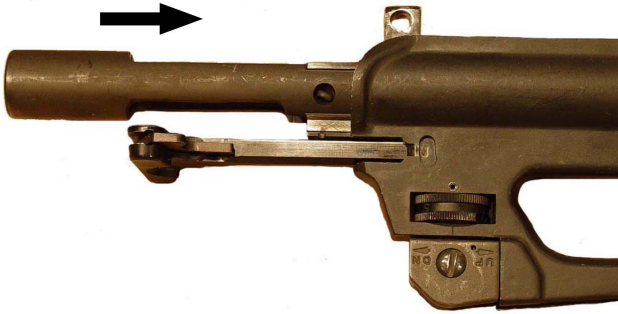

Figure 3-28. Charging Handle and Bolt Carrier Group

- d. Join upper and lower receivers. Refer to Figure 3-29.

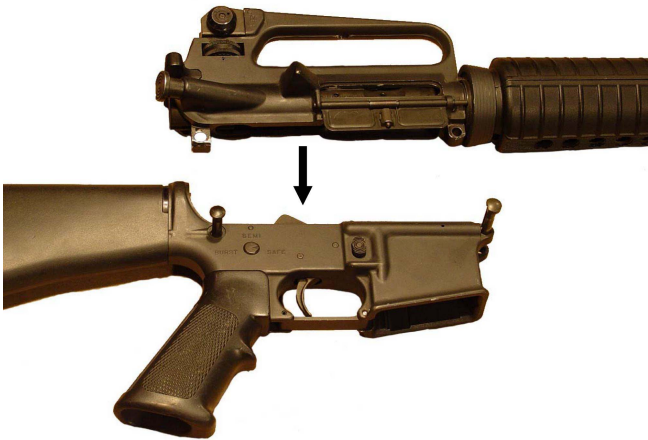

Figure 3-29. Join Upper and Lower Receivers

- e. Engage receiver pivot pin. Refer to Figure 3-30.



Figure 3-30. Engage Receiver Pivot Pin

CAUTION

SELECTOR LEVER MUST BE ON SAFE OR SEMI BEFORE CLOSING UPPER RECEIVER.

- f. Close upper and lower receiver groups. Push in takedown pin.

NOTE

THE ROUND HANDGUARDS ARE IDENTICAL AND CAN BE INTERCHANGED (TOP OR BOTTOM).

- g. Place the weapon on the buttstock and press down on the slip ring with both hands. Using the “Buddy System”, have a partner install one handguard on top and one on the bottom. Refer to Figure 3-31.



Figure 3-31. Apply Handguards Using the “Buddy System”

- h. Install sling.



IF THE ROUND NUTS AND THE CLAMPING BAR ARE INADVERTENTLY REMOVED, THE CLAMPING BAR MUST BE REINSTALLED ON THE THREADED STUDS IN A MANNER NOT TO PROTRUDE PAST THE FRONT OF THE CARRYING HANDLE. THE ROUND NUTS SHOULD BE REINSTALLED ON THE THREADED STUDS BY AN ARMORER ONLY.

- i. Reinstall the carrying handle assembly with the front stud positioned into the notch in front of the upper receiver mounting surface.
- j. Hold the carrying handle assembly flat against the top of the upper receiver.
- k. Slide the clamping bar against the receiver with the lower edge underneath the slotted portion.
- l. Using finger pressure only, firmly tighten both round nuts.

3-8. MAGAZINE.

a. Disassembly.

- (1) Release the base catch with the end of a cleaning rod. Refer to Figure 3-32.

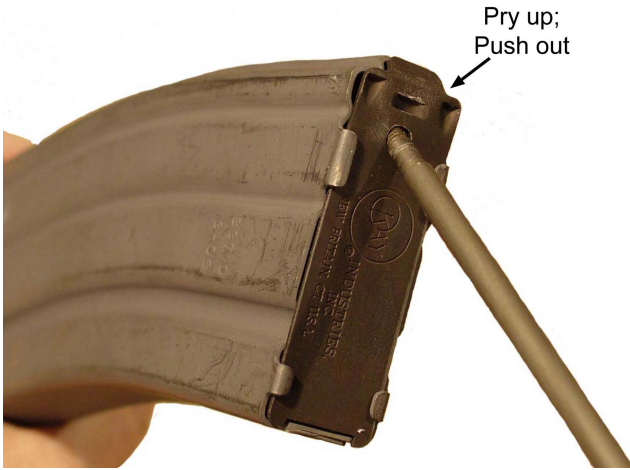

Figure 3-32. Release Magazine Base Catch

- (2) Remove the magazine base. Refer to Figure 3-33.



Figure 3-33. Magazine Base Removal

- (3) Manipulate spring and follower to remove. Refer to Figure 3-34.

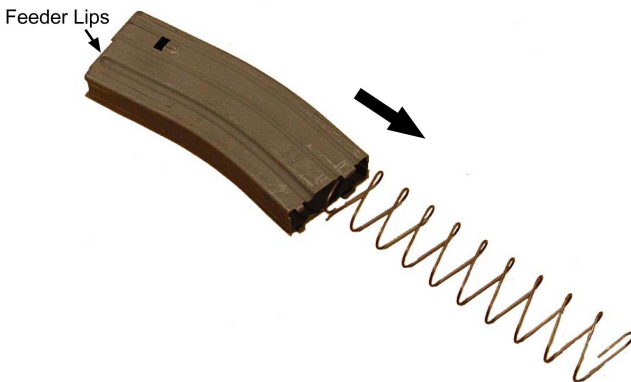

Figure 3-34. Magazine Spring and Follower

b. Inspection.

- (1) Inspect feeder lips for damage. If damaged or bent, replace magazine.
- (2) Inspect for corrosion.

NOTE

DO NOT REMOVE FOLLOWER FROM SPRING.

c. Assembly.

NOTE

IF THE SPRING COMES LOOSE FROM THE FOLLOWER, DO NOT ATTEMPT REPAIR. TURN THE PIECES INTO THE UNIT ARMORER.

- (1) Clean and lubricate the magazine with Cleaner, Lubricant, Preservative (CLP). Wipe dirt from tube, spring and follower; then lightly lubricate spring.
- (2) Insert follower and manipulate spring to install. Refer to Figure 3-35.

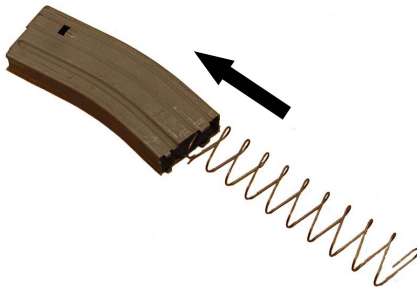

Figure 3-35. Insert Spring and Follower into Magazine

NOTE

PRINTING ON BASE MUST BE ON THE OUTSIDE.

- (3) Slide the base under all four tabs until base catches. Refer to Figure 3-36.



Figure 3-36. Replacing Magazine Base

3-9. RAIL ADAPTER SYSTEMS (RAS).

WARNING

CONFIRM THE WEAPON IS UNLOADED AND ON SAFE BEFORE PERFORMING THE FOLLOWING PROCEDURES.

NOTE

THE UPPER RAS ASSEMBLY WILL BE REMOVED AND INSTALLED BY AN ARMORER ONLY.

DO NOT REMOVE THE UPPER RAS FOR ROUTINE CLEANING. THIS MAY CAUSE THE ZERO OF ATTACHED SIGHTING ACCESSORIES TO SHIFT WHEN THE UPPER RAS IS REINSTALLED.

- a. Disassembly of Handguards for Rifle and Carbine.
 - (1) To remove handguard sections press the spring latch located on the end of the handguard section. Refer to Figure 3-37.



Figure 3-37. Handguards

- (2) To remove the side and bottom sections, press the spring latch and move toward muzzle end.

- (3) Upper sections are removed by pressing the spring latch and sliding the sections to the rear of the upper receiver group. Refer to Figure 3-38.

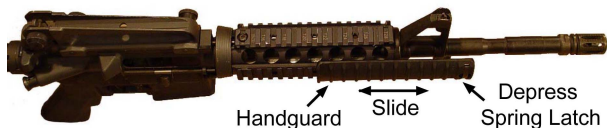

Figure 3-38. Upper Handguard Sections

b. Inspection.

- (1) When cleaning the weapon and / or when handguards or accessories are being installed or repositioned; clean, inspect and lubricate the rail surfaces and recoil grooves (slots) of the RAS with CLP.
- (2) Use the general purpose brush, from the standard weapon cleaning kit, to clean the RAS and handguard sections.
- (3) If debris is observed inside the RAS, remove the lower RAS assembly or the M203 Grenade Launcher and detail clean. Thoroughly clean the inner surface of the thermal liner to maintain the heat reflective surface.
- (4) If the RAS is exposed to salt water or corrosive chemicals, thoroughly rinse the upper and lower assemblies in fresh water as soon as the tactical situation allows. Thoroughly clean, inspect and lubricate as required, including the spring latches in the handguard sections.
- (5) Clean and inspect the handguard sections and the rail grabbers of accessories to be mounted prior to embarking on tactical operations or training events.



DO NOT APPLY LUBRICANT TO THE PLASTIC SURFACES OF THE HANDGUARD SECTIONS.

- (6) Clean handguard sections with an absorbent cloth.

c. Assembly.



DO NOT REMOVE THE THERMAL LINER FROM THE LOWER RAS ASSEMBLY.

- (1) Confirm the arrow on the inner surface points towards the muzzle of the weapon.
- (2) Install the lower RAS assembly by inserting the front edges into the forward handguard cap at the angle shown in Figure 3-39.
- (3) Compress the rear handguard slip ring while pivoting the lower RAS assembly up and into the final position. Refer to Figure 3-39.

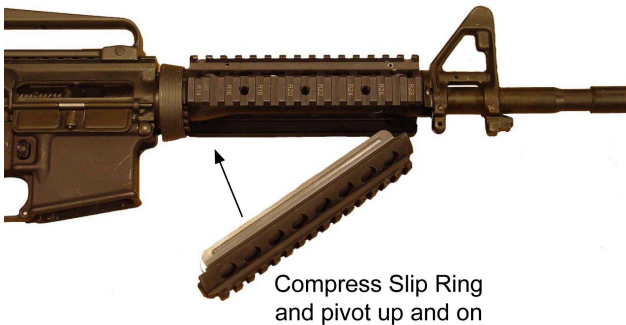

Figure 3-39. Lower RAS Assembly

- (4) Release the rear handguard slip ring.
- (5) Confirm the slip ring engages around the rear flange of the lower RAS assembly.

NOTE

HANDGUARD SECTIONS ARE QUICKLY ATTACHED AND DETACHED FROM THE RAS. A SPRING LATCH AT ONE END OF EACH HANDGUARD SECTION AUTOMATICALLY ENGAGES CUTOUTS POSITIONED AT EITHER END OF THE FOUR RAIL SECTIONS. TO SLIDE A HANDGUARD SECTION BEYOND A CUTOUT, OR TO REMOVE IT, SLIDE THE SECTION IN THE DESIRED DIRECTION WHILE APPLYING THUMB PRESSURE TO THE SPRING LATCH.

- (6) Install the handguard sections from the muzzle end of the RAS.
- (7) Longer handguard sections on carbines should be oriented with spring latch toward muzzle. Longer handguard sections on rifles should be oriented with spring latch toward chamber.
- (8) Install the handguard sections from the rear of the upper receiver group.

NOTES

ALL HANDGUARD SECTIONS ARE INTER-CHANGEABLE BETWEEN RIFLES AND CARBINES.

THE SPRING LATCH WILL ENGAGE AND SECURE CUTOUTS WHEN THEY MEET AT EITHER END OF THE RAILS. INSTALL SHORTER HANDGUARD SECTIONS, USED ON RAILS PARTIALLY OCCUPIED BY ACCESSORIES, WITH THE SPRING LATCHES POSITIONED AWAY FROM THE ACCESSORIES.

3-10. RAS ACCESSORY MOUNTING PROCEDURES.

- a. Numbered Recoil Grooves. Each RAS rail is sequentially numbered within the recoil grooves. The top rail numbers have a "T" prefix. The bottom rail number, to the operator's left, has an "L" prefix. The numbers and prefixes assist in remounting an accessory in the same position (memory aid) and to provide an address for every position on the system. The addresses explain precisely where to mount certain accessories and which addresses are incompatible with other accessories.
- b. RAS. Each rail contains holes threaded 1/4-inch-20 TPI (standard camera adapter size) within recoil grooves along the length. The holes are provided for the attachment of standard camera / video accessories, if required. An RAS equipped weapon, accessorized with a large, heavy night vision device can be mounted on a standard camera tripod for extended hands-off surveillance missions.
- c. Standard Sling Adapter. The standard side sling adapter, if installed, must be positioned with the sling swivel to the operator's right (right side of the weapon. It will be oriented with the integral stop to the rear. This allows the swivel to fold flat towards the muzzle preventing the side sling adapter from interfering with the installation of the handguard sections, the forward handgrip or other accessories requiring installation from the end of the rail. Refer to Figure 3-40.

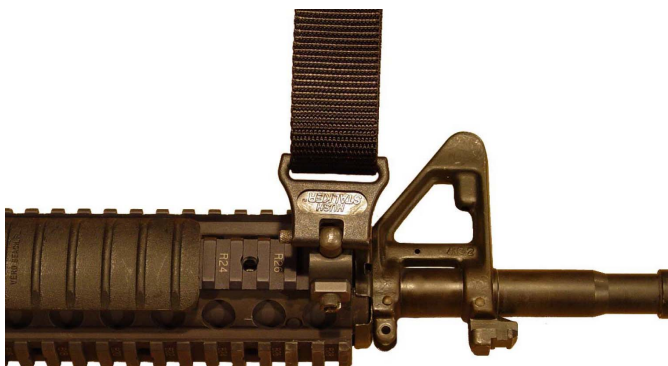

Figure 3-40. Standard Side Sling Adapter

3-11. COMPENSATOR.



DO NOT REMOVE THE COMPENSATOR FOR ANY REASON. ARMORERS ARE NOT AUTHORIZED TO REMOVE IT FOR CLEANING PURPOSES.

The compensator has five slots. The third or middle slot must be straight up and should line up with the front sight post. Refer to Figure 3-41.



Figure 3-41. 5.56mm Compensator

3-12. M15A2 / M23 BLANK FIRING ATTACHMENT (BFA).

WARNING

USE ONLY BLANK ROUND, M200 AMMUNITION WITH THE BFA.

NOTE

M15A2 BFA IS PAINTED RED AND USED ON THE M16A2 AND M16A4 RIFLES. M23 BFA IS PAINTED YELLOW AND STAMPED “M4 CARBINE ONLY”, AND USED ON THE M4 AND M4A1 CQBW CARBINES.

1. Unscrew and slide all the way to the back. Refer to Figure 3-42.



Figure 3-42. M15A2 Blank Firing Attachment (BFA)

2. Hook the BFA behind first groove of compensator. Refer to Figure 3-43.

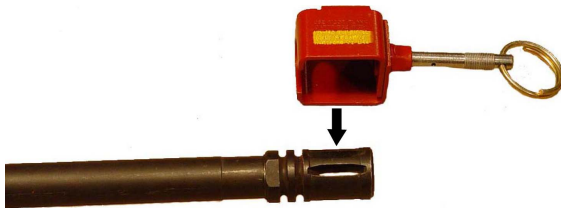

Figure 3-43. Compensator with M15A2 BFA



DO NOT USE TOOLS TO TIGHTEN THE BFA ATTACHMENT; HAND TIGHTEN ONLY.

NOTE

AFTER FIRING 50 ROUNDS, ENSURE THE ATTACHMENT IS STILL TIGHT. CLEAN CARBON BUILD-UP AFTER EACH USE.

3. Slide the BFA into the compensator and hand tighten. Refer to Figure 3-44.



Figure 3-44. M15A2 BFA Attached to Compensator

3-13. QUICK ATTACH / DETACH (QD) SOUND SUPPRESSOR.

WARNINGS

THE QD SUPPRESSOR MUST ONLY BE USED WITH THE M4A1 CQBW.

THE QD SUPPRESSOR MUST ONLY BE USED WITH THE QUICK DETACH COMPENSATOR.

CONFIRM THE WEAPON IS UNLOADED AND ON SAFE BEFORE PERFORMING THE FOLLOWING PROCEDURES.

WARNING

AFTER USE, THE QD SUPPRESSOR WILL BE EXTREMELY HOT. TO REMOVE THE QD SUPPRESSOR WHILE HOT, USE A BAYONET OR OTHER AVAILABLE TOOLS TO ROTATE THE RETAINER RING AND DISENGAGE THE QD LATCH PLATE. WEAR HEAT-RESISTANT GLOVES WHEN HANDLING HOT SUPPRESSORS.

NOTE

ALL INSTRUCTIONS AND / OR DIRECTIONS OF MOTION ARE FROM THE REAR OF THE WEAPON OR SUPPRESSOR WITH THE MUZZLE END POINTED AWAY FROM THE OPERATOR.

a. Disassembly.

- (1) From the rear of the weapon (muzzle pointed away from the operator), raise the quick-detach locking latch on the QD suppressor and slide off the barrel. Refer to Figure 3-45.



Figure 3-45. QD Suppressor Locking Latch

- (2) Twist the QD suppressor during removal. This allows the carbon cutting grooves to dislodge the carbon and metal fouling build-up in the QD compensator / QD suppressor interface surfaces.

b. Inspection.

- (1) Inspect the suppressor for missing parts. If missing parts are identified, notify unit armorer.
- (2) Inspect the compensator for looseness. If loose, notify unit armorer.

c. Assembly.

WARNING

CONFIRM THE WEAPON IS UNLOADED AND ON SAFE BEFORE PERFORMING THE FOLLOWING PROCEDURES.

- (1) Rotate the retainer ring clockwise (to the right) until it stops with the tab in approximately the 9 o'clock position. Raise the quick-detach latch plate and slide the QD suppressor over the QD compensator. Rotate the QD suppressor counterclockwise (to the left) until the rotational stop is engaged at the front of the QD model compensator. Refer to Figure 3-46.

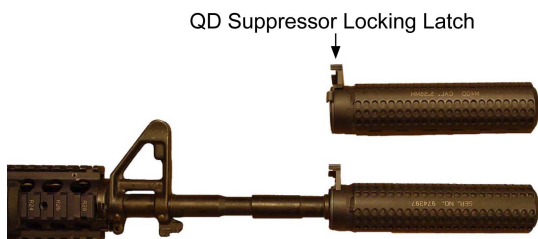

Figure 3-46. QD Suppressor Mounted to Compensator

- (2) Hold the suppressor firmly to the rear and against the rotational stop in the QD compensator. Lower the QD latch plate until nearly flush, at the 12 o'clock position, with the top surface of the suppressor body. Refer to Figure 3-47.



Figure 3-47. QD Suppressor Latch Plate

- (3) Rotate the retainer ring counterclockwise (to the left) until it passes the 6 o'clock position and stops against the latch plate. The QD latch plate should now be secured in the down / locked position.

WARNINGS

WEAR EYE PROTECTION WHEN OPERATING THE WEAPON WITH THE SUPPRESSOR ATTACHED. ESPECIALLY IF THE OPERATOR FIRES LEFT HANDED OR IF WATER IS PLACED IN THE SUPPRESSOR TO HELP REDUCE FIRST ROUND MUZZLE FLASH.

LIMIT FIRING TO SEMI-AUTOMATIC OR BURST FIRE EXCEPT IN EMERGENCIES. DO NOT SUBJECT THE MODEL QD SUPPRESSOR TO MORE THAN 90 ROUNDS OF CONTINUOUS AUTOMATIC FIRE. IF THIS LIMIT IS REACHED, ALLOW THE UNIT TO COOL BEFORE RESUMING FIRE, IF THE TACTICAL SITUATION PERMITS. UP TO 15 ROUNDS PER MINUTE OF CONTINUAL FIRE IS ACCEPTABLE. FULL AUTOMATIC FIRING WILL CAUSE EXCESSIVE FUMES.

**3-14. M4 / MODEL QD SOUND SUPPRESSOR
MAINTENANCE.**

WARNING

AFTER USE, THE QD SUPPRESSOR WILL BE EXTREMELY HOT. TO REMOVE THE QD SUPPRESSOR WHILE HOT, USE A BAYONET OR OTHER AVAILABLE TOOLS TO ROTATE THE RETAINER RING AND DISENGAGE THE QD LATCH PLATE. WEAR HEAT RESISTANT GLOVES WHEN HANDLING HOT SUPPRESSORS.

- a. Remove the QD suppressor while hot. Carbon fouling solidifies as the unit cools making removal more difficult.
- b. Remove the suppressor temporarily from the barrel if fired frequently over a period of time.
- c. Twisting during removal after each firing event allows the carbon cutting grooves to function and thereby minimizes the accumulated buildup of metal and carbon fouling that could make removal more difficult later.

**3-15. M4 / MODEL QD SOUND SUPPRESSOR
CLEANING.**

Clean the M4A1 CQBW QD sound suppressor and compensator using the following methods:

- a. Mount and dismount the suppressor to / from the weapon several times using a twisting motion. This enables the compensator's carbon cutting grooves to dislodge carbon and metal fouling build-up.
- b. Dry brush loosened residue from parts using the general purpose (GP) toothbrush from the weapon

cleaning kit. Orient the parts to prevent carbon from falling into the suppressor body.

- c. CLP will be used to remove copper fouling from both the QD compensator and the corresponding internal QD suppressor surfaces, which contact the compensator.



DO NOT USE WIRE BRUSHES.

- d. Use the short nylon bristles of the general purpose brush to scrub parts clean.



DO NOT ALLOW CLP TO FLOW DOWN INTO THE SUPPRESSOR BODY AND CONTAMINATE THE INTERNAL BAFFLE AREAS. CLP AND OTHER OILY RESIDUES IN THE SUPPRESSOR BODY WILL CAUSE EXCESSIVE SMOKE WHEN THE WEAPON IS FIRED.

- e. Clean and dry the CLP-affected parts with an absorbent cloth.

3-16. QD SOUND SUPPRESSOR LUBRICATION.

NOTES

IF CLP HAS ENTERED THE SUPPRESSOR, THE SUPPRESSOR SHOULD BE THOROUGHLY SOAKED AND AGITATED VIGOROUSLY IN WARM SOAPY WATER. RINSE IN CLEAR, FRESH WATER AND AIR DRY.

THE INTERIOR OF THE QD SUPPRESSOR MUST BE THOROUGHLY DRY BEFORE USING. THE USE OF COMPRESSED AIR OR BLOWER DRYER IS RECOMMENDED.

TM 05538/10012-10A/1

- a. Do not oil the QD suppressor body; wipe it dry with a clean cloth.
- b. Apply only a light coat of CLP to the QD compensator to prevent corrosion each time the weapon is cleaned.
- c. Apply a very light coat of CLP to the suppressor latch plate legs to smooth operation.

3-17. M203 GRENADE LAUNCHER / M16A4 RIFLE / M4A1 CBQW OPERATIONAL NOTES.

NOTES

THE WEAPON'S ZERO COULD CHANGE WHEN THE M203 IS ATTACHED DUE TO THE MASS ADDED TO THE WEAPON BY THE GRENADE LAUNCHER. THIS IS A NORMAL CONDITION AND CAN BE COMPENSATED FOR BY THE OPERATOR.

KNOW AND REMEMBER THE WEAPON'S ZERO BOTH WITH THE M203 ATTACHED AND UNATTACHED.

- a. The 5-rib handguard section covering the forward recoil grooves of the upper RAS assembly's left-hand rail should be removed and stored in the weapon's buttstock when the M203 is mounted.
- b. Configure the left-hand rail with a single 11-rib handguard section fully to the rear. Latch in the groove closest to the handguard slip ring.
- c. Removing the 5-rib handguard section will ensure the M203's barrel latch will depress fully and expose recoil groove L-30. If the forward section of the left-hand rail is to be covered, use a short handguard section (4-rib or less). The handguard section will not

block the M203 barrel latch from being fully depressed.

- d. A shorter handguard section should be latched into groove L-37.

3-18. EO TECH SIGHT.

The EO Tech sight enables operators to engage targets at normal small arms ranges during ingress to and egress from the objective area, and at ranges of 25meters or less in confined spaces while minimizing the possibility of injury to noncombatants.

- a. Disassembly.

- (1) Remove the sight by unscrewing the knob located on the left side of the sight.
- (2) Remember rail location. Refer to Figure 3-48 and Figure 3-49.



Figure 3-48. EO TECH Sight – Left View



Figure 3-49. EO TECH Sight – Right View

b. Inspection.

- (1) Remove sight and mount away from rail surface.
- (2) Clean as required.

c. Assembly.

- (1) Reinstall the EOTech sight in the same location on the rail.
- (2) Tighten the knob.

3-19. VISIBLE LIGHT ILLUMINATOR (VLI).

The Visible Light Illuminator (VLI) is a powerful flashlight that projects a wide-angle beam. The concentrated central beam of white light is used for searching, acquisition, identification and momentary dazzling targets in any low light environment.

a. Assembly.

- (1) Loosen the mounting knob. The knob has normal right hand threads.

- (2) Turn the knob counterclockwise (approximately 5 or 6 full turns from full closed position) until a positive stop is felt. Refer to Figure 3-50.

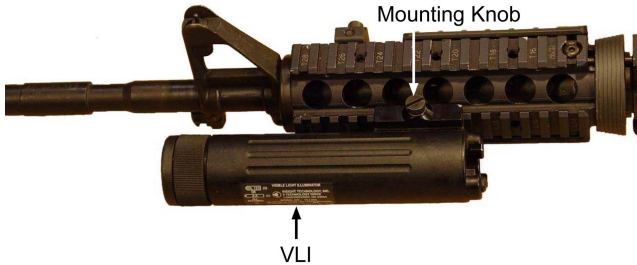

Figure 3-50. Mounting Visible Light Illuminator

b. Inspection.

- (1) Inspect rail surface, VLI and mount for burrs.
- (2) Clean as required.

c. Disassembly.

- (1) Remove the light by unscrewing the knobs.
- (2) Remove the light and mount away from rail surface.
- (3) Place the sight mount assembly on the rail surface.
- (4) Hook the right side of the base mount clamp on the right edge of the weapon rail. With a pivoting motion, engage the round stud into the top mounting surface of the rail on the weapon. Apply slight pressure and tighten the knob.

**Section III. SCHEDULED MAINTENANCE
SERVICES**

3-20. GENERAL CLEANING INFORMATION.



DO NOT MIX LUBRICANTS ON THE SAME WEAPON. THE WEAPON MUST BE THOROUGHLY CLEANED DURING CHANGE FROM ONE LUBRICANT TO ANOTHER. DRY CLEANING SOLVENT (SD) IS RECOMMENDED FOR CLEANING DURING CHANGE FROM ONE LUBRICANT TO ANOTHER.

When the term CLP (Cleaner, Lubricant, and Preservative) or the word lubricant is cited in this TM, it is to be interpreted to mean that CLP, LSA (Lubricating Oil, Semi-fluid, Automatic Weapons) or LAW (Lubricant, Artic Weather) can be utilized as applicable.

- a. With the weapon disassembled, thoroughly clean, inspect and lubricate.
- b. Always shake CLP before use.
- c. After firing, clean the weapon with CLP according to instructions in paragraph 3-21. Wipe dry and lube according to lubrication instructions.

NOTE

IF PARTS FROM THE CLEANING KIT ARE MISSING OR DEFECTIVE, CONTACT THE UNIT ARMORER.

- d. Cleaning materials (swabs, pipe cleaners and CLP) are expendable items. Refer to Figure 3-51. A complete list of cleaning materials is listed in Appendix B.



Figure 3-51. Standard Cleaning Kit

3-21. FIELD EXPEDIENT CLEANING.

NOTE

AFTER CLEANING AND BEFORE REASSEMBLY,
LIGHTLY LUBRICATE LUGS IN BARREL
EXTENSION WITH CLP.

- a. Clear the weapon (paragraph 2-9).
- b. Check bore and chamber for fouling.
- c. Remove bolt carrier group (paragraph 3-3.).
- d. Clean carbon and oil from firing pin and all surfaces of bolt / carrier with dry swabs.
- e. Clean firing pin hole and bolt carrier key with pipe cleaner.
- f. Apply light coating of CLP. Pay special attention to slide and cam pin area. Refer to Figure 3-52.

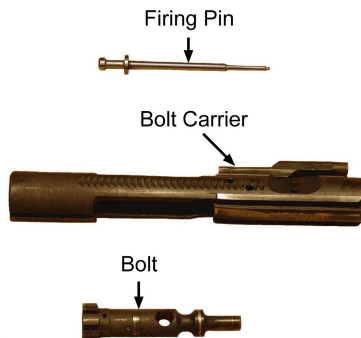

Figure 3-52. Bolt Carrier Group



DO NOT BEND OR FLEX THE CLEANING ROD. ENSURE THE SWAB GOES COMPLETELY THROUGH THE COMPENSATOR. DO NOT REVERSE DIRECTION WHILE SWAB IS IN BORE OR COMPENSATOR.

- g. Swab out the weapon from chamber to muzzle.

3-22. DETAILED CLEANING TECHNIQUES.



DO NOT INTERCHANGE PARTS FROM ONE WEAPON WITH ANOTHER WEAPON.

- a. The bore of the M16A2 has lands and grooves called rifling. Rifling makes the bullet spin very rapidly as it moves down the bore and down range.
- b. As the rifling twists rapidly, it is easier to pull the bore brush through the bore. Allow the bore brush to turn as it is pulled through for better cleaning of the grooves (tracking). Follow the procedures below:
 - (1) Connect three sections of rod, leaving each section approximately two turns short of being tight.
 - (2) Swab out the bore with a patch moistened with CLP.
 - (3) Attach the bore brush, leaving it two turns short of being tight.

NOTE

THE CLEANING PROCESS WILL GO MORE QUICKLY USING THE “BUDDY SYSTEM” ON THE CLEANING RODS. SET UP ONE ROD WITH A PATCH HOLDER AND THE OTHER WITH A BORE BRUSH.

- (4) Point the muzzle down. Holding the upper receiver in one hand, insert the end of the rod without the bore brush into the chamber. Allow the rod to fall straight through the bore. Approximately 2-3 inches will be sticking out of the muzzle.
- (5) Attach the handle section of the cleaning rod to the end of rod sticking out of the muzzle.
- (6) Pull the bore brush through the bore and out the muzzle. The rod will twist as it is pulled through. Refer to Figure 3-53.

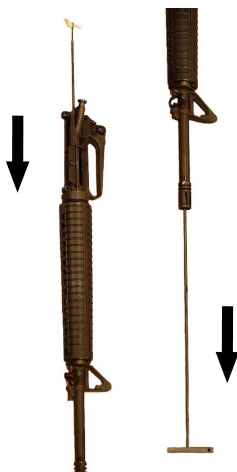

Figure 3-53. Swabbing Weapon

- (7) After one pull, remove the handle section and repeat the process. After three or four pulls, the three rod sections are tightened together. Loosen the rod sections and bore brush and repeat the process.
- (8) Send a patch through the bore occasionally to help remove the dirt and debris the bore brush is working loose. The same technique, as described above, can be used to save time. Replace the bore brush with the rod tip (patch holder) and a wet patch. Drop it through. The handle is not required to pull only a patch through. Always have the bore wet with cleaner before trying to pull a bore brush through.

3-23. THOROUGH CLEANING.

a. Upper Receiver. Clean with CLP:

- (1) All areas of powder fouling, corrosion, dirt and rust.

- (2) Locking lugs, chamber and gas tube. Refer to Figures 3-54 and 3-55.

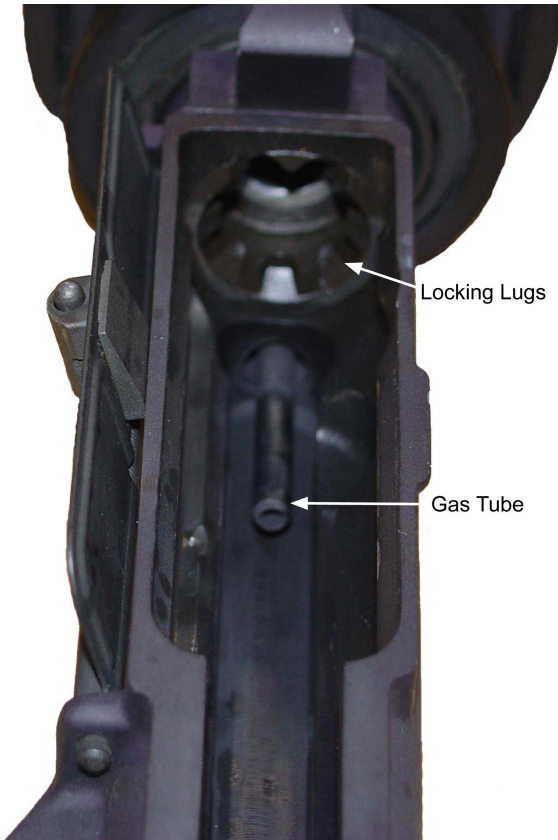

Figure 3-54. Locking Lugs and Gas Tube



Figure 3-55. Cleaning Chamber and Locking Lugs

- (4) Bore. Starting at the receiver, drop the rod and brush through the chamber and pull through the compensator.



DO NOT REMOVE INNER HEAT SHIELD.

- (5) Handguards. Remove and wipe with cloth.
- (6) Front and rear sight. Clean with brush and CLP.
- (7) Compensator. Scrub with brush and clean between compensator slots.
- (8) When using the bore brush, do not reverse direction while in bore.

b. Bolt Carrier Group.

Refer to paragraph 3-3. for disassembly.

NOTE

USE WELL-WORN BORE BRUSH ONLY.

- (1) Outer and inner surfaces of bolt carrier.
- (2) Carrier key. After dislodging carbon deposits and dirt with worn bore brush, clean with pipe cleaner. Refer to Figure 3-56.



Figure 3-56. Carrier Key

- (3) Firing pin recess and firing pin.

- (4) Firing pin hole (use pipe cleaner). Refer to Figure 3-57.

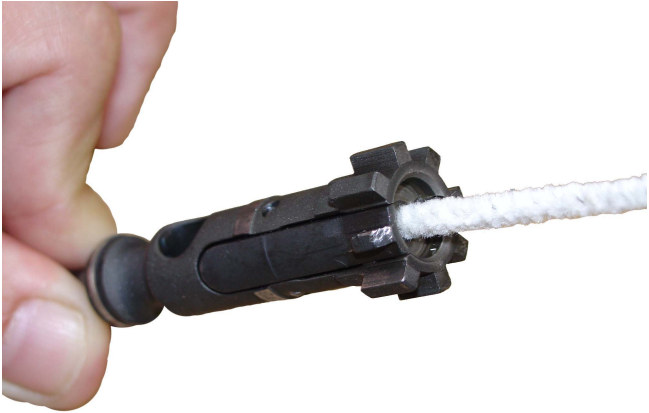

Figure 3-57. Cleaning the Firing Pin Hole

- (5) Carbon deposits and dirt from locking lugs. Refer to Figure 3-58.

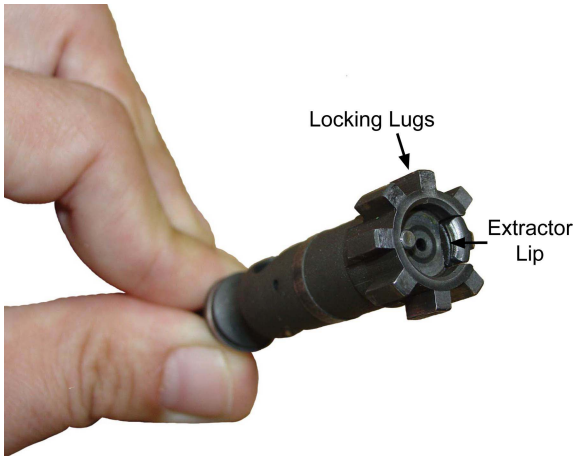

Figure 3-58. Locking Lugs and Extractor Lip

- (6) Areas behind bolt ring (refer to Figure 3-59) and under lip of extractor. Refer to Figure 3-58.



Figure 3-59. Bolt Rings

- c. Ejector. The design of the ejector makes disassembly for cleaning by the operator impractical. Follow the steps below on a monthly or as required (weekly if firing blanks) basis to ensure the weapon ejects empty cases clear of the operator and weapon.

- (1) Remove bolt from carrier.
- (2) Hold the bolt in hand as shown with ejector down and extractor up. Refer to Figure 3-60.

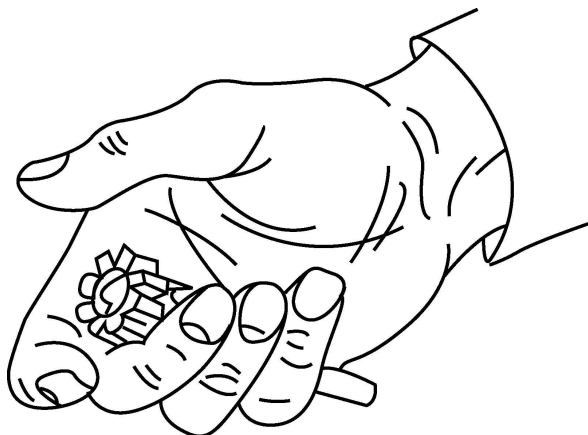

Figure 3-60. Ejector Cleaning

- (3) Place a few drops of CLP around the ejector to form a puddle.
- (4) Place a fired or dummy case under the lip of the extractor. Refer to Figure 3-61.
- (5) Using a rocking motion, press the case down against the ejector. The ejector is spring loaded and some resistance will be felt.
- (6) Press on the case until it stops against the bolt face.
- (7) Ease the pressure on the thumb slightly and press down again.
- (8) Repeat several times.
- (9) Replace the CLP frequently.
- (10) When the spring action of the ejector is smooth and strong, remove any excess CLP. Refer to Figure 3-61.

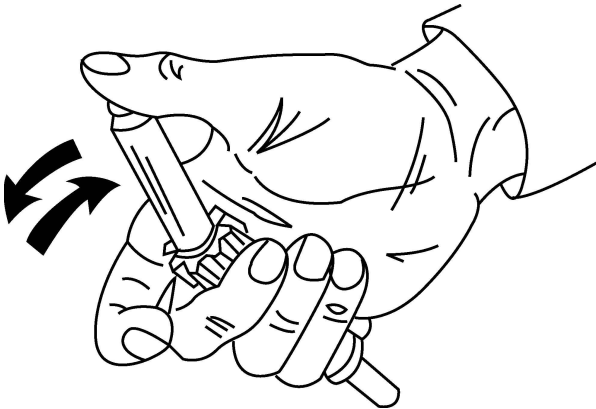

Figure 3-61. Lubricate Ejector

- d. Carrier Key. Clean well with pipe cleaner and CLP. Refer to Figure 3-62.

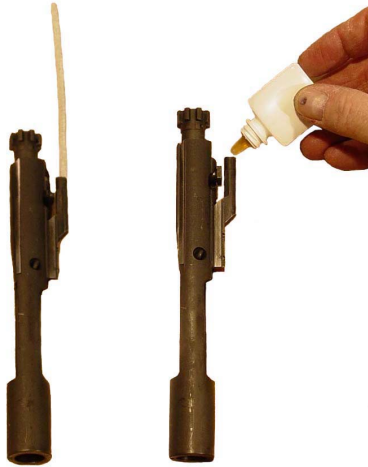

Figure 3-62. Lubricate Carrier Key

- e. Lower Receiver Group.
- (1) Remove all areas of powder, fouling, corrosion and dirt.
 - (2) Wipe dirt from trigger mechanism.
 - (3) Clean buffer, action spring and inside lower receiver extension.
 - (4) Clean lower receiver extension and buttstock.



DO NOT REMOVE INNER HEAT SHIELDS.

- f. Handguard.
 - (1) Remove handguards.
 - (2) Wipe with cloth and CLP.
- g. Front Sight. Clean with brush and CLP.
- h. Compensator. Scrub with brush and CLP between compensator slots.
- i. Rear Sight. Clean with brush and CLP.

3-24. INSPECT BEFORE LUBRICATING.

If items are found to be unsatisfactory during inspection, refer to higher level maintenance.



DO NOT INTERCHANGE BOLTS BETWEEN WEAPONS.

- a. Bolt. Inspect for cracks or fractures, especially in the cam pin hole and bolt lug area. Bolts containing pits extending into the firing pin hole need to be replaced.
- b. Firing Pin Retaining Pin. Inspect for bent or badly worn pin.
- c. Cam Pin. Inspect for cracked, chipped or missing pins.

- d. Firing Pin. Inspect for bent, cracked, blunted or sharp end.
- e. Extractor and Extractor Spring. Inspect extractor for chipped or broken edges in the area of the lip that engages the cartridge rim. Check inside the extractor spring to make sure the rubber insert is in place.

3-25. CLP - CLEANER, LUBRICANT AND PRESERVATIVE.

- a. CLP performs the following:
 - (1) Dissolves firing residue and carbon.
 - (2) Provides a layer of Teflon as it dries to provide lubrication.
 - (3) Prevents rust from forming.



DO NOT DRY CLEAN THE WEAPON. DO NOT USE HOT WATER OR OTHER SOLVENTS TO CLEAN THE WEAPON. THIS WILL REMOVE THE TEFLON LUBRICANT BUILT UP AS A RESULT OF USING CLP. IF CLP IS NOT USED, RBC MAY BE USED TO REMOVE CARBON WITHIN THE BORE.

- b. Use CLP as follows:
 - (1) Shake bottle well before each use.
 - (2) Place a few drops on a patch or rag.
 - (3) Clean the weapon with patches and rags until no residue is found.
 - (4) Use a patch or rag and apply a fresh, light coat.

3-26. LUBRICATION.

Under all but the coldest arctic conditions, CLP is the lubricant to be used on the weapon. Remove excessive lubricant from the bore and chamber before firing. For a lubricant guide, refer to Figure 3-63.

NOTE

DRY CLEANING SOLVENT MAY BE USED TO COMPLETELY REMOVE LUBRICANTS. WHEN MOVING TO EXTREME COLD WEATHER OPERATIONS, REMOVE TRACES OF CLP BEFORE APPLYING LAW.

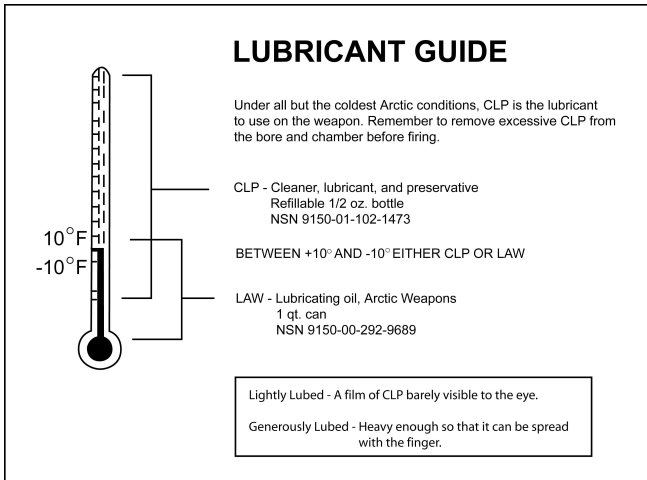

Figure 3-63. Lubricant Guide

a. Upper Receiver.

- (1) Lightly lubricate inside of upper receiver, bore and chamber, outer surfaces of barrel and front sight and surfaces under handguard.

- (2) Depress front sight detent and apply one drop CLP to front sight detent. Depress detent several times to work lubricant into the spring. Refer to Figure 3-64.



Figure 3-64. Lubricate Front Sight

b. M4A1 CQBW / M16A4 Upper Receiver and Carrying Handle.

- (1) Apply one or two drops of lubricant to both threaded studs.

- (2) Lightly lubricate the clamping bar and both round nuts. Refer to Figure 3-65.

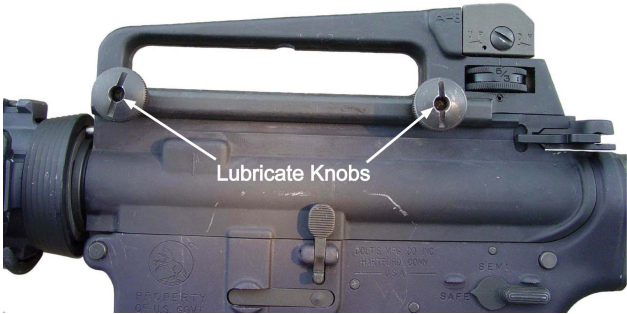

Figure 3-65. Lubricate Carrying Handle

- (3) Lightly lubricant the mating surfaces of the carrying handle assembly and upper receiver.

c. Bolt Carrier Group.

CAUTION

APPLY ONLY A LIGHT COAT OF CLP TO FIRING PIN AND FIRING PIN RECESS IN BOLT.

- (1) Dry with pipe cleaner and place one drop of CLP. Refer to Figure 3-66.

CAUTION

DO NOT USE Q-TIPS TO CLEAN CARRIER KEY.

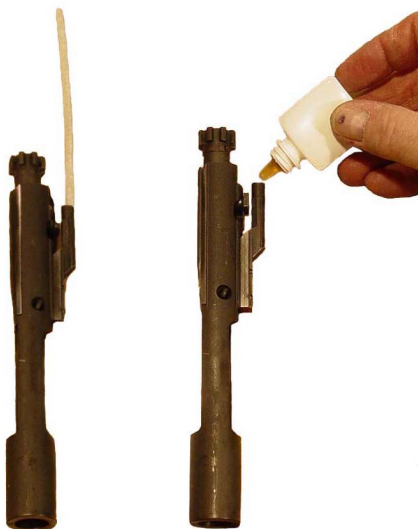

Figure 3-66. Apply CLP to Carrier Key

- (2) Generously lubricate the outside of the firing pin retaining pin, cam pin and bolt. Pay special attention to cam pin area, bolt rings and outside

of the bolt body. Apply a light coat to extractor and pin. Refer to Figure 3-67.

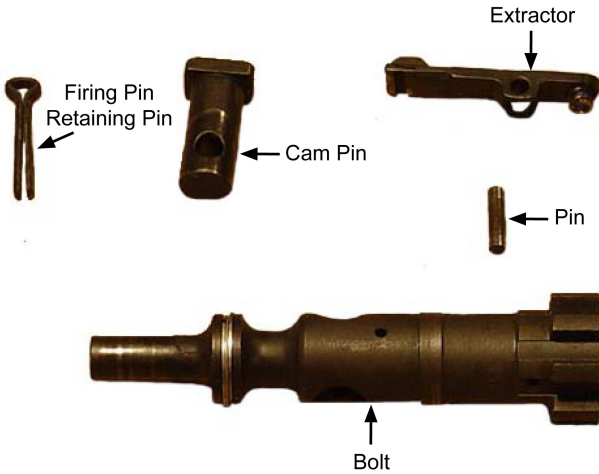

Figure 3-67. Lubricate Bolt Carrier Group

- (3) Lightly lubricate the charging handle and the inner and outer surfaces of bolt carrier. Generously lubricate slide and cam pin area of bolt carrier. Refer to Figure 3-68.



Figure 3-68. Lubricate Slide and Bolt Carrier

d. Lower Receiver Group.

- (1) Lightly lubricate inside lower receiver extension.
- (2) Generously lubricate takedown, pivot pins and detents.

- (3) Lightly lubricate all moving parts inside lower receiver and pins. Refer to Figure 3-69.



Figure 3-69. Lubricate Lower Receiver Extension Parts

- e. Adjustable Rear Sight.

NOTE

NOTE LOCATION OF THE SIGHTS BEFORE CLEANING. THIS ENSURES THE SIGHTS ARE RETURNED TO THE ORIGINAL POSITION AT COMPLETION OF THE TASK.

- (1) Moving Parts. Apply one drop of CLP to the moving parts listed below. Rotate parts to ensure lubricant is spread evenly. Refer to Figure 3-70.

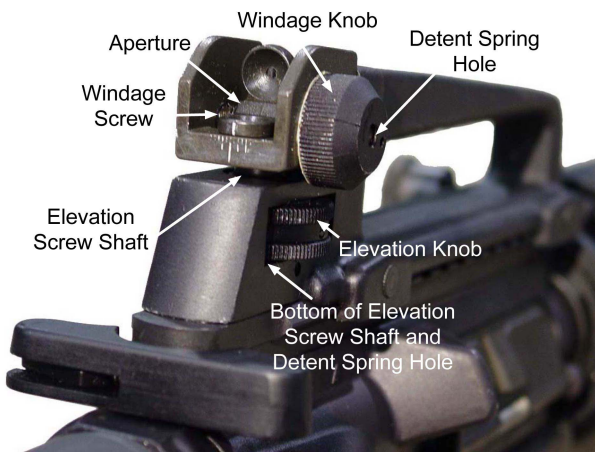

Figure 3-70. Lubricate Adjustable Rear Sight

- (a) Elevation knob
 - (b) Elevation screw shaft (top and bottom)
 - (c) Windage knob (maximum five clicks left or right)
 - (d) Windage screw
 - (e) Detent spring holes
 - (f) Aperture (flip up and down).
- (2) Elevation Screw Shaft. Lubricate from inside the upper receiver as follows:
- (a) Turn upper receiver upside down.
 - (b) Remove charging handle.
 - (c) Place two or three drops around the bottom edge of the elevation screw shaft and in elevation detent spring hole.
 - (d) Rotate the elevation dial as far as possible several times while keeping upper receiver upside down.

3-27. AFTER LUBRICATION OF REAR SIGHT.

- a. Reset correct zero windage and battle sight zero. Refer to paragraph 2-5.
- b. The rear sight comes down when the #3 is aligned with the mark on the left side of the receiver.
- c. A click will be felt when the #3 first lines up with the mark.

- d. Keep the sight on 300 meters to keep dirt and water out of the sight mechanism and to protect the sight from damage.

3-28. LUBRICATION AFTER AMPHIBIOUS OPERATIONS.

- a. If the rear sight is exposed to salt water, thoroughly clean as soon as the tactical situation allows.
- b. Thoroughly rinse the rear sight in fresh water until the tactical situation allows it to be cleaned with CLP.

3-29. PREVENTIVE MAINTENANCE CHECKS AND SERVICES.

- a. General. To ensure the readiness of the weapon, perform preventive maintenance procedures prior to each mission in accordance with Table 3-1. Preventive maintenance procedures include inspection, cleaning and performance of the checkout procedures.
- b. Explanation of PMCS Table Columns and Entries.
 - (1) Item Number. Numbers in this column act as references. When completing an Equipment Inspection and Maintenance Worksheet, include the item number for the check / service item. Item numbers appear in the order in which checks and services are to be completed.
 - (2) Interval. This column lists when the procedures stated in the procedure column must be done. BEFORE procedures must be done prior to operating the equipment for its intended mission. DURING procedures must be done while operating the equipment for its intended mission.

AFTER procedures must be done immediately following the operation of the equipment.

- (3) Location, Item to Check / Service. This column provides the location to be checked or serviced. The item location is underlined.
 - (4) Procedure. This column states the procedure to check or service the item listed in the Check / Service column to ensure the equipment is ready for the intended mission. The procedure must follow the time stated in the interval column.
 - (5) Not Fully Mission Capable If: This column states what faults will keep the weapon from being capable of performing the primary mission. If the check and service procedures result in finding faults listed in this column, do not operate the equipment. Follow standard operating procedures for maintaining the equipment or reporting equipment failure.
- c. Other Table Entries. Observe all special information and notes appearing in the table.

WARNINGS

CONFIRM THE WEAPON IS UNLOADED AND ON SAFE BEFORE PERFORMING THE FOLLOWING PROCEDURES

DO NOT KEEP LIVE AMMUNITION NEAR THE WORK AREA.

Table 3-1. Preventive Maintenance Checks and Services (PMCS)

Item No.	Interval	Location	Procedure	Not Fully Mission Capable If:
		Item to Check / Service		
1.	Before	Visual Inspection of Weapon	Check the weapon for missing or damaged parts. Report missing or damaged parts to armorer.	Parts are missing or damaged to the point of being unserviceable.
2.	During	Periodic Inspection of Weapon	Periodically check weapon to make sure it is clean and there is no foreign material in bore. If foreign material is in bore, clean bore (paragraph 3-16).	Foreign material is in bore.
3.	Before & After	Magazine	Magazine slips easily into the magazine well and locks in place.	Magazine is distorted or is hard to seat in magazine well.
			Magazine follower has sprung tension and moves easily inside of magazine.	Magazine follower is stuck or has weak spring tension.
4.	Before & After	Upper Receiver - Barrel	Check for barrel looseness (using hand pressure only).	Barrel is loose enough to be moved by hand.
5.		Upper Receiver - Carrying Handle Assembly	Check for missing or damaged parts and ensure the handle assembly will mount to the upper receiver.	Handle assembly is missing, has damaged parts or will not mount to upper receiver.

Table 3-1. Preventive Maintenance Checks and Services (PMCS) (Continued)

Item No.	Interval	Location	Procedure	Not Fully Mission Capable If:
		Item to Check / Service		
6.	Before & After	Upper Receiver-Handguards	Check for tightness of retaining clip. Check for cracks or missing parts.	Retaining clip fails to serve handguards.
7.	Before & After	Upper Receiver-Compensator	Check for looseness.	Compensator is loose.
8.	Before & After	Lower Receiver-Magazine Catch	Check magazine catch for spring tension and retention of magazine. (Note: perform this check with the weapon assembled.)	Magazine catch has no spring tension or does not retain or release magazine.
	Before	Magazine Catch (Function)	Insert magazine into well. The magazine catch should hold the magazine in place. Pressing the magazine catch button should release the magazine. To adjust the magazine catch, use the cleaning rod to press in on the magazine catch button until the left side of the magazine catch sticks out beyond the receiver. To tighten, turn the magazine catch clockwise; to loosen, turn it counterclockwise.	The magazine catch will not retain or release the magazine.

Table 3-1. Preventive Maintenance Checks and Services (PMCS) (Continued)

Item No.	Interval	Location	Procedure	Not Fully Mission Capable If:
		Item to Check / Service		
9.	Before & After	Lower Receiver-Buttstock	Check for cracks, looseness and missing parts.	Buttstock is loose.
10.	Before & After	Weapon Sights (Zero Adjustment)	Move front and rear sights to make sure they can be adjusted. Return sights to zero setting on weapon.	The sights are damaged, missing or cannot be adjusted.
11.	Before & After	Maintenance Performed During Firing Operations	Clean and lubricate weapon (paragraph 3-16) after firing approximately 200 rounds of ammunition or at the end of the day.	
12.	After	Maintenance of Weapon and Equipment	Disassemble weapon (paragraph 3-12). Clean and lubricate according to paragraph 3-16. Disassemble magazine (paragraph 3-14). Clean and lubricate bayonet and scabbard. Report all damaged or missing parts to unit armorer.	

Table 3-1. Preventive Maintenance Checks and Services (PMCS) (Continued)

Item No.	Interval	Location	Procedure	Not Fully Mission Capable If:
		Item to Check / Service		
13a.	Functional Check	Safety Selector Level: SAFE	Place selector lever on SAFE. Pull charging handle to rear and release *slowly. Slowly release the trigger without stops or hesitations. Pull trigger. Hammer should not fall. *NOTE Slow is defined as 1/4 to 1/2 the normal rate of trigger release.	Hammer falls.
13b.		Selector Lever: SEMI	Place selector lever on SEMI. Pull trigger and hold to rear. Hammer should fall. Pull charging handle to rear and release. Release trigger and pull again. Hammer should fall.	Hammer does not fall.
13c.		Selector Lever: BURST	Place selector lever on BURST (M16A2 and M4 only). Pull charging handle to rear and release. Release trigger. Pull trigger again. Hammer should fall.	Hammer does not fall.

Table 3-1. Preventive Maintenance Checks and Services (PMCS) (Continued)

Item No.	Interval	Location	Procedure	Not Fully Mission Capable If:
		Item to Check / Service		
13d.		Selector Lever: AUTO	AUTO (CQBW only): Pull the charging handle to the rear, cocking the weapon. Squeeze the trigger; hammer should fall. Hold the trigger to the rear and cock the weapon again. Fully release the trigger and squeeze it again. The hammer should not fall because it should have fallen when the bolt was allowed to move forward during the chambering and locking sequences.	Hammer does not fall.

CHAPTER 4 TROUBLESHOOTING

4-1. MALFUNCTIONS.

Table 4-1 lists common malfunctions that may occur with the equipment. Perform the tests, inspections and corrective actions in the order shown in the table. The table cannot list all the malfunctions, tests and inspections needed to determine the problem, or all of the corrective actions needed to correct the problem. If the weapon malfunction is not listed or actions listed do not correct the fault, notify unit armorer.

Table 4-1. Troubleshooting

PROBLEM	CHECK FOR	WHAT TO DO
Won't fire	<ul style="list-style-type: none"> a. Selector lever on SAFE. b. Magazine seated properly. c. Check magazine for damage. d. Light indentation on the primer e. Improper assembly of firing pin. f. Too much oil in firing pin recess. g. Defective ammunition. h. Excessive carbon on firing pin or in firing pin recess. 	<ul style="list-style-type: none"> a. Place selector lever on SEMI or BURST. b. Reseat magazine. c. Replace magazine. d. Notify unit armorer. e. Assemble firing pin correctly. Retaining pin goes in back of large shoulder of firing pin. f. Clean firing pin recess with pipe cleaner. g. Remove and discard ammunition. h. Clean firing pin and / or firing pin recess.
Won't fire BURST	<ul style="list-style-type: none"> a. Check magazine for ammunition. b. Selector lever on BURST. 	<ul style="list-style-type: none"> a. Load ammunition. b. Place selector lever on BURST.
Bolt won't unlock	<ul style="list-style-type: none"> a. Dirty or burred bolt. 	<ul style="list-style-type: none"> a. Contact the NCO or unit armorer.
Won't extract	<ul style="list-style-type: none"> a. Dirty or corroded ammunition. b. Broken extractor spring. c. Carbon in chamber. 	<ul style="list-style-type: none"> a. Remove magazine. Push out jammed cartridge with cleaning rod. b. Contact unit armorer. c. Clean chamber.

Table 4-1. Troubleshooting (Continued)

PROBLEM	CHECK FOR	WHAT TO DO
Won't extract (cont'd)	<p>d. Restricted movement of bolt carrier group.</p> <p>e. Fouling or carbon in extractor recess or lip.</p> <p>f. Frozen extractor.</p> <p>g. Restricted buffer assembly.</p>	<p>d. Remove, clean and lube bolt carrier group. (Before replacing bolt, check gas tube fits into carrier key and the carrier moves freely.)</p> <p>e. Clean extractor.</p> <p>f. Remove and clean extractor.</p> <p>g. Remove and clean buffer assembly.</p>
Won't feed	<p>a. Magazine not fully seated.</p> <p>b. Dirty or corroded ammunition.</p> <p>c. Dirty magazine.</p> <p>d. Defective magazine.</p> <p>e. Too many rounds in magazine.</p> <p>f. Action of buffer assembly is restricted.</p>	<p>a. Fully seat magazine.</p> <p>b. Clean or replace ammunition.</p> <p>c. Clean magazine.</p> <p>d. Replace magazine.</p> <p>e. Remove excess cartridges.</p> <p>f. Remove buffer and spring and clean.</p>
Double feed	<p>a. Defective magazine.</p>	<p>a. Replace magazine.</p>
Won't chamber	<p>a. Dirty or corroded ammunition.</p> <p>b. Damaged ammunition.</p> <p>c. Carbon in chamber or on gas tube.</p>	<p>a. Clean or replace ammunition.</p> <p>b. Replace ammunition.</p> <p>c. Clean chamber.</p>
Won't lock	<p>a. Dirt, corrosion or carbon build-up in barrel locking lugs.</p>	<p>a. Clean lugs.</p>

Table 4-1. Troubleshooting (Continued)

PROBLEM	CHECK FOR	WHAT TO DO
Short recoil	a. Gaps in bolt rings (not staggered). b. Carbon or dirt in carrier key or on outside of gas tube. c. Q-tip, pipe cleaner stuck inside carrier key.	a. Stagger ring gaps. b. Clean carrier and gas tube. c. Return weapon to armorer.
Bolt fails to lock after last round	a. Dirty or corroded bolt latch.	a. Clean bolt latch.
Bolt carrier "hung up"	a. Round jammed between bolt and charging handle and / or double feed.	a. Remove magazine. Push in on the bottom of the bolt latch. <div style="text-align: center;">WARNING</div> <p>KEEP CLEAR OF MUZZLE.</p> <div style="text-align: center;">CAUTION</div> <p>AFTER ROUND IS REMOVED, BOLT IS UNDER TENSION.</p> <p>While bolt is held to rear, round should fall through magazine well.</p> <div style="text-align: center;">NOTE</div> <p>IF THE PROCEDURE FAILS, USE A CLEANING ROD TO PUSH BOLT FULLY TO REAR THROUGH EJECTION PORT.</p>

Table 4-1. Troubleshooting (Continued)

PROBLEM	CHECK FOR	WHAT TO DO
Selector lever binds	a. Needs lubrication. b. Dirt or sand under trigger.	a. Lubricate with CLP. b. Clean trigger.
Handguard retaining clip fails to serve handguards	a. Check for tightness of retaining clip. b. Check for cracks or missing parts.	a. Replace handguards. b. Replace handguards.

**APPENDIX A
REFERENCE PUBLICATIONS**

A-1. SCOPE.

This appendix lists all forms, field manuals, technical manuals, tables, regulations, standards and miscellaneous publications referenced in this manual.

A-2. MARINE CORPS ORDERS.

MCO 4855.10 Product Quality Deficiency Report (PQDR)

A-3. TECHNICAL MANUALS.

TM 4700-15/1	Ground Equipment Record Procedures
TM 10470A-12&P/1	Target Pointer Illuminator / Aiming Light
TM 10471A-12&P/1	Operator's Manual for the Laser Boresight System
TM 07700A-23&P/2	M203 Grenade Launcher Organizational and Intermediate Maintenance Manual
TM 9150-15/1	Military Use of Cleaner, Lubricant, Preservative (CLP) for Weapons and Support Equipment

A-4. FORMS.

NAVMC 10772 Recommended Changes to Technical Publications

A-5. MILITARY STANDARDS.

MIL-STD-1913 Dimensioning of Accessory Mounting Rail for Small Arms Weapon

APPENDIX B LIST OF COMPONENTS

B-1. SCOPE.

This publication lists all components and accessories for collection-type supply items, such as major combinations, systems, groups, outfits sets or assortments. The components to be issued with the end item are identified under the heading of SUPPLY SYSTEM RESPONSIBILITY and when required, under the heading COLLATERAL MATERIEL. End items requiring collateral materiel are governed by whether the end item is initial issue or replacement issue. The Marine Corps Logistics Base, Albany, GA will direct whether the initial issue of the end item is with a collateral material set or replacement issue without collateral materiel. The components to be issued will consist of the quantity of items annotated in the QUANTITY USED IN UNIT column. The USING UNIT RESPONSIBILITY heading will reflect those items that are to be requisitioned separately through the supply system when applicable.

B-2. EXPLANATION OF COLUMNS.

This listing comprises the major portion of this publication. The data, arranged in columnar form, presents the information needed to identify the item and determine its type of issue.

- a. Item Number (Column 1). This column specifies a number assignment for each item as it appears in the list. Numbers are assigned in sequence and are for reference purposes only.
- b. Stock Number (Column 2). This column furnishes the National Stock Number (NSN) assigned to the item.
- c. Reference Designator / Figure-Key (Column 3). This column indicates circuit-symbol number designators or figure and index numbers to refer an item to a circuit diagram or illustration.

- d. Item Identification / Model (Column 4). This column provides the item name, description and model listed under the heading of either SUPPLY SYSTEM RESPONSIBILITY, COLLATERAL MATERIEL or USING UNIT RESPONSIBILITY. (If weapon model is not identified item applies to all weapons).
- e. Unit of Measure (Column 5). This column gives the measurement standard of each item. It may or may not be the same as the unit of issue. For example, the unit of issue of a certain wire is coil but only 4 feet are required for the end item. Therefore, the unit of measure shown will not be used for requisitioning purposes. For the proper unit of issue and other required management data, refer to the applicable Management Data List (ML) when requisitioning.
- f. Quantity Used in Unit (Column 6). This column lists the total quantity of an item according to the unit of measure, required for full functional operation of the end item.

B-3. SUPPLY SUPPORT CATEGORIES.

- a. Supply System Responsibility. All or a portion of the items in this category, as appropriate for the type of issue, will be furnished by the supply system. Any item requiring replacement, while the end item is outside the stores distribution system is the responsibility of the holding organization or using unit.
- b. Collateral Material. All of the items in this category will be furnished with the end item when the end item is being shipped as initial issue. The 9999-00-000-000 NSN shown under the heading of COLLATERAL MATERIEL is for control within the distribution system only, and is not authorized for requisitioning purposes.
- c. Using Unit Responsibility. Items in this category will not be issued with the end item. They must be requisitioned through the supply system. The end item will be complete only when the total quantity of items

shown in the QUANTITY USED IN UNIT column as well as those items listed under the heading SUPPLY SYSTEM RESPONSIBILITY and COLLATERAL MATERIEL are on hand.

B-4. 5TH ECHELON REHABILITATION PROGRAM.

Major items returned under this program will be evacuated under the provision(s) of the applicable Marine Corps Order(s) with the items listed under Supply System Responsibility. Repair, rebuild and replacement under a 5th Echelon rehabilitation program will be limited to these items only. Those items under the heading COLLATERAL MATERIEL shall be held by using organizations for application to the replacement end items.

B-5. REQUEST FOR ADDITIONAL COPIES.

Additional copies of this publication may be requisitioned through the MCPDS on line requisition.

B-6. SPECIAL NOTES

- a. Rifle, 5.56mm, M16A2. This weapon will be reported on Unit Property Control Records under NSN 1005-01-128-9936. Rifle, 5.56mm, M16A2, includes 1 each magazine, NSN 1005-00-921-5004.
- b. Rifle, 5.56mm, M16A4. This weapon will be reported on Unit Property Control Records under NSN 1005-01-357-2872. Rifle, M16A4 includes 1 each magazine, NSN 1005-00-921-5004.
- c. Carbine, 5.56mm, M4. This weapon will be reported on Unit Property Control Records under NSN 1005-01-231-0973. Carbine, 5.56mm, M4 includes 1 each magazine, NSN 1005-00-921-5004.

TM 05538/10012-10A/1

- d. Carbine, 5.56mm, M4A1. This weapon will be reported on Unit Property Control Records under NSN 1005-01-3821-0953. Carbine, 5.56mm, M4 includes 1 each magazine, NSN 1005-00-921-5004.

- e. Maintenance Forms and Records. Marine Corps users maintain forms and records as prescribed by TM 4700-15/1. Department of the Army forms and records will be those prescribed by DA PAM 738-750.

LIST OF COMPONENTS

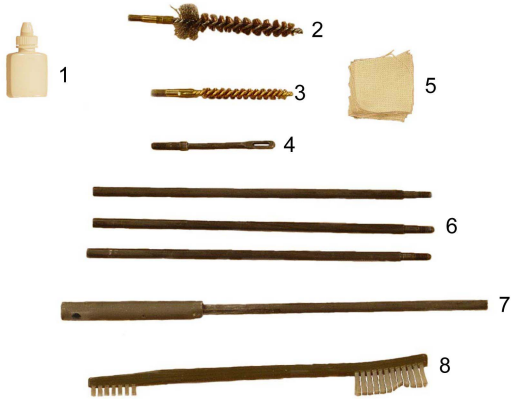

Figure B-1. Standard Cleaning Kit

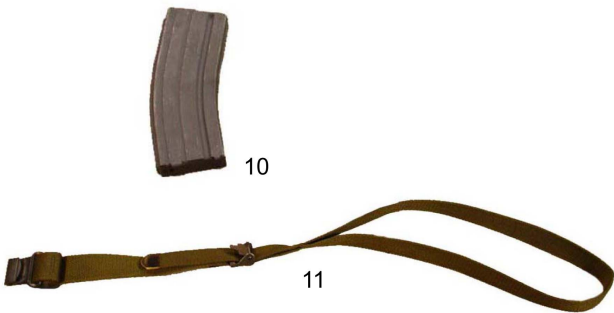

Figure B-2. Magazine and Sling

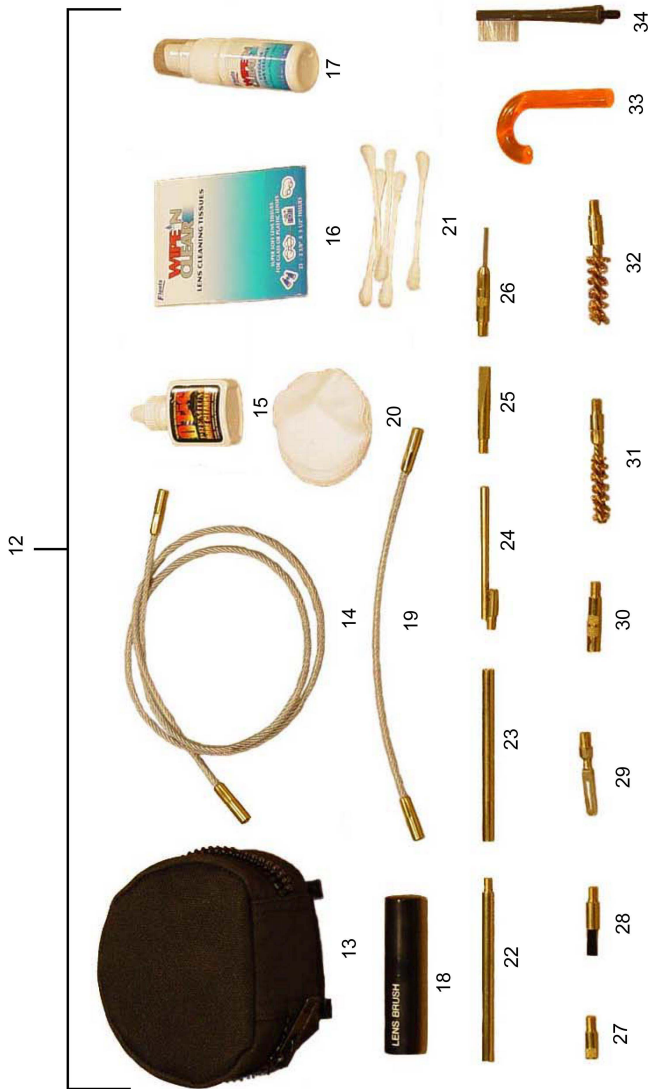
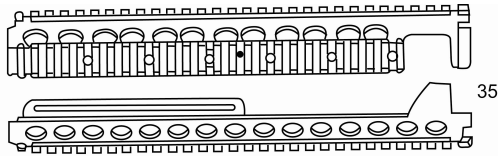
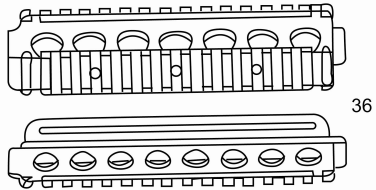

Figure B-3. Otis Cleaning Kit

RAIL COVER
11 RIB
M16A4



ADAPTER RAIL
M4A1 CQBW



HANDGUARD SECTION
11-RIB
M16A4 (4)
M4A1 CQBW (4)

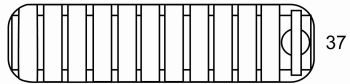

HANDGUARD SECTION
9-RIB
M16A4 (2)



HANDGUARD SECTION
6-RIB
M16A4 (1)
M4A1 CQBW (2)

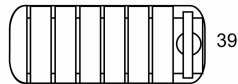

HANDGUARD SECTION
5-RIB
M16A4 (2)

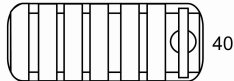

HANDGUARD SECTION
4-RIB
M16A4 (1)
M4A1 CQBW (1)

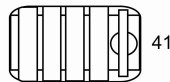

HANDGUARD SECTION
2-RIB
M4A1 CQBW (2)

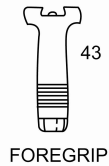
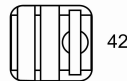

Figure B-4. Handguard Sections

Table B-1. List of Components

1 ITEM NO.	2 STOCK NUMBER	3 REF DES FIG KEY	4 ITEM IDENTIFICATION	5 UNIT OF MEAS	6 QTY USED IN UNIT
COLLATERAL MATERIEL					
1	9150-01-102-1473	B-1	CLEANER, LUBRICANT AND PRESERVATIVE, BREAK-FREE CLP: 2/3 oz, CAGE 65983	EA	1
2	1005-00-999-1435	B-1	BRUSH, CLEANING, SMALL ARMS: PN 8432358 / CAGE 19204	EA	1
3	1005-00-903-1296	B-1	BRUSH, CLEANING, SMALL ARMS: PN 11686340 / CAGE 19204	EA	1
4	1005-00-937-2250	B-1	SWAB HOLDER SECTION, SMALL ARMS CLEANING ROD: PN 11686327 / CAGE 19204	BT	1
5	1005-01-449-9257	B-1	PATCHES, CLEANING, SMALL CAL.: PN 921 / CAGE 01VS3	EA	
6	1005-00-050-6357	B-1	ROD SECTION CLEANING, SMALL ARMS: PN 8436775 / CAGE 19204	EA	3
7	1005-01-113-0321	B-1	ROD SECTION, CLEANING, SMALL ARMS: PN 8436776 / CAGE 19204	EA	1
8	1005-00-494-6602	B-1	BRUSH, CLEANING, SMALL ARMS: ON 8448462 / CAGE 19204	EA	

Table B-1. List of Components (Continued)

1 ITEM NO.	2 STOCK NUMBER	3 REF DES FIG KEY	4 ITEM IDENTIFICATION	5 UNIT OF MEAS	6 QTY USED IN UNIT
9	1005-00-403-5804		CASE, SMALL ARMS, CLEANING ROD: PN 8448751 / CAGE 19204	EA	1
10	1005-00-921-5004	B-2	MAGAZINE CARTRIDGE: 30 round; PN 8448670 / CAGE 19200	EA	6
11	1005-01-083-8113	B-2	SMALL ARMS SLING: PN 11833432 / CAGE 19200	EA	1
12	1005-01-448-8513	B-3	CLEANING KIT, GUN (Soft Belt-Pak): PN 223 / CAGE 01VS3 (M16, M4 and M4A1 CQBW only)	EA	1
KIT CONSISTS OF:					
13	1005-01-449-9683	B-3	CASE, SMALL ARMS,; PN 911-7 / CAGE 01VS3	EA	1
14	1005-01-449-8934	B-3	ROD, FLEXIBLE CLEANING: PN C-30-5 / CAGE 01VS3	EA	1
15	9510-01-102-1473	B-3	CLEANER, LUBRICANT AND PRESERVATIVE: PN 900 / CAGE 65983	EA	1
16	6640-00-663-0832	B-3	LENS CLEANING CLOTHS: PN 240-4	EA	1
17		B-3	LENS CLEANING SOLUTION	EA	1
18	1005-01-445-6798	B-3	BRUSH SET, CLEANING, SMALL ARMS: PN 3762 / CAGE 01VS3	EA	1

Table B-1. List of Components (Continued)

1 ITEM NO.	2 STOCK NUMBER	3 REF DES FIG KEY	4 ITEM IDENTIFICATION	5 UNIT OF MEAS	6 QTY USED IN UNIT
19	1005-01-452-8675	B-3	ROD, CLEANING, SMALL ARMS: PN C-8-7 / CAGE 01VS3	EA	1
20	1005-01-449-9257	B-3	PATCH, SMALL CAL.: PN 921 / CAGE 01VS3	EA	10
21	1005-01-912-4248	B-3	Q-TIPS, PN 240-5	EA	6
22	1005-01-449-9277	B-3	ADAPTER, ROD HANDLE: PN 9100 / CAGE 01SV3	EA	1
23	1005-01-445-5889	B-3	HANDLE, CLEANING ROD: PN 9098 CAGE 01VS3	EA	1
24	1005-01-449-8902	B-3	HANDLE, TEE: PN 01-5 CAGE 01VS3	EA	1
25	1010-01-445-6797	B-3	BRASS SCRAPER: PN 206K / CAGE 01VS3	EA	1
26	1005-01-449-9943	B-3	PICK: PN 100-39-5 / CAGE 01VS3	EA	1
27	1005-01-449-9674	B-3	ADAPTER, NATO: PN 316-5 / CAGE 01VS3	EA	1
28	1005-01-449-8928	B-3	BRUSH, END: PN 318-5 / CAGE 01VS3	EA	1
29	1005-01-449-9315	B-3	TIP, SLOTTED: PN 202-5 / CAGE 01VS3	EA	1
30	1005-01-449-9672	B-3	REMOVER, OBSTRUCTION: PN 104-5 / CAGE 01VS3	EA	1
31	1005-01-449-9159	B-3	BRUSH, CLEANING, SMALL ARMS: PN 335 / CAGE 01VS3	EA	1

Table B-1. List of Components (Continued)

1 ITEM NO	2 STOCK NUMBER	3 REF DES FIG KEY	4 ITEM IDENTIFICATION	5 UNIT OF MEAS	6 QTY USED IN UNIT
32	1005-01-449-8980	B-3	BRUSH, CLEANING, SMALL ARMS: PN 325 / CAGE 01VS3	EA	1
33	NSN PENDING	B-3	BORE LITE, RED FIBER OPTIC	EA	1
34	1005-01-445-6799	B-3	BRUSH SET, CLEANING, SMALL ARMS: PN 324K / CAGE 01VS3	EA	1
END OF CLEANING KIT					
35	1005-01-453-5386	B-4	RAIL COVER, 11 RIB (RAS) M16A4, PN 1273132 / CAGE 19200	EA	1
36	1005-01-452-3527	B-4	ADAPTER RAIL, WEAPON: PN 12973095 / CAGE 19200 (M4A1 CQBW)	EA	1
37	1005-01-453-5386	B-4	RAIL COVER, 11 RIB: PN 12973132 / CAGE 19200 M16A4 M4A1 CQBW	EA EA	4 4
38	1005-01-453-5383	B-4	RAIL COVER, 9 RIB PN 12973134 / CAGE 19200 M16A4	EA	2
39	1005-01-453-4222	B-4	RAIL COVER, 6 RIB: PN 12973135 / CAGE 19200 M16A4 M4A1 CQBW	EA EA	1 2

Table B-1. List of Components (Continued)

1 ITEM NO	2 STOCK NUMBER	3 REF DES FIG KEY	4 ITEM IDENTIFICATION	5 UNIT OF MEAS	6 QTY USED IN UNIT
40	1005-01-453-4221	B-4	RAIL COVER, 5 RIB: PN 12973136 / CAGE 19200 M16A4	EA	2
41	1005-01-453-4223	B-4	RAIL COVER, 4 RIB: PN 12973137 / CAGE 19200 M16A4 M4A1 CQBW	EA EA	1 1
42	1005-01-453-4228	B-4	RAIL COVER, 2 RIB: PN 12973138 / CAGE 19200 M4A1 CQBW	EA	2
43	1005-01-453-6655	B-4	GRIP, RIFLE: PN 12973101 / CAGE 19200 M16A4 M4A1 CQBW	EA EA	1 1
USING UNIT RESPONSIBILITY					
44	1005-00-193-8306		BAG, PROTECTIVE MAGAZINE: PN 8448464 / CAGE 19204		A/R
45	1005-00-118-6192		FIRING ATTACHMENT BLANK AMMUNITION: PN 12002900 / CAGE 19204 (M16 ONLY)	EA	A/R
46	1005-00-242-5687		BOTTLE ASSEMBLY, CYL: PN 8448444 / CAGE 19204 (1 OZ BOTTLE FOR LAW)	AY	A/R

Table B-1. List of Components (Continued)

1 ITEM NO.	2 STOCK NUMBER	3 REF DES FIG KEY	4 ITEM IDENTIFICATION	5 UNIT OF MEAS	6 QTY USED IN UNIT
47	5340-00-880-7666		CAP, PROTECTIVE, DUST AND MOISTURE SEAL: PN 8445067 / CAGE 19204	HD	A/R
48	1005-00-809-2190		COVER, PROTECTIVE, RIGHT: PN 8448213 / CAGE 19204	BX	A/R
49	1005-00-406-1570		KIT, ADAPTER, TOP SLING: PN 8448471 / CAGE 19204	EA	A/R
50	1005-00-233-9031		LOCKING, PLATE NUT AND BOLT: PN 8448676 / CAGE 19204	EA	A/R
51	1095-00-223-7164		SCABBARD, BAYONET-KNIFE M8A1 or M10: PN 8448476 / CAGE 19204	EA	1
52	1005-01-216-4510		SLING, SMALL ARMS (M16A2): PN 12624561 / CAGE 19204	EA	1
53	1005-01-368-9852		SLING, SMALL ARMS (M4A1 CQBW Carbine): PN 12011996 / CAGE 19200	EA	1

Table B-1. List of Components (Continued)

1 ITEM NO.	2 STOCK NUMBER	3 REF DES FIG KEY	4 ITEM IDENTIFICATION	5 UNIT OF MEAS	6 QTY USED IN UNIT
54	1005-01-361-8208		FIRING ATTACHMENT, BLANK AMMUNITION: PN 12597837 / CAGE 19200 M23 (M4 / M4A1 CQBW Carbine) Yellow (Training Only)	EA	A/R
55	8465-00-781-9564		CASE, MAINTENANCE EQUIPMENT SMALL ARMS: (CARBINE ONLY)	EA	A/R
56	9150-00-935-6597		LUBRICATING OIL, SEMI-FLUID: PN MILL46000 / CAGE 81349 (2 OZ)	BT	A/R
57	9150-00-889-3522		LUBRICATING OIL, SEMI-FLUID: PN 8436793 / CAGE 19204 (4 OZ)	EA	A/R
58	1005-01-473-0324		SUPPRESSOR	EA	1
59	5855-01-448-5464		ILLUMINATOR, INFRARED: PN VLI- 002 / CAGE 0B107	EA	1
EXPENDABLES					
60	7920-00-205-1711		RAG, WIPING: PN A-A-531 / CAGE 58536 (GSA – 50 LB)	BE	A/R
61	9150-00-292-9689		LUBRICATING OIL, WEAPONS (LAW): PN MIL-L-14107 (1 quart can) / CAGE 81349	QT	A/R

Table B-2. Inventory Sheet

Inventory Sheet														
Name of Equipment: M16A4 and M4A1 CQBW Equipment														
Item No	Stock Number	Item ID	Unit of Measure											
			Qty Used in Unit											
			Month											
			J	F	M	A	M	J	J	A	S	O	N	D
1	9510-01-102-1473	Cleaner, Lubricant and Preservative, Break-free CLP, 2/3 oz	ea	1										
2	1005-00-999-1435	Brush, Cleaning, Small Arms	ea	1										
3	1005-00-903-1296	Brush, Cleaning, Small Arms	ea	1										
4	1005-00-937-2250	Swab Holder Section, Small Arms Cleaning Rod	ea	3										
5	1005-01-449-9257	Patches, Cleaning	ea	1										
6	1005-00-050-6357	Rod Section Cleaning, Small Arms	ea	3										
7	1005-01-113-0321	Rod Section Cleaning, Small Arms	ea	1										

Table B-2. Inventory Sheet (Continued)

Inventory Sheet															
Name of Equipment: M16A4 and M4A1 Equipment															
Item No	Stock Number	Item ID	Unit of Measure	Qty Used in Unit											
				Month											
				J	F	M	A	M	J	J	A	S	O	N	D
8	1005-00-494-6602	Brush, Cleaning, Small Arms	ea												
9	1005-00-403-5804	Case, Small Arms, Cleaning Rod	ea	1											
10	1005-00-921-5004	Magazine Cartridge	ea	6											
11	1005-01-083-8113	Small Arms Sling	ea	1											
12	1005-01-448-8513	Cleaning Kit, Gun (M16 / M4 / M4A1 CQBW Only)	ea	1											
13	1005-01-449-9683	Case, Small Arms, Cleaning Rod	ea	1											
14	1005-01-449-8934	Rod, Flexible Cleaning	ea	1											
15	9510-01-102-1473	Cleaner, Lubricant And Preservative	ea	1											

Table B-2. Inventory Sheet (Continued)

Inventory Sheet															
Name of Equipment: M16A4 and M4A1 Equipment															
Item No	Stock Number	Item ID	Unit of Measure	Qty Used in Unit											
				Month											
				J	F	M	A	M	J	J	A	S	O	N	D
16	6640-00-663-0832	Lens Cleaning Solution and Cloths	ea 1												
17		Lens Cleaning Solution	ea 1												
18	1005-01-445-6798	Brush Set, Cleaning, Small Arms	ea 1												
19	1005-01-452-8675	Rod, Cleaning, Small Arms	ea 1												
21	1005-01-912-4248	Q-Tips	ea 6												
22	1005-01-449-9277	Adapter, Rod Handle	ea 1												
23	1005-01-445-5889	Handle, Cleaning Rod	ea 1												
24	1005-01-449-8902	Handle, Tee	ea 1												
25	1010-01-445-6797	Brass Scraper	ea 1												
26	1005-01-449-9943	Pick	ea 1												
27	1005-01-449-9674	Adapter, NATO	ea 1												
28	1005-01-449-8928	Brush, End	ea 1												

Table B-2. Inventory Sheet (Continued)

Inventory Sheet														
Name Of Equipment: M16A4 AND M4A1 Equipment														
Item No	Stock Number	Item Id	Unit Of Measure											
			Qty Used In Unit											
			Month											
			J	F	M	A	M	J	J	A	S	O	N	D
29	1005-01-449-9315	Tip, Slotted	ea	1										
30	1005-01-449-9672	Remover, Obstruction	ea	1										
31	1005-01-449-9159	Brush, Cleaning, Small Arms	ea	1										
32	1005-01-449-8980	Brush, Cleaning, Small Arms	ea	1										
33	NSN Pending	Bore Lite, Red Fiber Optic	ea	1										
35	1005-01-453-5386	Rail Cover (RAS), 11 Rib (M16A4)	ea	1										
36	1005-01-452-3527	Adapter Rail, Weapon (M4A1)	ea	1										
37	1005-01-453-5386	Rail Cover, 11 Rib	ea											
		M16A4	ea											
		M4A1	ea											
		CQBW												

Table B-2. Inventory Sheet (Continued)

Inventory Sheet														
Name of Equipment: M16A4 And M4A1 Equipment														
Item No	Stock Number	Item Id	Unit of Measure											
			Qty Used In Unit											
			Month											
			J	F	M	A	M	J	J	A	S	O	N	D
38	1005-01-453-5383	Rail Cover, 9 Rib	ea	1										
39	1005-01-453-4222	Rail Cover, 6 Rib	ea	2										
40	1005-01-453-4221	Rail Cover, 5 Rib	ea	2										
41	1005-01-453-4223	Rail Cover, 4 Rib		1										
		M16A4	ea	1										
		M4A1	ea	1										
42	1005-01-453-4228	Rail Cover, 2 Rib												
		M4A1	ea	1										
43	1005-01-453-6655	Grip, Rifle	ea	1										
		M16A4	ea	1										
		M4A1	ea	1										
44	1005-00-193-8306	Bag, Protective, Magazine	ea	A/R										
45	1005-00-118-6192	Firing Attachment, Blank Ammunition	ea	1										

Table B-2. Inventory Sheet (Continued)

Inventory Sheet														
Name of Equipment: M16a4 And M4A1 Equipment														
Item No	Stock Number	Item Id	Unit of Measure											
			Qty Used in Unit											
			Month											
			J	F	M	A	M	J	J	A	S	O	N	D
46	1005-00-242-5687	Bottle Assembly, Cyl	ea	A/	R									
47	5340-00-880-7666	Cap, Protec-tive, Dust and Moisture Seal	ea	A/	R									
48	1005-00-809-2190	Cover, Protec-tive, Rifle	ea	A/	R									
49	1005-00-406-1570	Kit, Adapter, Top Sling	ea	A/	R									
50	1005-00-233-9031	Locking Plate, Nut and Bolt	ea	A/	R									
51	1095-00-223-7164	Scabbard, Bayonet-Knife (M8A1 or M10)	ea	A/	R									
52	1005-01-216-4510	Sling, Small Arms (M16A2)	ea	1										
53	1005-01-368-9852	Sling, Small Arms (M4A1 Carbine)	ea	1										

Table B-2. Inventory Sheet (Continued)

Inventory Sheet														
Name of Equipment: M16A4 and M4A1 Equipment														
Item No	Stock Number	Item Id	Unit of Measure											
			Qty Used in Unit											
			Month											
			J	F	M	A	M	J	J	A	S	O	N	D
54	1005-01-361-8208	Firing, Attachment, Blank Ammunition M23 (M4) Yellow	ea	A/										
55	8465-00-781-9564	Case, Maintenance Equipment, Small Arms	ea	A/										
58	1005-01-437-0324	Suppressor	ea	A/										

APPENDIX C AMMUNITION

C-1. USING TRACER AMMUNITION.

Use tracer ammunition to help hit the target during hours of darkness or low light levels. Tracer ammunition is not as effective as regular ball ammunition against most targets. Mix tracer ammunition with the ball ammunition in magazine when available. Refer to Figure C-1.

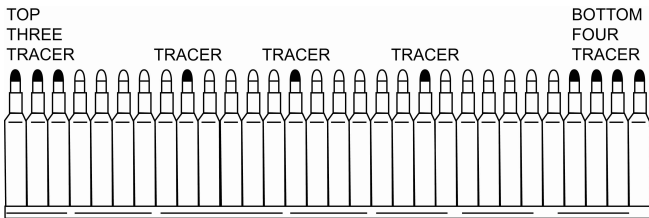

Figure C-1. Tracer Ammunition

NOTES

TRACER AMMUNITION IS RED TIPPED.

THE TOP THREE TRACERS HELP OPERATOR GET ON TARGET.

THE TRACERS BETWEEN BALL ROUNDS HELP OPERATOR STAY ON TARGET.

THE BOTTOM FOUR TRACERS ALERT OPERATOR WHEN TO CHANGE MAGAZINES.

C-2. CHANGING MAGAZINES.

In combat, insert a fully loaded magazine before the one being used is completely empty, if possible.

C-3. 5.56MM AMMUNITION.

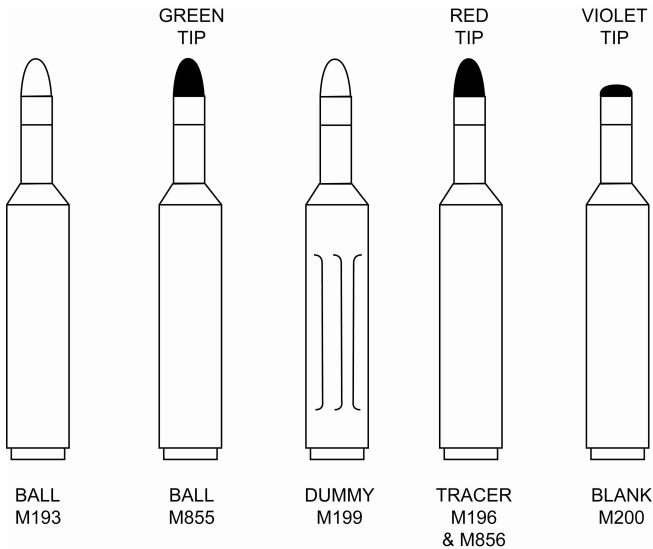

Figure C-2. Ammunition Examples

WARNING

DO NOT FIRE...

- **SERIOUSLY CORRODED AMMUNITION.**
- **DENTED CARTRIDGES.**
- **CARTRIDGES WITH LOOSE BULLETS.**
- **CARTRIDGES EXPOSED TO EXTREME HEAT (135°) UNTIL COOLED.**
- **CARTRIDGES WITH BULLET PUSHED IN (SHORT ROUNDS).**

WARNINGS

***TURN IN ANY DAMAGED OR
OVERHEATED CARTRIDGES TO
RANGE NCO.***

***USE ONLY AUTHORIZED
AMMUNITION MANUFACTURED TO
U.S. OR NATO SPECIFICATIONS.***

