

**TM 9-1005-309-23&P**

**TECHNICAL MANUAL**

**ORGANIZATIONAL AND DIRECT SUPPORT  
MAINTENANCE MANUAL  
(INCLUDING REPAIR PARTS AND SPECIAL TOOLS LIST)  
FOR  
SUBMACHINE GUN, 5.56-MM:  
PORT, FIRING, M231  
(1005-01-081-4582)**

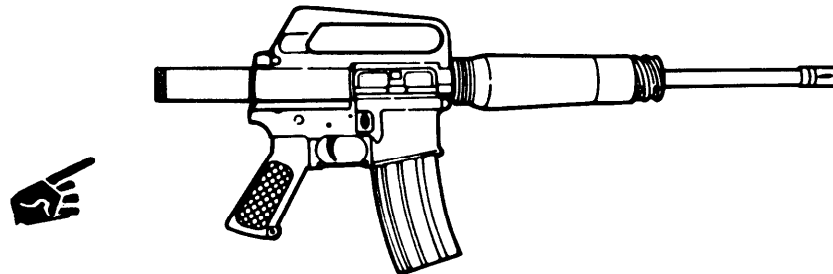

**HEADQUARTERS, DEPARTMENT OF THE ARMY  
MARCH 1983**

<b>RPSTL</b>
<b>PAGE C-1</b>

<b>MAC</b>
<b>PAGE B-1</b>

<b>MAINTENANCE PROCEDURES- DIRECT SUPPORT</b>
<b>PAGE 3-9</b>

<b>TROUBLE- SHOOTING DIRECT SUPPORT</b>
<b>PAGE 3-1</b>

<b>MAINTENANCE PROCEDURES- ORGANIZATIONAL</b>
<b>PAGE 2-12</b>

<b>TROUBLE- SHOOTING- ORGANIZATIONAL</b>
<b>PAGE 2-8</b>

<b>PMCS- ORGANIZATIONAL</b>
<b>PAGE 2-3</b>

**WARNING**

Before starting any procedures on the M231 submachine gun be sure to clear weapon. Live ammunition should not be near the work area.

Be careful when removing spring loaded parts. Carelessness could result in injury.

Bolt cam pin must be installed or weapon will blow up when first round is fired.

To avoid possible explosion, never exchange or switch bolt carrier and striker assembly from one weapon to another.

Dry cleaning solvent (SD) (A-A-711) is flammable and should not be used near an open flame or in a sinking area. Use only in well-ventilated areas. This solvent evaporates quickly and has a drying effect on the skin. Use of gloves (item 10.1, app D) is necessary to protect the skin. When used without gloves it may cause cracks in the skin and in some cases mild irritation or inflammation.

When using solid film lubricant, be sure the area is well-ventilated.

First Aid

For further information on first aid, see FM 21-11.

CHANGE  
NO. 3

HEADQUARTERS  
DEPARTMENT OF THE ARMY  
Washington, D. C., 15 MAY 1990

ORGANIZATIONAL AND DIRECT SUPPORT MAINTENANCE MANUAL  
(INCLUDING REPAIR PARTS AND SPECIAL TOOLS LIST)  
FOR  
SUBMACHINE GUN, 5.56-MM PORT, FIRING, M231  
(1005-01-081-4582)

TM 9-1005-309-23&P, dated March 1983, is changed as follows:

1. Remove old pages and insert new pages as indicated below.
2. New or changed material is indicated by a vertical bar adjacent to the material.
3. New or changed illustrations are indicated by a miniature pointing hand highlighting the change.

<u>Remove Pages</u>	<u>Insert Pages</u>
i and ii	i and ii
2-11 and 2-12	2-11 and 2-12
2-23 thru 2-26	2-23 thru 2-26
2-41 and 2-42	2-41 thru 2-43 (2-44 blank)
3-9 and 3-10	3-9 and 3-10
3-21 thru 3-24	3-21 thru 3-24
3-59 and 3-60	3-59 and 3-60
None	3-60.1 and 3-60.2
C-8-1 and Figure C-9	C-8-1 and Figure C-9
C-9-1 and Figure C-10	C-9-1 and Figure C-10
C-10-1 and Blank	C-10-1 and Blank
Bulk 1 and Figure C-11	Bulk 1 and Figure C-11
C-11-1 and Blank	C-11-1 and Blank
I-1 thru I-4	I-1 thru I-4
D-3 thru D-5 (D-6 blank)	D-3 thru D-5 (D-6 blank)
E-1 and E-2	E-1 and E-2
cover and warning page	cover and warning page

File this change sheet in the back of the publication for reference purposes.

By Order of the Secretary of the Army:

**CARL E. VUONO**  
*General, United States Army*  
*Chief of Staff*

**Official:**

WILLIAM J. MEEHAN II  
*Brigadier General United States Army*  
*The Adjutant General*

**DISTRIBUTION:**

To be distributed in accordance with DA Form 12-40, (BLOCKS 264, 265), Unit and Direct Support Maintenance requirements for TM 9-1005-309-23&P.

CHANGE

No. 2

HEADQUARTERS  
DEPARTMENT OF THE ARMY  
Washington, D.C., 12 January 1988

Organizational and Direct Support  
Maintenance Manual  
(Including Repair Parts and Special Tools List)

for

SUBMACHINE GUN, 5.56-MM: PORT, FIRING, M231  
(1005-01-081-4582)

TM 9-1005-309-23&P, dated March 1983, is changed as follows:

**NOTE**

Because of a new military standard for RPSTLS, appendix C uses a right-reading format with no change symbols. The rest of this manual will remain in a broadside format.

Remove old pages and insert new pages as indicated below.

Remove Pages

C-1 through Figure C-4  
C-1-1 and C-2  
C-3-1 and C-4

Insert Pages

C-1 through C-4  
C-1-1 and Figure C-2  
C-3-1 and Figure C-4

**By Order of the Secretary of the Army:**

**CARL E. VUONO**  
*General, United States Army*  
*Chief of Staff*

**Official:**

**R. L. DILWORTH**  
*Brigadier General, United States Army*  
*The Adjutant General*

**DISTRIBUTION:**

To be distributed in accordance with DA Form 12-40, Unit, Direct Support and General Support Maintenance requirements for Submachine Gun, 5.56-MM, Port Firing, M231.

**CHANGE**

No. 1

HEADQUARTERS  
DEPARTMENT OF THE **ARMY**  
Washington, D.C., 11 December 1986

Organizational and Direct Support  
Maintenance Manual  
(Including Repair Parts and Special Tools List)

for

SUBMACHINE GUN, 5.56-MM: PORT, FIRING, M231  
(1005-01-081-4582)

TM 9-1005-309-23&P, dated March 1983, is changed as follows:

**NOTE**

Because of a new military standard for RPSTLs, appendix C will be replaced in its entirety, using a right-reading format with no change symbols. The rest of this manual will remain in a broadside format.

1. Remove old pages and insert new pages as indicated below.
2. New or changed material is indicated by a vertical bar in the margin of the page.
3. New or changed illustrations are indicated by a miniature pointing hand highlighting the change.

Remove Pages	Insert Pages	Remove Pages	Insert Pages
i through iv v and 1-0 1-1 through 1-4 2-1 through 2-10 None 2-11 and 2-12 2-15 through 2-22 2-27 through 2-30 2-35 through 2-42	i through iv v and 1-0 1-1 through 1-4 2-1 through 2-10 2-10.1 and 2-10.2 2-11 and 2-12 2-15 through 2-22 2-27 through 2-30 2-35 through 2-42	3-1 through 3-8 None 3-9 through 3-10 3-13 through 3-20 3-23 through 3-26 3-29 and 3-30 3-33 through 3-42 3-45 through 3-60	3-1 through 3-8 3-8.1(3-8.2 blank) 3-9 through 3-10 3-13 through 3-20 3-23 through 3-26 3-29 and 3-30 3-33 through 3-42 3-45 through 3-60

Remove Pages

3-63 and 3-64  
A-1 (A-2 blank)  
B-3 through B-6  
Appendix C  
D-1 through D-4  
None

Insert Pages

3-63 and 3-64  
A-1 (A-2 blank)  
B-3 through B-6  
Appendix C  
D-1 through D-4  
D-5 (D-6 blank)

Remove Pages

E-1 through E-4  
Index 1 through  
Index 4  
Front cover and  
warning page

Insert Pages

E-1 Through E-4  
Index 1 through  
Index 4  
Front cover and  
warning page

File this change sheet in back of the publication for reference purposes.

**By Order of the Secretary of the Army:**

**JOHN A. WICKHAM, JR.**  
*General, United States Army*  
*Chief of Staff*

**Official:**

**R. L. DILWORTH**  
*Brigadier General, United States Army*  
*The Adjutant General*

**DISTRIBUTION:**

To be distributed in accordance with DA Form 12-40, Organizational and Direct and General Support Maintenance requirements for Submachine Gun, 5.56-MM, Port Firing, M231.

**Organizational and Direct Support Maintenance Manual**  
**(Including Repair Parts and Special Tools List)**

for

**SUBMACHINE GUN, 5.56-MM:**  
**PORT, FIRING, M231**  
**(1005-01-081-4582)**

Current as of August 25, 1986 for appendix C

**REPORTING ERRORS AND RECOMMENDING IMPROVEMENTS**

You can help improve this manual. If you find any mistakes or if you know of away to improve the procedures, please let us know. Mail your letter, DA Form 2028 (Recommended Changes to Publications and Blank Forms), or DA Form 2028-2 located in the back of this manual direct to: Commander, US Army Armament, Munitions and Chemical Command, ATTN: AMSMC-MAS, Rock Island, IL 61299-6000. A reply will be furnished to you.

	Page	Illus/ Figure
HOW TO USE THIS MANUAL .....	iv	
CHAPTER 1 INTRODUCTION		
Section I General Information .....	1-1	
Section II Repair Parts, Special Tools, TMDE, and Support Equipment .....	1-2	
Section III Equipment Description and Data .....	1-2	
Section IV Principles of Operation .....	1-3	

			Page	Illus/ Figure
CHAPTER	2	ORGANIZATIONAL MAINTENANCE INSTRUCTIONS		
Section	I	Service Upon Receipt . . . . .	2-1	
Section	II	<b>Preventive Maintenance Checks and Services (PMCS)</b> . . . . .	2-3	
Section	III	Troubleshooting . . . . .	2-8	
Section	IV	<b>Maintenance Procedures</b> . . . . .	2-12	
CHAPTER	3	DIRECT SUPPORT MAINTENANCE INSTRUCTIONS		
Section	I	<b>Troubleshooting</b> . . . . .	3-1	
Section	II	<b>Maintenance Procedures</b> . . . . .	3-9	
Section	III	Preparation for Storage or Shipment . . . . .	3-59	
Section	IV	Preembarkation Inspection of Materiel in Units Alerted for Overseas Movement . . . . .	3-61	
APPENDIX	A	<b>REFERENCES</b> . . . . .	A-1	
APPENDIX	B	<b>MAINTENANCE ALLOCATION CHART</b> . . . . .	B-1	
APPENDIX	C	<b>ORGANIZATIONAL AND DIRECT SUPPORT MAINTENANCE REPAIR PARTS AND SPECIAL TOOLS LIST</b>		
Section	I	Introduction . . . . .	C-1	
Section	II	Repair Parts List . . . . .	C-1-1	

			Page	Illus/ Figure
<b>Group</b>	00	Submachine Gun, 5.56-MM: Port, Firing, M231 9327045 .....	C-1-1	C-1
	01	Drive Spring and Guide Assembly 11828593 .....	C-2-1	C-2
		0101 Retainer Assembly 9327063 .....	C-3-1	C-3
	02	Bolt Carrier and Striker Assembly 9327072 .....	C-4-1	C-4
		0201 Breech Bolt 9327073 .....	C-5-1	C-5
	03	Upper Receiver and Barrel Assembly 9327227 .....	C-6-1	C-6
		0304 Barrel and Barrel Collar Assembly 11828592 .....	C-6-1	C-6
		0301 Charging Handle Assembly 8448517.....	C-7-1	C-7
		0302 Upper Receiver Assembly 9327228 .....	C-8-1	C-8
		0303 Barrel Nut Assembly 8448552 .....	C-9-1	C-9
	04	Lower Receiver and Receiver Extension Assembly 9327230 .....	C-10-1	C-10
	9999	Bulk Material .....	BULK-1	
Section	III	Special Tools List .....	C-11-1	
	9500	Special Tools .....	C-11-1	C-11
Section	IV	National Stock Number and Part Number Index .....	I-1	
APPENDIX	D	EXPENDABLE/DURABLE SUPPLIES AND MATERIALS LIST .....	D-1	
APPENDIX	E	ILLUSTRATED LIST OF MANUFACTURED ITEMS .....	E-1	
		ALPHABETICAL INDEX .....	INDEX 1	

**HOW TO USE THIS MANUAL****GENERAL**

In order to use this manual efficiently, there are several things you need to know.

a. Warnings, cautions, and notes appear throughout the manual and are means of attracting attention to essential or critical information.

b. You must familiarize yourself with the entire maintenance procedure before beginning the maintenance task.

c. References in the manual are to pages, appendixes, or to other publications.

**INDEXES**

This manual has several useful indexes to help you quickly find the information needed:

a. Front Cover Index. Is a tabbed index of key sections and appendixes. Keyed to tabbed pages in the manual.

b. Table of Contents. Lists in order all chapters, sections, appendixes, and the alphabetical index. Gives page references.

c. Official Nomenclature, Names, and Designations. Gives an alphabetical list of common names and official nomenclature used in the manual.

d. Symptom Index. Located just before the troubleshooting table in each maintenance chapter. Lists in

alphabetical order the possible malfunctions. References pages of the troubleshooting table.

e. Alphabetical Index. Located at the end of the manual. An extensive subject index for everything in the manual. Gives page references.

---

**MAINTENANCE PROCEDURES**

---

Maintenance procedures found in chapters 2 and 3 are in two parts--summary procedures and detailed procedures. Procedures are in disassembly sequence as authorized in the maintenance allocation chart, appendix B.

a. Summary Procedure. Made up of two parts--initial setup and list of tasks. Used only when doing maintenance on the entire M231 submachine gun. (For maintenance of an individual assembly, use the detailed procedures for each maintenance task.)

(1) Initial Setup. Is a list of everything needed in order to do the maintenance task:

Tools and Special Tools--Lists tools needed to perform the maintenance tasks.

Materials/Parts--Lists expendable materials and 100% replaceable parts. Each material or part is followed by a part number or appendix reference. If more than one part is needed, the quantity needed precedes the part number or reference.

Personnel Required--Identifies the personnel required to perform the maintenance task.

References--Lists other publications, appendixes, and maintenance procedures containing necessary information.

Equipment Conditions--Lists conditions to be met before starting the procedure. The reference on the left of the condition is a page reference to instructions for setting up the condition. At the end of each condition is a reference to the task numbers in the list of tasks to which the condition applies.

General Safety Instructions--Includes any general safety information that applies throughout the procedure.

(2) List of Tasks. Summarizes in outline form the major tasks involved in the procedure. Gives page references to detailed procedures.

b. Detailed Procedures. Immediately follow each summary procedure. Also contain an initial setup plus step-by-step procedures.

(1) Initial Setup. Gives a list of everything needed in order to perform maintenance on each part of

the M231 submachine gun. See explanation of initial setup above.

(2) Step-By-Step Procedures. Are illustrated procedures for maintenance authorized in the maintenance allocation chart (MAC), appendix B, and the repair parts and special tools list (RPSTL), appendix C.

---

#### REPAIR PARTS AND SPECIAL TOOLS LIST

a. Repair Parts and Special Tools. Designed for organizational and direct support maintenance and are listed in appendix C.

b. Parts List. Is composed of functional groups, and follows MAC order. Parts in each group are listed in figure and item number sequence.

c. Illustrations. Illustrations and item numbers for repair parts authorized for organizational and direct support maintenance are in this manual.

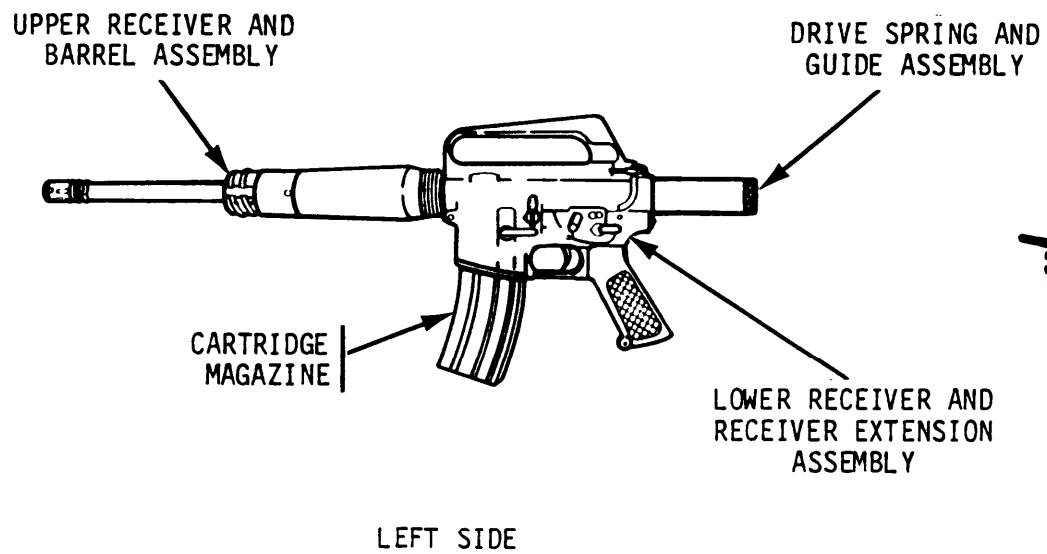
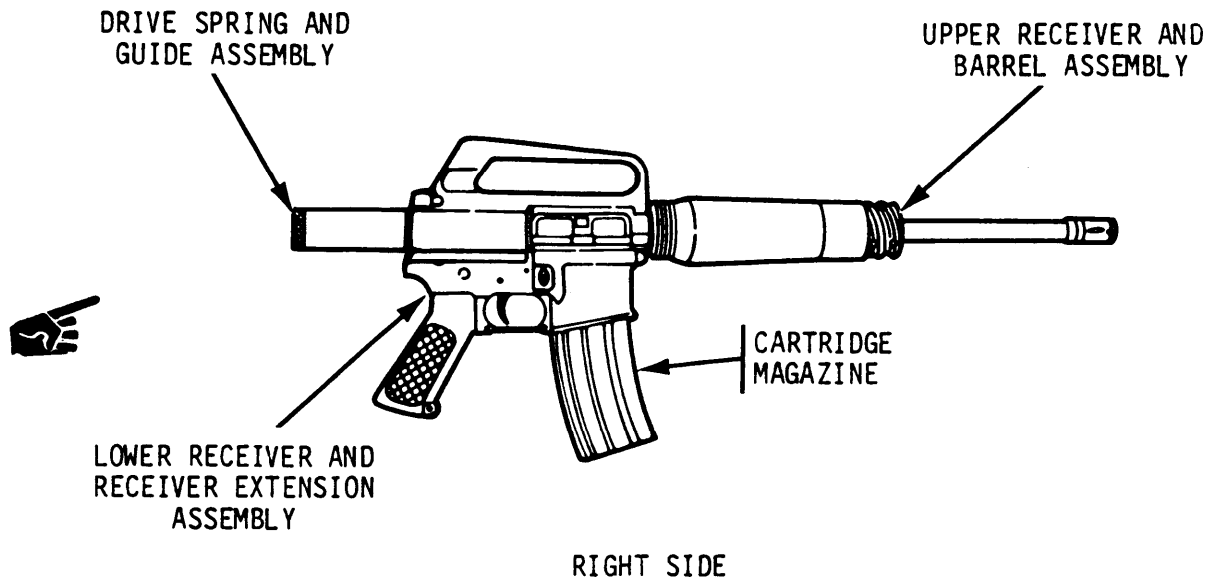

M231 SUBMACHINE GUN

# CHAPTER 1 INTRODUCTION

## Section I GENERAL INFORMATION

### 1-1. SCOPE

a. Type of Manual: Organizational and direct support maintenance (including repair parts and special tools list (RPSTL)).

b. Model Number and Equipment Name: M231 firing port 5.56-mm submachine gun.

c. Purpose of Equipment: To provide personnel inside vehicle a suppressive fire capability. M231 submachine gun can be removed for field use under emergency combat conditions. The weapon is not authorized for off-vehicle use during training.

### 1-2. MAINTENANCE FORMS, RECORDS, AND REPORTS

Department of the Army forms and procedures used for equipment maintenance will be those prescribed by DA PAM 738-750, The Army Maintenance Management System (TAMMS).

### 1-3. DESTRUCTION OF ARMY MATERIEL TO PREVENT ENEMY USE

Refer to TM 750-244-7.

### 1-4. PREPARATION FOR STORAGE OR SHIPMENT

Requirements for storage or shipment are listed on page 3-60.

### 1-5. OFFICIAL NOMENCLATURE, NAMES, AND DESIGNATIONS

#### Nomenclature Cross-Reference List

Common Name	Official Nomenclature
Barrel and extension assembly . . . . .	Barrel and barrel extension assembly
Barrier material . . . . .	Barrier material, grease-proofed-waterproofed
Fiberboard box . . . . .	Box, shipping
Gas metallic bent tube . . . . .	Tube, bent, metallic
Helical sear spring . . . . .	Spring, helical torsion
Inner helical compression spring . . . . .	Spring, helical compression
Lubricating oil (LSA) . . . . .	Lubricating oil, weapons
Middle helical compression spring . . . . .	Spring, helical compression
M231 submachine gun . . . . .	Submachine gun, 5.56-mm: port, firing, M231
Outer helical compression spring . . . . .	Spring, helical compression
Pressure sensitive tape . . . . .	Tape, pressure sensitive adhesive
Recoil buffer . . . . .	Buffer, recoil mechanism
Selector lever . . . . .	Fire control selector
Steel strapping . . . . .	Strapping
VCI treated material . . . . .	Paper, volatile corrosion inhibitor treated
Wooden box . . . . .	Box, shipping

1-6. REPORTING EQUIPMENT IMPROVEMENT RECOMMENDATIONS (EIR)

If your M231 submachine gun needs improvement, let us know. Send us an EIR. You, the user, are the only

one who can tell us what you don't like about your equipment. Let us know why you don't like the design. Put it on an SF 368 (Quality Deficiency Report). Mail it to us at: Commander, US Army Armament, Munitions and Chemical Command, ATTN: AMSMC-QAD, Rock Island, IL 61299-6000. We'll send you a reply.

## Section II REPAIR PARTS, SPECIAL TOOLS, TMDE AND SUPPORT EQUIPMENT

### 1-7. COMMON TOOLS AND EQUIPMENT

For authorized common tools and equipment refer to the Modified Table of Organization and Equipment (MTOE) applicable to your unit.

### 1-9. REPAIR PARTS

Repair parts are listed and illustrated in appendix C of this manual.

### 1-8. SPECIAL TOOLS, TMDE, AND SUPPORT EQUIPMENT

No support equipment or TMDE is required for the M231 submachine gun. Special tools are listed in appendix C of this manual.

## Section III. EQUIPMENT DESCRIPTION AND DATA

### 1-10. EQUIPMENT CHARACTERISTICS, CAPABILITIES, AND FEATURES

#### CHARACTERISTICS

- a. Lightweight
- b. Air cooled
- c. Gas operated
- d. Magazine fed
- e. Automatic fire

#### CAPABILITIES AND FEATURES

Has positive locking of the breech bolt. The breech bolt and the barrel and barrel collar assembly contain locking lugs which engage and lock the breech bolt firmly in the barrel and barrel collar assembly.

Firing hammer cannot strike the firing pin until the breech bolt is fully locked.

- b. Fires from open bolt carrier and striker assembly position.
- c. The trigger guard is easily adaptable to winter operations. A spring loaded retaining pin is depressed to allow ready access to the trigger when wearing arctic mittens.
- d. The ejection port cover prevents dirt or sand from getting into the ejection port of the upper receiver. The ejection port cover must be closed during periods when firing is not anticipated. It opens automatically by the forward or rearward movement of the bolt carrier and striker assembly.

## 1-11. LOCATION AND DESCRIPTION OF MAJOR COMPONENTS

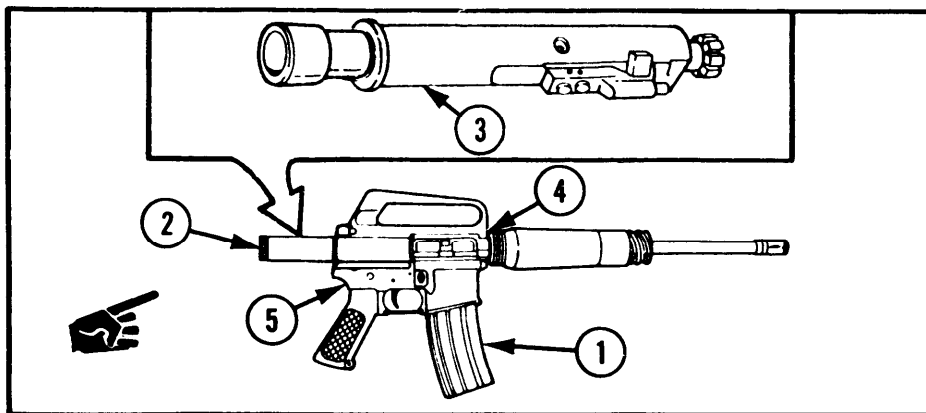

a. Cartridge Magazine (1). Has 30-cartridge capacity.

b. Drive Spring and Guide Assembly (2). Helical compression springs provide energy to feed and fire the weapon and act as a buffer for the bolt carrier

and striker assembly during recoil. Retainer assembly keeps helical compression springs alined in proper position to function.

c. Bolt Carrier and Striker Assembly (3). Carries breech bolt to chamber and fires the cartridge.

d. Upper Receiver and Barrel Assembly (4). Is air cooled, contains flash suppressor, barrel collar, two handguards, ejection port, and ejection port cover. Houses the bolt carrier and striker assembly.

Lower Receiver and Receiver Extension Assembly (5). Contains trigger, sear, selector lever, magazine catch, rifle grip, bolt catch, and the receiver extension. Houses the drive spring and guide assembly.

## 1-12 EQUIPMENT DATA

Refer to TM 9-1005-309-10 for the tabulated equipment data.

## Section IV. PRINCIPLES OF OPERATION

### 1-13. GENERAL

The M231 submachine gun is mounted in a vehicle ball socket providing suppressive fire to the sides and rear of the vehicle. Sighting is accomplished by viewing the tracer ammunition paths through periscopes on the vehicle.

### 1-14. PRINCIPLES OF OPERATION

a. Cartridge Magazine (1). Holds cartridges ready for feeding and provides a guide for positioning cartridges for stripping. Provides quick reloading capabilities for sustained firing.

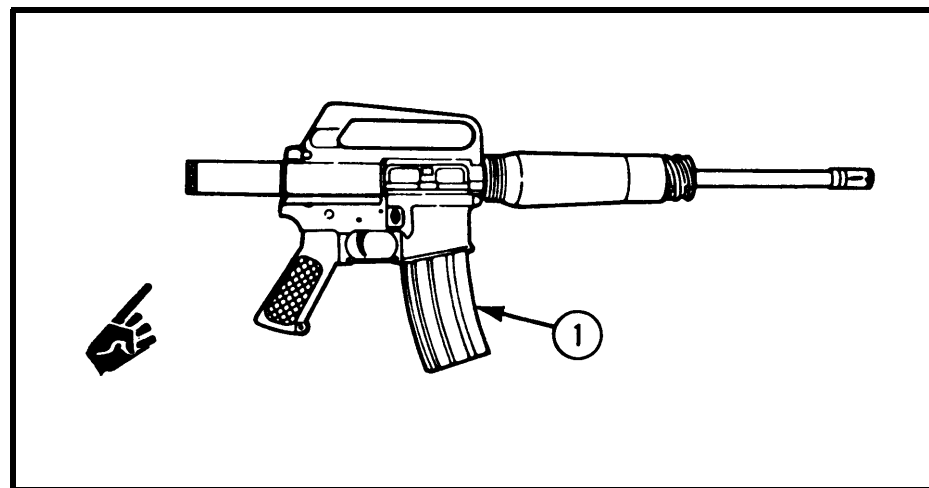

---

1-14. PRINCIPLES OF OPERATION (cont)

---

b. Drive Spring and Guide Assembly (2). Provides energy for returning bolt carrier and striker assembly to the firing position and provides a buffer to the recoiling bolt carrier and striker assembly after firing.

c. Bolt Carrier and Striker Assembly (3). Provides stripping, cambering, locking, firing, extraction, and ejection of cartridges using the helical compression springs and projectile propelling gases for power.

d. Upper Receiver and Barrel Assembly (4). Provides support for the bolt carrier and striker assembly. The barrel contains the cartridge for firing and directs the projectile. The barrel collar provides the means to mount the M231 submachine gun in the vehicle firing port.

Lower Receiver and Receiver Extension Assembly (5). Provides firing control for the M231 submachine gun.

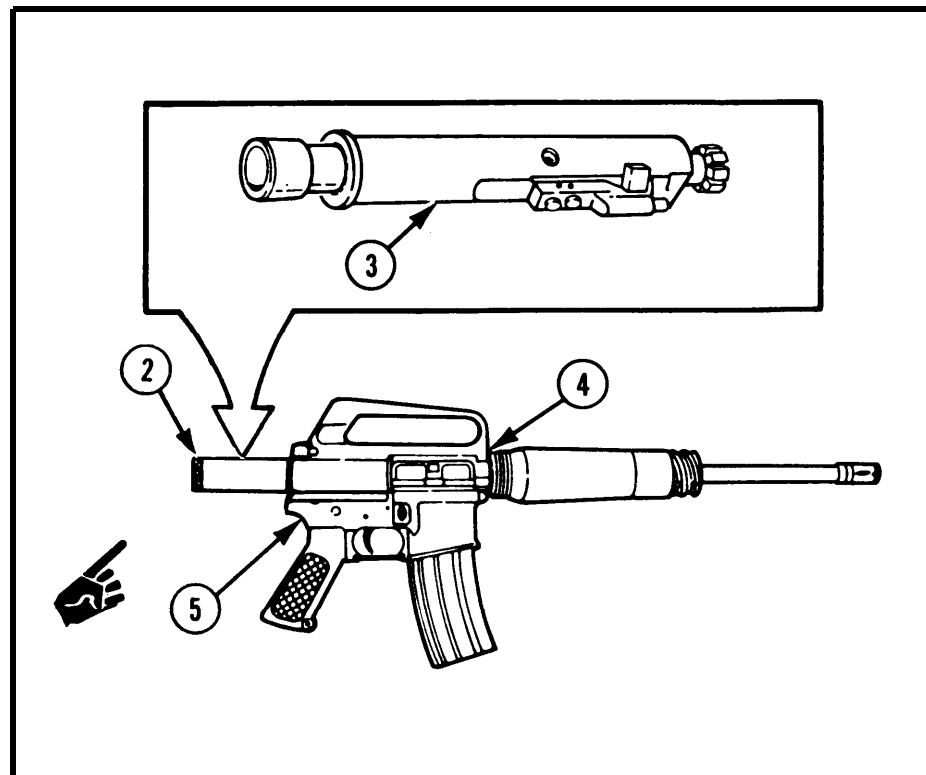

# CHAPTER 2

## ORGANIZATIONAL MAINTENANCE INSTRUCTIONS

### Section I SERVICE UPON RECEIPT

#### 2-1. SCOPE

This section contains instructions for services to be performed by the using organization upon the receipt of a new or overhauled M231 submachine gun. These services include unpacking, reprocessing, and checking the M231 submachine gun.

#### 2-2. SERVICE UPON RECEIPT OF MATERIEL

Table 2-1 contains instructions for performing those services required upon the receipt of this equipment.

Table 2-1. SERVICE UPON RECEIPT--M231 SUBMACHINE GUN

LOCATION	ITEM	ACTION	REMARKS
M231 submachine gun	1. M1231 submachine gun	Field strip.	Refer to TM 9-1005-309-10.
	2. all parts	a. Clean. b. Inspect. c. Lubricate.	Refer to TM 9-1005-309-10.
	3. M231 submachine gun	a. Reassemble. b. Perform functional check.	a. Refer to TM 9-1005-309-10. b. Refer to TM 9-1005-309-10.

## 2-2. SERVICE UPON RECEIPT OF MATERIEL (cont)

Table 2-1. SERVICE UPON RECEIPT--M231 SUBMACHINE GUN (cont)

LOCATION	ITEM	ACTION	REMARKS
	3. M231 submachine gun (cont)	<p>c. Insert <u>empty</u> cartridge magazine. Pull charging handle assembly to the rear. Return charging handle assembly.</p> <p>d. Pull trigger.</p> <p>e. Press bolt catch to release bolt carrier and striker assembly. Pull trigger.</p>	<p>c. Bolt carrier and striker assembly should lock to the rear.</p> <p>d. Bolt carrier and striker assembly should not go forward.</p> <p>e. Bolt carrier and striker assembly should go forward.</p>

## 2-3. CHECKING UNPACKED EQUIPMENT

Inspect the equipment for damage incurred during shipment. If the equipment has been damaged, report the damage on SF 364, Report of Discrepancy (ROD).

b. Check the equipment against the packing slip to see if the shipment is complete. Report all discrepancies in accordance with the instructions of DA PAM 738-750.

c. Check to see whether the equipment has been modified.

## Section II PREVENTIVE MAINTENANCE CHECKS AND SERVICES (PMCS)

### 2-4. GENERAL

**NOTE**

An inactive weapon is a weapon, whether assigned or not assigned to an individual, that is stored in an arms room for a period of 90 days. Normal cleaning (PMCS) of an inactive weapon will be performed every 90 days.

- a. Perform PMCS every 90 days to keep the weapon ready for use.
- b. If the weapon has not been used for 90 days, PMCS in the operator's manual (TM 9-1005-309-10) also should be performed. If you see rust on a weapon, the PMCS should be done immediately.
- c. An annual technical inspection by direct support maintenance is required for the M231 submachine gun.

### 2-5. PREVENTIVE MAINTENANCE CHECKS AND SERVICES

Table 2-2 lists those preventive maintenance checks and services to be performed quarterly. The table consists of three columns.

- a. Column 1, Item No. The first column contains the item number which shall be used as a source of item numbers for the TM Number Column on DA Form 2404, Equipment Inspection and Maintenance Worksheet, in recording results of PMCS.
- b. Column 2, Item to be Inspected. The second column lists the item to be inspected.
- c. Column 3, Procedures. The third column contains the illustrated procedures to be followed.

Table 2-2. ORGANIZATIONAL PREVENTIVE MAINTENANCE CHECKS AND SERVICES  
QUARTERLY SCHEDULE

Item No.	Item To Be Inspected	Procedures	
		<p><b>WARNING</b></p> <p>Before starting an inspection, be sure to clear M231 submachine gun. Live ammunition should not be near the work area.</p>	



## 2-5. PREVENTIVE MAINTENANCE CHECKS AND SERVICES (cont)

Table 2-2. ORGANIZATIONAL PREVENTIVE MAINTENANCE CHECKS AND SERVICES  
QUARTERLY SCHEDULE (cont)

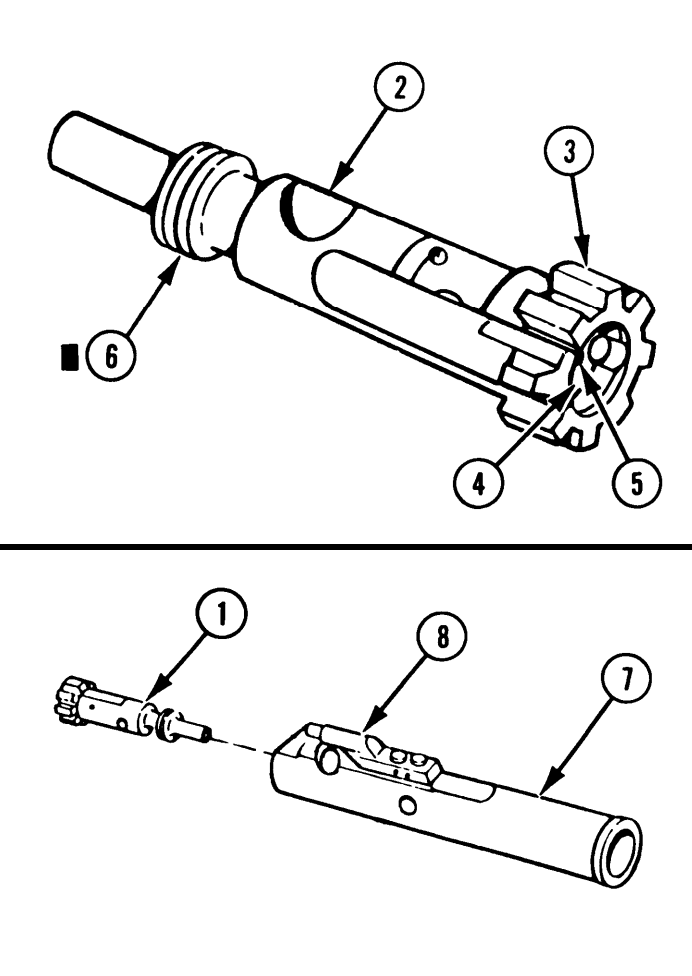
Item No.	Item To Be Inspected	Procedures	
1	Bolt carrier and striker assembly	<p style="text-align: center;"><b>WARNING</b></p> <p>To avoid possible explosion, never exchange or switch bolt carrier and striker assembly from one weapon to another.</p> <p>a. Disassemble (p 2-24).</p> <p>b. Check breech bolt (1) for cracks in the area of bolt cam pin hole (2)</p> <p>c. Check for cracks on locking lugs (3), pitted or chipped breech bolt Face (4), and that the firing pin hole (5) is still round.</p> <p>d. Check for worn bolt rings (6). If breech bolt will fall out of bolt carrier and key assembly (7) when it is in the down position, the bolt rings are defective.</p> <p>e. Check key (8) for damage or looseness.</p> <p>f. If any of the above show defects, notify direct support maintenance.</p>	

2

Breech bolt

- a. Remove cartridge extractor (1), extractor pin (1.1), and extractor spring assembly (2) (p 2-28). Check-cartridge extractor (1) for cracks and make sure cartridge extractor lip is sharp and free of burrs and chips. Check extractor spring assembly (2) for kinks or damaged insert. Replace cartridge extractor and extractor spring assembly (p 2-28) if defective.
- b. Clean breech bolt hole (3) with small arms cleaning brush (TM 9-1005-309-10) dipped in rifle bore cleaning compound (RBC) (item 8, app D); lubricate with lubricating oil (LSA) (item 16, app D); and reassemble (p 2-28).
- c. Reassemble weapon (TM 9-1005-309-10).

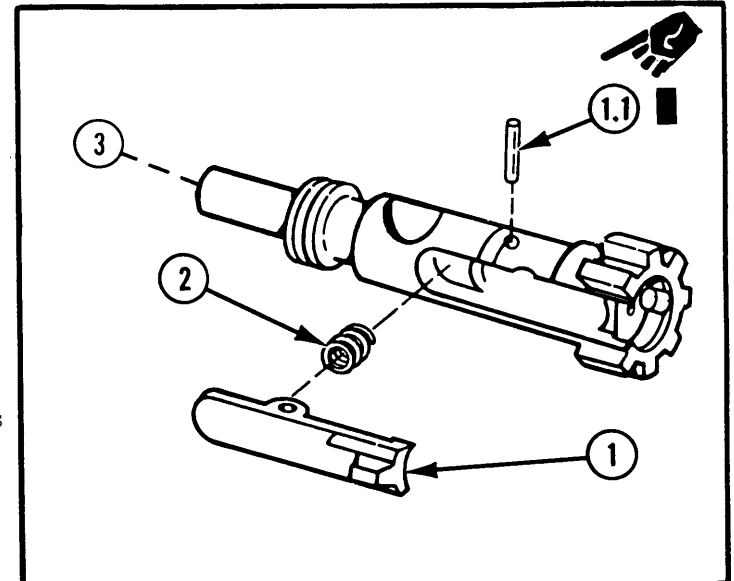

3

Upper receiver and barrel assembly

- a. Remove both handguards (1) (step 2, p 2-31).
- b. Inspect handguards internally and externally for cracks and/or damage. Handguard can have cracks up to 1 in. (2.54 cm) long.
- c. Replace handguards (p 2-31) if three rivets (2) are missing, if the liner (3) is loose enough to rattle, if handguard is cracked more than 1 in. (2.54 cm) in length, or if two or more tabs are missing from a handguard.

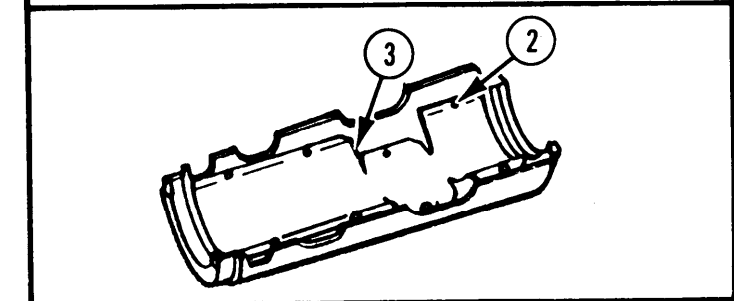
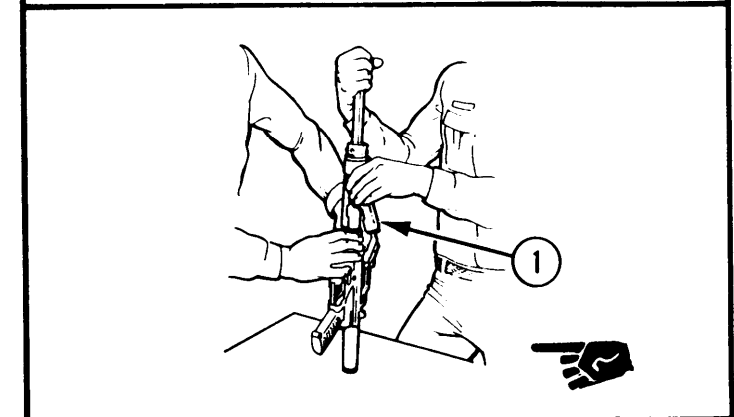

## 2-5. PREVENTIVE MAINTENANCE CHECKS AND SERVICES (cont)

Table 2-2. ORGANIZATIONAL PREVENTIVE MAINTENANCE CHECKS AND SERVICES  
QUARTERLY SCHEDULE (cont)

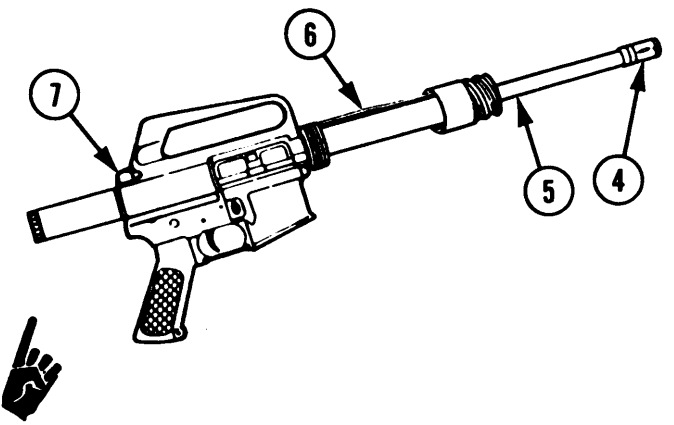
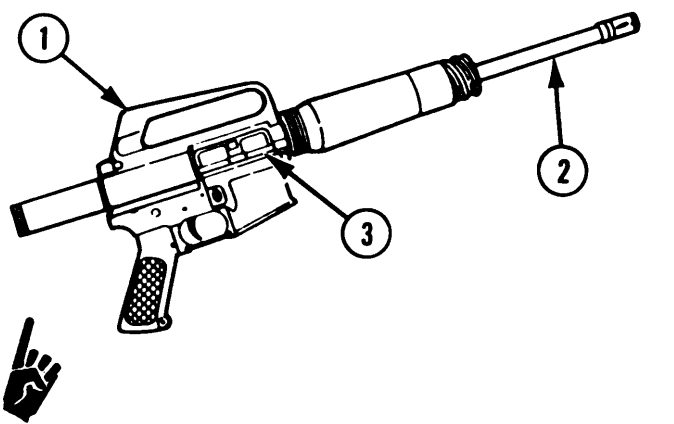
Item No.	Item To Be Inspected	Procedures	
3	Upper receiver and barrel assembly (cont)	<p>d. Hand check flash suppressor (4) for looseness on barrel and extension assembly (5). If loose, notify direct support maintenance.</p> <p>e. Check gas metallic bent tube (6) for damage. If damaged, notify direct support maintenance.</p> <p>f. Install handguards (p 2-32).</p> <p>g. Check charging handle assembly (7) for defects (p 2-33). If defective, replace or repair.</p>	
4	Upper receiver assembly	<p>a. Hand check upper receiver (1) for looseness on barrel and extension assembly (2). If loose, notify direct support maintenance.</p> <p>b. Check ejection port cover (3) for freedom of movement when opening or closing. Replace (p 2-35) if defective.</p> <p>c. Inspect finish of upper receiver (1). Repair (p 2-35) if scratched or worn shiny. If one-third or more of the exterior protective finish is missing, notify direct support maintenance.</p>	

5

Lower receiver and receiver extension assembly

- a. Check for frozen detents and springs.
- b. Clean all detents and springs, take-down pin (1), pivot pin (2), selector lever (3), and outer surface of lower receiver (4) with small arms cleaning brush (TM 9-1005-309-10) dipped in rifle bore cleaning compound (RBC) (item 8, app D).
- c. Hand check lower receiver (4) for looseness on barrel and extension assembly (5). If loose, notify direct support maintenance.
- d. Function check magazine catch (6), and adjust (TM 9-1005-309-10). If defective, notify direct support maintenance.
- e. Check for bent or broken trigger (7) and trigger guard (8). If defective, notify direct support maintenance.
- f. Check for corroded or damaged lower receiver (4). If damaged, notify direct support maintenance.
- g. Check for cracked or damaged rifle grip (9). If damaged, replace (p 2-38).
- h. Check receiver extension (10) for looseness. If loose, notify direct support maintenance.

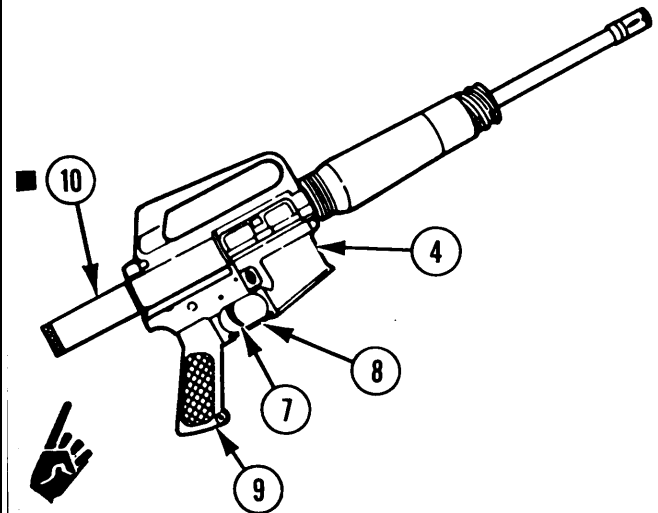
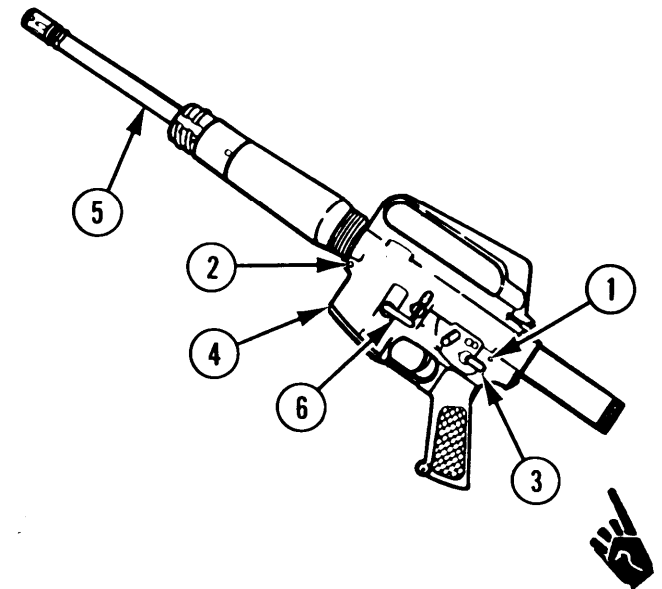

### Section III. TROUBLESHOOTING

2-6. TROUBLESHOOTING INFORMATION

a. The symptom index can be used as a quick guide to troubleshooting. Common malfunctions are listed in alphabetical order with a page number reference to the troubleshooting table where a test or inspection and corrective action are provided.

b. Table 2-3 lists the malfunction, the test or inspection indicating the malfunction, and the correc-

tive action needed. There are illustrations to show location of parts. This manual cannot list all malfunctions that may occur, nor all tests or inspections and corrective actions. If the malfunction is not listed or if the malfunction still exists after all listed corrective actions have been performed, notify direct support maintenance.

SYMPTOM INDEX

	Troubleshooting Procedure Page
M231 SUBMACHINE GUN	
Fails to chamber .....	2-9
Fails to eject .....	2-10.2
Fails to extract .....	2-10.2
Fails to feed .....	2-9
Fails to fire .....	2-10.1
Fails to lock .....	2-10
Fails to lock to rear .....	2-11
Fails to lock to rear after last round .....	2-11
Fails to unlock .....	2-10.1

Table 2-3. TROUBLESHOOTING

MALFUNCTION TEST OR INSPECTION CORRECTIVE ACTION	LOCATION
--	----------

**WARNING**

Before starting any procedures on the M231 submachine gun, be sure to clear weapon.

1. FAILS TO FEED.

Step 1. Check for defective helical compression spring (1) in magazine catch.

Notify direct support maintenance.

Step 2. Check to see if magazine catch (2) is worn or broken.

Notify direct support maintenance.

Step 3. Check if magazine catch (2) is out of adjustment.

Adjust magazine catch. Press magazine catch button (use cleaning rod or a cartridge) until the magazine catch (2) protrudes beyond the left side of lower receiver. To tighten, turn the magazine catch (2) clockwise. To loosen, turn it counterclockwise.

Step 4. Check drive spring and guide assembly for broken helical compression springs (3).

Replace broken helical compression springs (p 2-19).

Step 5. Check for defective cartridge magazine (4).

Replace defective cartridge magazine (p 2-15).

2. FAILS TO CHAMBER.

Check to see if helical compression springs (1, 2, and 3) are weak or broken (p 2-19).

Replace defective helical compression springs (p 2-19).

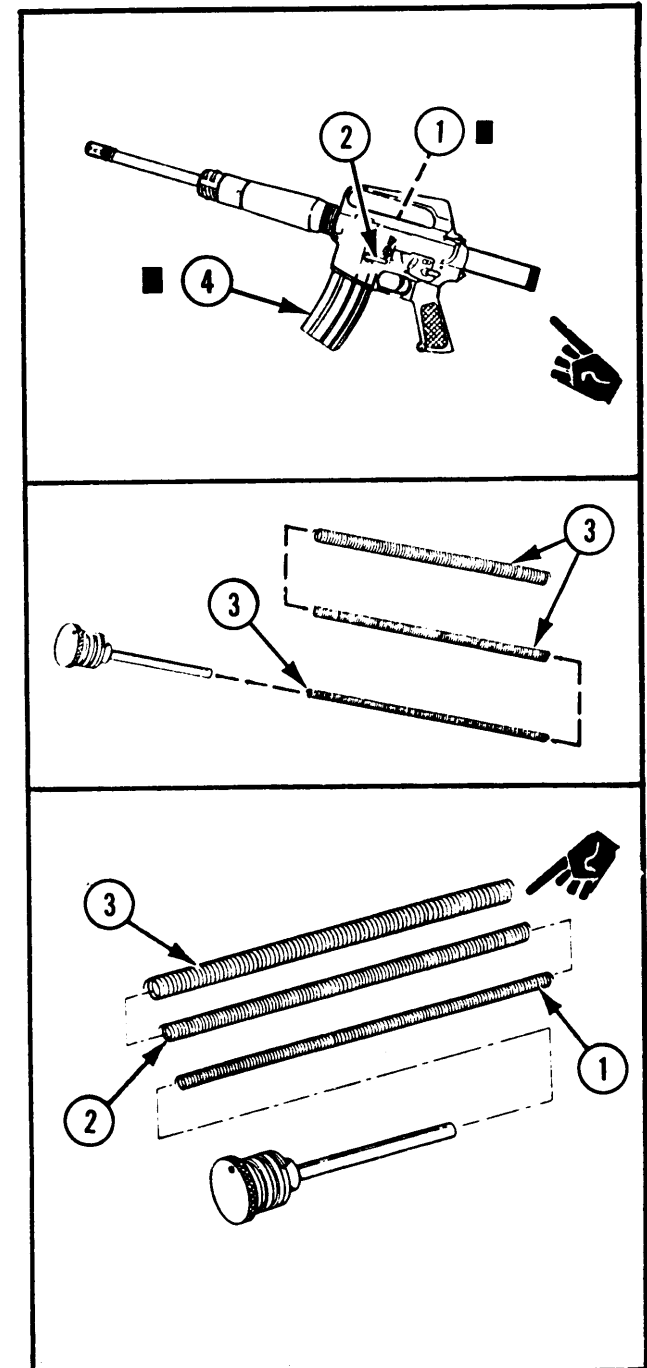

## 2-6. TROUBLESHOOTING INFORMATION (cont)

Table 2-3. TROUBLESHOOTING (cont)

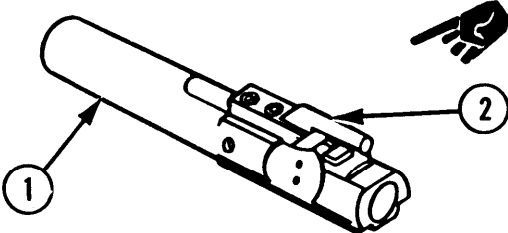
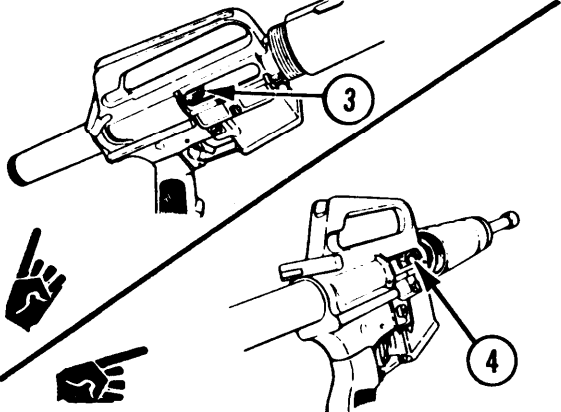
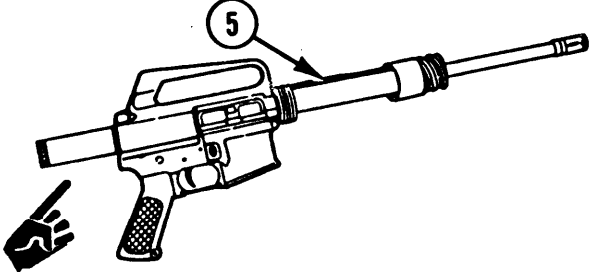
MALFUNCTION	TEST OR INSPECTION	CORRECTIVE ACTION	LOCATION
3. FAILS TO LOCK.	<p>Step 1. Check bolt carrier and key assembly (1) to see if key (2) is loose or damaged.</p>	<p>a. If dented, repair using key tool (p 2-24).</p> <p>b. Notify direct support maintenance.</p>	
	<p>Step 2. Check for defective breech bolt locking lugs (3).</p>	<p>Notify direct support maintenance.</p>	
	<p>Step 3. Check for defective mating locking lugs (4) in barrel and extension assembly.</p>	<p>Notify direct support maintenance.</p>	
	<p>Step 4. Check end of gas metallic bent tube (5) for damage.</p>	<p>Notify direct support maintenance.</p>	

Step 5. Check to see if helical compression springs (6, 7, and 8) are weak or broken.

Replace defective helical compression springs (p 2-19).

#### 4. FAILS TO FIRE.

Step 1. Check for frozen or broken firing pin (2).

Notify direct support maintenance.

Step 2. Check for chipped point or broken firing pin (2).

Notify direct support maintenance.

#### 5. FAILS TO UNLOCK.

Step 1. Check for burred locking lugs (1) on breech bolt (2).

Notify direct support maintenance.

Step 2. Check for burred locking lugs (3) on barrel and extension assembly (4).

Notify direct support maintenance.

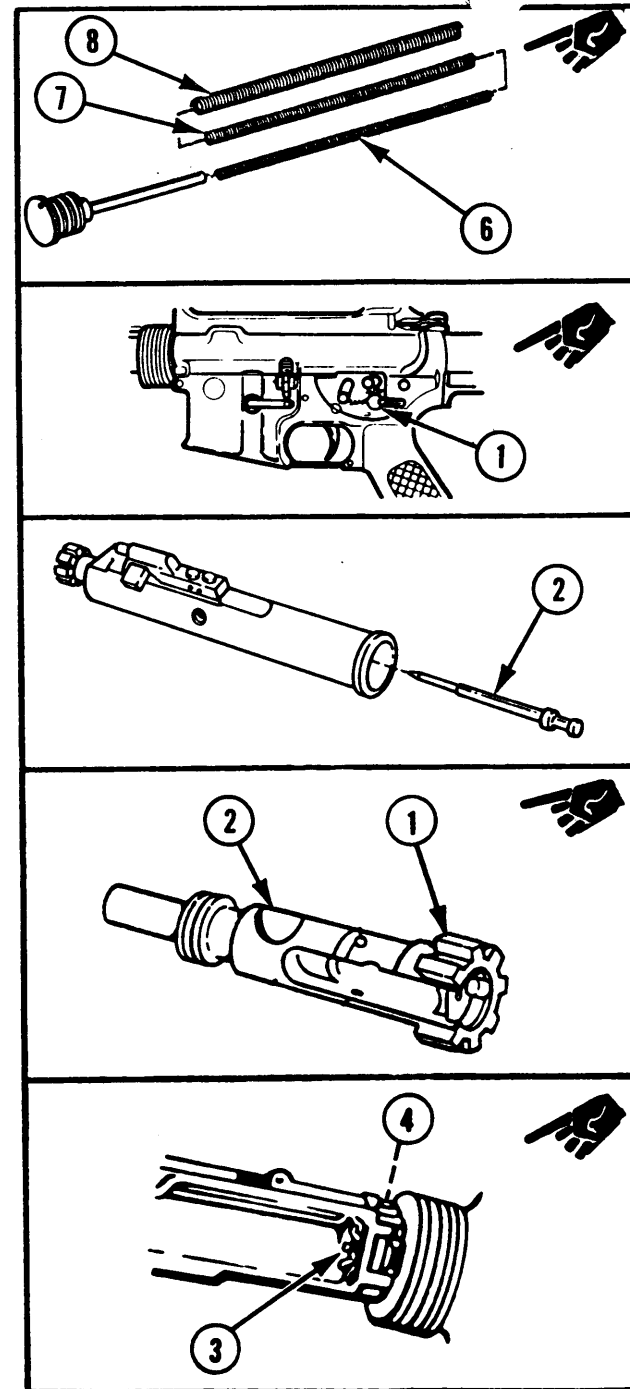

2-6. TROUBLESHOOTING INFORMATION (cont)

Table 2-3. TROUBLESHOOTING (cont)

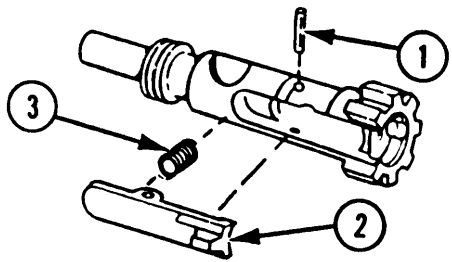
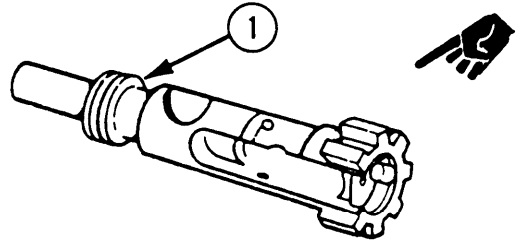
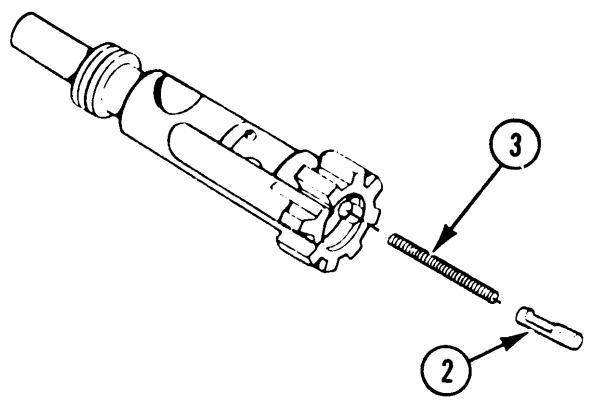
<p>MALFUNCTION TEST OR INSPECTION CORRECTIVE ACTION</p>	<p>LOCATION</p>
<p>6. FAILS TO EXTRACT.</p> <p>Check breech bolt for defective extractor pin (1), cartridge extractor (2), and extractor spring assembly (3).</p> <p>Replace defective parts (p 2-28).</p>	
<p>7. FAILS TO EJECT.</p> <p>Step 1. Check to see if bolt rings (1) are worn, broken or missing; and that gaps are staggered.</p> <ul style="list-style-type: none"> <li>a. Notify direct support maintenance if bolt rings are worn, broken, or missing.</li> <li>b. If gaps are not staggered, adjust <b>gaps</b> until they are equally spaced.</li> </ul>	
<p>Step 2. Check for frozen cartridge ejector (2).</p> <p>Clean (p 2-28).</p> <p>Step 3. Check cartridge ejector (2) for improper installation.</p> <p>Install correctly (p 2-28).</p> <p>Step 4. Check for broken cartridge ejector (2).</p> <p>Replace defective cartridge ejector (p 2-28).</p> <p>Step 5. Check for broken or weak helical compression spring (3).</p> <p>Replace defective helical compression spring (p 2-28).</p>	

8. FAILS TO LOCK TO REAR.

Step 1. Check for weak or broken helical sear spring (1).

Notify direct support maintenance.

Step 2. Check to see if sear (2) is worn or broken.

Notify direct support maintenance .

Step 3. Check to see if bolt carrier and key assembly sear notch (3) is worn.

Notify direct support maintenance.

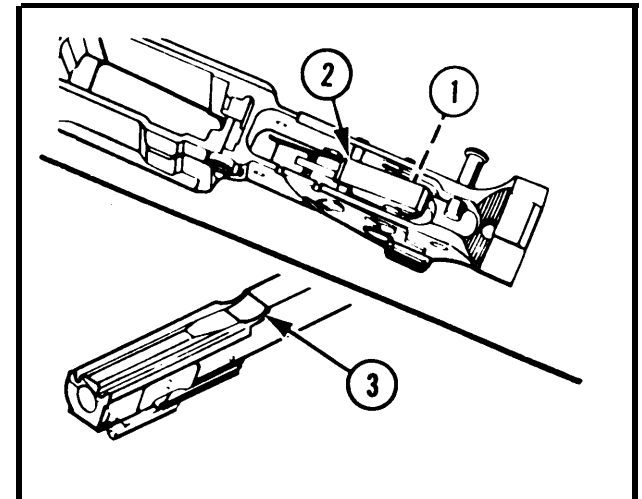

9. FAILS TO LOCK TO REAR AFTER LAST ROUND.

Step 1• Check for broken bolt catch (1).

Notify direct support maintenance.

Step 2. Check to see if helical compression spring (2) is broken or weak.

Notify direct support maintenance.

Step 3. Check for defective cartridge magazine (3).

Replace defective cartridge magazine (p 2-15).

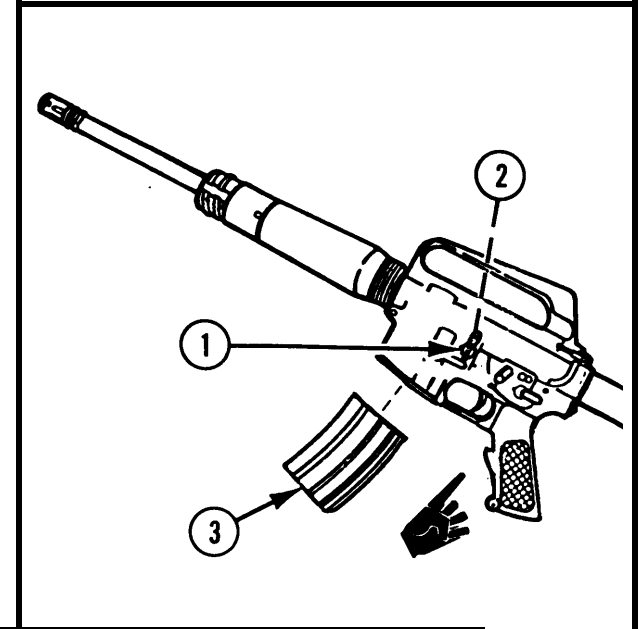

## Section IV. MAINTENANCE PROCEDURES

### 2-7. M231 SUBMACHINE GUN--MAINTENANCE INSTRUCTIONS

#### INITIAL SETUP

##### Tools and Special Tools

- Key tool (C-II, app C)
- Pivot pin removing tool (fig. 2, app E)
- Small arms cleaning brush (11686340)
- Small arms repairman tool kit (SC 5180-95-CL-A07)

##### Materials/Parts

- Abrasive cloth (item 9, app D)
- Artist's brush (item 5, app D)
- Dry cleaning solvent (item 10, app D)
- Lubricating oil (LSA) (item 16, app D)
- Protective gloves (item 10.1, app D)
- Rifle bore cleaning compound (RBC) (item 8, app D)
- Small arms cleaning swab (item 20, app D)
- Solid film lubricant (item 13, app D)
- Tobacco pipe cleaner (item 7, app D)
- Tools and parts cleaning brush (item 6, app D)
- Wiping rag (item 18, app D)

##### Personnel Required

- MOS 76Y-10 Supply clerk/unit armorer
- Helper

##### References

- Appendix C
- Appendix D
- TM 9-1005-309-10

##### Equipment Conditions

- 2-19 Retainer assembly removed (task no. 3)
- 2-15 Bolt carrier and striker assembly removed (task no. 4)
- 2-24 Breech bolt removed from bolt carrier and striker assembly (task no. 5)
- 2-15 Upper receiver and barrel assembly removed (tasks no. 6 and 8)
- 2-15 Lower receiver and receiver extension assembly removed (task no. 9)

##### General Safety Instructions

#### WARNING

Before starting any procedures on the M231 submachine gun be sure to clear weapon. Live ammunition should not be near the work area.

To avoid possible explosion, never exchange or switch bolt carrier and striker assembly from one weapon to another.

#### NOTE

Cleaner, Lubricant and Preservative (CLP) is not authorized for use on this weapon.

LIST OF TASKS

Task No.	Task	Task Ref (Page)
1	Maintain M231 submachine gun:  a. Inspect. b. Disassemble. c. Repair. d. Reassemble.	2-16 2-16 2-17 2-18
2	Maintain drive spring and guide assembly:  a. Remove/disassemble. b. Clean. c. Inspect. d. Repair. e. Reassemble/install.	2-19 2-20 2-20 2-21 2-21
3	Maintain retainer assembly:  a. Disassemble. b. Clean. c. Inspect. d. Repair. e. Reassemble.	2-22 2-22 2-23 2-23 2-23
4	Maintain bolt carrier and striker assembly:  a. Disassemble. b. Clean. c. Inspect. d. Repair. e. Reassemble.	2-25 2-25 2-26 2-26 2-27

## 2-7. M231 SUBMACHINE GUN--MAINTENANCE INSTRUCTIONS (cont)

## LIST OF TASKS (cont)

Task No.	Task	Task Ref (Page)
5	Maintain breech bolt: <ul style="list-style-type: none"> <li>a. Disassemble.</li> <li>b. Clean.</li> <li>c. Inspect.</li> <li>d. Repair.</li> <li>e. Reassemble.</li> </ul>	2-28 2-29 2-29 2-30 2-30
6	Maintain upper receiver <b>and</b> barrel assembly: <ul style="list-style-type: none"> <li>a. Disassemble.</li> <li>b. Inspect. Repair.</li> <li>d. Reassemble.</li> </ul>	2-31 2-32 2-32 2-32
7	Maintain charging handle assembly: <ul style="list-style-type: none"> <li>a. Remove.</li> <li>b. Disassemble.</li> <li><b>c.</b> Inspect.</li> <li>d. Repair.</li> <li><b>e.</b> Reassemble.</li> <li>f. Install.</li> </ul> Maintain upper receiver assembly: <ul style="list-style-type: none"> <li><b>a.</b> Disassemble.</li> <li>b. Clean.</li> <li>c. Inspect.</li> <li>d. Repair.</li> <li>e. Reassemble.</li> </ul>	2-34 2-34 2-34 2-34 2-35 2-35 2-36 2-36 2-37 2-37 2-38

9	Maintain lower receiver and receiver extension assembly: <ul style="list-style-type: none"> <li>a. Disassemble.</li> <li>b. Clean.</li> <li>c. Inspect.</li> <li>d. Repair.</li> <li>e. Reassemble.</li> </ul>	2-39 2-40 2-41 2-41 2-41
---	--	--------------------------------------

2-8. M231 SUBMACHINE GUN--MAINTENANCE INSTRUCTIONS

THIS TASK COVERS: <table style="width: 100%; border: none;"> <tr> <td style="width: 50%; vertical-align: top; padding: 5px;"> <ul style="list-style-type: none"> <li>a. Inspection</li> <li>b. Disassembly</li> </ul> </td> <td style="width: 50%; vertical-align: top; padding: 5px;"> <ul style="list-style-type: none"> <li>c. Repair</li> <li>d. Reassembly</li> </ul> </td> </tr> </table>		<ul style="list-style-type: none"> <li>a. Inspection</li> <li>b. Disassembly</li> </ul>	<ul style="list-style-type: none"> <li>c. Repair</li> <li>d. Reassembly</li> </ul>
<ul style="list-style-type: none"> <li>a. Inspection</li> <li>b. Disassembly</li> </ul>	<ul style="list-style-type: none"> <li>c. Repair</li> <li>d. Reassembly</li> </ul>		
INITIAL SETUP  Tools and Special Tools <ul style="list-style-type: none"> <li>Small arms repairman tool kit (SC 5180-95-CL-A07)</li> </ul> Personnel Required <ul style="list-style-type: none"> <li>MOS 76Y-10    Supply clerk/unit armorer</li> </ul> References <ul style="list-style-type: none"> <li>Appendix C</li> </ul>	General Safety Instructions  <p style="text-align: center;"><b>WARNING</b></p> Before starting any procedures on the M231 submachine gun be sure to clear weapon. Live ammunition should not be near the work area.  <p style="text-align: center;"><b>NOTE</b></p> Cleaner, Lubricant and Preservative (CLP) is not authorized for use on this weapon.		

2-8. M231 SUBMACHINE GUN--MAINTENANCE INSTRUCTIONS (cont)

INSPECTION

- 1 Check that all sliding parts move freely and smoothly.
- 2 Check to see that all spring loaded pins are movable.
- 3 Check for obstruction in bore, upper receiver and barrel assembly, and cartridge magazine.
- 4 Check cartridge magazine for damage.
- 5 Check for burrs. If present, remove with a stone.
- 6 Check for corrosion.

**WARNING**

Be careful when removing spring loaded parts. Carelessness could result in injury.

- 3 DRIVE SPRING AND GUIDE ASSEMBLY (3). With bolt carrier and striker assembly forward, turn counterclockwise and remove.

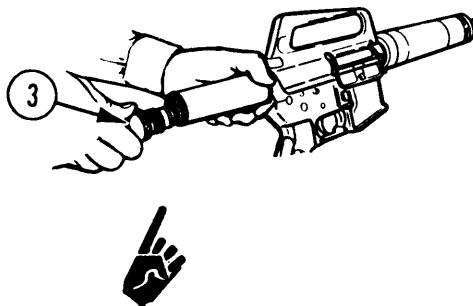

DISASSEMBLY

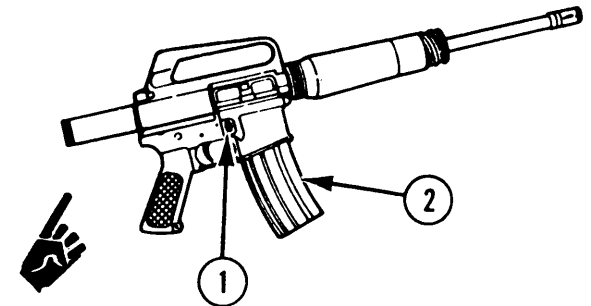

- 1 MAGAZINE CATCH BUTTON (1). Press.

- 2 CARTRIDGE MAGAZINE (2). Pull down and remove.

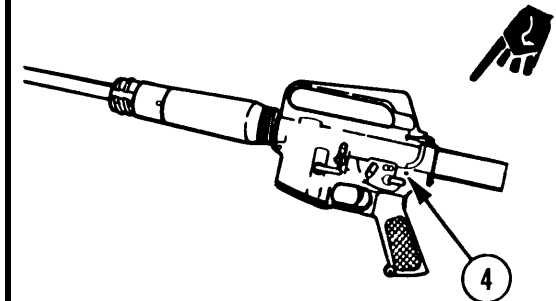

- 4 TAKEDOWN PIN (4). Push in as far as it will go.

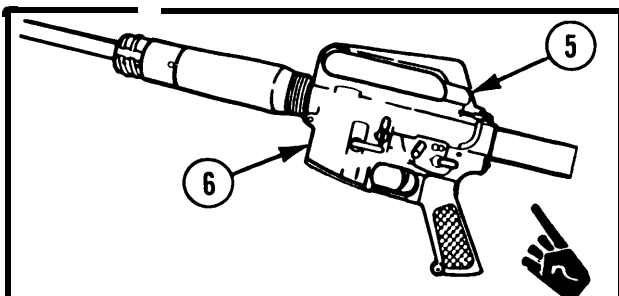

**CAUTION**

Do not drop firing hammer when pivoting the upper receiver and barrel assembly.

- 5 UPPER RECEIVER AND BARREL ASSEMBLY (5). Pivot from lower receiver and receiver extension assembly (6).

6 PIVOT PIN (7). Push as far as it goes.

7 UPPER RECEIVER AND BARREL ASSEMBLY (5). Remove from lower receiver and receiver extension assembly (6).

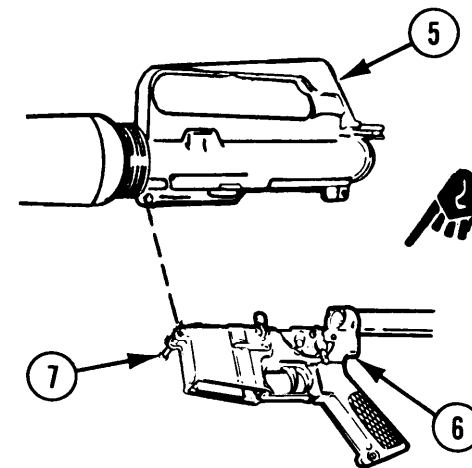

**REPAIR**

**NOTE**

The firing hammer is part of the bolt carrier and striker assembly.

- 8 FIRING HAMMER (8). Tilt upper receiver and barrel assembly and remove firing hammer.
- 9 BOLT CARRIER AND KEY ASSEMBLY (9) WITH ATTACHED PARTS. Pull charging handle assembly (10) and tilt upper receiver and barrel assembly to remove.

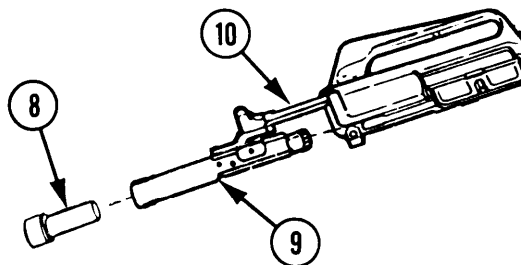

Repair is by replacement of authorized parts (app C) as required.

2-8. M231 SUBMACHINE GUN--MAINTENANCE INSTRUCTIONS (cont)

REASSEMBLY

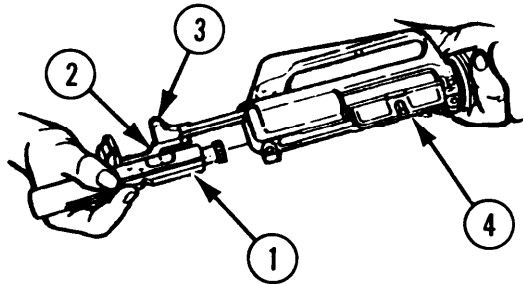

**NOTE**

Breech bolt must be in its forward-rest position in the bolt carrier and key assembly.

- 1 BOLT CARRIER AND KEY ASSEMBLY (1) WITH ATTACHED PARTS. Alne key (2) with charging handle assembly (3) and slide into upper receiver and barrel assembly (4).

- 2 FIRING HAMMER (5). Install.  
 3 UPPER RECEIVER AND BARREL ASSEMBLY (4). Alne with lower receiver and receiver extension assembly (6).  
 4 PIVOT PIN (7). Push back into place.

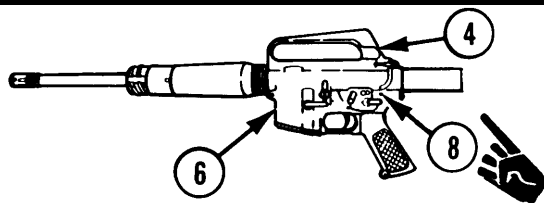
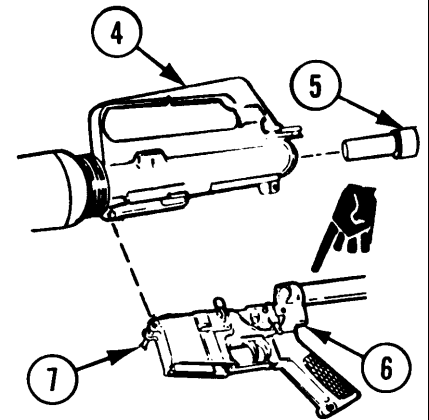

- 5 UPPER RECEIVER AND BARREL ASSEMBLY (4).  
 a. Pivot back in position with lower receiver and receiver extension assembly (6).  
 b. Secure by pushing in on takedown pin (8).

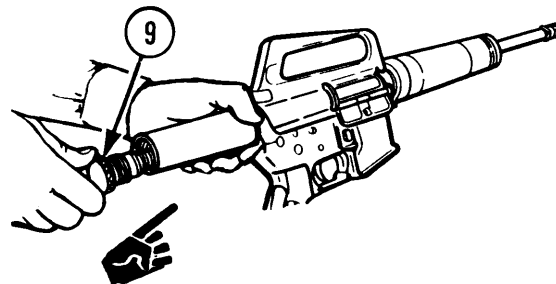

- 6 DRIVE SPRING AND GUIDE ASSEMBLY (9). Install and turn clockwise to lock in place.

■ Art deletd.

7 ■ Deleted.

## 2-9. DRIVE SPRING AND GUIDE ASSEMBLY--MAINTENANCE INSTRUCTIONS

### THIS TASK COVERS:

- a. Removal/disassembly
- b. Cleaning
- c. Inspection
- d. Repair
- e. Reassembly/installation

### INITIAL SETUP

#### Tools and Special Tools

Small arms repairman tool kit (SC 5180-95-CL-A07)

#### Materials/Parts

Lubricating oil (LSA) (item 16, app D)

Wiping rag (item 18, app D)

#### Personnel Required

MOS 76Y-10 Supply clerk/unit armorer

#### References

Appendix C

Appendix D

#### General Safety Instructions

#### **WARNING**

Before starting any procedures on the M231 sub-machine gun be sure to clear weapon. Live ammunition should not be near the work area.

### REMOVAL/DISASSEMBLY

#### **WARNING**

Be careful when removing spring loaded parts. Carelessness could result in injury.

- 1 DRIVE SPRING AND GUIDE ASSEMBLY ( 1). Turn counterclockwise and remove.

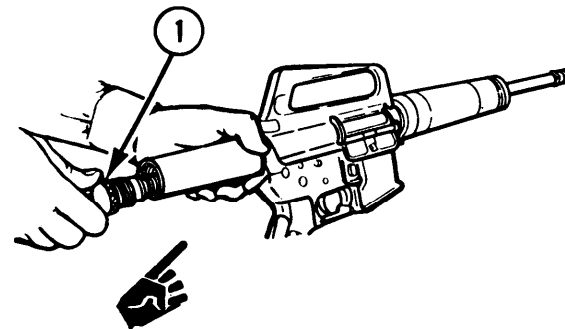

2-9. DRIVE SPRING AND GUIDE ASSEMBLY--MAINTENANCE INSTRUCTIONS (cont)

REMOVAL/DISASSEMBLY (cont)

2 OUTER HELICAL COMPRESSION SPRING (2), MIDDLE HELICAL COMPRESSION SPRING (3), AND INNER HELICAL COMPRESSION SPRING (4). Remove from retainer assembly (5).

3 FLAT WASHER (6) AND RECOIL BUFFER (7). Remove from retainer assembly (5).

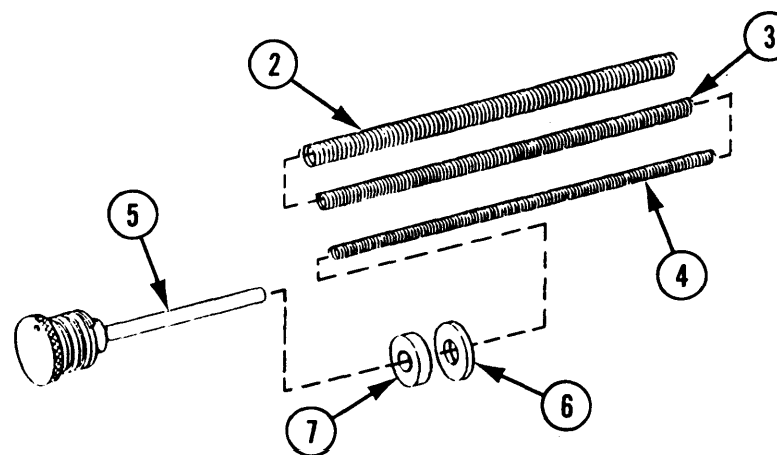

CLEANING

ALL PARTS. Wipe off with wiping rag (item 18, app D).

INSPECTION

- 1 HELICAL COMPRESSION SPRINGS.
  - a. Check for breaks or kinks.
  - b. Measure free length of springs with steel tape measure.
    - (1) The outer and middle spring's free length is between 9 5/8 and 10 3/8 in. (24.5 and 26.4 an).
    - (2) Inner spring's free length will between 7 1/8 and 7 5/8 in. (18.1 and 19.4 cm).
- 2 ALL REMAINING PARTS.
  - a. Check for bends, breaks, or other deformation.
  - b. Check for burrs. If present, remove with a stone.

## REPAIR

Repair is by replacement of authorized parts (app C) as required.

### NOTE

For repair of the retainer assembly refer to page 2-22.

## REASSEMBLY/INSTALLATION

- 1 RECOIL BUFFER (1) AND FLAT WASHER (2). Lightly lube with lubricating oil (LSA) (item 16, app D) and place on retainer assembly (3).

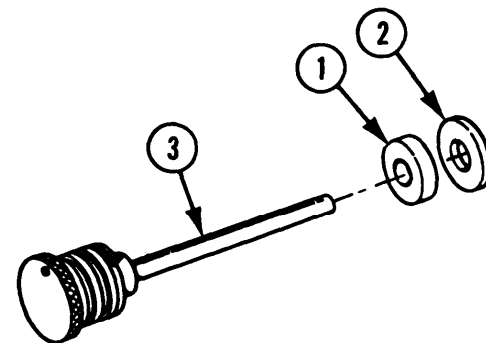

- 2 INNER HELICAL COMPRESSION SPRING (4), MIDDLE HELICAL COMPRESSION SPRING (5), AND OUTER HELICAL COMPRESSION SPRING (6). Lightly lube with lubricating oil (LSA) (item 16, app D) and place on retainer assembly (3).

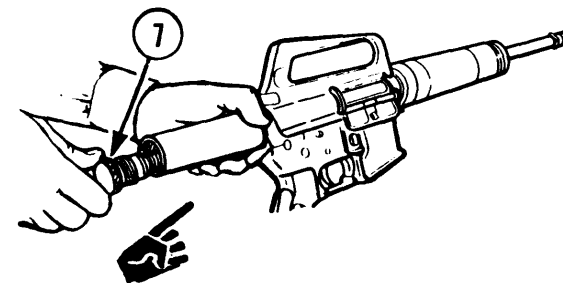
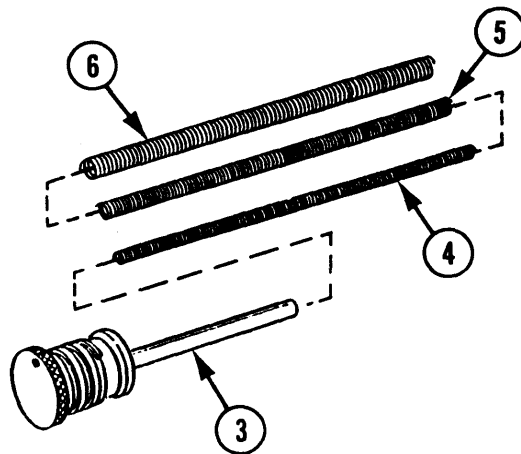

- 3 DRIVE SPRING AND GUIDE ASSEMBLY (7). Install and turn clockwise to lock in place.

## 2-10. RETAINER ASSEMBLY--MAINTENANCE INSTRUCTIONS

### THIS TASK COVERS:

- |                |               |
|----------------|---------------|
| a. Disassembly | d. Repair     |
| b. Cleaning    | e. Reassembly |
| c. Inspection  |               |

### INITIAL SETUP

#### Tools and Special Tools

Small arms repairman tool kit (SC 5180-95-CL-A07)

#### Materials/Parts

Lubricating oil (LSA) (item 16, app D)

Wiping rag (item 18, app D)

#### Personnel Required

MOS 76Y-10 Supply clerk/unit armorer

#### References

Appendix C

Appendix D

#### Equipment Conditions

2-19 Retainer assembly removed

## DISASSEMBLY

### WARNING

Be careful when removing spring loaded parts. Carelessness could result in injury.

### NOTE

Catch small parts as they fall to prevent loss.

- 1 SPRING PIN (1). Remove from spring retainer (2) using 1/16-inch punch (3).
- 2 HELICAL COMPRESSION SPRING (4) AND SAFETY DETENT (5). Remove.

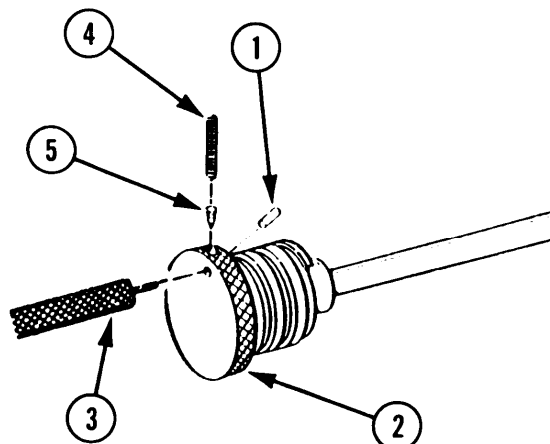

## CLEANING

ALL PARTS. Wipe with wiping rag (item 18, app D).

## INSPECTION

1 SPRING RETAINER (1) AND RETAINER ROD (2).

- a. Inspect for deformation. If defective, notify direct support maintenance.
- b. Inspect for burrs. If present, remove with a stone.

2 SPRING PIN (3), HELICAL COMPRESSION SPRING (4), AND SAFETY DETENT (5). Inspect for bends and deformation. If damaged, replace.

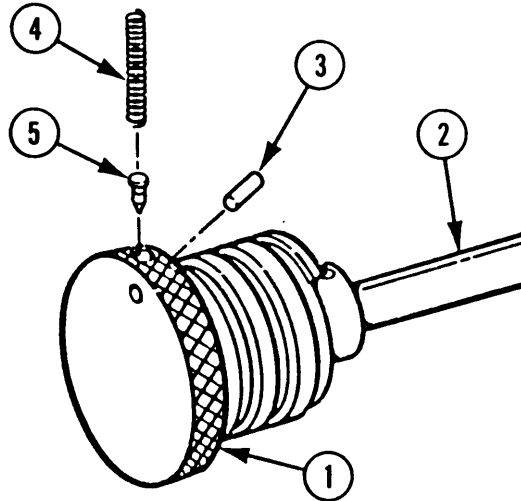

## REPAIR

Repair is by replacement of authorized parts (app C) as required.

## REASSEMBLY

1 SPRING PIN (1). Start spring pin (1) in spring retainer (2).

2 SAFETY DETENT (3) AND HELICAL COMPRESSION SPRING (4).

- a. Generously lube with lubricating oil (LSA) (item 16, app D).

### NOTE

Install pointed end of the safety detent first.

- b. Insert in spring retainer (2).

3 SPRING PIN (1). While depressing helical compression spring (4), drive spring pin (1) in.

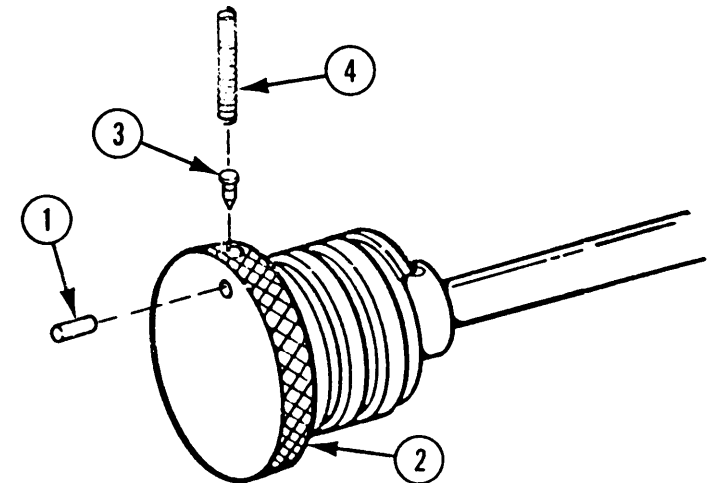

---

2-11. BOLT CARRIER AND STRIKER ASSEMBLY--MAINTENANCE INSTRUCTIONS

---

THIS TASK COVERS:

- |                |               |
|----------------|---------------|
| a. Disassembly | d. Repair     |
| b. Cleaning    | e. Reassembly |
| c. Inspection  |               |

INITIAL SETUP

Tools and Special Tools  
Key tool (C-11, app C)  
Small arms cleaning brush (11686340)  
Small arms repairman tool kit (SC 5180-95-CL-A07)

Equipment Conditions  
2-15 Bolt carrier and striker assembly removed

General Safety Instructions

Materials/Parts  
Rifle bore cleaning compound (RBC) (item 8, app D)  
Small arms cleaning swab (item 20, app D)  
Tobacco pipe cleaner (item 7, app D)

**WARNING**  
To avoid possible explosion, never exchange or switch bolt carrier and striker assembly from one weapon to another.

Personnel Required  
MOS 76Y-10 Supply clerk/unit armorer

References  
Appendix C  
Appendix D  
TM 9-1005-309-10

## DISASSEMBLY

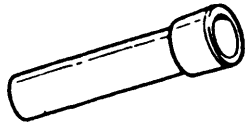

### NOTE

The firing hammer was removed when the M231 submachine gun was disassembled (p 2-15).

- 1 FIRING PIN RETAINING PIN (1). Remove from bolt carrier and key assembly (2) using a 1/16-inch punch.
- 2 FIRING PIN (3). Remove by tipping bolt carrier and key assembly (2).

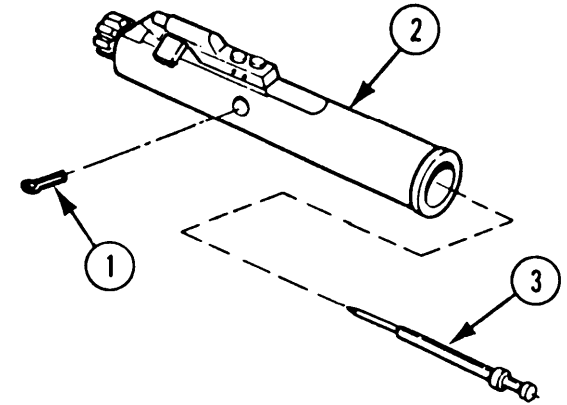

## CLEANING

### NOTE

Make sure breech bolt is pushed into bolt carrier and key assembly before removing bolt cam pin.

- 3 BOLT CAM PIN (4). Rotate 1/4 turn and lift straight up and out of bolt carrier and key assembly (2).
- 4 BREECH BOLT (5). Pull straight out from bolt carrier and key assembly (2) to remove.

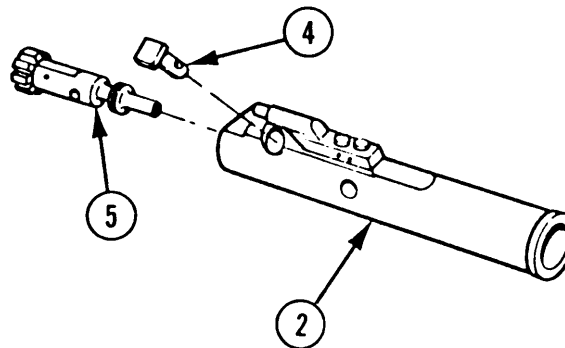

- 1 ALL PARTS. Clean external surfaces with small arms cleaning swab (item 20, app D) saturated with rifle bore cleaning compound (RBC) (item 8, app D).
- 2 BOLT CARRIER KEY.
  - a. Clean inside with small arms cleaning brush dipped in rifle bore cleaning compound (RBC) (item 8, app D).
  - b. Dry with tobacco pipe cleaner (item 7, app D).

## 2-11. BOLT CARRIER AND STRIKER ASSEMBLY--MAINTENANCE INSTRUCTIONS (cont)

## INSPECTION

- 1 FIRING PIN. Inspect point for large chips or pits. Point should be smooth and even. If defective, notify direct support maintenance.
- 2 ALL PARTS.
  - a. Inspect for cracks, corrosion, or other defects. If defective, notify direct support maintenance.
  - b. Inspect for burrs, remove with a stone if present.

## REPAIR

**CAUTION**

Be careful during the following procedure to ensure that the striking force is not directed to the attaching screws and that the tube portion, is not enlarged or flared beyond original requirements. Such enlargement would permit loss of gas pressure when the key and gas metallic bent tube come together during functioning.

- 1 BOLT CARRIER AND KEY ASSEMBLY (1). Repair small dents and/or distortions with the key tool as follows:
  - a. Place the bolt carrier and key assembly on the edge of a table as shown.
  - b. Insert the small end of the key tool (2) into the tube portion of the key (3).
  - c. Strike the large end of the key tool (lightly) with a 3-ounce soft brass hammer (4).
  - d. Repeat striking (gently) until the key is in its original shape. If the key is flared too large or is distorted, notify direct support maintenance.

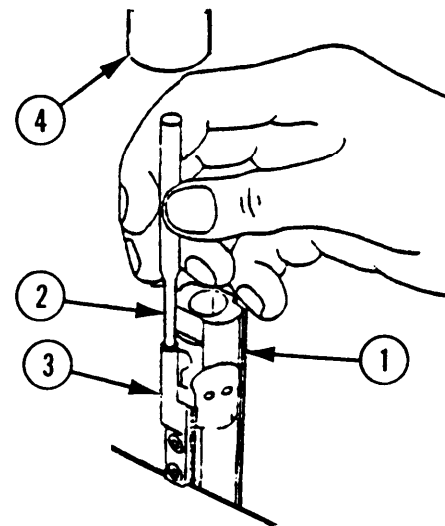

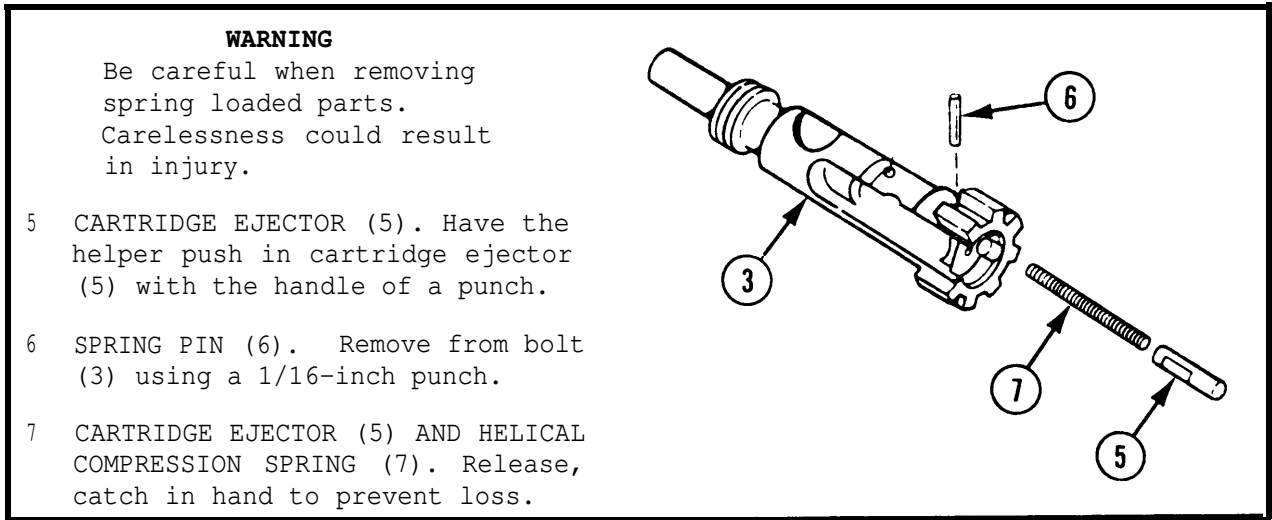
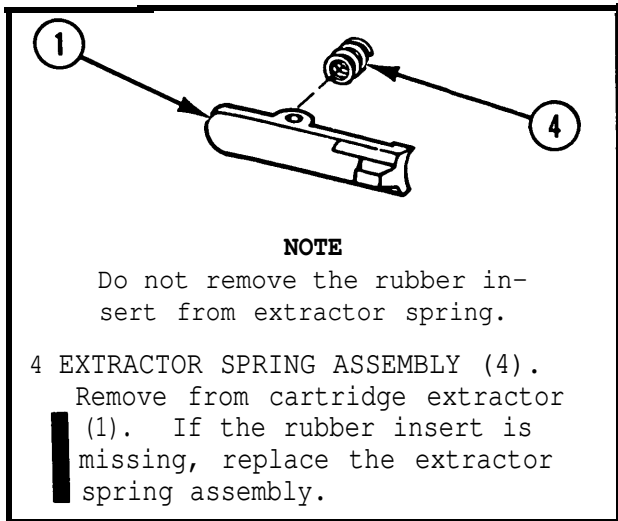

**CLEANING**

1 BOLT.

- Scrub locking lugs with small arms cleaning brush dipped in rifle bore cleaning compound (RBC) (item 8, app D).
- Clean cartridge ejector hole in bolt face using rifle bore cleaning compound (RBC) (item 8, app D) and tobacco pipe cleaner (item 7, app D).
- Clean external surfaces with small arms cleaning swab (item 20, app D) saturated with rifle bore cleaning compound (RBC) (item 8, app D).

2 CARTRIDGE EXTRACTOR, CARTRIDGE EJECTOR, AND HELICAL COMPRESSION SPRING. Clean with small arms cleaning brush dipped in rifle bore cleaning compound (RBC) (item 8, app D).

**INSPECTION**

1 BOLT.

- Inspect exterior surface for large pits or clusters of pits.

**NOTE**  
If cracks are found on breech bolt locking lugs (1) or around cam pin hole (2), notify direct support maintenance.

- Inspect for cracks in the locking lugs (1), especially at the base.
- Inspect for cracks around cam pinhole (2).

## 2-12. BREECH BOLT--MAINTENANCE INSTRUCTIONS (cont)

## INSPECTION (cont)

## 1 BOLT. (cont)

- d. Inspect bolt rings for damage and wear. To check for wear, insert breech bolt in bolt carrier and key assembly and hold with breech bolt end down. If breech bolt falls out, bolt rings are worn. Notify direct support maintenance.

## 2 ALL PARTS.

- a. Inspect for cracks, burrs, kinks, and breaks.  
b. If burrs are present, remove with a stone.

## REPAIR

Repair is by replacement of authorized parts (app C) as required.

## REASSEMBLY

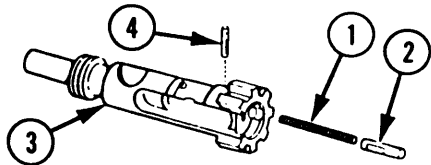

- 1 HELICAL COMPRESSION SPRING (1) AND CARTRIDGE EJECTOR (2). Apply lubricating oil (ISA) (item 16, app D), insert in bolt (3) and have helper push in to hold in place while aligning notch in cartridge ejector with hole in breech bolt.

- 2 SPRING PIN (4). Drive into bolt (3).

- 3 EXTRACTOR SPRING ASSEMBLY (5). Press into cartridge extractor (6), large end first, until it snaps in place and is retained.
- 4 CARTRIDGE EXTRACTOR (6). Position in place on bolt (3). Press to hold in place.
- 5 EXTRACTOR PIN (7). Install.

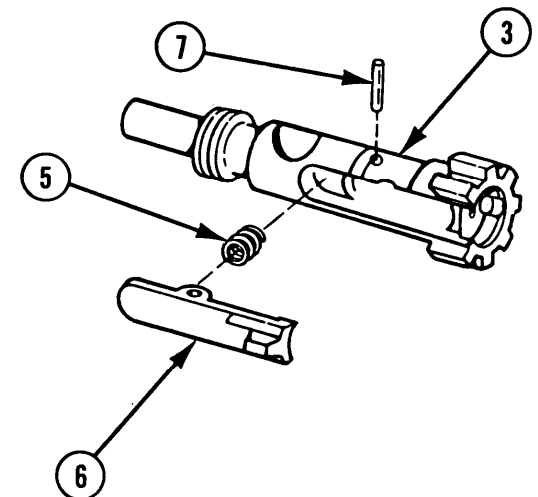

## 2-13. UPPER RECEIVER AND BARREL ASSEMBLY--MAINTENANCE INSTRUCTIONS

### THIS TASK COVERS:

- a. Disassembly
- b. Inspection
- c. Repair
- d. Reassembly

### INITIAL SETUP

#### Tools and Special Tools

Small arms repairman tool kit (SC 5180-95-CL-A07)

#### Personnel Required

MOS 76Y-10 Supply clerk/unit armorer  
Helper

#### References

Appendix C

#### Equipment Conditions

2-15 Upper receiver and barrel assembly removed

### DISASSEMBLY

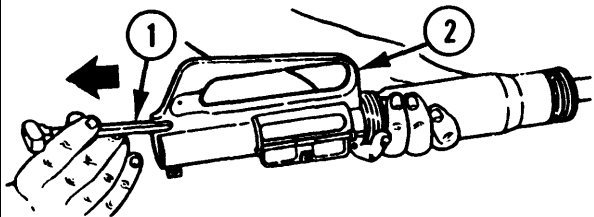

#### 1 CHARGING HANDLE ASSEMBLY (1).

- a. Pull to the rear.
- b. Align detents with slots in upper receiver assembly.
- c. Pull down and remove from upper receiver assembly (2).

#### NOTE

Two soldiers may be required to remove handguards.

#### 2 TWO HANDGUARDS (3).

- a. Point barrel upward and have helper push down on barrel nut assembly (4).
- b. Armorer pivots each handguard (3) outward to remove.

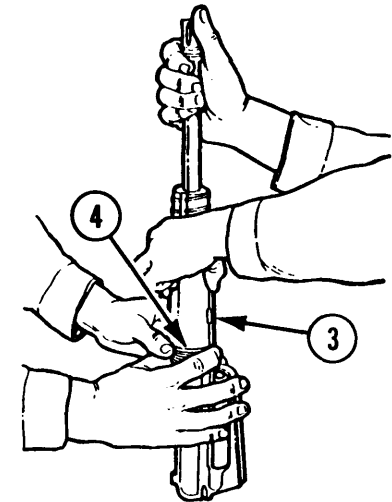

---

 2-13. UPPER RECEIVER AND BARREL ASSEMBLY--MAINTENANCE INSTRUCTIONS (cont)
 

---

**INSPECTION**

## 1 TWO HANDGUARDS .

**NOTE**

Handguard can have cracks up to 1 in. (2.54 cm) long. If cracks are longer than 1 in. (2.54 cm), replace handguard.

- a. Inspect for cracks or loose rivets allowing liner to rattle.
- b. Inspect for broken vent tabs. If two or more tabs are missing from either handguard, the handguard is unserviceable.

## 2 ALL PARTS.

- a. Inspect for cracks, deformation, and proper functioning. If defective, notify direct support maintenance.
- b. Inspect for burrs, remove with stone if present.

**REPAIR**

Repair is by replacement of authorized parts (app C) as required.

**NOTE**

For repair of the charging handle assembly, refer to page 2-33. For repair of the upper receiver assembly, refer to page 2-35.

**REASSEMBLY**
**NOTE**

Two soldiers may be required to install handguards.

## 1 TWO HANDGUARDS (1).

- a. Point barrel and extension assembly upward and have helper pull down on barrel nut assembly (2).
- b. Armorer inserts top of each handguard (1) into upper barrel collar (3) and pivots handguard downward against barrel and extension assembly.
- c. Release barrel nut assembly (2).

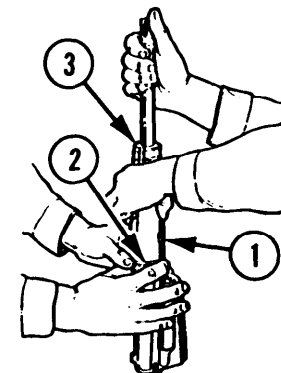

2 CHARGING HANDLE ASSEMBLY (4).

- a. Aline detents on charging handle assembly (4) with slots in upper receiver assembly (5).
- b. Lift up and push charging handle assembly forward to install

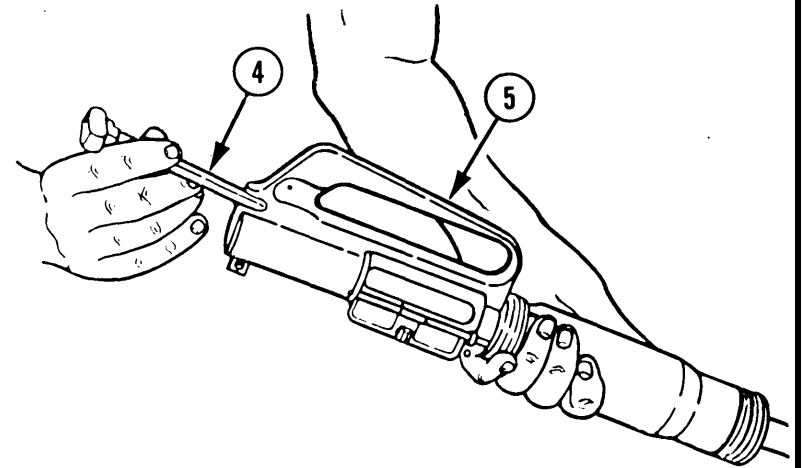

2-14. CHARGING HANDLE ASSEMBLY--MAINTENANCE INSTRUCTIONS

THIS TASK COVERS:

- |                |                 |
|----------------|-----------------|
| a. Removal     | d. Repair       |
| b. Disassembly | e. Reassembly   |
| c. Inspection  | f. Installation |

INITIAL SETUP

Tools and Special Tools  
Small arms repairman tool kit (SC 5180-95-CL-A07)

References  
Appendix C

Personnel Required  
MOS 76Y-10 Supply clerk/unit armorer

## 2-14. CHARGING HANDLE ASSEMBLY--MAINTENANCE INSTRUCTIONS (cont)

## REMOVAL

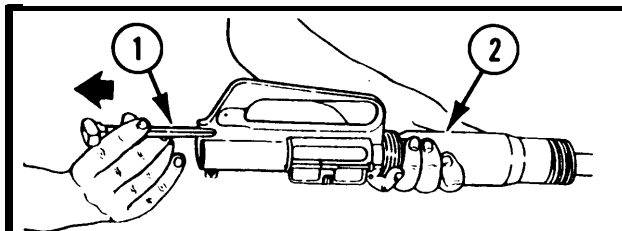

CHARGING HANDLE ASSEMBLY (1). Pull charging handle assembly to the rear. Align charging handle assembly detents with slots in upper receiver assembly. Pull down and remove from upper receiver assembly (2).

## DISASSEMBLY

## WARNING

Be careful when removing spring loaded parts. Carelessness could result in injury.

- 1 SPRING PIN (1). Remove from charging handle (2) using 1/16-inch punch.

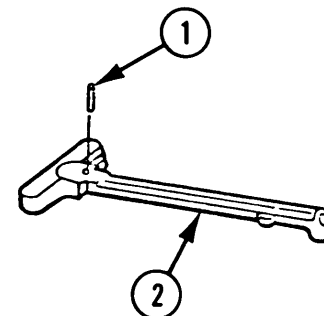

## INSPECTION

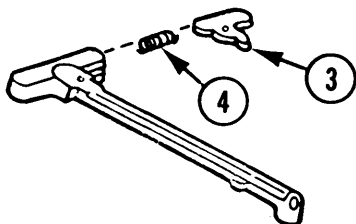

NOTE  
Catch small parts to prevent loss.

- 2 CHARGING HANDLE LATCH (3) AND HELICAL COMPRESSION SPRING (4). Remove.

## REPAIR

- 1 CHARGING HANDLE. check for damage or breaks. If defective, replace charging handle assembly.
- 2 ALL PARTS.
  - a. Inspect for weak spring tension, cracks, burrs, or corrosion.
  - b. If burrs are present, remove with a stone.

Repair is by replacement of authorized parts (app C) as required.

## REASSEMBLY

1 HELICAL COMPRESSION SPRING (1)  
AND CHARGING HANDLE LATCH (2).

- a. Insert into charging handle (3).
- b. Press in on charging handle latch (2) and align holes. Use 1/16-inch punch to hold in place.

2 SPRING PIN (4). Install by driving punch out.

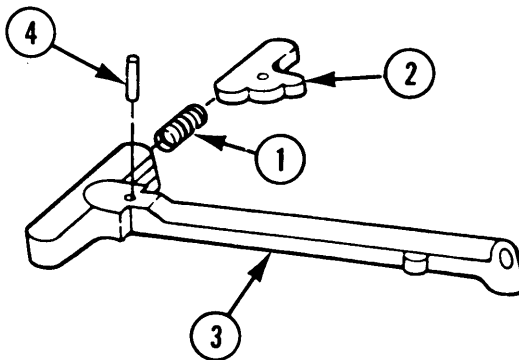

## INSTALLATION

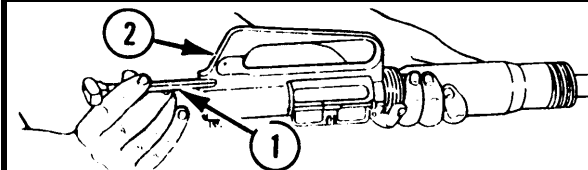

CHARGING HANDLE ASSEMBLY (1).

- a. Align detents on charging handle assembly (1) with slots in upper receiver assembly (2).
- b. Lift up and push charging handle assembly forward to install.

## 2-15. UPPER RECEIVER ASSEMBLY--MAINTENANCE INSTRUCTIONS

### THIS TASK COVERS:

- a. Disassembly
- b. Cleaning
- c. Inspection
- d. Repair
- e. Reassembly

### INITIAL SETUP

#### Tools and Special Tools

Small arms repairman tool kit (SC 5180 95-CL-A07)

#### Materials/Parts

Abrasive cloth (item 9, app D)  
Artist's brush (item 5, app D)  
Dry cleaning solvent (item 10, app D)  
Protective gloves (item 10.1, app D)  
Rifle bore cleaning compound (RBC) (item 8, app D)  
Solid film lubricant (item 13, app D)  
Tools and, parts cleaning brush (item 6, app D)

#### Personnel Required

MOS 76Y-10 Supply clerk/unit armorer

#### References

Appendix C  
Appendix D

#### Equipment Conditions

2-15 Upper receiver and barrel assembly removed

## 2-15. UPPER RECEIVER ASSEMBLY--MAINTENANCE INSTRUCTIONS (cont)

## DISASSEMBLY

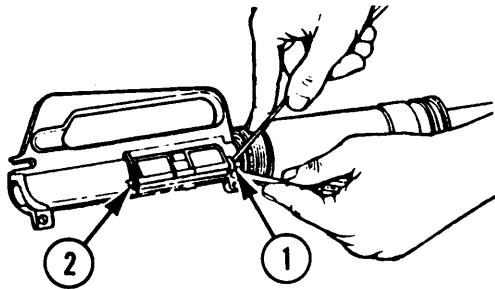

1 RETAINING RING (1). Use two small screwdrivers as shown to remove retaining ring (1) from ejection port cover pin (2).

**WARNING**  
Be careful when removing spring loaded parts. Carelessness could result in injury.

- 2 EJECTION PORT COVER PIN (2). Pull out of upper receiver (3).
- 3 HELICAL TORSION SPRING (4) AND EJECTION PORT COVER (5). Remove.

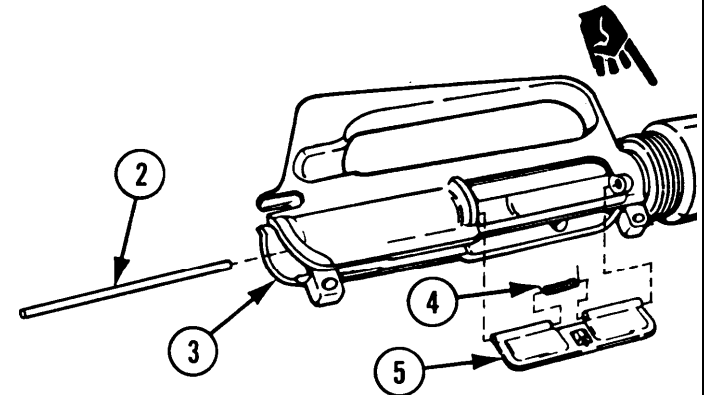

## CLEANING

## ALL PARTS.

- a. Remove carbon using rifle bore cleaning compound (RBC) (item 8, app D).
- b. Clean corroded areas with abrasive cloth (item 9, app D).

**WARNING**

■ Dry cleaning solvent (SD) (A-A-711) is flammable and should not be used near an open flame or in a smoking area. Use only in well-ventilated areas. This solvent evaporates quickly and has a drying effect on the skin. Use of gloves (item 10.1, app D) is necessary to protect the skin. When used without gloves it may cause cracks in the skin and in some cases mild irritation or inflammation.

c. Clean with dry cleaning solvent (item 10, app D) using artist's brush (item 5, app D) and tools and parts cleaning brush (item 6, app D).

## INSPECTION

ALL PARTS.

- a. Inspect for cracks, burrs, corrosion, or other defects.
- b. If present, remove burrs with a stone.

## REPAIR

1 UPPER RECEIVER.

- a. Inspect for missing protective finish.

### CAUTION

Do not use wire brush to roughen surface.

- b. Roughen surface with abrasive cloth (item 9, app D).

### WARNING

When using solid film lubricant, be sure area is well-ventilated.

Dry cleaning solvent (SD) (A-A-711) is flammable and should not be used near an open flare or in a smoking area. Use only in well-ventilated areas. This solvent evaporates quickly and has a drying effect on the skin. Use of gloves (item 10.1, app D) is necessary to protect the skin. When used without gloves it may cause cracks in the skin and in some cases mild irritation or inflammation.

### CAUTION

Solid film lubricant is to be used only as an exterior surface protective finish and touchup. If the solid film lubricant comes in contact with recoiling parts or functional surfaces of the M231 submachine gun, remove immediately by cleaning with dry cleaning solvent (item 10, app D).

Be sure upper receiver is thoroughly cleaned and dried prior to application of solid film lubricant.

- c. Apply solid film lubricant (item 13, app D) to all shiny exterior surfaces. Allow 24 hours to dry before reassembly.

2 ALL PARTS. Repair is by replacement of authorized parts (app C) as required.

## 2-15. UPPER RECEIVER ASSEMBLY--MAINTENANCE INSTRUCTIONS (cont)

REASSEMBLY

- 1 EJECTION PORT COVER (1). Position on upper receiver (2) and hold in place.
- 2 EJECTION PORT COVER PIN (3). Install through upper receiver (2) and ejection port cover (1) up to spring opening.
- 3 HELICAL TORSION SPRING (4). Put in place with long end toward the front of the upper receiver.
- 4 EJECTION PORT COVER PIN (3). Insert halfway into helical torsion spring (4).
- 5 HELICAL TORSION SPRING (4). Twist long end of spring one full turn to the right.
- 6 EJECTION PORT COVER PIN (3). Insert all the way and release helical torsion spring (4).
- 7 RETAINING RING (5). Install on ejection port cover pin (3) using small screwdriver.

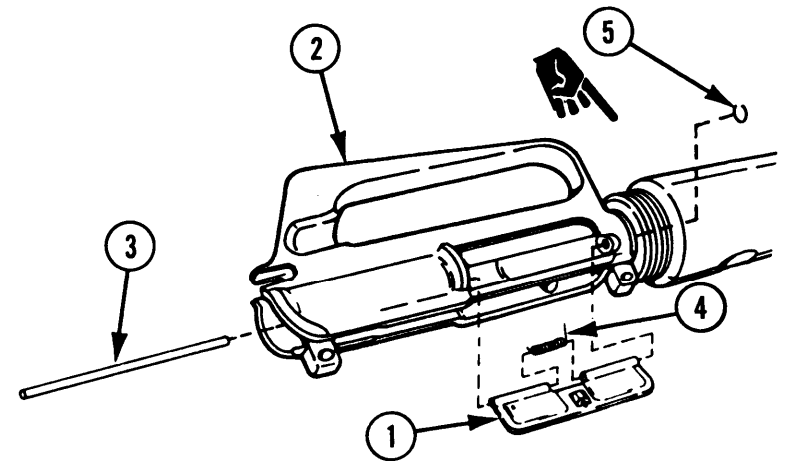

## 2-16. LOWER RECEIVER AND RECEIVER EXTENSION ASSEMBLY--MAINTENANCE INSTRUCTIONS

## THIS TASK COVERS:

- |  |  |
|--|--|
| <ol style="list-style-type: none"> <li>a. Disassembly</li> <li>b. Cleaning</li> <li>c. Inspection</li> </ol> | <ol style="list-style-type: none"> <li>d. Repair</li> <li>e. Reassembly</li> </ol> |
|--|--|

## INITIAL SETUP

Tools and Special Tools  
Pivot pin removing tool (fig. 2, app E)

Small arms cleaning brush (11686340)  
Small arms repairman tool kit (SC 5180-95-CL-A07)

#### Materials/Parts

- Abrasive cloth (item 9, app D)
- Artist's brush (item 5, app D)
- Dry cleaning solvent (item 10, app D)
- Lubricating oil (LSA) (item 16, app D)
- Protective gloves (item 10.1, app D)
- Rifle bore cleaning compound (RBC) (item 8, app D)
- Solid film lubricant (item 13, app D)
- Tools and parts cleaning brush (item 6, app D)

#### Personnel Required

MOS 76Y-10 Supply clerk/unit armorer

#### References

- Appendix C
- Appendix D
- TM 9-1005-309-10

#### Equipment Conditions

- 2-15 Lower receiver and receiver extension assembly removed

### DISASSEMBLY

#### WARNING

Be careful when removing spring loaded parts. Carelessness could result in injury.

#### 1 PIVOT PIN (1).

- a. Insert fabricated pivot pin removing tool (2) in groove of pivot pin (1) to compress takedown pin detent (3).

#### NOTE

Catch small parts to prevent loss.

- t). Turn pivot pin 1/4 turn and remove pivot pin removing tool and pivot pin from lower receiver (4).

- #### 2 TAKEDOWN PIN DETENT (3) AND HELICAL COMPRESSION SPRING (5). Remove.

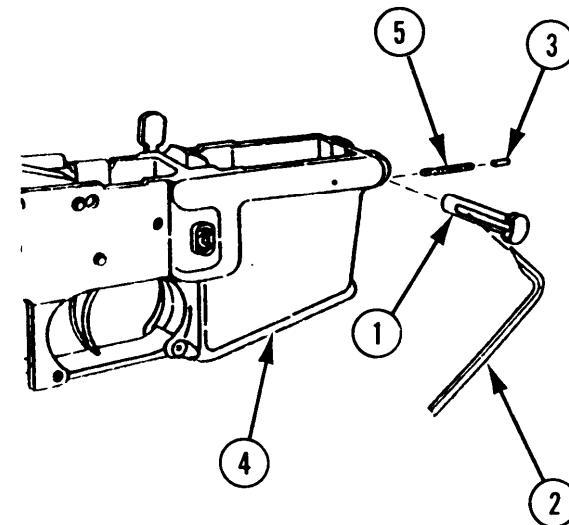

## 2-16. LOWER RECEIVER AND RECEIVER EXTENSION ASSEMBLY--MAINTENANCE INSTRUCTIONS (cont)

## DISASSEMBLY (cont)

3 MACHINE SCREW (6), LOCKWASHER (7), AND RIFLE GRIP (8). Remove from lower receiver (4).

**NOTE**

Catch small parts to prevent loss.

4 HELICAL COMPRESSION SPRING (9) AND SAFETY DETENT (10). Remove.

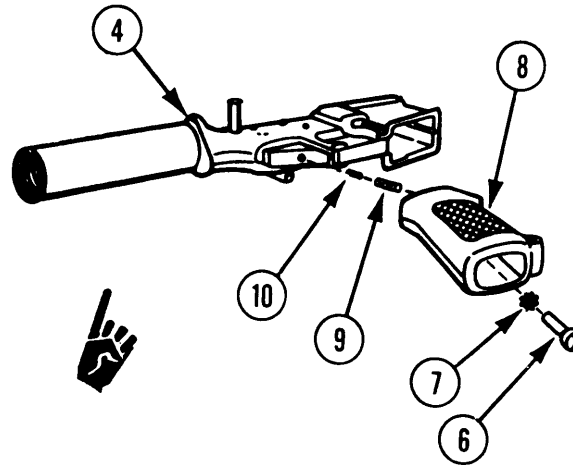

## CLEANING

1 LOWER RECEIVER.

- a. Clean using small arms cleaning brush dipped in rifle bore cleaning compound (RBC) (item 8, app D).
- b. Remove corrosion with abrasive cloth (item 9, app D).

**WARNING**

Dry cleaning solvent (SD) (A-A-711) is flammable and should not be used near an open flame or in a sinking area. Use only in well-ventilated areas. This solvent evaporates quickly and has a drying effect on the skin. Use of gloves (item 10.1, app D) is necessary to protect the skin. When used without gloves it may cause cracks in the skin and in some cases mild irritation or inflammation.

- c. Clean thoroughly with dry cleaning solvent (item 10, app D) using artist's brush (item 5, app D) and tools and parts cleaning brush (item 6, app D).
- d. Lightly lubricate with lubricating oil (LSA) (item 16, app D).

2 ALL REMAINING PARTS.

- a. Clean using small arms cleaning brush dipped in rifle bore cleaning compound (RBC) (item 8, app D).
- b. Generously lubricate all internal parts with lubricating oil (LSA) (item 16, app D).

## INSPECTION

ALL PARTS.

- a. Inspect for cracks, breaks, burrs, or corrosion.
- b. If present, remove burrs with stone.

## REPAIR

1 LOWER RECEIVER.

- a. Inspect for missing protective finish.

### CAUTION

Do not use wire brush to roughen surface.

- b. Roughen surface with abrasive cloth (item 9, app D).

### WARNING

When using solid film lubricant, be sure area is well-ventilated.

### WARNING

Dry cleaning solvent (SD) (A-A-711) is flammable and should not be used near an open flare or in a sinking area. Use only in well-ventilated areas. This solvent evaporates quickly and has a drying effect on the skin. Use of gloves (item 10.1, app D) is necessary to protect the skin. When used without gloves it may cause cracks in the skin and in some cases mild irritation or inflammation.

### CAUTION

Solid film lubricant is to be used only as an exterior surface protective finish and touchup. IS solid film lubricant comes in contact with recoiling parts or functional surfaces of the M231 submachine gun, remove immediately by cleaning with dry cleaning solvent (item 10, app D).

Be sure lower receiver is thoroughly cleaned and dried prior to application of solid film lubricant.

### NOTE

If one-third or more of the exterior protective finish is missing, notify direct support maintenance.

- c. Apply solid film lubricant (item, app D) to all n shiny exterior surfaces. Allow to dry 24 hours before reassembly.
- 2 ALL PARTS. Repair is, by replacement of authorized parts (app C) as required.

## REASSEMBLY

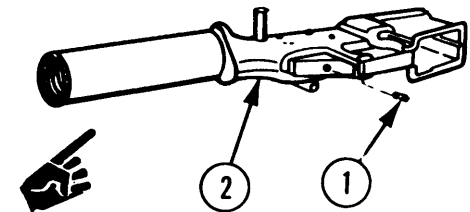

1 SAFETY DETENT (1).

- a. Lightly lube with lubricating oil (LSA) (item 16, app D).
- b. Insert in lower receiver (2) with pointed end first.

## 2-16. LOWER RECEIVER AND RECEIVER EXTENSION ASSEMBLY--MAINTENANCE INSTRUCTIONS (cont)

## REASSEMBLY (cont)

**WARNING**

When utilizing the enhanced rifle grip (has a bump between the second and third finger for a better grip) PN 9349127, rifle grip screw, PN AN501D416-18 (1-1/8 in.) or AN501D416-16 (1 in.) are the authorized screws to be used with the enhanced grip. Any screw longer than 1-1/8 in. used with 9349127 could cause a hazardous situation. Also, ensure the washer is in place.

- 2 LOCKWASHER (3) AND MACHINE SCREW (4).  
Install in rifle grip (5).

**NOTE**

Turn rifle grip sideways for ease in installation.

- 3 HELICAL COMPRESSION SPRING (6).  
a. Install in rifle grip (5).  
b. Aline with lower receiver (2).

**CAUTION**

Be careful not to damage helical compression spring.

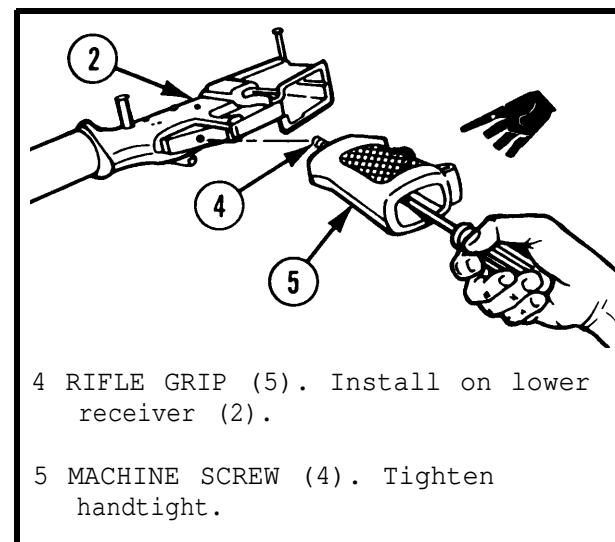
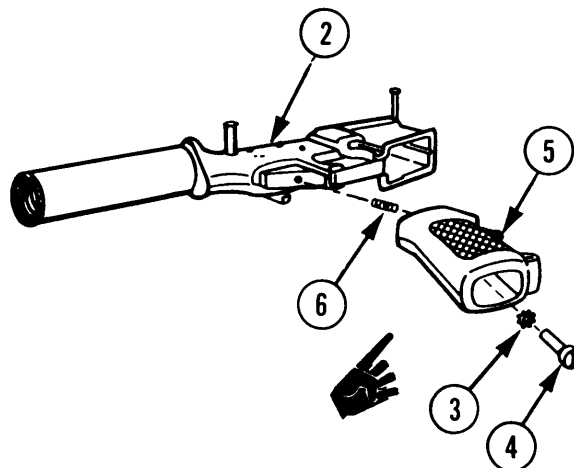

REASSEMBLY (cont)

6 HELICAL COMPRESSION SPRING (7) AND TAKEDOWN PIN DETENT (8).

- a. Lightly lube helical compression spring (7) with lubricating oil (LSA) (item 16, app D) and install in lower receiver (2).
- b. Position takedown pin detent (8) on helical compression spring (7) with needle nose pliers.
- c. Hold lower receiver (2) firmly, compress takedown pin detent (8) in recess of lower receiver (2) with needle nose pliers, and install pivot pin (9). Be sure takedown pin detent (8) is in groove of pivot pin (9).

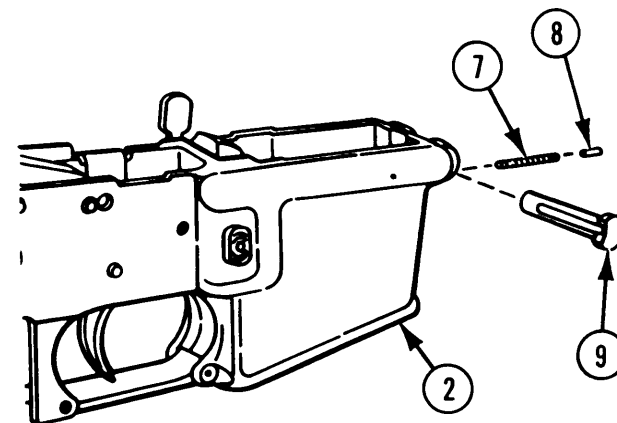



# CHAPTER 3

## DIRECT SUPPORT MAINTENANCE INSTRUCTIONS

### Section I. TROUBLESHOOTING

#### 3-1. TROUBLESHOOTING INFORMATION

a. The symptom index can be used as a quick guide to troubleshooting. Common malfunctions are listed in alphabetical order with a page number reference to the troubleshooting table where a test or inspection and corrective action are provided.

b. The troubleshooting procedures list the malfunction, the test or inspection indicating the malfunction, and the corrective action needed. There are illustrations to show location of parts. This manual cannot list all malfunctions that may occur nor all test or inspections and corrective actions. If a malfunction is not mentioned or is not corrected by specified corrective action, notify your supervisor.

#### SYMPTOM INDEX

	Troubleshooting Procedure (Page)
M231 SUBMACHINE GUN	
Fails to <b>chamber</b> .....	3-3
Fails to eject .....	3-7
Fails to extract .....	3-6
Fails to feed .....	3-2
Fails to fire .....	3-5
Fails to lock .....	3-3
Fails to lock to rear .....	3-8.1
Fails to lock to rear after last round .....	3-8.1
Fails to unlock .....	3-6

## 3-1. TROUBLESHOOTING INFORMATION (cont)

Table 3-1. TROUBLESHOOTING

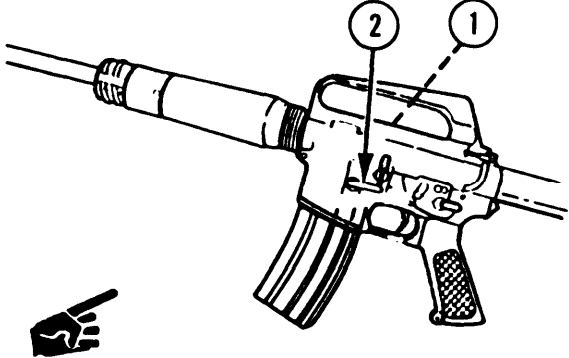
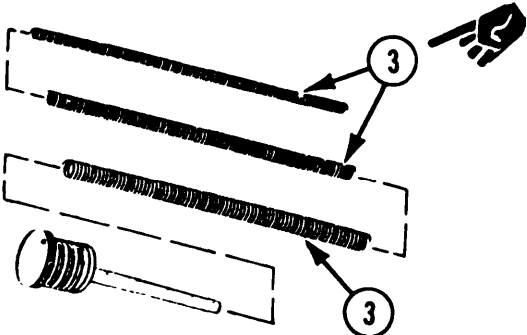
MALFUNCTION TEST OR INSPECTION CORRECTIVE ACTION	LOCATION
<p style="text-align: center;"><b>WARNING</b></p> <p>Before starting any procedures on the M231 submachine gun, be sure to clear weapon.</p> <p>1. FAILS TO FEED).</p> <p>Step 1. Check for defective helical compression spring (1) in magazine catch.</p> <p style="padding-left: 40px;">Replace defective helical compression spring (p 3-45).</p> <p>Step 2. Check to see if magazine catch (2) is worn or broken.</p> <p style="padding-left: 40px;">Replace defective magazine catch (p 3-45).</p> <p>Step 3. Check if magazine catch (2) is out of adjustment.</p> <p style="padding-left: 40px;">Adjust magazine catch. Press magazine catch button (use cleaning rod or a cartridge) until magazine catch (2) protrudes beyond the left side of liner receiver. To tighten, turn magazine catch (2) clockwise. To loosen, turn it counterclockwise.</p>	 <p>The diagram shows a side view of the M231 submachine gun. A hand is pointing to the magazine catch (2) on the left side of the receiver. A dashed line points to the helical compression spring (1) located inside the magazine catch.</p>
<p>Step 4. Check drive spring and guide assembly for broken helical compression springs (3).</p> <p style="padding-left: 40px;">Replace broken helical compression springs (p 3-17).</p>	 <p>The diagram shows a disassembled drive spring and guide assembly. A hand is pointing to the helical compression springs (3) located within the assembly.</p>

2. FAILS TO CHAMBER.

Check to see if helical compression springs (1, 2, and 3) are weak or broken (p 2-19).

Replace defective helical compression springs (p 3-17).

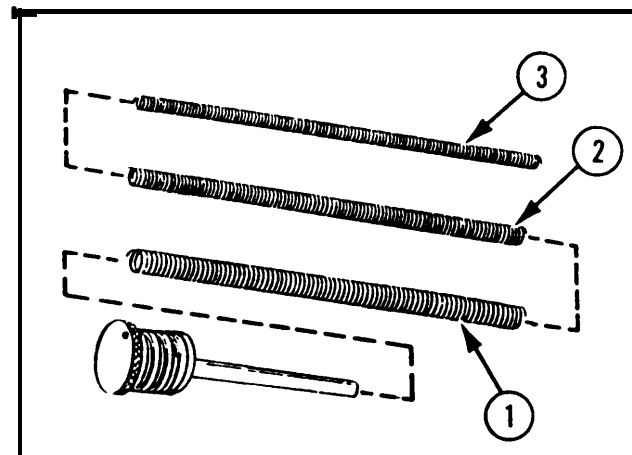

3. FAILS TO LOCK.

Step 1. Check bolt carrier and key assembly (1) to see if key (2) is loose or damaged.

Replace defective bolt carrier and key assembly (p 3-21).

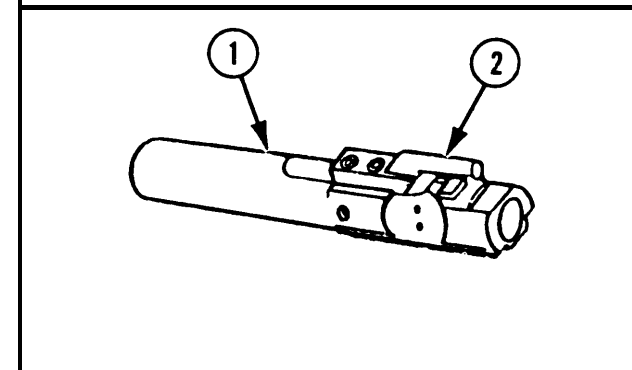

Step 2. Check for defective breech bolt locking lugs (3).

Repair or replace breech bolt (p 3-21).

Step 3. Check for defective mating locking lugs (4) in barrel and extension assembly.

Replace defective barrel and barrel collar assembly (p 3-28).

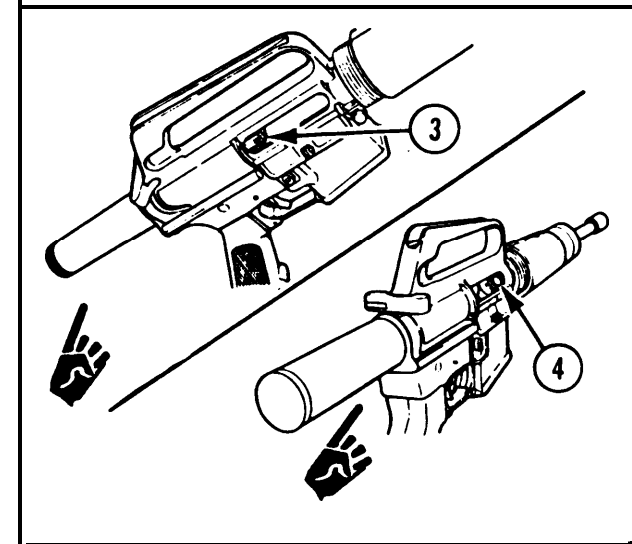

3-1. TROUBLESHOOTING INFORMATION (cont)

Table 3-1. TROUBLESHOOTING (cont)

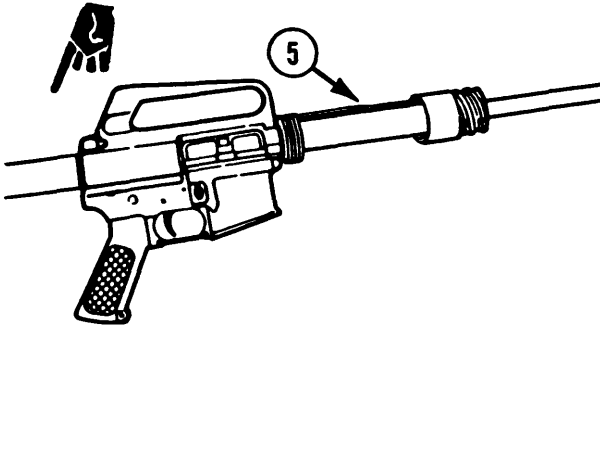
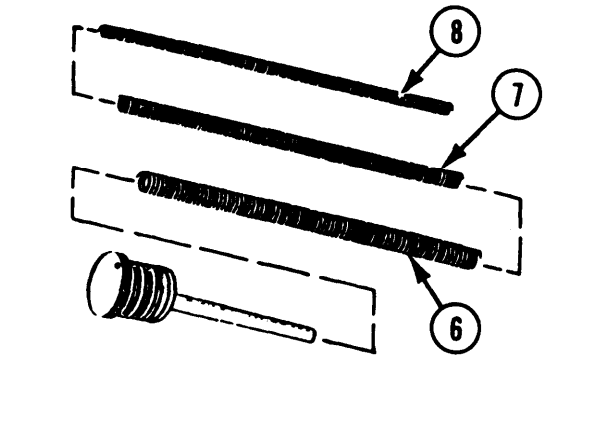
<p>MALFUNCTION TEST OR INSPECTION CORRECTIVE ACTION</p>	<p>LOCATION</p>
<p>3. FAILS TO LOCK. (cont)</p> <p>Step 4. Check gas metallic bent tube (5) for proper alinement or damage.</p> <p>Replace defective gas metallic bent tube and aline properly (p 3-28).</p>	 <p>A line drawing of a handgun with a long gas tube extending from the front. A hand icon with the number 2 is pointing to the handle. A circled number 5 is pointing to the gas metallic bent tube.</p>
<p>Step 5. Check to see if helical compression springs (6, 7, and 8) are weak or broken.</p> <p>Replace defective helical compression springs (p 3-17).</p>	 <p>A diagram showing three helical compression springs labeled 6, 7, and 8. Spring 6 is a small coil at the bottom. Springs 7 and 8 are larger and positioned above it. A bolt is shown to the left of spring 6. Dashed lines indicate the assembly area.</p>

4. FAILS TO FIRE.

Step 1. Check for frozen or broken selector lever (1).

clean or replace defective selector lever (p 3-45).

Step 2. Check to see if trigger (2) or helical torsion spring (3) is defective.

Replace defective parts (p 3-45).

Step 3. Check for chipped point or broken firing pin (4).

Replace defective firing pin (p 3-21).

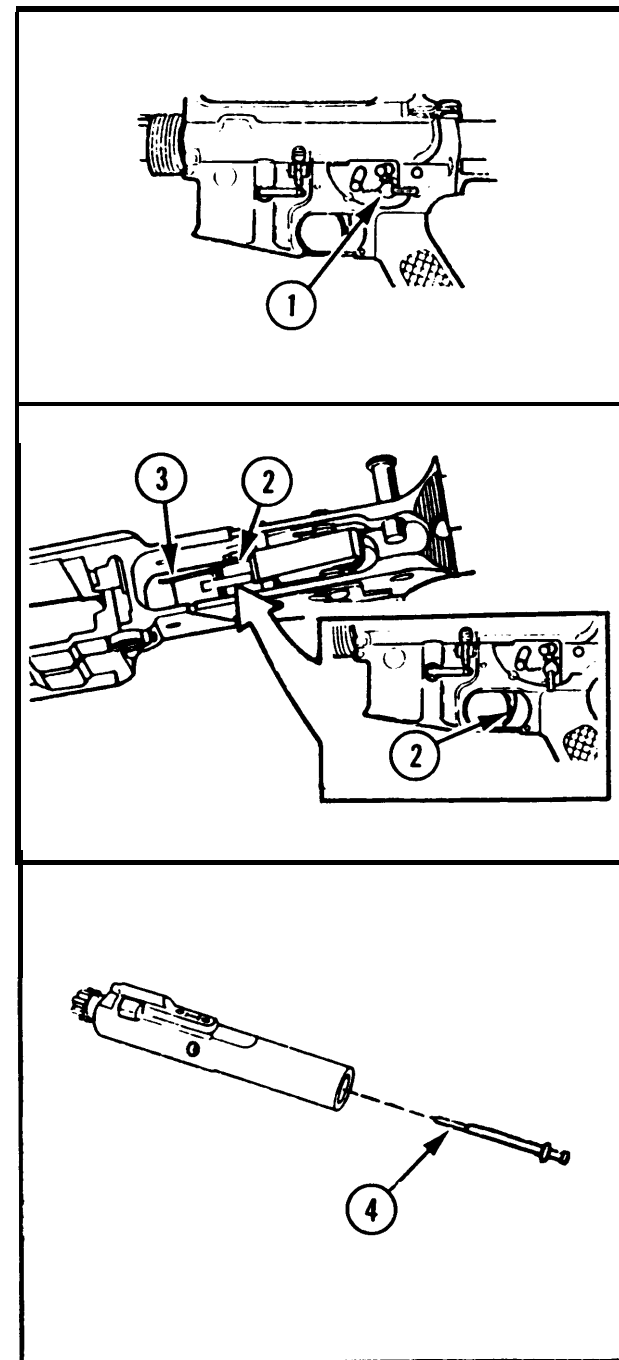

3-1. TROUBLESHOOTING INFORMATION (cont)

Table 3-1. TROUBLESHOOTING (cont)

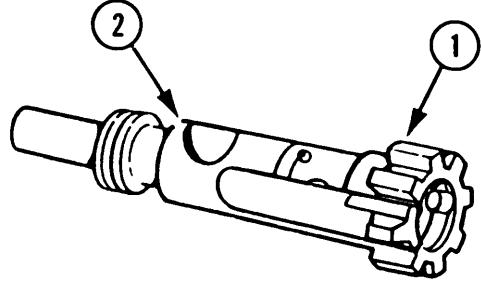
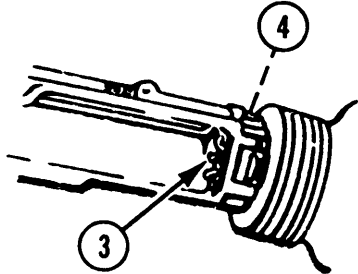
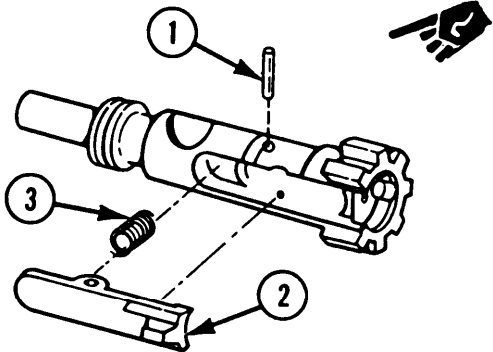
<p>MALFUNCTION TEST OR INSPECTION CORRECTIVE ACTION</p>	<p>LOCATION</p>
<p>5. FAILS UNLOCK.</p> <p>Step 1. Check for burred locking lugs (1) on breech bolt (2).</p> <p>Remove burrs.</p> <p>Step 2. Check for burred locking lugs (3) on barrel and extension assembly (4).</p> <p>Remove burrs.</p>	 
<p>6. FAILS TO EXTRACT.</p> <p>Step 1. Check breech bolt for defective extractor pin (1). cartridge extractor (2), and extractor spring assembly (3).</p> <p>Replace defective parts (p 2-28).</p>	

Step 2. Check barrel and extension assembly (4) to see if chamber is pitted.

Replace barrel and barrel collar assembly (p 3-43), if chamber is pitted.

7. FAILS TO EJECT.

Step 1. Check to see if bolt rings (1) are worn, broken or missing; and that gaps are staggered.

Adjust gap or replace defective bolt rings (p 3-25).

Step 2. Check gas metallic bent tube (2) for proper alinement or damage.

Replace defective gas metallic bent tube and aline properly (p 3-28).

Step 3. Check to see if gas seal (3) is missing from barrel collar (4).

Replace gas seal (p 3-28).

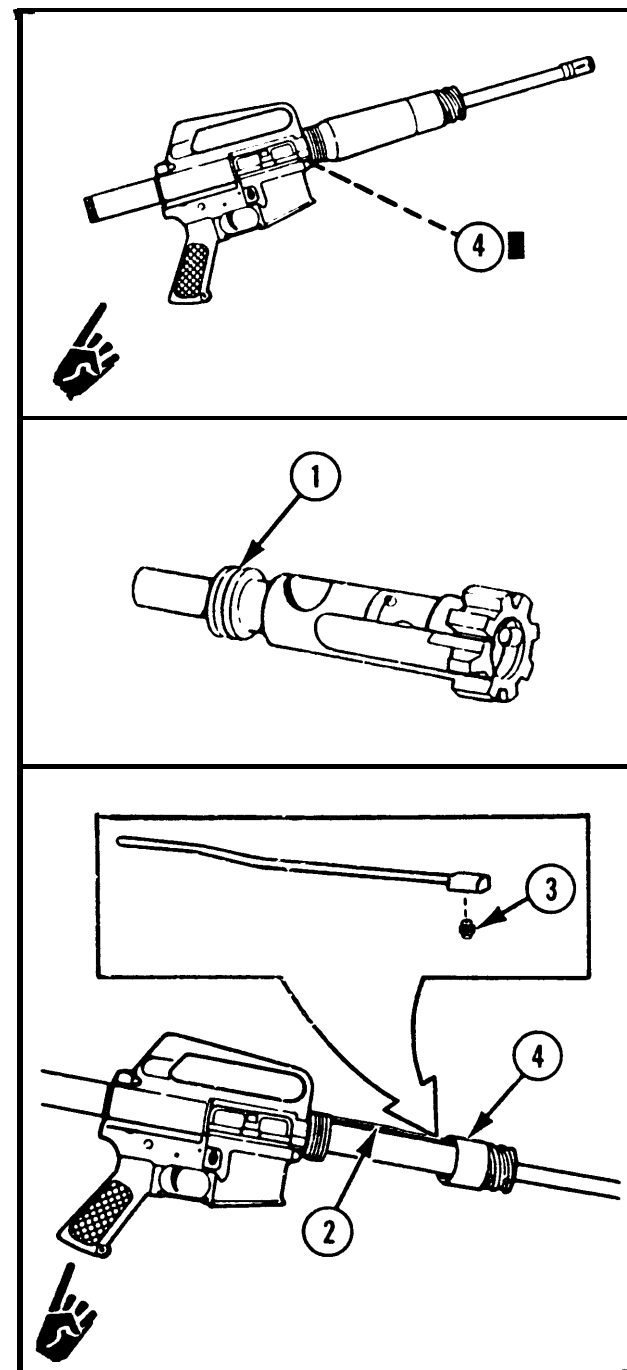

## 3-1. TROUBLESHOOTING INFORMATION (cont)

Table 3-1. TROUBLESHOOTING (cont)

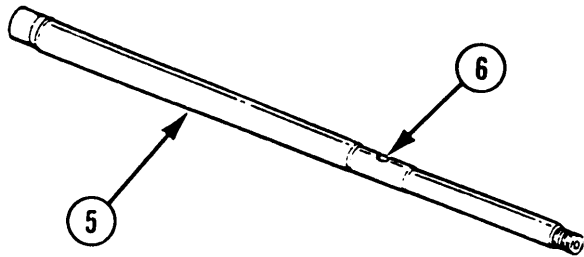
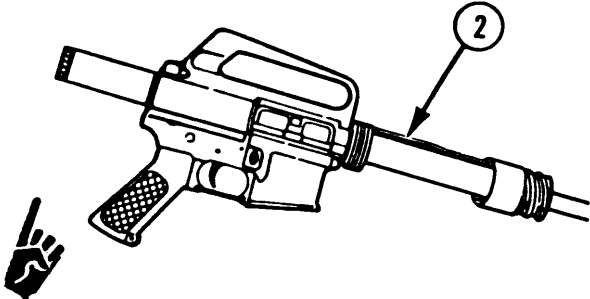
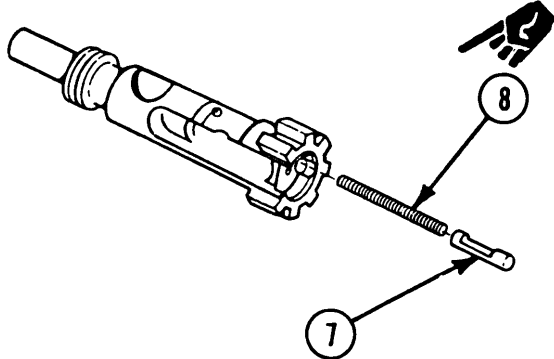
MALFUNCTION TEST OR INSPECTION CORRECTIVE ACTION	LOCATION
<p>7. FAILS TO EJECT. (cont)</p> <p>Step 4. Check barrel and extension assembly (5) for carbon buildup at gas port (6).</p> <p>Remove carbon buildup (p 3-43).</p>	
<p>Step 5. Check to see if gas metallic bent tube (2) is plugged due to carbon buildup.</p> <p>Replace gas metallic bent tube (p 3-28).</p>	
<p>Step 6. Check for frozen cartridge ejector (7).</p> <p>Clean (p 2-28).</p>	
<p>Step 7. Check cartridge ejector (7) for improper installation.</p> <p>Install correctly (p 2-28).</p>	
<p>Step 8. Check for broken cartridge ejector (7).</p> <p>Replace defective cartridge ejector (p 2-28).</p>	
<p>Step 9. Check for broken or weak helical compression spring (8).</p> <p>Replace defective helical compression spring (p 2-28).</p>	

8. FAILS TO LOCK TO REAR.

Step 1. Check for weak or broken helical sear spring (1).

Replace defective helical sear spring (p 3-45).

Step 2. Check to see if sear (2) is worn or broken.

Replace sear (p 3-45).

Step 3. Check to see if helical sear spring (1) is incorrectly assembled.

Remove and install helical sear spring correctly (p 3-45).

Step 4. Deleted.

Step 5. Deleted.

Step 6. Check to see if bolt carrier and key assembly sear notch (3) is worn.

Replace bolt carrier and key assembly (p 3-21).

9. FAILS TO LOCK TO REAR AFTER LAST ROUND.

Step 1. Check for broken bolt catch (1).

Replace defective bolt catch (p 3-45).

Step 2. Check to see if helical compression spring (2) is broken or weak.

Replace defective helical compression spring (p 3-45).

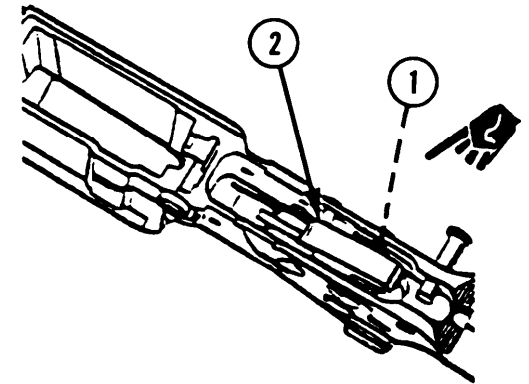

■ Art deleted.

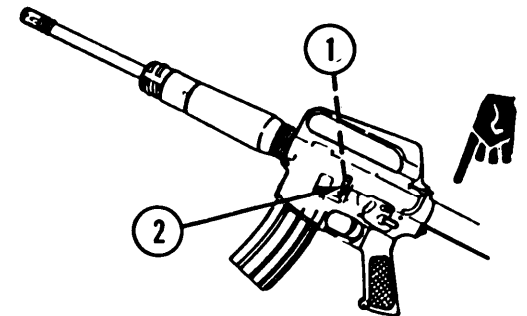
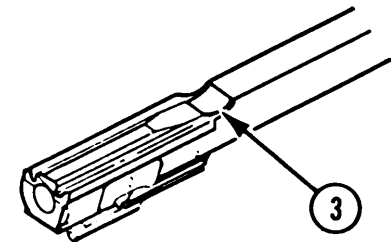



## Section II. MAINTENANCE PROCEDURES

### 3-2. M231 SUBMACHINE GUN--MAINTENANCE INSTRUCTIONS

#### INITIAL SETUP

##### Tools and Special Tools

Key tool (C-11, app C)  
Small arms cleaning brush ( 11686340)  
Small arms repairman tool kit (SC 5180-95-CL-A07)  
Small arms shop set (SC 4933-95-CL-A11)  
Tool and gage set (fig. 11, app C)

Appendix C

Appendix D

Appendix E

TM 9-1005-309-10

##### Materials/Parts

Abrasive cloth (item 9, app D)  
Dry cleaning solvent (item 10, app D)  
Inspection penetrant kit (item 12, app D)  
Lubricating oil (LSA) (item 16, app D)  
Molybdenum disulfide grease (item 11, app D)  
Protective gloves (item 10.1, app D)  
Rifle bore cleaning compound (RBC) (item 8, app D)  
Solid film lubricant (item 13, app D)  
Wiping rag (item 18, app D)

##### Equipment Conditions

3-17 Retainer assembly removed from drive  
spring and guide assembly (task no. 3)  
2-15 Bolt carrier and striker assembly removed  
(tasks no. 4 and 5)  
3-21 Breech bolt removed (task no. 5)  
2-15 Upper receiver and barrel assembly removed  
(tasks no. 6 and 9)  
3-28 Upper receiver assembly removed from upper  
receiver and barrel assembly (task no. 7)  
3-28 Barrel nut assembly removed from upper  
receiver and barrel assembly (task no. 8)  
3-28 Barrel and barrel collar assembly disassembled  
and removed (task no. 9)  
2-15 Lower receiver and receiver extension  
removed (task no. 10)

##### Personnel Required

MOS 45B-10 Small arms repairer  
Helper

##### General Safety Instructions

##### References

3-37 Barrel erosion test  
3-33 Barrel straightness test  
3-32 Chamber test  
3-38 Headspace test  
3-18 Reassembly/installation of drive spring  
and guide assembly  
3-24 Reassembly of bolt carrier and striker  
assembly  
3-33 Reassembly of upper receiver and barrel  
assembly

#### **WARNING**

Before starting any procedures on the M231 submachine gun be sure to clear the weapon. Live ammunition should not be near the work area.

To avoid possible explosion, never exchange or switch bolt carrier and striker assembly from one weapon to another.

---

 3-2. M231 SUBMACHINE GUN--MAINTENANCE INSTRUCTIONS (cont)
 

---

## LIST OF TASKS

Task No.	Task	Task Ref (Page)
1.	Maintain M231 submachine gun: <ul style="list-style-type: none"> <li>a. Inspect.</li> <li>b. Clean.</li> <li>c. Test trigger pull.</li> </ul>	3-13 3-13 3-16
2	Maintain drive spring and guide assembly: <ul style="list-style-type: none"> <li>a. Remove/disassemble.</li> <li>b. Clean.</li> <li>c. Inspect.</li> <li>d. Repair.</li> <li>e. Reassemble/install.</li> </ul>	3-17 3-18 3-18 3-18 3-18
3	Maintain retainer assembly: <ul style="list-style-type: none"> <li>a. Disassemble.</li> <li>b. Clean.</li> <li>c. Inspect.</li> <li>d. Repair/replace.</li> <li>e. Reassemble.</li> <li>f. Install.</li> </ul>	3-20 3-20 3-20 3-20 3-20 3-20
4	Maintain bolt carrier and striker assembly: <ul style="list-style-type: none"> <li>a. Disassemble.</li> <li>b. Clean.</li> <li>c. Inspect.</li> <li>d. Repair.</li> <li>e. Test.</li> <li>f. Reassemble.</li> </ul>	3-21 3-22 3-22 3-22 3-24 3-24

5	Maintain breech bolt:	
	a. Disassemble.	3-25
	b. Clean.	3-25
	c. Inspect.	3-26
	d. Test.	3-27
	e. Repair/replace.	3-27
	f. Reassemble.	3-27
	g. Install.	3-27
6	Maintain upper receiver and barrel assembly:	
	<b>a.</b> Disassemble.	3-29
	<b>b.</b> Inspect/clean.	3-32
	c. Test chamber.	3-32
	d. Test barrel straightness.	3-33
	<b>e.</b> Repair.	3-33
	<b>f.</b> Reassemble.	3-33
	<b>g.</b> Test barrel erosion.	3-37
	<b>h.</b> Test headspace.	3-38
7	Maintain upper receiver assembly:	
	a. Disassemble.	3-39
	b. Inspect/clean.	3-40
	c. Repair.	3-40
	d. Reassemble.	3-41
8	Maintain barrel nut assembly:	
	a. Disassemble.	3-42
	b. Clean.	3-42
	c. Inspect.	3-42
	d. Reassemble.	3-42
	e. Reassemble.	3-43

## 3-2. M231 SUBMACHINE GUN--MAINTENANCE INSTRUCTIONS (cont)

## LIST OF TASKS

Task No.	Task	Task Ref (Page)
9	Maintain barrel and barrel collar assembly: <ul style="list-style-type: none"> <li>a. Inspect.</li> <li>b. Repair/replace.</li> <li>c. Reassemble/install.</li> <li>d. Test.</li> </ul>	3-44 3-44 3-45 3-45
10	Maintain lower receiver and receiver extension assembly: <ul style="list-style-type: none"> <li>a. Disassemble.</li> <li>b. Inspect.</li> <li>c. Test.</li> <li>d. Repair.</li> <li>e. Reassemble.</li> <li>f. Test.</li> </ul>	3-46 3-49 3-50 3-51 3-52 3-59

## 3-3. M231 SUBMACHINE GUN--MAINTENANCE INSTRUCTIONS

## THIS TASK COVERS:

- a. Inspection
- b. Headspace test
- c. Trigger pull test

## INITIAL SETUP

### Tools and Special Tools

Small arms repairman tool kit (SC 5180-95-CL-A07)

Tool and gage set (fig. 11, app C)

### Personnel Required

MOS 45B-10 Small arms repairer

## General Safety Instructions

### WARNING

Before starting any procedures on the M231 submachine gun be sure to clear weapon. Live ammunition should not be near the work area.

## INSPECTION

### NOTE

Direct support maintenance is required to do a complete technical inspection annually, including gaging, on each M231 submachine gun when requested by organizational maintenance. This inspection is performed as a safety measure and to determine serviceability.

- 1 Check that all sliding parts move freely and smoothly.
- 2 Check to see that all spring loaded pins are movable.
- 3 Inspect for obstruction in bore and upper receiver and barrel assembly.
- 4 Inspect for burrs. If present, remove with stone or file.
- 5 Inspect for corrosion.
- 6 Check that setscrew is secure on barrel collar.

## HEADSPACE TEST

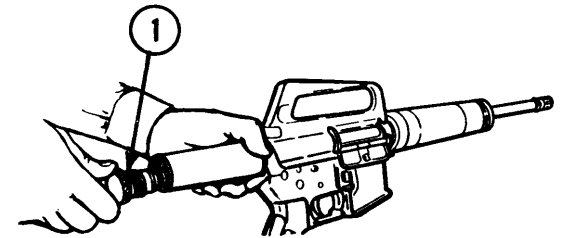

### WARNING

Be careful when removing spring loaded parts. Carelessness could result in injury.

- 1 DRIVE SPRING AND GUIDE ASSEMBLY (1). Turn counterclockwise and remove.

3-3. M231 SUBMACHINE GUN--MAINTENANCE INSTRUCTIONS (cont)

HEADSPACE TEST (cont)

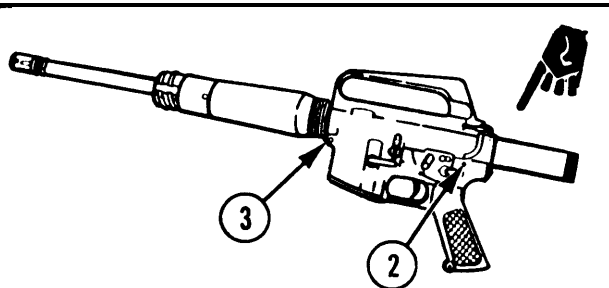

2 TAKEDOWN PIN (2). Pull out as far as it will go.

3 PIVOT PIN (3). Pull out as far as it will go.

**CAUTION**  
Do not drop firing hammer when you pivot the upper receiver and barrel assembly.

4 UPPER RECEIVER AND BARREL ASSEMBLY (4). Remove from lower receiver and receiver extension assembly (5).

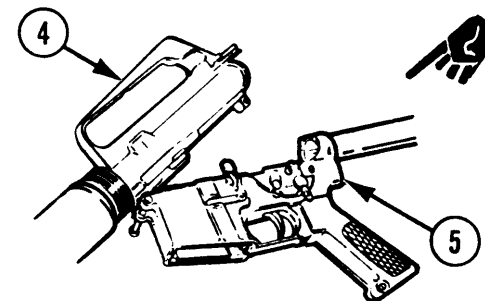

**CAUTION**  
Be careful not to drop the bolt carrier and striker assembly.

5 BOLT CARRIER AND STRIKER ASSEMBLY (6) AND CHARGING HANDLE ASSEMBLY (7). Pull back until breech bolt clears ejection port opening.

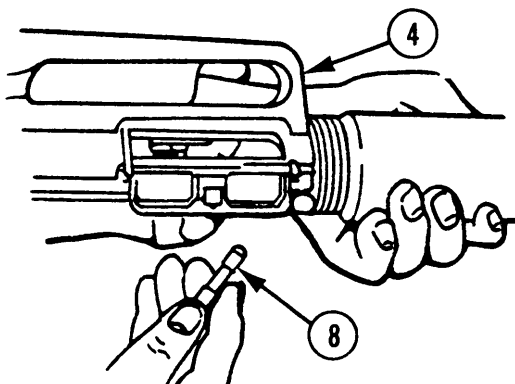

6 HEADSPACE GAGE (8). Insert in chamber of upper receiver and barrel assembly (4).

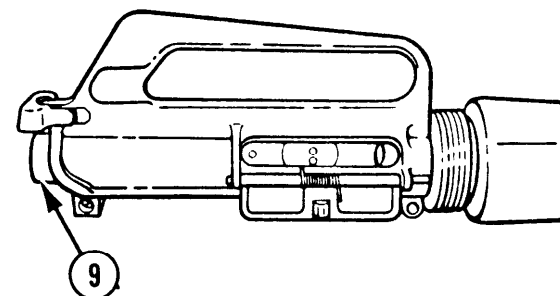

7 FIRING HAMMER (9).

a. Press forward using light finger pressure.

**NOTE**

If firing hammer (9) is flush with rear of upper receiver (10) and/or the bolt carrier and striker assembly closes and locks, the barrel and extension assembly or breech bolt is unserviceable.

- b. Remove from upper receiver and barrel assembly (4).

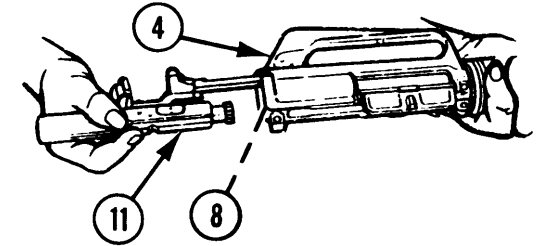
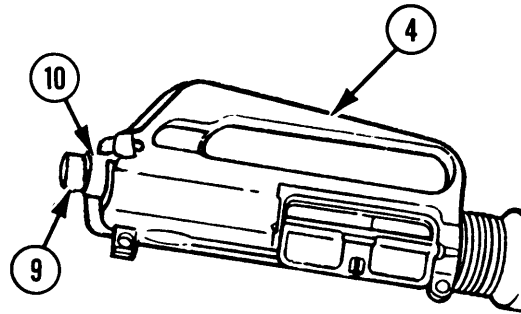

**NOTE**

Catch parts as they fall.

- 8 BOLT CARRIER AND KEY ASSEMBLY (11) WITH ATTACHED PARTS. Remove from upper receiver and barrel assembly (4).
- 9 HEADSPACE GAGE (8). Remove.

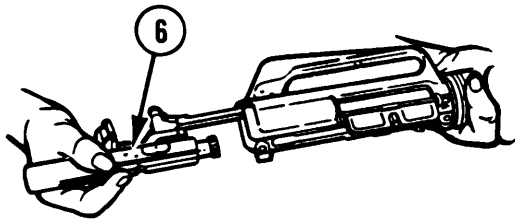

- 10 BOLT CARRIER AND STRIKER ASSEMBLY (6). Install.

- 11 UPPER RECEIVER AND BARREL ASSEMBLY (4).

- a. Position on lower receiver and receiver extension assembly (5).
- b. Secure by pushing in on takedown pin (2) and pivot pin (3).

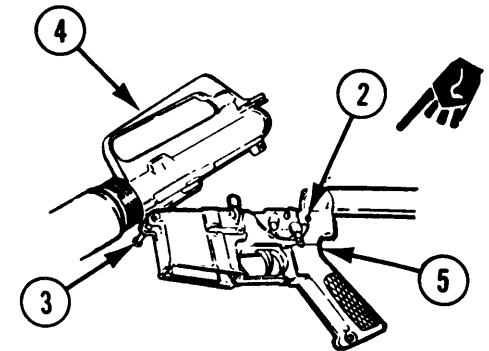

## 3-3. M231 SUBMACHINE GUN--MAINTENANCE INSTRUCTIONS (cont)

## HEADSPACE TEST (cont)

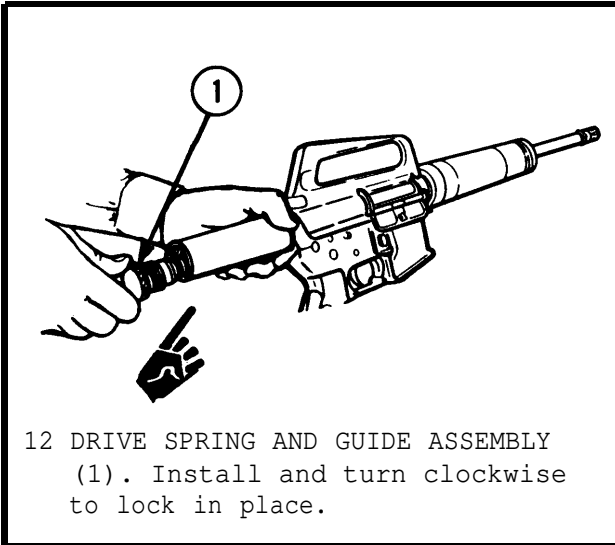

## TRIGGER PULL TEST

- 1 M231 SUBMACHINE GUN (1).
- a. With cartridge magazine removed and selector lever on AUTO position, charge weapon.
- b. Hold in vertical position.

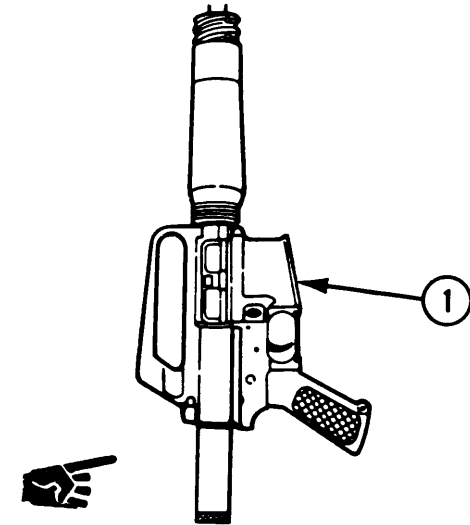

## 2 TRIGGER PULL MEASURING FIXTURE (2).

- a. Install on trigger (3).
- b. Add weights until weapon fires.

**NOTE**

Weapon should not fire until 19 lbs have been applied, and it must fire before applying 25 lbs.

- c. Determine weight applied.
- d. If weapon did not fire within the prescribed limits, repair or replace as necessary any or all of the following: trigger, helical torsion spring, helical sear spring, and sear (p 3-45).

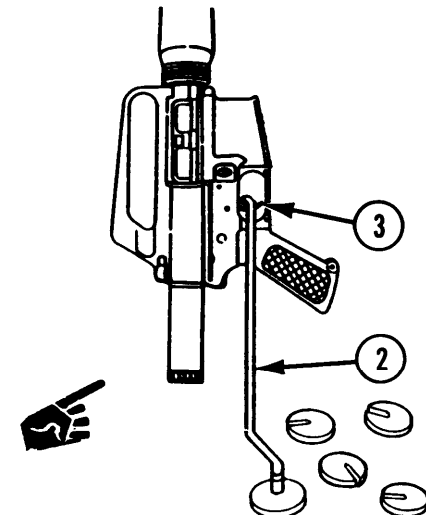

### 3-4. DRIVE SPRING AND GUIDE ASSEMBLY--MAINTENANCE INSTRUCTIONS

THIS TASK COVERS:

- a. Removal/disassembly
- b. Cleaning
- c. Inspection
- d. Repair
- e. Reassembly/installation

#### INITIAL SETUP

##### Tools and Special Tools

Small arms repairman tool kit (SC 5180-95-CL-A07)

##### Personnel Required

MOS 45B-10 Small arms repairer

##### Materials/Parts

Lubricating oil (LSA) (item 16, app D)

Wiping rag (item 18, app D)

##### References

Appendix C

Appendix D

#### REMOVAL/DISASSEMBLY

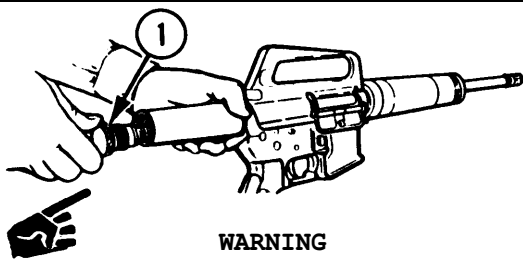

##### WARNING

Be careful when removing spring loaded parts. Carelessness could result in injury.

- 1 DRIVE SPRING AND GUIDE ASSEMBLY (1). Turn counterclockwise and remove.

- 2 OUTER HELICAL COMPRESSION SPRING (2), MIDDLE HELICAL COMPRESSION SPRING (3), AND INNER HELICAL COMPRESSION SPRING (4). Remove from retainer assembly (5).
- 3 FLAT WASHER (6) AND RECOIL BUFFER (7). Remove from retainer assembly (5).

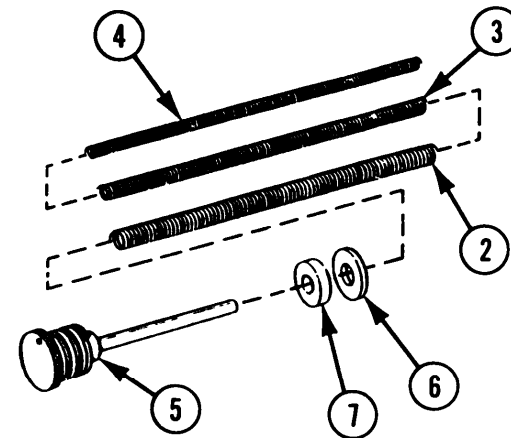

## 3-4. DRIVE SPRING AND GUIDE ASSEMBLY--MAINTENANCE INSTRUCTIONS (cont)

**CLEANING**

ALL PARTS. Wipe off with wiping rag (item 18, app D).

**INSPECTION**

## 1 SPRING RETAINER (1).

- a. Inspect seating surface for cracks, breaks, and burrs.
- b. If present, remove burrs with a stone or file.

## 2 RETAINER ROD (2).

- a. Check for bends, deformation, cracks, and burrs.
- b. If present, remove burrs with a stone or file.

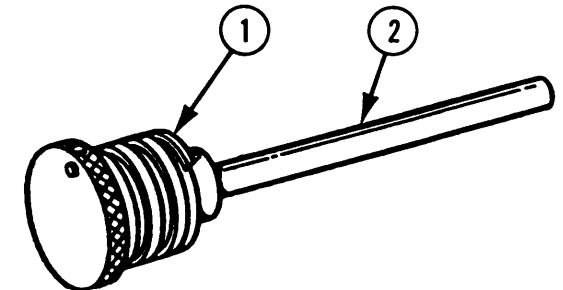

## 2.1 HELICAL COMPRESSION SPRINGS.

- a. Check for breaks or kinks.
- b. Measure free length of springs with steel tape measure.
  - (1) The outer and middle spring's free length is between 9 5/8 and 10 3/8 in. (24.5 and 26.4 cm).
  - (2) Inner spring's free length will be between 7 1/8 and 7 5/8 in. (18.1 and 19.4 cm).

## 3 ALL REMAINING PARTS. Check for breaks, bends, or kinks.

**REPAIR**

Repair is by replacement of authorized parts (app C) as required.

**NOTE**

For repair of the retainer assembly refer to page 3-19.

## REASSEMBLY/INSTALLATION

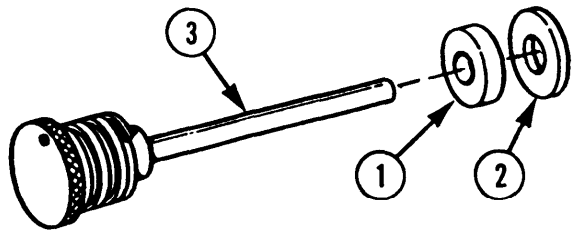

1 RECOIL BUFFER (1) AND FLAT WASHER (2). Lightly lube with lubricating oil (LSA) (item 16, app D) and place on retainer assembly (3).

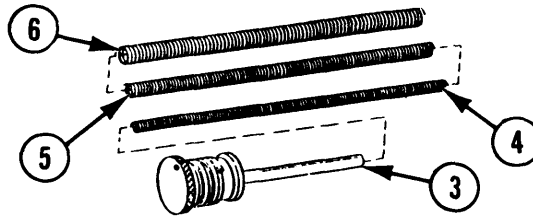

2 INNER HELICAL COMPRESSION SPRING (4), MIDDLE HELICAL COMPRESSION SPRING (5), AND OUTER HELICAL COMPRESSION SPRING (6). Lightly lube with lubricating oil (LSA) (item 16, app D) and place on retainer assembly (3).

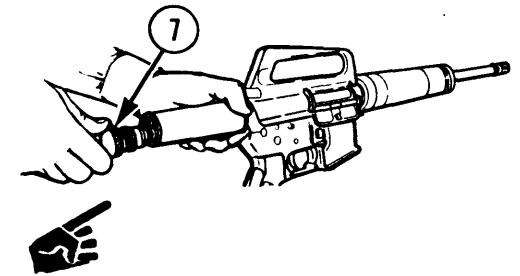

3 DRIVE SPRING AND GUIDE ASSEMBLY (7). Install and turn clockwise to lock in place.

## 3-5. RETAINER ASSEMBLY--MAINTENANCE INSTRUCTIONS

### THIS TASK COVERS:

- a. Disassembly
- b. Cleaning
- c. Inspection
- d. Repair/replacement
- e. Reassembly
- f. Installation

### INITIAL SETUP

#### Tools and Special Tools

Small arms repairman tool kit (SC 5180-95-CL-A07)

#### Materials/Parts

Wiping rag (item 18, app D)

#### Personnel Required

MOS 45B-10 Small arms repairer

#### References

3-18 Reassembly/installation of drive spring and guide assembly  
Appendix C  
Appendix D

#### Equipment Condition

3-17 Retainer assembly removed from drive spring and guide assembly

## 3-5. RETAINER ASSEMBLY--MAINTENANCE INSTRUCTIONS (cont)

## DISASSEMBLY

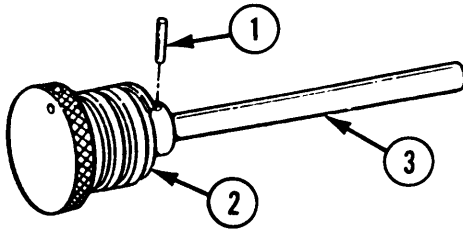
**NOTE**

Only remove spring pin (1) if it is damaged.

SPRING PIN (1). Remove from spring retainer (2) and retainer rod (3) using 1/16-inch punch.

## CLEANING

ALL PARTS. Wipe with wiping rag (item 18, app D).

## INSPECTION

RETAINER ASSEMBLY.

- a. Inspect for bends, breaks, or other deformation.
- b. Inspect for burrs, remove with a stone or file if present.

## REPAIR/REPLACEMENT

Repair is by replacement of authorized parts (app C) as required.

## REASSEMBLY

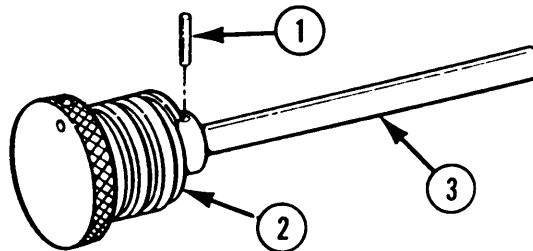

SPRING PIN (1). Install into spring retainer (2) through retainer rod (3).

## INSTALLATION

For installation procedures, refer to the reassembly/installation of the drive spring and guide assembly on page 3-18.

### 3-6. BOLT CARRIER AND STRIKER ASSEMBLY--MAINTENANCE INSTRUCTIONS

#### THIS TASK COVERS:

- a. Disassembly
- b. Cleaning
- c. Inspection
- d. Repair
- e. Test
- f. Reassembly

#### INITIAL SETUP

##### Tools and Special Tools

- Key tool (C-11, app C)
- Small arms repairman tool kit (SC 5180-95-CL-A07)
- Small arms shop set (SC 4933-95-CL-A11)
  - Number 36 drill bit
- Tool and gage set (fig. 11, app C)

##### Materials/Parts

- Inspection penetrant kit (item 12, app D)
- Rifle bore cleaning compound (RBC) (item 8, app D)

##### Personnel Required

- MOS 45B-10 Small arms repairer

##### References

- Appendix C
- Appendix D
- Appendix E

##### Equipment Conditions

- 2-15 Bolt carrier and striker assembly removed

##### General Safety Instructions

#### WARNING

To avoid possible explosion, never exchange or switch bolt carrier and striker assembly from one weapon to another.

### DISASSEMBLY

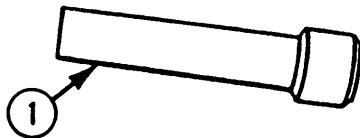

#### NOTE

The firing hammer (1) was removed when the M231 submachine gun was disassembled.

- 1 FIRING PIN RETAINING PIN (2). Remove from bolt carrier and key assembly (3) using 1/16-inch punch.
- 2 FIRING PIN (4). Remove by tipping bolt carrier and key assembly (3).

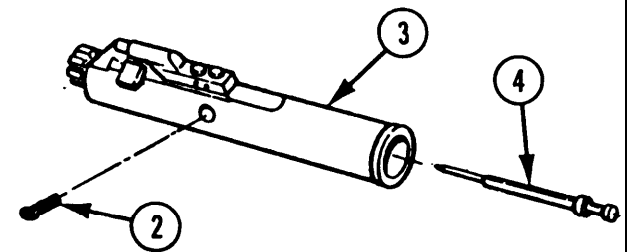

## 3-6. BOLT CARRIER AND STRIKER ASSEMBLY--MAINTENANCE INSTRUCTIONS (cont)

## DISASSEMBLY (cont)

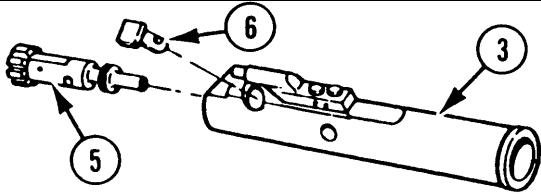

- 3 BREECH BOLT (5). Push back.
- 4 BOLT CAM PIN (6). Rotate 1/4 turn and lift straight up to remove from bolt carrier and key assembly (3).
- 5 BREECH BOLT (5). Pull to remove.

## CLEANING

ALL PARTS. Clean with rifle bore cleaning compound (RBC) (item 8, app D).

## INSPECTION

## 1 FIRING PIN.

- a. Check tip for proper contour. Inspect for wear, chips, pits, and burrs.
- b. If present, remove burrs with a stone or file.

**NOTE**

Use inspection penetrant kit according to instructions contained in kit.

## REPAIR

## 2 ALL REMAINING PARTS.

- a. Check for cracks using inspection penetrant kit (item 12, app D).
- b. Check for chips and burrs.
- c. If present, remove burrs with a stone or file.

## CAUTION

Be careful during the following procedure to make sure that the striking force is not directed to the attaching screws and that the tube portion is not enlarged or flared beyond original requirements. Such enlargement would permit loss of gas pressure when the key and gas metallic bent tube come together during functioning.

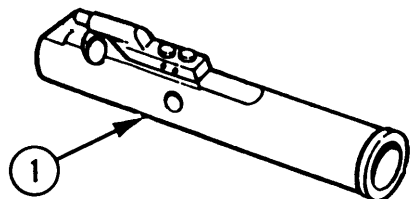

1 BOLT CARRIER AND KEY ASSEMBLY (1). Repair small dents and/or distortions with the key tool as follows:

- a. Place the bolt carrier and key assembly (1) in a vertical position, supported so that contact is made with the rear surface of the key (2).
- b. Insert the small end of the key tool (3) into the tube portion of the key.
- c. Strike the large end of the key tool (lightly) with a 3-ounce soft brass hammer (4).
- d. Repeat striking (gently) until the key is reformed to original configuration.

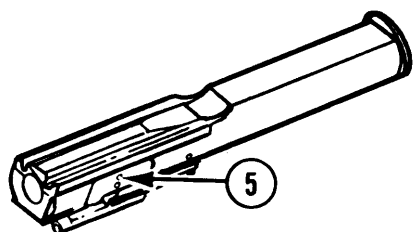
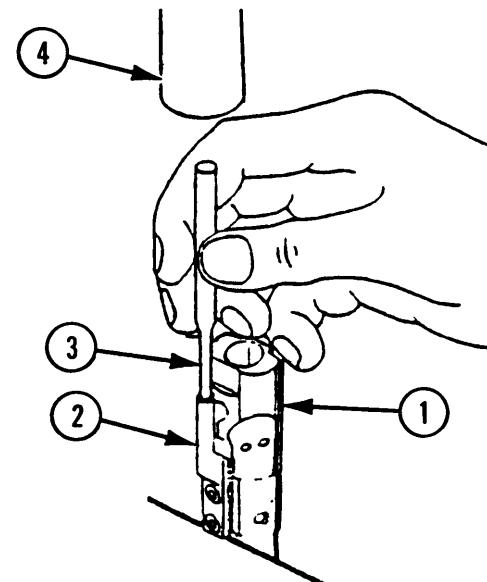

2 GAS RELIEF PORTS (5). Ream large buildup of carbon from gas relief ports (5) using a no. 36 drill bit. Hand hold drill bit and use a back and forth motion to clear gas relief ports.

3 ALL PARTS. Repair is by replacement of authorized parts (app C) as required.

**NOTE**

For repair of the breech bolt refer to page 3-25.

**TEST**

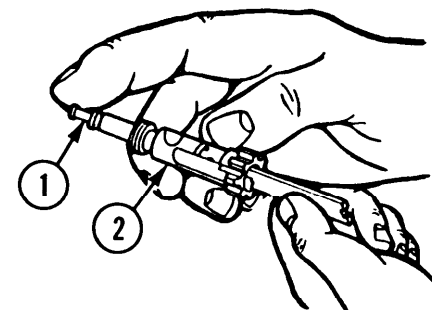

FIRING PIN (1).

- a. Insert through breech bolt (2) and hold in place with finger pressure.

## 3-6. BOLT CARRIER AND STRIKER ASSEMBLY--MAINTENANCE INSTRUCTIONS (cont)1

**TEST (cont)**

## FIRING PIN (1). (cont)

- b. Check for proper firing pin protrusion using firing pin protrusion gage (3).
- c. End of firing pin should touch MIN. .028 portion and should clear MAX. .036 end of firing pin protrusion gage.
- d. Replace firing pin (app C) if defective.

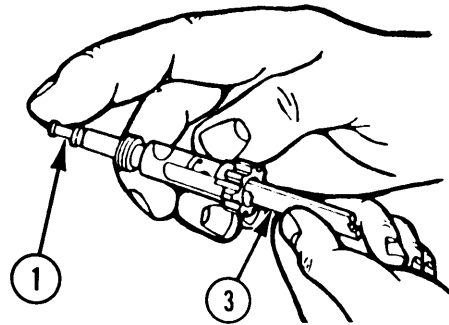
**REASSEMBLY****WARNING**

Bolt can pin must be installed or weapon will blow up when the first round is fired.

## 1 BREECH BOLT (1).

- a. Install in bolt carrier and key assembly (2).
- b. Pull back until hole is aligned with hole in bolt carrier and key assembly where bolt cam pin (3) is installed.

2 BOLT CAM PIN (3). Install through holes and rotate 1/4 turn to align firing pin hole.

**NOTE**

If bolt cam pin cannot be fully inserted, remove bolt cam pin, rotate breech bolt 180°, and install bolt cam pin.

3 BOLT CARRIER AND KEY ASSEMBLY (2). Hold with breech bolt end down.

4 FIRING PIN (4). Drop into place from rear of bolt carrier and key assembly (2).

5 FIRING PIN RETAINING PIN (5). Press into larger opening of bolt carrier and key assembly (2).

**NOTE**

To be sure of proper installation, attempt to shake out firing pin.

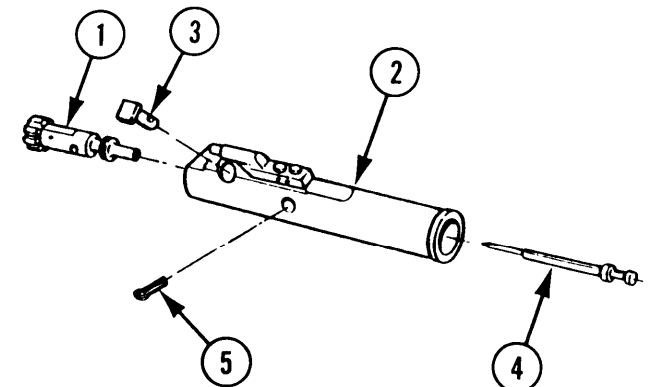

### 3-7. BREECH BOLT--MAINTENANCE INSTRUCTIONS

#### THIS TASK COVERS:

- a. Disassembly
- b. Cleaning
- c. Inspection
- d. Test
- e. Repair/replacement
- f. Reassembly
- g. Installation

#### INITIAL SETUP

##### Tools and Special Tools

Small arms repairman tool kit (SC 5180-95-CL-A07)  
Tool and gage set (fig. 11, app C)

##### Materials/Parts

Inspection penetrant kit (item 12, app D)  
Rifle bore cleaning compound (RBC) (item 8, app D)

##### Personnel Required

MOS 45B-10 Small arms repairer

##### References

3-24 Reassembly of bolt carrier and striker assembly

Appendix C

Appendix D

##### Equipment Conditions

2-15 Bolt carrier and striker assembly removed

3-21 Breech bolt removed

### DISASSEMBLY

#### CAUTION

Take care not to damage bolt rings or breech bolt.

THREE BOLT RINGS (1). Remove from bolt (2) using small screwdriver (3).

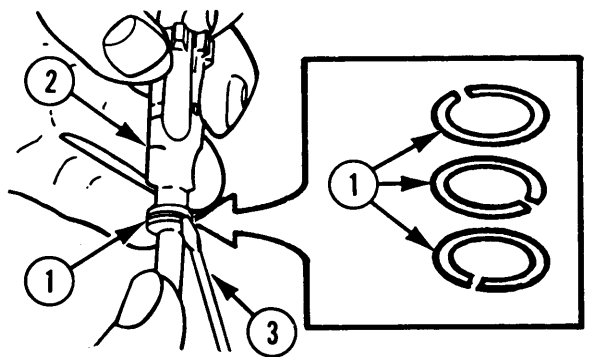

### CLEANING

BOLT AND THREE BOLT RINGS. Clean with rifle bore cleaning compound (RBC) (item 8, app D).

---

 3-7. BREECH BOLT--MAINTENANCE INSTRUCTIONS (cont)
 

---

**INSPECTION**

- 1 THREE BOLT RINGS (1). Inspect for cracks, kinks, and bends.
- 2 BOLT (2).

**NOTE**

Use inspection penetrant kit according to instructions contained in kit.

- a. Inspect for cracks in bolt cam pin hole area (3), locking lugs (4), and bolt face, using inspection penetrant kit (item 12, app D). Pay special attention to the area where the locking lugs meet the body.

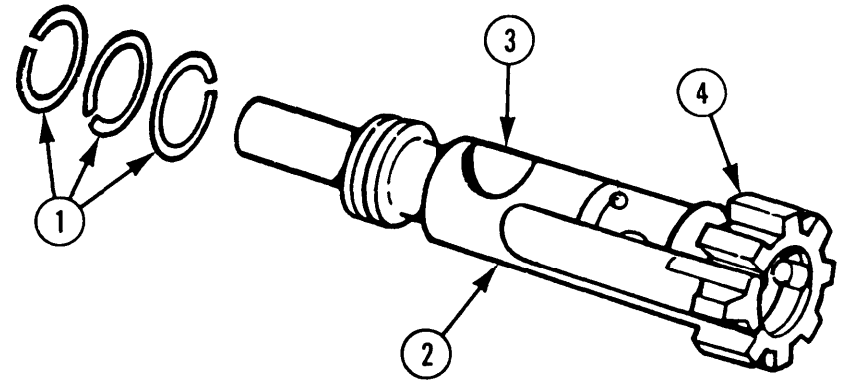
**NOTE**

Breech bolts that contain pits extending into the bolt firing pin hole will not be rejected unless excess wear is determined.

- b. Inspect exterior surface for large pits or clusters of pits.
- c. Inspect for burrs, remove with a stone or file if present.

## TEST

**BOLT FIRING PIN HOLE (1).** Test for oversize or out-of-round hole by performing the following procedures:

- a. Attempt to insert plain plug gage (2) (12620101) into bolt firing pin hole (1) by gage weight only, do not press.
- b. Rotate plain plug gage (2) to determine if bolt firing pin hole is elongated.
- c. Entry of plain plug gage (2) in bolt firing pin hole (1) is cause for replacement of the breech bolt.

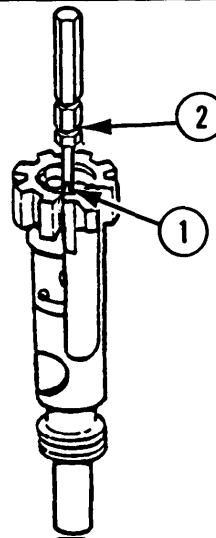

## REPAIR/REPLACEMENT

Repair is by replacement of authorized parts (app C) as required.

## REASSEMBLY

### NOTE

Be sure bolt ring gaps are staggered to prevent loss of gas pressure.

THREE BOLT RINGS (1). Install in slot on bolt (2).

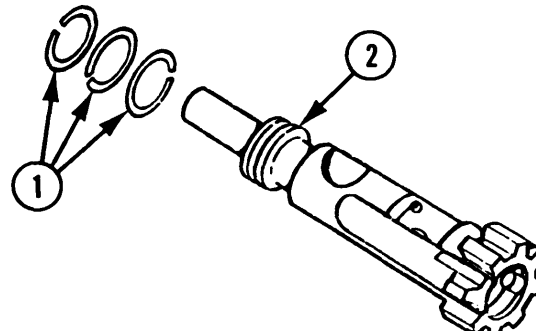

## INSTALLATION

For installation procedures, refer to the reassembly of the bolt carrier and striker assembly (p 3-24).

## 13-8. UPPER RECEIVER AND BARREL ASSEMBLY--MAINTENANCE INSTRUCTIONS

## THIS TASK COVERS:

- |                             |                        |
|-----------------------------|------------------------|
| a. Disassembly              | e. Repair              |
| b. Inspection/cleaning      | f. Reassembly          |
| c. Chamber test             | g. Barrel erosion test |
| d. Barrel straightness test | h. Headspace test      |

## INITIAL SETUP

## Tools and Special Tools

Small arms cleaning brush (11686340)  
Small arms repairman tool kit (SC 5180-95-CL-A07)  
Tool and gage" set (fig. 11, app C)

## References

Appendix C  
Appendix D  
TM 9-1005-309-10

## Materials/Parts

Molybdenum disulfide grease item 11, app D  
Rifle bore cleaning compound (RBC) (item 8, app D)  
Wiping rag (item 18, app D)

## Equipment Conditions

2-15 Upper receiver and barrel assembly removed

## Personnel Required

Mos 45B-10 Small arms repairer  
Helper

## DISASSEMBLY

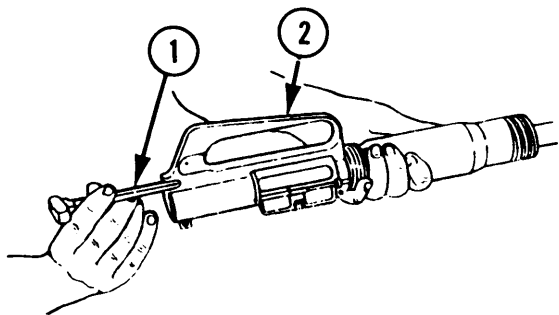

- 1 CHARGING HANDLE ASSEMBLY (1).  
Pull back and push down to remove from upper receiver assembly (2).

- 2 TWO HANDGUARDS (3).

### NOTE

Two soldiers may be required to remove handguards.

- a. Point barrel upward and have helper push down on barrel nut assembly (4).
- b. Repairer pivots each handguard (3) outward to remove.

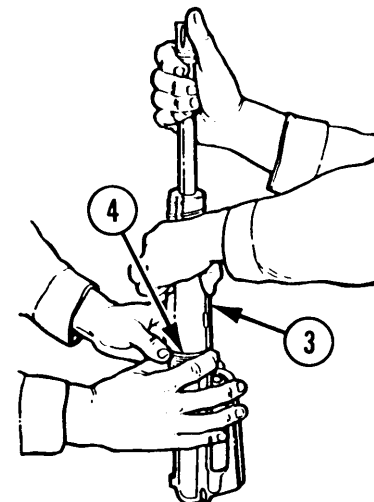

- 3 FLASH SUPPRESSOR (5).

- a. Place barrel remover fixture (6) in vise.
- b. Position upper receiver and barrel assembly in barrel remover fixture (6) with flash suppressor (5) close to barrel remover fixture and tighten vise.
- c. Loosen flash suppressor (5) using combination barrel nut and flash suppressor wrench (7) and 1/2-inch drive handle (8). Turn counterclockwise to loosen.
- d. Remove flash suppressor (5) and flash suppressor lockwasher (9) from barrel and extension assembly (10).

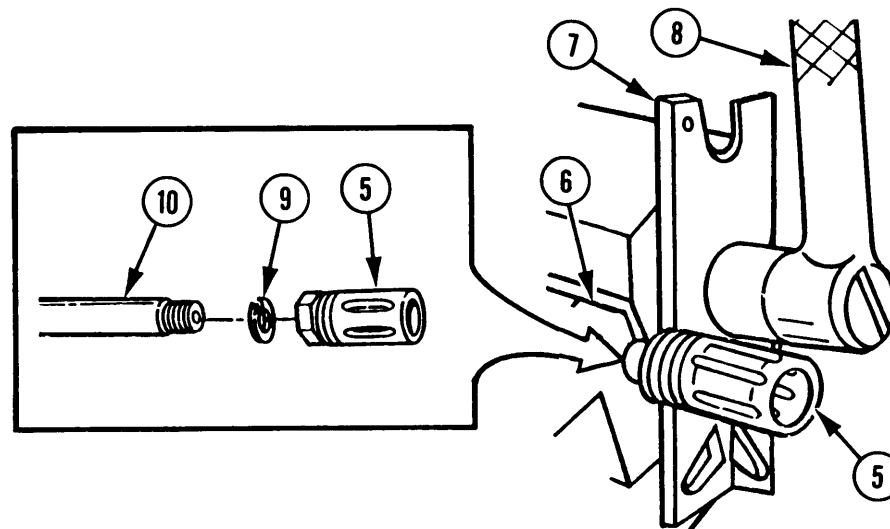

## 3-8. UPPER RECEIVER AND BARREL ASSEMBLY--MAINTENANCE INSTRUCTIONS (cont)

## DISASSEMBLY (cont)

## 4 BARREL COLLAR (11).

- a. Remove setscrew (12).
- b. With carrying handle (13) in position illustrated (left side up), drive out two plain tapered (14) using 3/32-inch punch.
- c. Remove from vise.

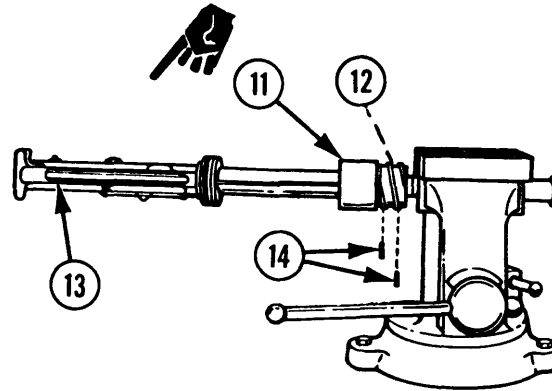
**NOTE**

If barrel collar cannot be removed from barrel and extension assembly, soak in rifle bore cleaning compound (RBC) (item 8, app D) for a period of 2 to 8 hours.

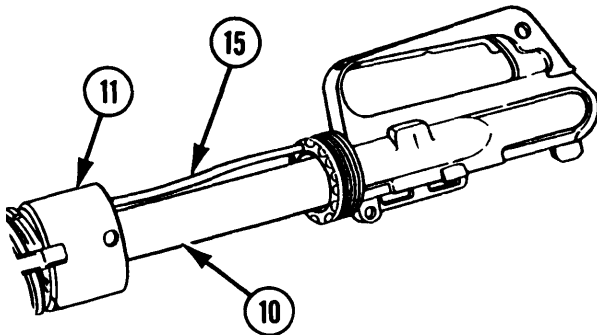

- d. Hold gas metallic bent tube (15) and slide barrel collar (11) off of barrel and extension assembly (10).

**NOTE**

Be careful not to lose gas seal.

- 5 GAS METALLIC BENT TUBE (15) AND GAS SEAL (16). Lift up slightly and **remove** by pulling out of barrel nut assembly (17).

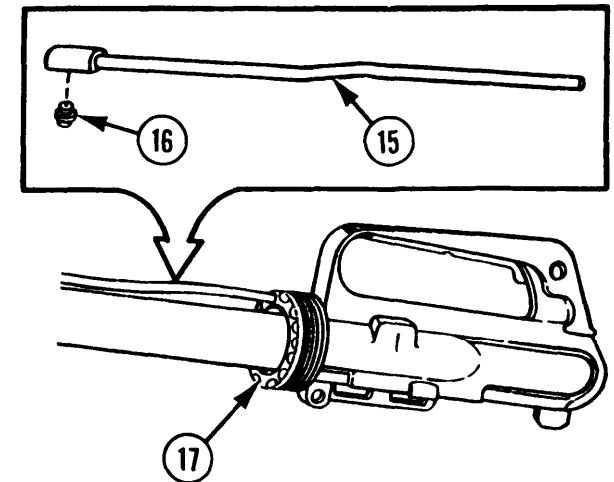

6 BARREL NUT ASSEMBLY (17).

- a. Place barrel remover fixture (6) in vise.
- b. Position barrel and extension assembly in fixture and tighten vise.

Push the combination barrel nut and flash suppressor wrench

- c. (7) down to compress the slip ring spring (18). Be sure the three drive pins on the combination barrel nut and flash suppressor wrench are fully engaged with barrel nut assembly (17).
- d. Use combination barrel nut and flash suppressor wrench (7) and 1/2-inch drive handle (8) to loosen barrel nut assembly (17).

7 UPPER RECEIVER ASSEMBLY (2). Separate and remove from barrel and extension assembly (10).

8 BARREL AND EXTENSION ASSEMBLY (10).

- a. Remove from vise.
- b. Remove barrel nut assembly (17).

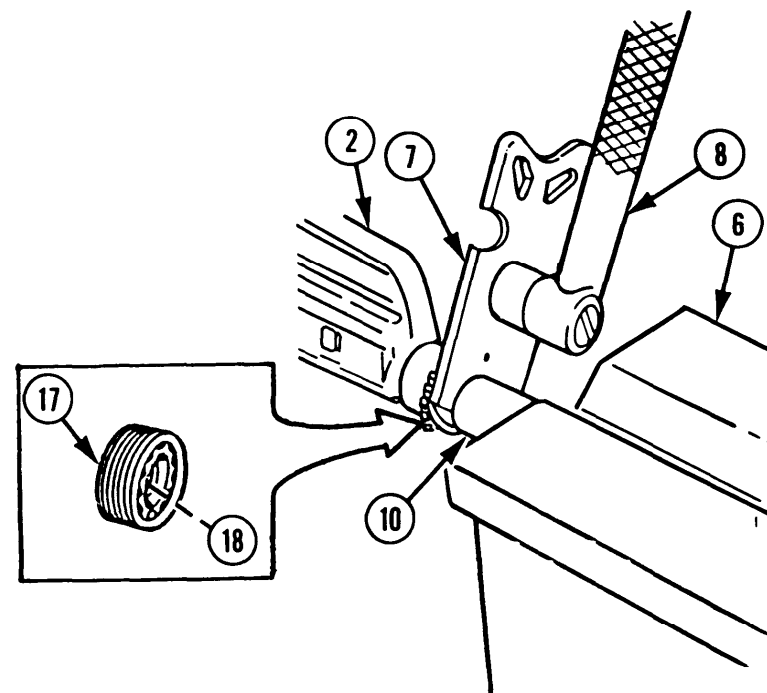

### 3-8. UPPER RECEIVER AND BARREL ASSEMBLY--MAINTENANCE INSTRUCTIONS (cont)

#### INSPECTION/CLEANING

##### 1 ALL PARTS.

- a. Wipe off with wiping rag (item 18, app D).
- b. Remove carbon with rifle bore cleaning compound (RBC) (item 8, app D) and small arms cleaning brush.
- c. Inspect for wear, damage, and burrs.
- d. If present, remove burrs with a stone or file.



##### 2 GAS METALLIC BENT TUBE (1).

- a. Check for carbon deposits on exterior.
- b. If present, remove carbon with small arms cleaning brush and rifle bore cleaning compound (RBC) (item 8, app D).

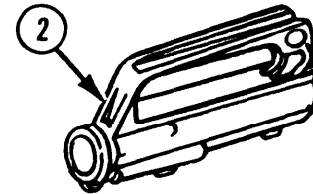

- ##### 3 UPPER RECEIVER ASSEMBLY (2).
- Check for cracks, corrosion, damaged threads, and mutilation.

#### CHAMBER TEST

##### BARREL AND EXTENSION ASSEMBLY (1).

- a. Insert chamber reflector tool (2) in chamber.
- b. Rotate to allow light to shine into chamber. Use flashlight if necessary.
- c. Inspect for presence of pits 1/8 inch (0.318 cm) in length and large enough to extend from the body of the chamber into the shoulder stop area and forcing cone area. If present, replace barrel and barrel collar assembly (p 3-28).

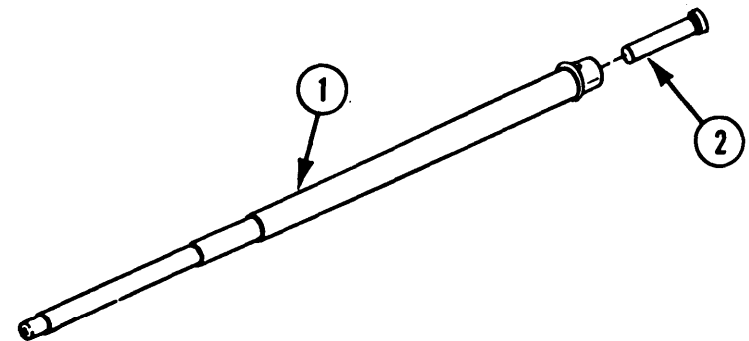

## BARREL STRAIGHTNESS TEST

- 1 STRAIGHTNESS GAGE (1). Insert in barrel and extension assembly (2).
- 2 BARREL AND EXTENSION ASSEMBLY (2). Tilt to allow straightness gage (1) to slide through barrel. Catch straightness gage.

### NOTE

Straightness gage (1) must pass freely through barrel and extension assembly. If not, the barrel and extension assembly is unserviceable.

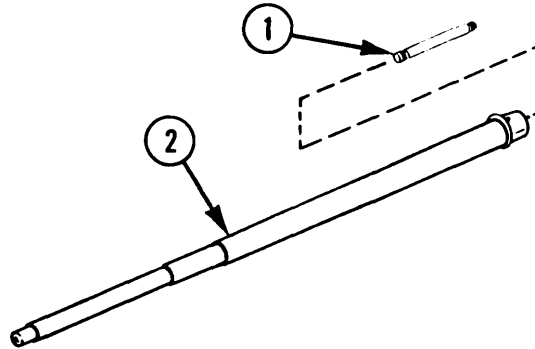

Repair is by replacement of authorized parts (app C) as required.

### NOTE

For repair of the upper receiver assembly, refer to page 3-39. For repair of the barrel nut assembly, refer to page 3-41. For repair of the barrel and barrel collar assembly, refer to page 3-43.

## REASSEMBLY

- 1 BARREL NUT ASSEMBLY (1). Slide on barrel and extension assembly (2) with retaining ring side toward alignment pin (3).
- 2 BARREL AND EXTENSION ASSEMBLY (2). Place in barrel remover fixture (4) with alignment pin (3) up and tighten vise to hold securely.
- 3 UPPER RECEIVER ASSEMBLY (5). Using alignment pin (3) and slot in upper receiver assembly, align and install over end of barrel and extension assembly (2).
- 4 BARREL NUT ASSEMBLY (1).
  - a. Apply light coat of molybdenum disulfide grease (item 11, app D) to the threads.
  - b. Engage threads with upper receiver assembly (5).

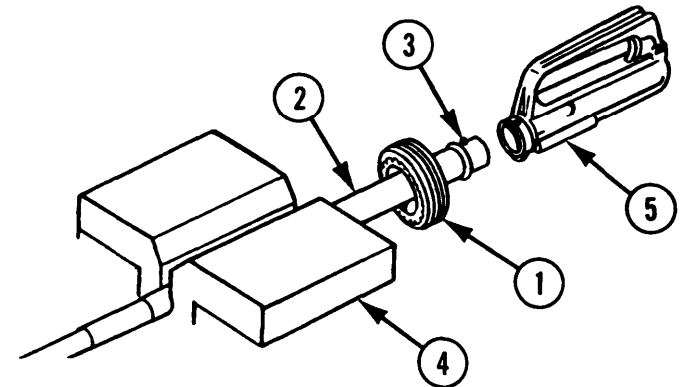

## 3-8. UPPER RECEIVER AND BARREL ASSEMBLY--MAINTENANCE INSTRUCTIONS (cont)

## REASSEMBLY (cont)

## 4 BARREL NUT ASSEMBLY (1). (cont)

**NOTE**

Loosen and repeat torque operation three times when working with a new barrel and extension assembly.

- c. Use combination barrel nut and flash suppressor wrench (6) and torque wrench (7) to torque barrel nut assembly (1) to 35 ft-lb (47.46 **N·m**)

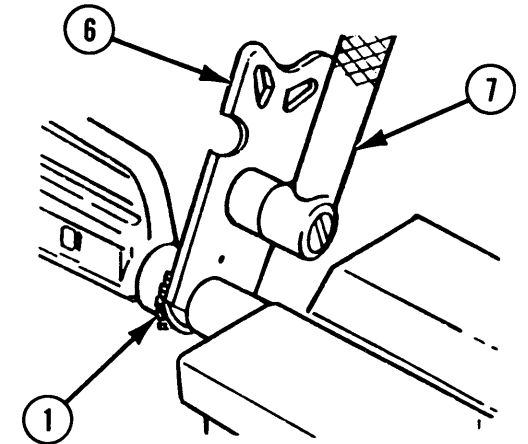

- d. Deleted.

- e. Align barrel nut assembly (1) with upper receiver assembly (5) using gas metallic bent tube (8) as a guide.

- f. Tighten barrel nut assembly (1) to next hole to allow proper alignment with gas metallic bent tube.

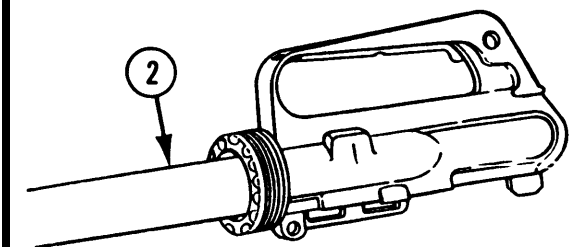
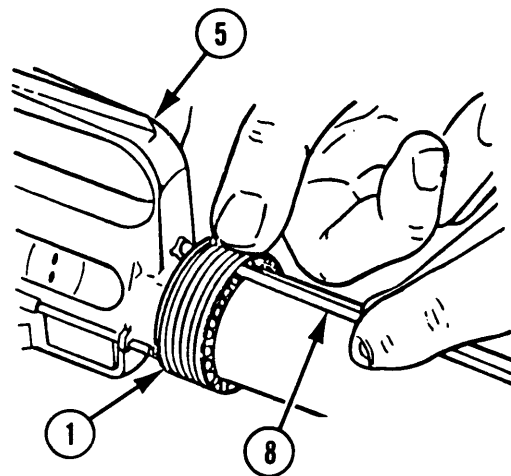

- 5 BARREL AND EXTENSION ASSEMBLY (2) WITH ATTACHED PARTS. Remove from barrel remover fixture.

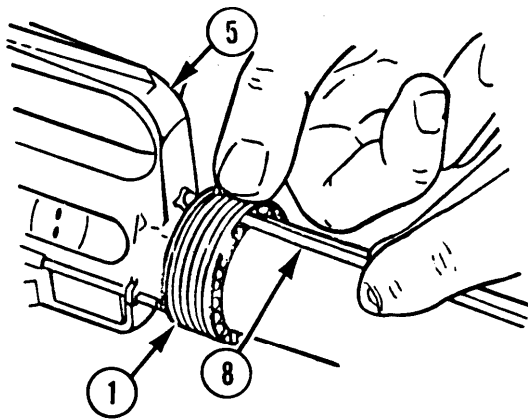

6 GAS METALLIC BENT TUBE (8). Install through barrel nut assembly (1) into upper receiver assembly (5).

- 7 GAS SEAL (9). Install in barrel and extension assembly recess and gas metallic bent tube (8).
- 8 BARREL COLLAR (10). Slide over barrel and extension assembly aligning with gas metallic bent tube (8) and aligning holes in barrel collar (10) with groove in barrel and extension assembly.

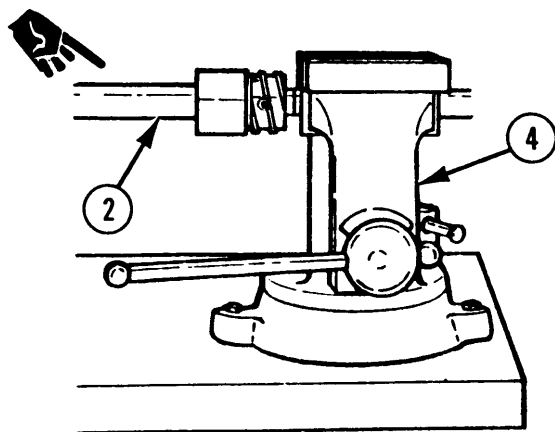
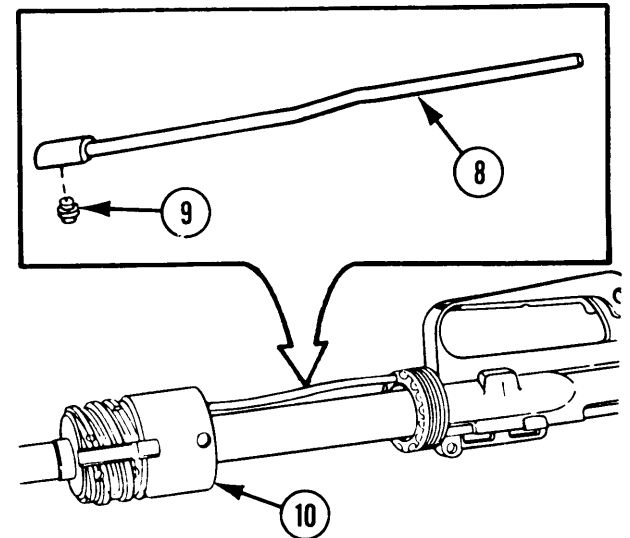

9 BARREL AND EXTENSION ASSEMBLY (2) WITH ATTACHED PARTS. Place in barrel remover fixture (4) and tighten in vise.

- 10 SETSCREW (11). Install and tighten just enough to secure.
- 11 TWO PLAIN TAPERED PINS (12).

**NOTE**

Insert small ends of plain tapered pins first in holes.

- a. With right side of weapon up, install plain tapered pins (12).
- b. Seat plain tapered pins using a 1/8-inch punch.

- 12 SETSCREW (11). Tighten to 150 to 170 in.-lb (16.95 to 19.21 N•m) torque using 3/16-inch sockethead screw socket wrench.

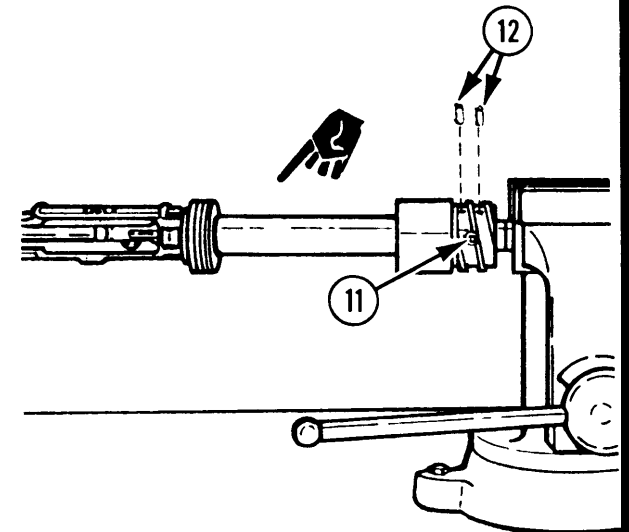

## 3-8. UPPER RECEIVER AND BARREL ASSEMBLY--MAINTENANCE INSTRUCTIONS (cont)

## REASSEMBLY (cont)

13 FLASH SUPPRESSOR LOCKWASHER (13) AND FLASH SUPPRESSOR (14).

- Install on barrel and extension assembly (2).
- Using combination barrel nut and flash suppressor wrench (6) and torque wrench (7), tighten to 25 to 30 ft-lb I (33.90 to **40.68 N·m**) torque.

14 BARREL AND EXTENSION ASSEMBLY (2) WITH ATTACHED PARTS. Remove from barrel remover fixture.

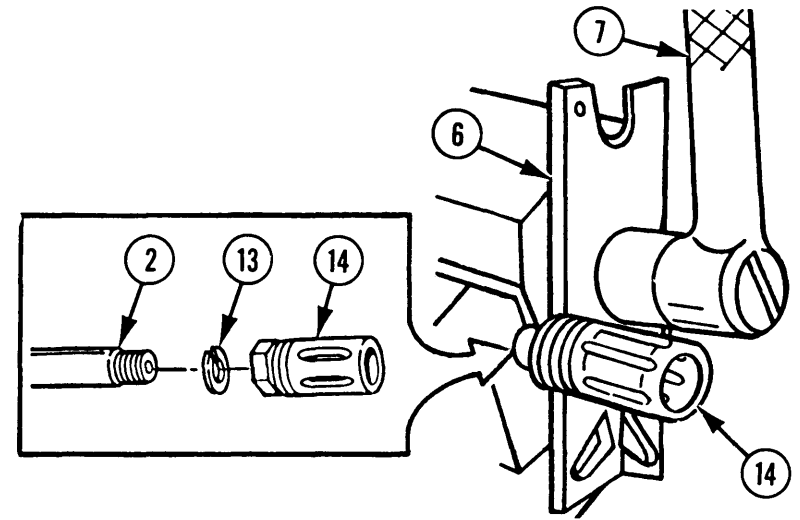

15 TWO HANDGUARDS (15).

**NOTE**

TWO soldiers may be required to install handguards.

- Point barrel and extension assembly upward and have helper pull down on barrel nut assembly (1).
- Repairer inserts top of each handguard (15) into barrel collar (10) and pivots handguard downward against barrel and extension assembly.
- Release barrel nut assembly (1).

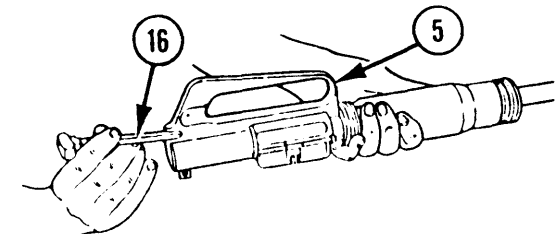
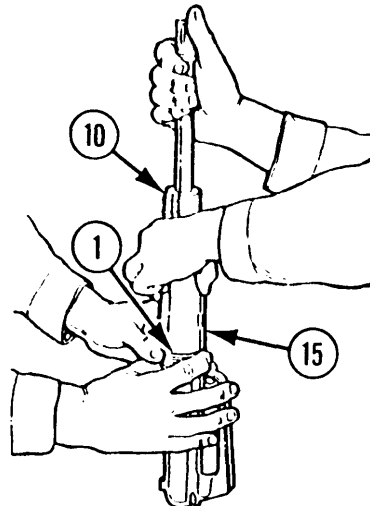

16 CHARGING HANDLE ASSEMBLY (16).

- Align detents on charging handle assembly with slots in upper receiver assembly (5).
- Lift up and push forward to install.

BARREL EROSION TEST

1 BOLT CARRIER AND STRIKER ASSEMBLY (1). Disassemble (p 2-24).

2 BOLT CARRIER AND KEY ASSEMBLY (1.1). Aline key with charging handle assembly and insert into upper receiver and barrel assembly (2).

3 BOLT CARRIER AND KEY ASSEMBLY (1.1) AND CHARGING HANDLE ASSEMBLY (3). Press forward using light finger pressure.

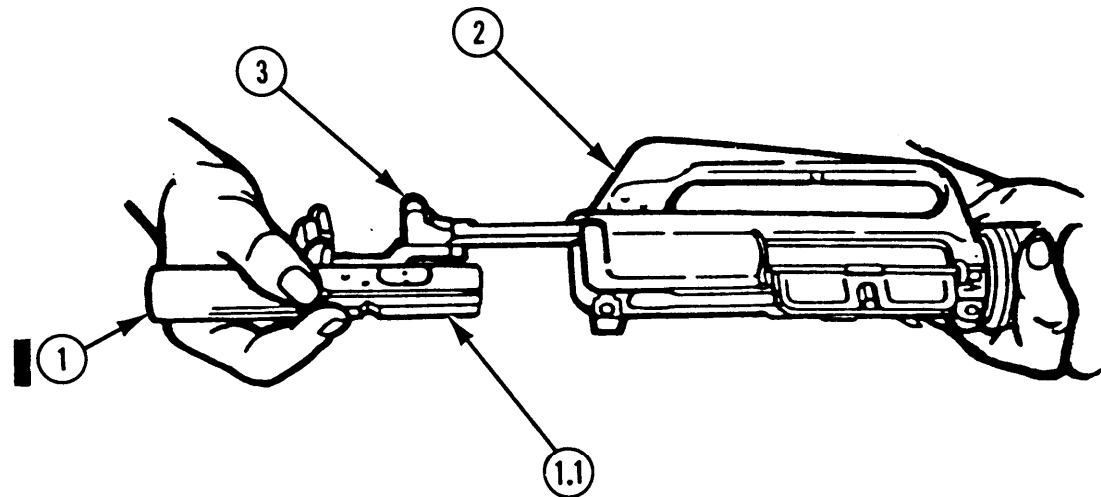

4 BARREL EROSION GAGE (4), P/N 12551887.

- a. Insert into breech end of barrel and extension assembly (5) and through bolt carrier and key assembly (1.1).
- b. Check that barrel erosion gage (4) does not go beyond rejection mark (6), when sighting across rear flats of upper receiver (7).

**NOTE**

If barrel erosion gage goes past the rejection mark, the barrel and barrel extension assembly is unserviceable and must be replaced.

5 BARREL EROSION GAGE (4) AND BOLT CARRIER AND KEY ASSEMBLY (1.1). Remove.

6 BOLT CARRIER AND STRIKER ASSEMBLY. Assemble (p 2-27).

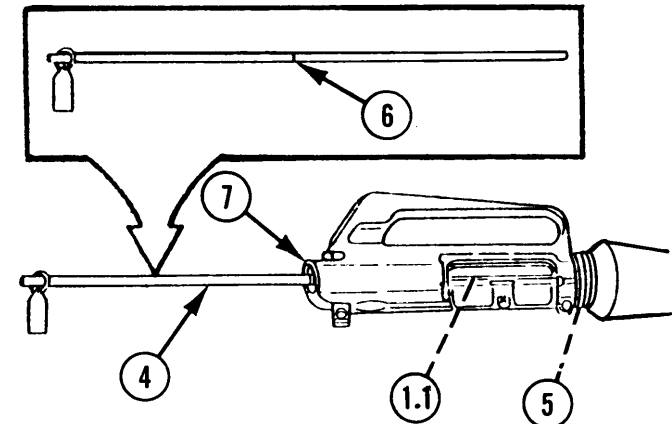

## 3-8. UPPER RECEIVER AND BARREL ASSEMBLY--MAINTENANCE INSTRUCTIONS (cont)

## HEADSPACE TEST

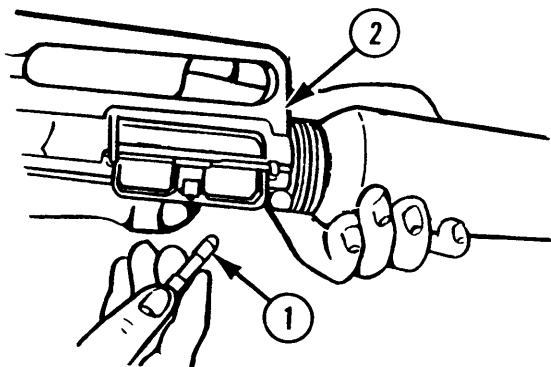

1 HEADSPACE GAGE (1). Insert in chamber of upper receiver and barrel assembly (2).

2 BOLT CARRIER AND STRIKER ASSEMBLY (3). Insert into upper receiver and barrel assembly (2).

3 BOLT CARRIER AND STRIKER ASSEMBLY (3) AND CHARGING HANDLE ASSEMBLY (4). Press forward using light finger pressure.

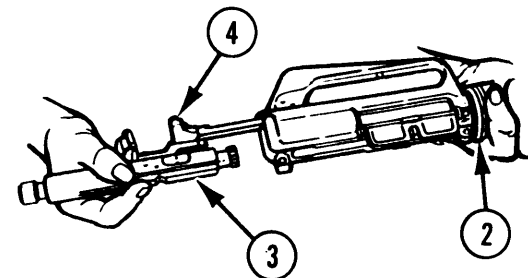
**NOTE**

If firing hammer is flush with rear of upper receiver (5) and/or the bolt carrier and striker assembly closes and locks, the barrel and extension assembly or breech bolt is unserviceable.

4 BOLT CARRIER AND STRIKER ASSEMBLY (3) AND HEADSPACE GAGE (1). Remove.

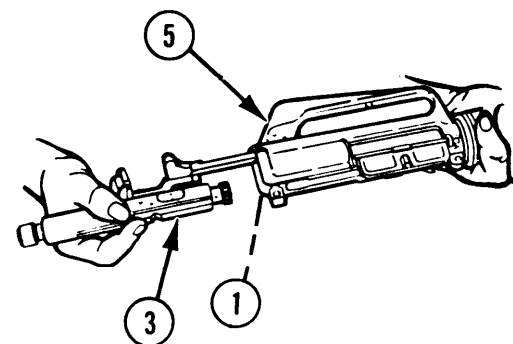

### 3-9. UPPER RECEIVER ASSEMBLY--MAINTENANCE INSTRUCTIONS

#### THIS TASK COVERS:

- a. Disassembly
- b. Inspection/cleaning
- c. Repair
- d. Reassembly

#### INITIAL SETUP

##### Tools and Special Tools

Small arms repairman tool kit (SC 5180-95-CL-A07)

##### Materials/Parts

Abrasive cloth (item 9, app D)  
Dry cleaning solvent (item 10, app D)  
Protective gloves (item 10.1, app D)  
Solid film lubricant (item 13, app D)  
Wiping rag (item 18, app D)

##### Personnel Required

MOS 45B-10 Small arms repairer

##### References

Appendix C  
Appendix D

##### Equipment Conditions

3-28 Upper receiver assembly removed from upper receiver and barrel assembly

#### DISASSEMBLY

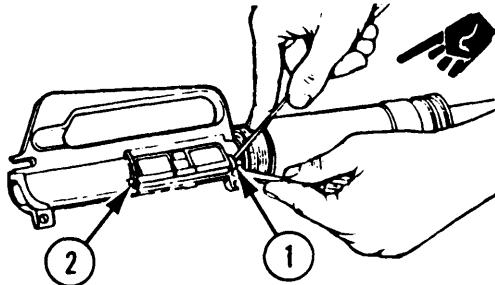

- 1 RETAINING RING (1). Use two small screwdrivers as shown to remove retaining ring (1) from ejection port cover pin (2).

#### WARNING

Be careful when removing spring loaded parts. Carelessness could result in injury.

- 2 EJECTION PORT COVER PIN (2). Pull out of upper receiver (3).
- 3 HELICAL TORSION SPRING (4) AND EJECTION PORT COVER (5). Remove.

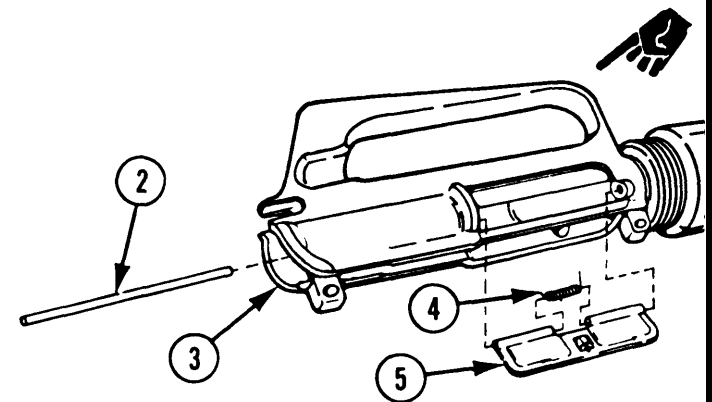

## 3-9. UPPER RECEIVER ASSEMBLY--MAINTENANCE INSTRUCTIONS (cont)

## INSPECTION/CLEANING

## 1 ALL PARTS.

- a. Wipe off with wiping rag (item 18, app D).
- b. Inspect for wear, damage, and burrs.
- c. If present, remove burrs with a stone or file.

## 2 UPPER RECEIVER. Check for cracks, corrosion, damaged threads, and mutilation.

## REPAIR

## 1 UPPER RECEIVER.

- a. Sand corroded external surfaces and small gouge areas with abrasive cloth (item 9, app D).

**WARNING**

- Dry cleaning solvent (SD) (A-A-711) is flammable and should not be used near an open flame or in a smoking area. Use only in well-ventilated areas. This solvent evaporates quickly and has a drying effect on the skin. Use of gloves (item 10.1, app D) is necessary to protect the skin. When used without gloves it may cause cracks in the skin and in some cases mild irritation or inflammation.

- b. Clean with dry cleaning solvent (item 10, app D).

**WARNING**

When using solid film lubricant, be sure area is well-ventilated.

**CAUTION**

Be sure upper receiver is thoroughly cleaned and dried prior to application of solid film lubricant.

Solid film lubricant is to be used only as an exterior surface protective finish and touchup. If solid film lubricant comes in contact with recoiling parts or functional surfaces of the M231 submachine gun, remove immediately by cleaning with dry cleaning solvent (item 10, app D).

**NOTE**

If one-third or more of the exterior protective finish is missing, evacuate the weapon to depot for overhaul. Application of phosphate finish to this weapon is not authorized below depot level.

- c. Spray a coat of solid film lubricant (item 13, app D) on all shiny external surfaces.
- d. Allow solid film lubricant to dry 24 hours before reassembly.

## 2 ALL PARTS. Repair is by replacement of authorized parts (app C) as required.

## REASSEMBLY

- 1 EJECTION PORT COVER (1). Position on upper receiver (2) and hold in place.
- 2 EJECTION PORT COVER PIN (3). Install through upper receiver (2) and ejection port cover (1) up to spring opening!
- 3 HELICAL TORSION SPRING (4). Put in place with long end toward the front of the upper receiver.
- 4 EJECTION PORT COVER PIN (3). Insert halfway into helical torsion spring (4).
- 5 HELICAL TORSION SPRING (4). Twist long end of spring one full turn to the right.
- 6 EJECTION PORT COVER PIN (3). Insert all the way and release helical torsion spring (4).
- 7 RETAINING RING (5). Install on ejection port cover pin (3) using small screwdriver.

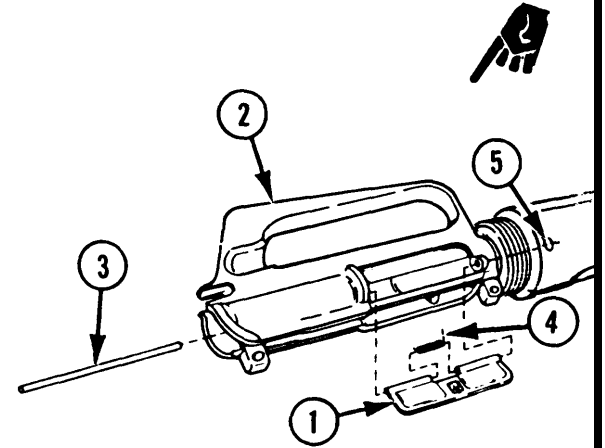

## 3-10. BARREL NUT ASSEMBLY--MAINTENANCE INSTRUCTIONS

### THIS TASK COVERS:

- |                |               |
|----------------|---------------|
| a. Disassembly | d. Repair     |
| b. Cleaning    | e. Reassembly |
| c. Inspection  |               |

### INITIAL SETUP

#### Tools and Special Tools

Small arms repairman tool kit (SC 5180-95-CL-A07)

#### Materials/Parts

- Dry cleaning solvent (item 10, app D)
- Protective gloves (item 10.1, app D)

#### Personnel Required

MOS 45B-10 Small arms repairer

#### References

- Appendix C
- Appendix D

#### Equipment Conditions

- 3-28 Barrel nut assembly removed from upper receiver and barrel assembly

3-10. BARREL NUT ASSEMBLY--MAINTENANCE INSTRUCTIONS (cont)

**DISASSEMBLY**

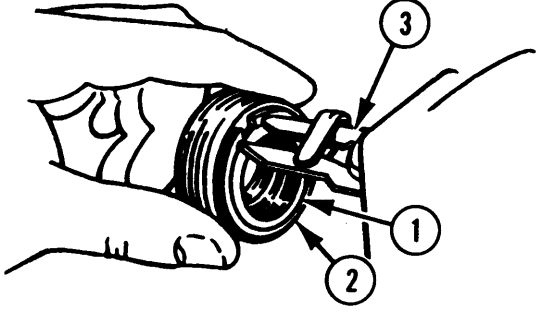

1 RETAINING RING (1). Remove from barrel nut (2) using retaining ring pliers (3).

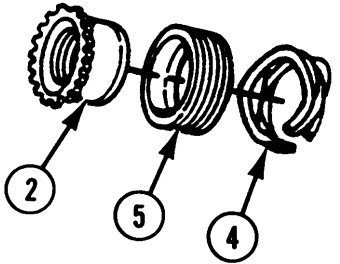

2 SLIP RING SPRING (4) AND HAND-GUARD SLIP RING (5). Remove from barrel nut (2).

**CLEANING**

**WARNING**

Dry cleaning solvent (SD) (A-A-711) is flammable should not be used near an open flame or in a sinking area. Use only in well-ventilated areas. This solvent evaporates quickly and has drying effect on the skin. Use of gloves (item 10.1, app D) is necessary to protect the skin. When used without gloves it may cause cracks in the skin and in some cases mild irritation or inflammation.

**INSPECTION**

ALL PARTS. Clean with dry cleaning solvent (item 10, app D).

BARREL NUT ASSEMBLY. Check for broken spring or damaged parts.

**REPAIR**

Repair is by replacement of authorized parts (app C) as required.

## REASSEMBLY

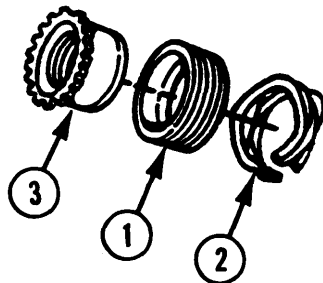

1 HANDGUARD SLIP RING (1) AND SLIP RING SPRING (2). Slide onto barrel nut (3).

### NOTE

Seat retaining ring on groove of barrel nut.

2 RETAINING RING (4). Lock in place on barrel nut (3) using retaining ring pliers (5).

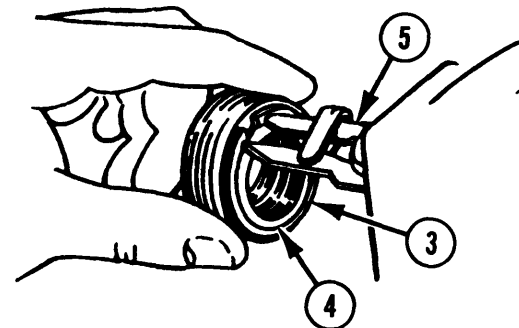

## 3-11. BARREL AND BARREL COLLAR ASSEMBLY--MAINTENANCE INSTRUCTIONS

### THIS TASK COVERS:

- a. Inspection
- b. Repair/replacement

- c. Reassembly/installation
- d. Test

### INITIAL SETUP

#### Tools and Special Tools

Small arms repairman tool kit (SC 5180-95-CL-A07)  
Small arms shop set (SC 4933-95-CL-A11)  
Number 51 drill bit

#### Personnel Required

MOS 45B-10 Small arms repairer

#### References

3-33 Reassembly of upper receiver and barrel assembly

3-32 Chamber test  
3-33 Barrel straightness test  
3-37 Barrel erosion test  
3-38 Headspace test  
Appendix C

#### Equipment Conditions

2-15 Upper receiver and barrel assembly removed  
3-26 Barrel and barrel collar assembly disassembled and removed

## 3-11. BARREL AND BARREL COLLAR ASSEMBLY--MAINTENANCE INSTRUCTIONS (cont)

**INSPECTION**

## 1 ALL PARTS.

- a. Inspect for wear and damage.
- b. Inspect for burrs, paying particular attention to locking lug area of barrel and extension assembly.
- c. If present, remove burrs with a stone or file.

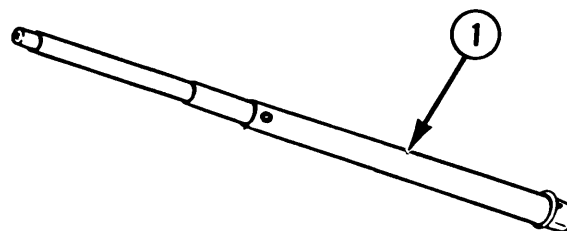

## 2 BARREL AND EXTENSION ASSEMBLY (1) .

- a. Inspect bore for cracks, rust, bulges, and pits.

**NOTE**

Pits in bore, no wider than a land or groove and no longer than 3/8 inch (0.953 cm), are allowed. Lands that appear dark due to coating of gilding metal from projectiles are allowable. Definitely ringed bores or bores ringed sufficiently to bulge the outside surface of the barrel and extension assembly are cause for rejection.

**REPAIR/REPLACEMENT**

- b. Inspect gas port (2) for carbon buildup.

**CAUTION**

Do not remove steel from gas port when removing carbon buildup.

- c. Remove carbon from gas port with a hand held no. 51, 0.067-in. drill bit.

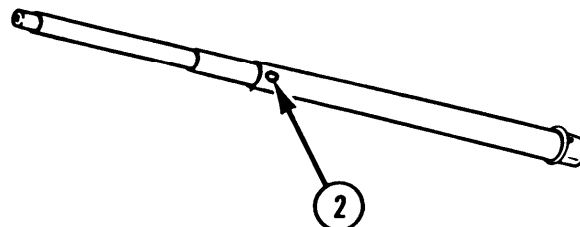

Repair is by replacement of authorized parts (app C) as required.

**REASSEMBLY/INSTALLATION****TEST****NOTE**

For reassembly/installation procedures of the barrel and barrel collar assembly, refer to the reassembly of the upper receiver and barrel assembly (p 3-33).

Perform four tests on the barrel and extension assembly to determine if it is serviceable or not. The tests are chamber test (p 3-32), barrel straightness test (p 3-33), barrel erosion test (p 3-37), and headspace test (p 3-38).

**3-12. LOWER RECEIVER AND RECEIVER EXTENSION ASSEMBLY--MAINTENANCE INSTRUCTIONS****THIS TASK COVERS:**

- |                |               |
|----------------|---------------|
| a. Disassembly | d. Repair     |
| b. Inspection  | e. Reassembly |
| c. Test        | f. Test       |

**INITIAL SETUP****Tools and Special Tools**

Small arms repairman tool kit (SC 5180-95-CL-A07)  
 Small arms shop set (SC 4933-95-CL-A07)  
 1-inch socket  
 1/2-inch drive handle socket wrench  
 1/2-inch drive torque wrench  
 Tool and gage set (fig. 11, app C)

**Materials/Parts**

Abrasive cloth (item 9, app D)  
 Dry cleaning solvent (item 10, app D)  
 Lubricating oil (LSA) (item 16, app D)  
 Molybdenum disulfide grease (item 11, app D)

Protective gloves (item 10.1, app D)  
 Solid film lubricant (item 13, app D)

**Personnel Required**

MOS 45B-10 Small arms repairer  
 Helper

**References**

Appendix C  
 Appendix D  
 Appendix E

**Equipment Conditions**

2-15 Lower receiver and receiver extension removed

3-12. LOWER RECEIVER AND RECEIVER EXTENSION ASSEMBLY--MAINTENANCE INSTRUCTIONS (cont.)

DISASSEMBLY

- 1 MACHINE SCREW (1), LOCKWASHER (2), AND RIFLE GRIP (3). Remove from lower receiver (4).

**NOTE**

Catch small parts to prevent loss.

- 2 HELICAL COMPRESSION SPRING (5) AND SAFETY DETENT (6). Remove.

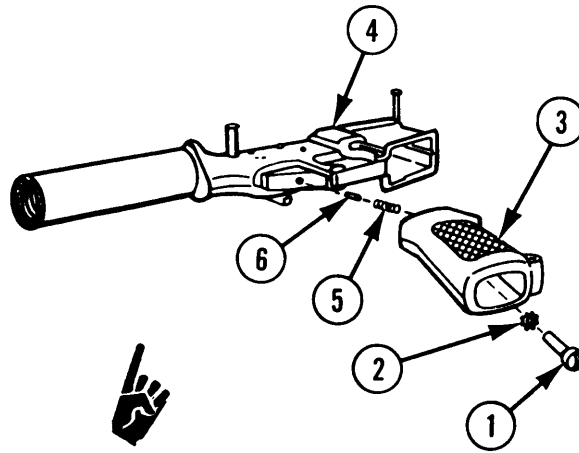

■ Art deleted.

3 ■ Deleted.

■ Art deleted.

4 ■ Deleted.

5 ■ Deleted.

■ Art deleted.

6 ■ Deleted.

**CAUTION**

Secure solid portion of lower receiver in vise to prevent damage.

7 LOWER RECEIVER (4) WITH ATTACHED PARTS. Place in vise with vise jaw caps as shown.

**NOTE**

Two soldiers are required to perform removal of receiver extension. A helper to steady lower receiver and a repairer to remove receiver extension.

8 RECEIVER EXTENSION (7). Remove from liner receiver (4) using receiver extension wrench (8), 1-inch socket and 1/2-inch drive handle socket wrench (9), and 3/16-inch punch (10).

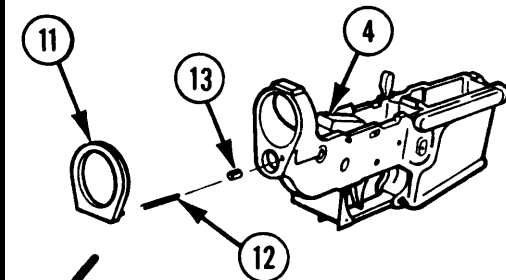
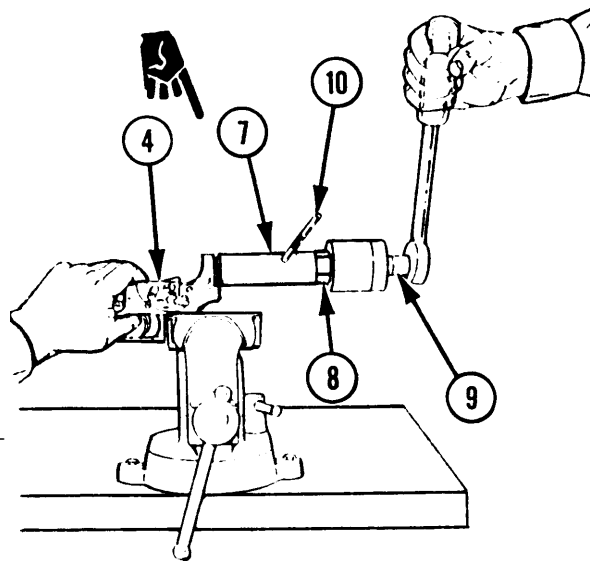

**NOTE**

Catch small parts to prevent loss.

9 ■ SPRING REAINER PLATE (11), HELICAL COMPRESSION SPRING (12), AND TAKE-DOWN PIN DETENT (13). Remove from lower receiver (4).

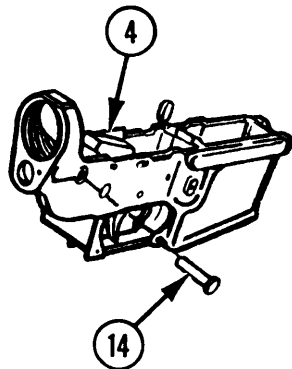

10 TAKEDOWN PIN (14). Remove from lower receiver (4).

11 PIN RETAINER (15). Pivot upward until head of headed straight pin (16) is visible.

12 HEADED STRAIGHT PIN (16). Remove by holding down on sear (17).

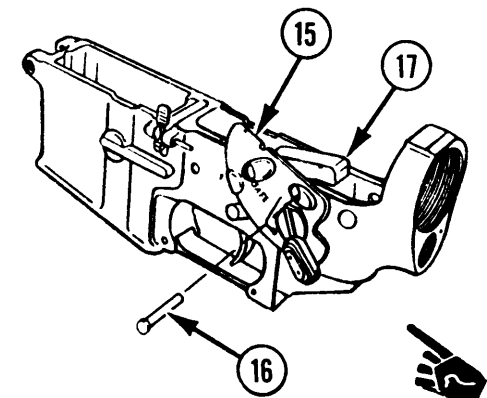

## 3-12. LOWER RECEIVER AND RECEIVER EXTENSION ASSEMBLY--MAINTENANCE INSTRUCTIONS (cont)

## DISASSEMBLY (cont)

13 HEADED STRAIGHT PIN (18). Remove.

14 SEAR (17) AND HELICAL SEAR SPRING (19). Remove from liner receiver (4).

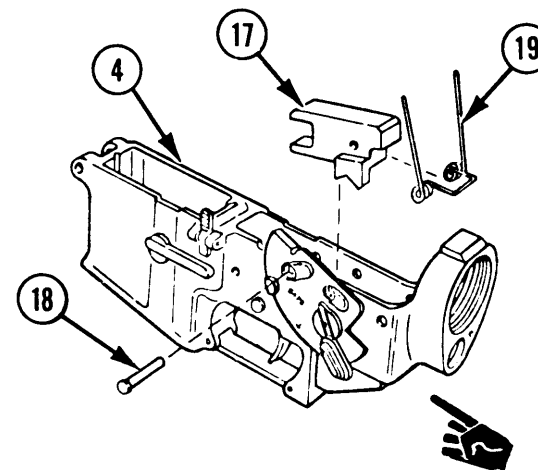

## NOTE

15 SELECTOR EVER (20) AND PIN RETAINER (15). Pull to remove from lower receiver (4).

16 HEADED STRAIGHT PIN (21). Push out of liner receiver (4) using 1/16-inch punch.

17 TRIGGER (22) AND HELICAL TORSION SPRING (23). Remove and separate.

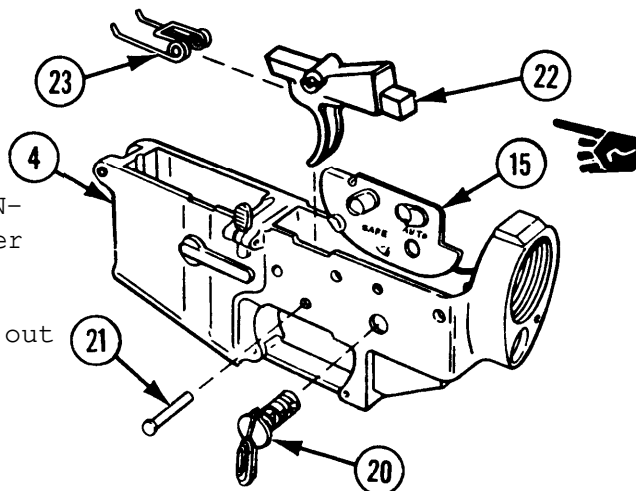

18 SPRING PIN (24). Drive out of lower receiver (4) using a 1/16-inch punch.

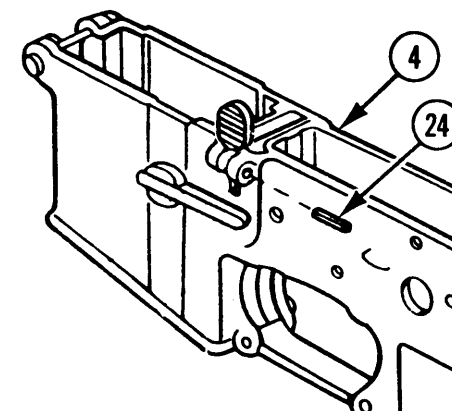

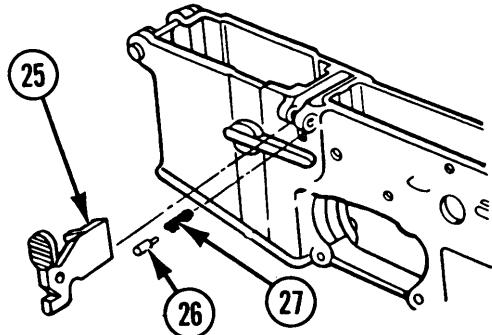

NOTE  
Catch small parts to prevent loss.

19 BOLT CATCH (25), BOLT CATCH PLUNGER (26), AND HELICAL COMPRESSION SPRING (27). Remove.

20 MAGAZINE CATCH BUTTON (28). Press with a 1/8-inch punch to expose magazine catch (29).

21 MAGAZINE CATCH (29). Unscrew to remove from lower receiver (4).

**NOTE**

Catch small parts to prevent loss.

22 MAGAZINE CATCH BUTTON (28) AND HELICAL COMPRESSION SPRING (30). Remove.

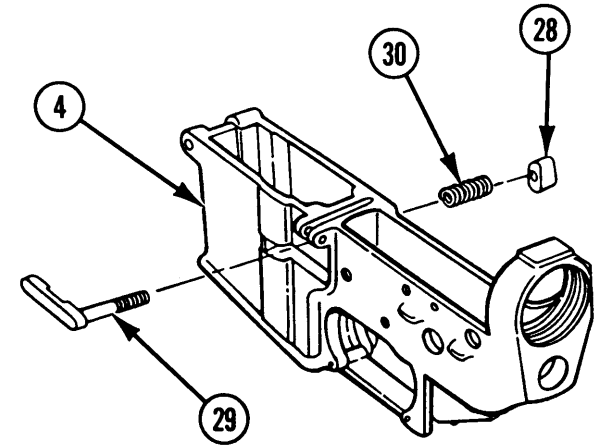

**INSPECTION**

23 TRIGGER GUARD (31). Depress pin (32) using 1/16-inch punch and swing down.

24 SPRING PIN (33). Remove using a 1/8-inch punch.

25 TRIGGER GUARD (31) 1 Remove.

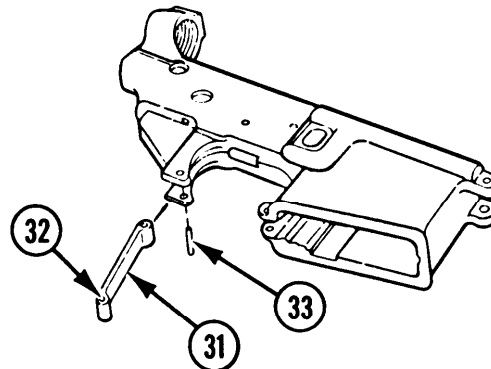

1 ■ Deleted.

2 ■ Deleted.

3 ALL SPRINGS AND SPRING PINS. Inspect for rust, breaks, and deformation.

## 3-12. LOWER RECEIVER AND RECEIVER EXTENSION ASSEMBLY--MAINTENANCE INSTRUCTIONS (cont)

**INSPECTION (cont)**

## 4 LOWER RECEIVER.

**NOTE**

Extensive corrosion in pivot pin area is cause for replacement.

- a. Check for cracks, corrosion, and mutilation.
- b. Inspect threads for damage.
- c. Inspect for burrs, remove with a stone or file if present.

## 5 ALL REMAINING PARTS.

- a. Check for wear, damage, and burrs.
- b. If present, remove burrs with a stone or file.

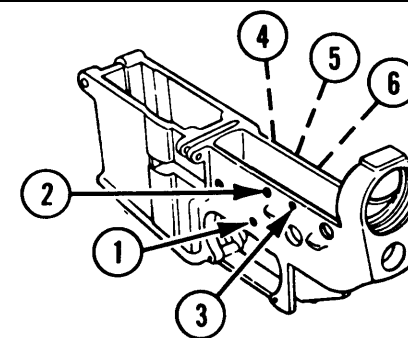
**TEST**

SIX HEADED STRAIGHT PIN HOLES (1 THRU 6). Check for oversize or out-of-round holes by performing the following procedures:

- a. Attempt to insert taper cylindrical (NOT GO) plug gage (7) by gage weight only, do not press.
- b. Rotate taper cylindrical (NOT GO) plug gage (7), rotational movement of the taper cylindrical (NOT GO) plug gage will determine both oversize and out-of-round holes.
- c. Entry of taper cylindrical (NOT GO) plug gage (7) in any headed straight pin hole (1 thru 6) is cause for replacement.

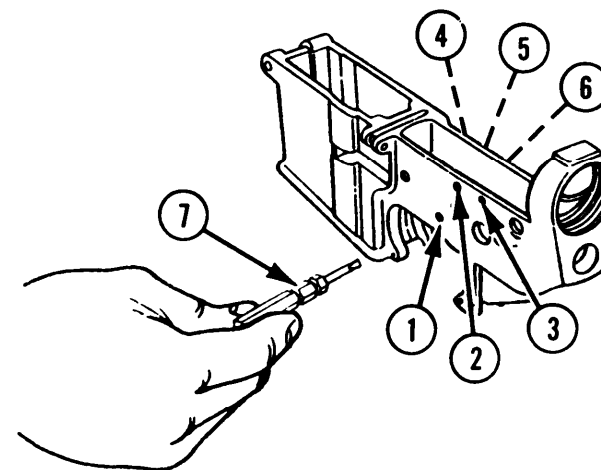

## REPAIR

### 1 LOWER RECEIVER.

#### WARNING

Dry cleaning solvent (SD), (A-A-711) is flammable and should not be used near an open flame or in a sinking area. Use only in well-ventilated areas. This solvent evaporates quickly and has a drying effect on the skin. Use of gloves (item 10.1, app D) is necessary to protect the skin. When used without gloves it may cause cracks in the skin and in some cases mild irritation or inflammation.

- a. Clean with dry cleaning solvent (item 10, app D).
- b. Sand corroded areas with abrasive cloth (item 9, app D).

#### WARNING

When using solid film lubricant, be sure area is well-ventilated.

Dry cleaning solvent (SD) (A-A-711) is flammable and should not be used near an open flame or in a sinking area. Use only in well-ventilated areas. This solvent evaporates quickly and has a drying effect on the skin. Use of gloves (item 10.1, app D) is necessary to protect the skin. When used without gloves it may cause cracks in the skin and in some cases mild irritation or inflammation.

#### CAUTION

Be sure lower receiver is thoroughly cleaned and dried prior to application of solid film lubricant.

Solid film lubricant is to be used only as an exterior surface protective finish and touchup. If solid film lubricant comes in contact with recoiling parts or functional surfaces of the weapon, remove immediately by washing with dry cleaning solvent (item 10, app D).

#### NOTE

If one-third or more of the exterior protective finish is missing, evacuate the weapon to depot for overhaul. Application of phosphate finish to this weapon is not authorized below depot level.

- c. Spray a coat of solid film lubricant (item 13, app D) on all shiny external surfaces.
- d. Allow solid film lubricant to dry 24 hours before reassembly.

2 ALL PARTS. Repair is by replacement of authorized parts (app C) as required.

## 3-12. LOWER RECEIVER AND RECEIVER EXTENSION ASSEMBLY--MAINTENANCE INSTRUCTIONS (cont)

## REASSEMBLY

## 1 TRIGGER GUARD (1).

- a. Position in lower receiver (2).
- b. Drive in spring pin (3) flush with surface of lower receiver (2).
- c. Swing trigger guard up, press pin (4) and lock in closed position.

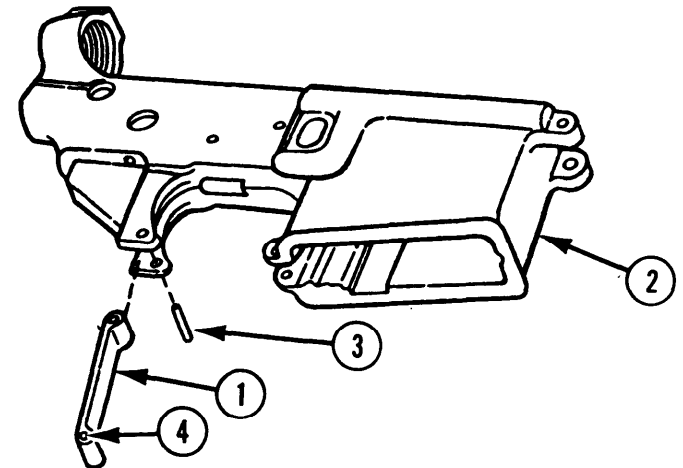

## 2 HELICAL COMPRESSION SPRING (5) AND MAGAZINE CATCH BUTTON (6).

- a. Generously lubricate helical compression spring (5) with lubricating oil (LSA) (item 16, app D).
- b. Position helical compression spring (5) and magazine catch button (6) in lower receiver (2) with ribbed side of magazine catch button (6) to outside.
- c. Compress magazine catch button (6) and helical compression spring with your thumb.

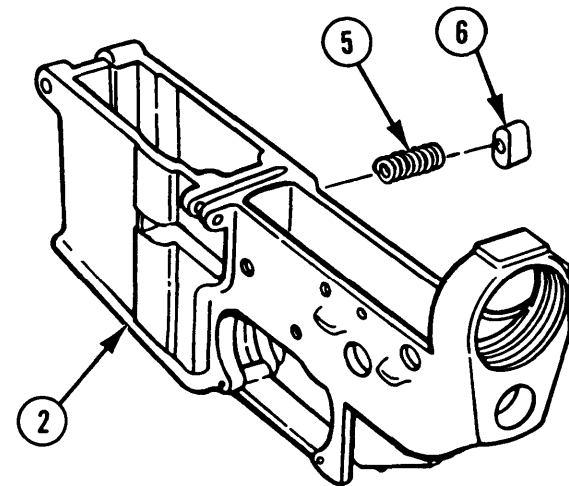

3 MAGAZINE CATCH (7).

- a. Start magazine catch (7) on to magazine catch button (6).
- b. Compress magazine catch button (6) and helical compression spring (5) using a punch.
- c. Continue screwing magazine catch (7) on to magazine catch button (6) until threads are flush with magazine catch button (6).

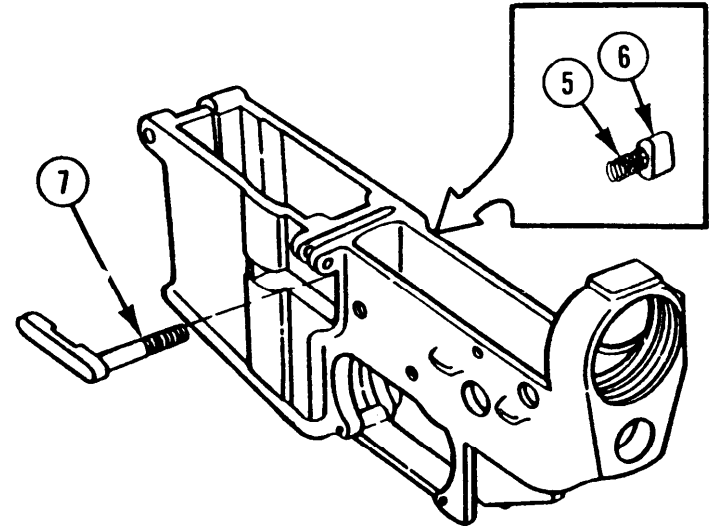

4 HELICAL COMPRESSION SPRING (8), BOLT CATCH PLUNGER (9), AND BOLT CATCH (10).

- a. Generously lubricate helical compression spring (8) with lubricating oil (LSA) (item 16, app D).
- b. Install helical compression spring (8) and bolt catch plunger (9) in lower receiver (2) and hold in place with finger.
- c. Align bolt catch (10) with groove in lower receiver (2) and press into place.
- d. Line up pin holes in bolt catch (10) and lower receiver.

5 SPRING PIN (11). Drive in flush with surface.

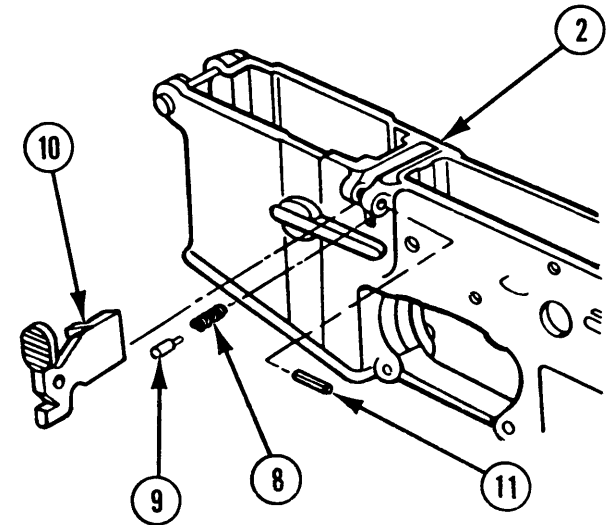

## 3-12. LOWER RECEIVER AND RECEIVER EXTENSION ASSEMBLY--MAINTENANCE INSTRUCTIONS (cont)

## REASSEMBLY (cont)

- 6 HELICAL TORSION SPRING (12) AND TRIGGER (13).
- Assemble together as illustrated, making sure helical torsion spring tails are in the direction shown.
  - Place inside lower receiver, alining holes with holes in lower receiver (2).
  - Hold in place.
- 7 HEADED STRAIGHT PIN (14). Install.
- 8 PIN RETAINER (15). Position on outside of lower receiver (2).

**NOTE**

Selector lever is not interchangeable with selector lever from M16A1 rifle.

- 9 SELECTOR LEVER (16). Install through pin retainer (15) into lower receiver (2).

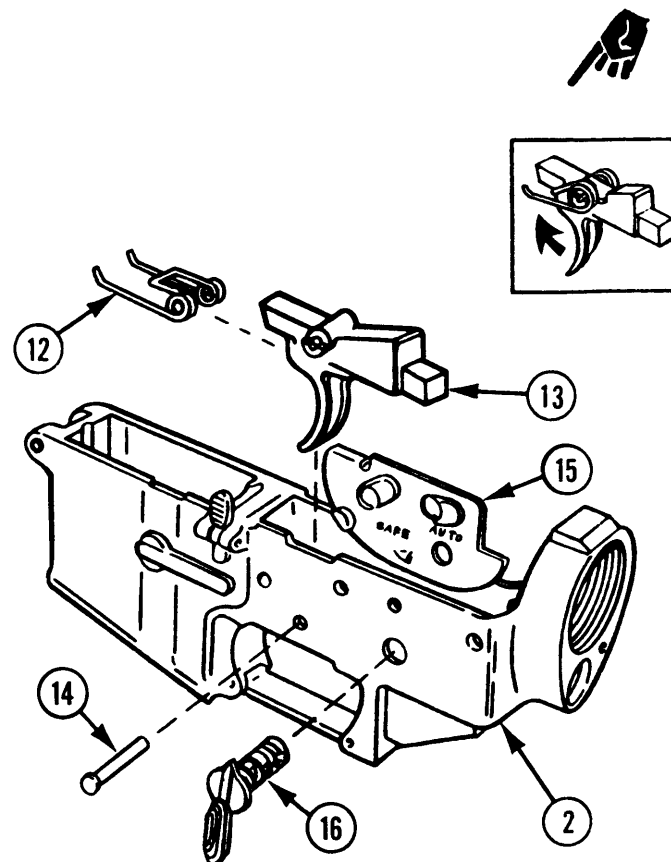

10 HELICAL SEAR SPRING (17) AND SEAR (18).

- a. Aline sear (18) with holes in helical sear spring (17), tails of helical sear spring will be extending up from lower receiver (2).
- b. Install in lower receiver.

11 HEADED STRAIGHT PIN (19). Pivot pin retainer (15) upward and install through side of liner receiver (2) and holes in helical sear spring (17).

12 HELICAL SEAR SPRING (17). Push tails down and hold in place by installing headed straight pin (20) over tails and through end of sear (18).

13 PIN RETAINER (15).

- a. Pivot down to lock headed straight pins in place.
- b. Put selector lever to SAFE.

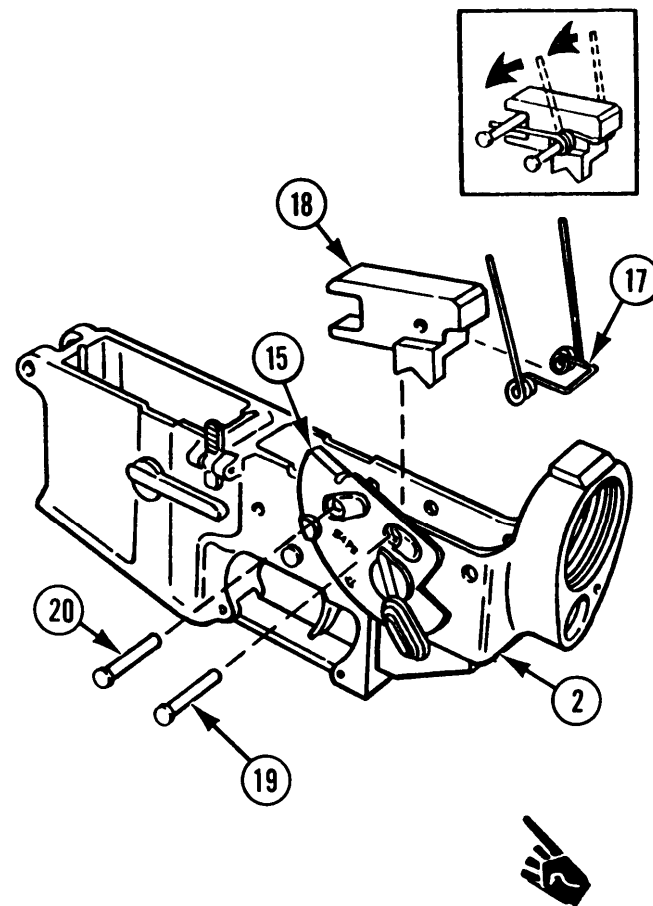

## 3-12. LOWER RECEIVER AND RECEIVER EXTENSION ASSEMBLY--MAINTENANCE INSTRUCTIONS (cont)

## REASSEMBLY (cont)

14 LOWER RECEIVER (2) WITH ATTACHED PARTS. Place in vise jaw caps.

15 TAKEDOWN PIN (21). Install.

**NOTE**

Be sure that the groove of the takedown pin faces to the rear.

16 TAKEDOWN PIN DETENT (22) AND HELICAL COMPRESSION SPRING (23). Generously lubricate with lubricating oil (LSA) (item 16, app D) and install in lower receiver (2).

17 **■** SPRING RETAINER PLATE (24) AND RECEIVER EXTENSION (25).

- a. Apply molybdenum disulfide grease (item 11, app D) to threads of receiver extension (25).

**CAUTION**

Compress helical compression spring with **■** spring retainer plate to prevent damage.

- b. **■** Install spring retainer plate (24) by aligning bent portion (26) with hole in lower receiver (2) 1
- c. **■** While holding spring retainer plate (24) in place, install receiver extension (25) **■** through spring retainer plate (24) and screw into lower receiver (2).

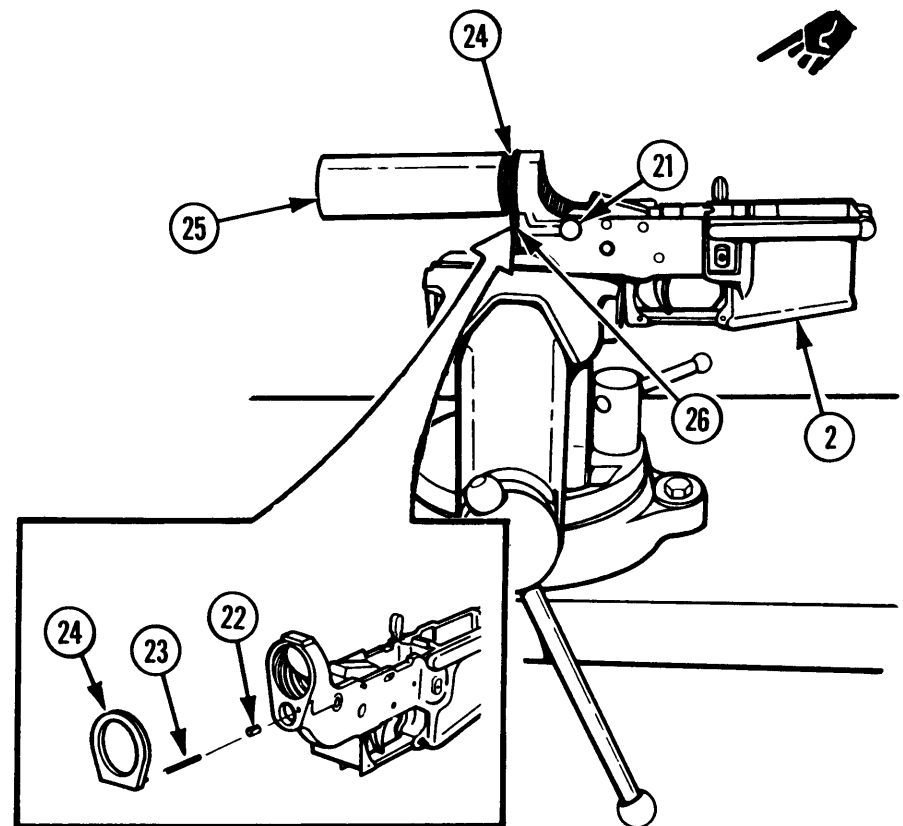

**NOTE**

Two soldiers are required to torque the receiver extension. A helper to steady lower receiver and a repairer to use the 1-inch socket and 1/2-inch drive torque wrench.

- 18 ■ RECEIVER EXTENSION (25). Tighten to 50 to 53 ft-lb (67.80 to 71.87 N·m) using receiver extension wrench (27), 1-inch socket and 1/2-inch drive torque wrench (28), and 3/16-inch punch (29).

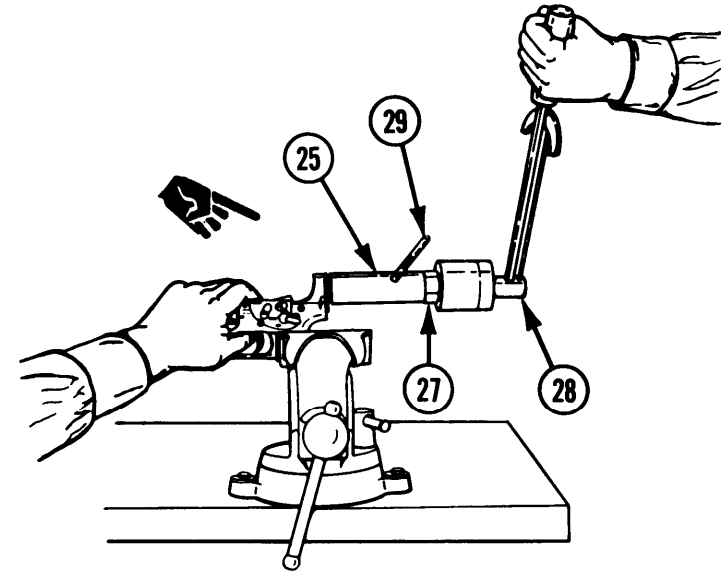

19 ■ Deleted.

■ Art deleted.

■ Art deleted.

20 ■ Deleted.

## 3-12. LOWER RECEIVER AND RECEIVER EXTENSION ASSEMBLY--MAINTENANCE INSTRUCTIONS (cont)

## REASSEMBLY (cont)

Art deleted.

21 Deleted.

22 SAFETY DETENT (30).

- a. Lightly lube with lubricating oil (LSA) (item 16, app D).
- b. Insert in lower receiver (2) with pointed end first.

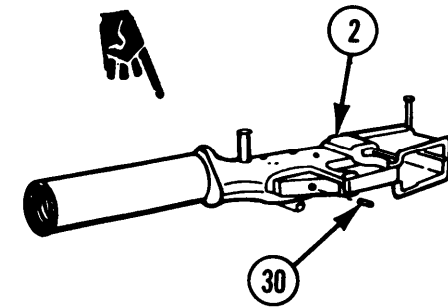

23 LOCKWASHER (31) AND MACHINE SCREW (32). Install in rifle grip (33).

24 HELICAL COMPRESSION SPRING (34).

**CAUTION**

Be careful not to damage helical compression spring.

**NOTE**

Turn rifle grip sideways for ease in installation.

- a. Install in rifle grip.
- b. Aline with lower receiver (2).

25 RIFLE GRIP (33). Install on lower receiver (2).

26 MACHINE SCREW (32). Tighten handtight.

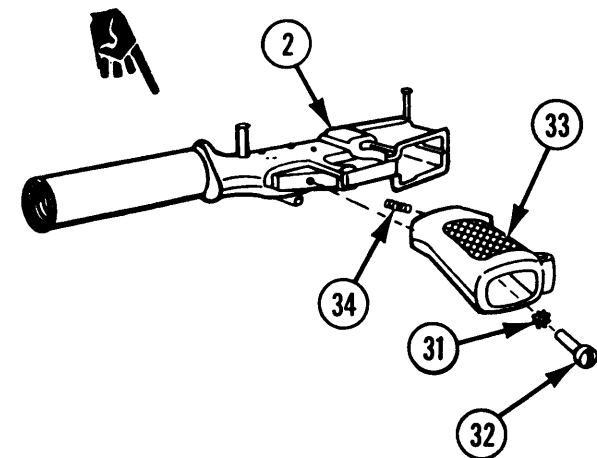

## Section III. PREPARATION FOR STORAGE OR SHIPMENT

### 3-13. CLEANING, PRESERVATION, PACKING, AND MARKING

Disassemble, clean, dry, preserve, and pack the M231 submachine gun as follows:

- a. Disassemble the M231 submachine gun as necessary to accomplish the cleaning.
- b. Clean all metallic surfaces with rifle bore cleaning compound (RBC) (item 8, app D) and dry with clean, dry wiping rags (item 18, app D). Clean non-metallic surfaces with clean, dry wiping rags (item 18, app D).
- c. Preserve all metallic surfaces of the M231 submachine gun with general purpose lubricating oil (item 14, app D).

### 3-14. UNIT PACK

Remove cartridge magazine and insert into a bag (TM 9-1005-309-10). Close bag by heat sealing, stapling, or taping.

- b. Overwrap the M231 submachine gun with VCI treated material (item 17, app D). If VCI treated material is not available, use barrier material (item 1, app D). Secure wrap with tape (item 21, app D). Insert wrapped weapon in tubing (item 0.1, app D) and heat seal, staple, or tape.
- c. Place wrapped M231 submachine gun into fiberboard box (item 4, app D). Use cushioning material (items 16.1 and 16.2, app D) and tape (item 23, app D) as required to immobilize items within container.
- d. Place cartridge magazine into the Void area of fiberboard box. Seal fiberboard box with pressure sensitive tape (item 22, app D). Seal all seams and joints.

### 3-15. APPLYING MARKING

Apply the following marking on each fiberboard box:

NATIONAL STOCK NUMBER  
FEDERAL ITEM NAME  
1 EACH  
DATE (MONTH, YEAR)  
WEIGHT:                      CUBE :

b. Place a quantity of packaged M231 submachine guns into a shipping box (item 2 or item 3, app D) according to the weight limitations of either shipping box used.

c. Use blocking as required to immobilize packaged M231 submachine guns within wooden box.

d. Nail top to wooden box.

Secure shipping box with strapping (item 19, app D).

f. Omit the following marking from exterior of wooden box:

NATIONAL STOCK NUMBER  
FEDERAL ITEM NAME  
LIST OF SERIAL NUMBERS  
PACKING LIST

g. Apply only the following markings by stencil or label to exterior of wooden box:

ADDRESS OF DESTINATION  
WEIGHT AND CUBE

**PREPARATION FOR STORAGE OR SHIPMENT (Cont)****3-15.1 STORAGE**

a. The M12 Arms Rack is the correct arms rack in which to store the M231 Firing Port Weapon. When storing the M231 Firing Port Weapon in the M12 Arms Rack a Mounting Bracket, NSN 5210-01-230-3181, must be used for each M231 Firing Port Weapon being stored. This requirement is for the safety of the person that opens the arms rack as well as to prevent damage to the weapon when the rack is opened. Without the mounting bracket the M231 Firing Port Weapons can fall out of the rack when it is opened.

b. To install the mounting bracket on the M12 Arms Rack, for use with the M231 Firing Port Weapon, install the bracket with the hooks of the bracket facing toward the weapon, so that the lower receiver extension will contact the bent end of the bracket. The bent end of the bracket will hold the Firing Port Weapon upright when the arms rack is opened.

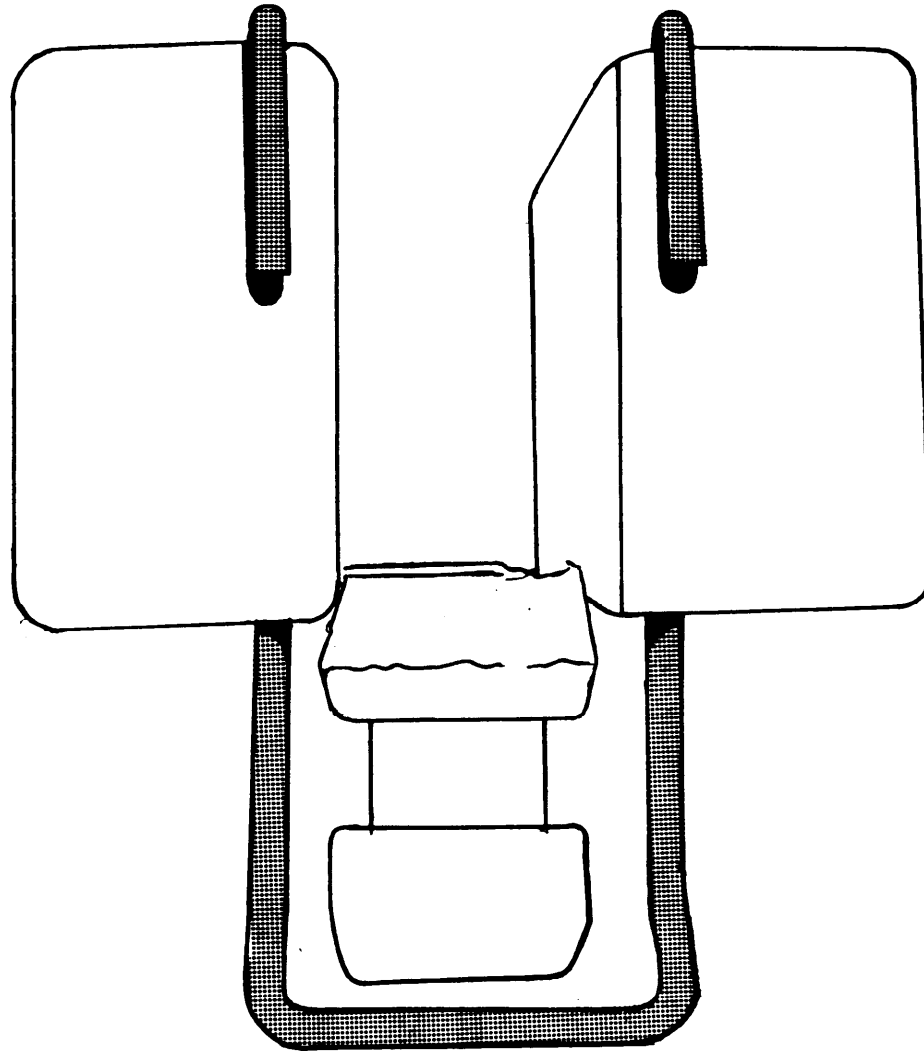

Mounting Bracket, P/N 12556036 (M231 Only)

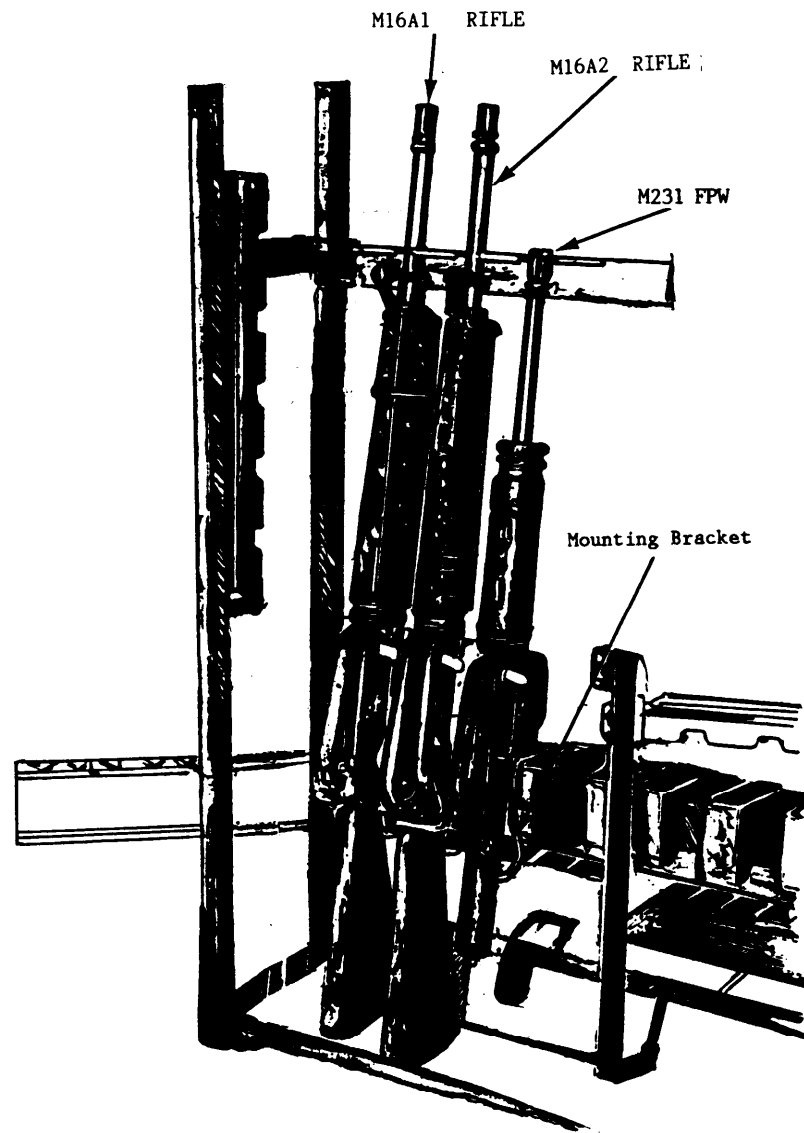

M12 Arms Rack (Storage of M231 FPW)

## Section IV. PREEMBARKATION INSPECTION OF MATERIEL IN UNITS ALERTED FOR OVERSEAS MOVEMENT

### 3-16. GENERAL

This inspection is conducted on materiel in units alerted for overseas duty to be sure that such materiel will not become unserviceable in a relatively short time. It prescribes a higher percentage of remaining usable life in serviceable materiel to meet the specific need beyond minimum serviceability.

### 3-17. PREINSPECTION POINTS

#### WARNING

Before starting an inspection, be sure to clear M231 submachine gun. Live ammunition should not be near the work area.

a. Before inspection, the materiel must be thoroughly cleaned of all grease, dirt, and other foreign matter that might interfere with its proper function or the use of gages and tools during inspection (TM 9-1005-309-10).

b. Materiel must be free of burrs, rust, and corrosion on functional surfaces.

c. Parts must not be cracked, bent, distorted, or damaged and must not be worn or loose.

d. Minor defects in metal parts do not normally affect their use. For example, scratches and tool marks are ordinarily of no importance.

Inspect finish on metal surfaces. Satisfactory metal surfaces for weapons range from black to light

gray. A shiny metal surface is objectionable when it is capable of reflecting light. Weapons will be rejected when exterior parts are shiny.

### 3-18. INSPECTION POINTS

a. Springs must be free of distortion and broken coils. Springs must have sufficient tension to perform their intended function.

b. Check barrel and extension assembly for the following:

- (1) Must be clean and free of rust and corrosion.
- (2) Must not be bulged.
- (3) May have small amounts of flaking or small cracks in the chrome plating in the chamber and bore.
- (4) Pits in the chamber are allowable if they do not cause extraction difficulties.
- (5) Scattered or uniformly fine pits, or fine pits in a densely pitted area, are allowable.
- (6) Tool marks are acceptable, regardless of length.
- (7) Lands that appear dark, due to coating of gilding metal from projectiles, will not be cause for rejection.

c. Flash suppressor must not be dented.

3-18. INSPECTION POINTS (cont)

positive cambering, extraction, and ejection action (TM 9-1005-309-10).

d. Each weapon must be hand functioned to check for no binding, positive cocking action, and general operation. Dummy ammunition may be used to be sure of

- e. Screws must be tight.
- f. All markings must be legible.

3-19. SPECIFIC STANDARDS

Table 3-2. STANDARDS FOR PREEMBARKATION INSPECTION IN UNITS ALERTED FOR OVERSEAS MOVEMENT

ITEM	STANDARD
------	----------

**NOTE**

Stripping of lands and grooves shall not be cause for rejection unless determined by barrel erosion gage.

Barrel and extension assembly . . . . . Check barrel erosion (p 3-37).

**NOTE**

Pits 1/8 inch (0.318 cm) in length and those pits large enough to extend from the body of the chamber into the shoulder stop area and forcing cone area are cause for rejection. Large pits are defined as those 1/8 inch (0.318 cm) or more in diameter and approximately 1/64 inch (0.041 cm) in depth, as determined by visual inspection.

Visually inspect chamber using chamber reflector tool (p 3-32).

Gas metallic bent tube . . . . . Inspect for cracks.

Bolt carrier and striker assembly . . . . . Inspect for elongated firing pin hole (p 3-27).

**NOTE**

Bolts that contain pits extending into the firing pin hole will not be rejected. Bolts that contain small, individual pits of a scattered pattern or group clusters of small pits shall not be cause for rejection. Refer to bolt inspection data (p 3-26).

Inspect each locking lug periodically for cracks, particular attention must be given to the area where the locking lug meets the bolt body.

Bolt rings must not be broken. Bolt ring gaps must be spaced and not in line.

Firing pin protrusion must be not less than 0.028 inch (0.071 cm) or more than 0.036 inch (0.091 cm). Refer to test procedure on page 3-24.

Headspace . . . . . Check for headspace, refer to page 3-13.

Trigger pull . . . . . Test trigger pull, refer to page 3-16.

Lower receiver and receiver extension assembly . . . . . Inspect for cracks, corrosion, and mutilation which would affect functioning. Small dents or gouges will not be cause for rejection.

Inspect lower receiver for corrosion in the lobes of the pivot or take-down pin area.

Inspect lower receiver for breakthrough of metal.

Inspect lower receiver for loss of protective coating.

Inspect for oversize or out-of-round headed straight pin holes (p 3-50).

Drive spring and guide assembly . . . . . Free length of helical compression springs is as follows:

	Maximum	Minimum
Outer	10 3/8 in. (26.4 cm)	9 5/8 in. (24.5 cm)
Middle	10 3/8 in. (26.4 cm)	9 5/8 in. (24.5 cm)
Inner	7 5/8 in. (19.4 cm)	7 1/8 in. (18.1 cm)



3-19. SPECIFIC STANDARDS (cont)

Table 3-2. STANDARDS FOR PREEMBARKATION INSPECTION  
IN UNITS ALERTED FOR OVERSEAS MOVEMENT (cont)

---

ITEM	STANDARD
Handguards .....	Inspect for cracks, breaks, separations of material, and loose liner rivets.
	Inspect for broken vent tabs. If two tabs are missing from either handguard, handguard is unserviceable.

---

# APPENDIX A REFERENCES

## A-1. TECHNICAL MANUALS (TM)

- TM 750-244-7 ..... Procedures for Destruction of Equipment in Federal Supply Classifications 1000, 1005, 1010, 1015, 1020, 1025, 1030, 1055, 1090 and 1095 to Prevent Enemy Use
- TM 9-1005-309-10 ..... Operator's Manual, Sub-machine Gun, 5.56-mm: Port, Firing, M231 (1005-01-081-4582)

## A-2. DEPARTMENT OF THE ARMY FORMS (DA Form)

- DA Form 2028 ..... Recommended Changes to Publications and Blank Forms
- DA Form 2028-2 ..... Recommended Changes to Equipment Technical Manuals
- DA Form 2404 ..... Equipment Inspection and Maintenance Worksheet

## A-3. SUPPLY CATALOGS (SC)

- SC 4933-95-CL-A11 ..... Shop Set, Small Arms: Field Maintenance, Basic Less Power

- SC 5180-95-CL-A07 ..... Tool Kit, Small Arms Repairman

## A-4. OTHER

- AR 700-42 ..... Classification, Reclassification, Maintenance, Issuance and Reporting of Maintenance Training Aircraft
- CTA 8-100 ..... Army Medical Department Expendable/Durable Items
- CTA 50-970 ..... Expendable/Durable Items (Except Medical, Class V, Repair Parts, and Heraldic Items)
- DA PAM 738-750 ..... The Army Maintenance Management System (TAMMS)
- SF 364 ..... Report of Discrepancy (ROD)
- FM 21-11 ..... First Aid for Soldiers
- SF 368 ..... Quality Deficiency Report



# APPENDIX B

## MAINTENANCE ALLOCATION CHART

---

### Section I. INTRODUCTION

#### **B-1. GENERAL**

a. This section provides a general explanation of all maintenance and repair functions authorized at various maintenance categories.

b. The Maintenance Allocation Chart (MAC) in section II designates overall responsibility for the performance of maintenance functions on the identified end item or component. The implementation of the maintenance functions upon the end item or component will be consistent with the assigned maintenance functions.

c. Section III lists the special tools and test equipment required for each maintenance function as referenced from section II.

d. Section IV contains supplemental instructions and explanatory notes for a particular maintenance function.

#### **B-2. MAINTENANCE FUNCTIONS**

Maintenance functions will be limited to and defined as follows: (except for ammunition MAC<sup>1</sup>).

<sup>1</sup>Exception is authorized for ammunition MAC to permit the redesignation/redefinition of maintenance function headings to more adequately identify ammunition maintenance functions. The heading designations and definitions will be included in the appropriate technical manual for each category of ammunition.

a. Inspect. To determine the serviceability of an item by comparing its physical, mechanical, and/or electrical characteristics with established standards through examination.

b. Test. To verify serviceability by measuring the mechanical or electrical characteristics of an item and comparing those characteristics with prescribed standards.

c. Service. Operations required periodically to keep an item in proper operating condition, i.e., to clean (includes decontaminate, when required), to preserve, to drain, to paint, or to replenish fuel, lubricants, chemical fluids, or gases.

d. Adjust. To maintain, within prescribed limits, by bringing into proper or exact position, or by setting the operating characteristics to specified parameters.

e. Align. To adjust specified variable elements of an item to bring about optimum or desired performance.

f. Calibrate. To determine and cause corrections to be made or to be adjusted on instruments or test, measuring, and diagnostic equipments used in precision measurement. Consists of comparisons of two instruments, one of which is a certified standard of known accuracy, to detect and adjust any discrepancy in the accuracy of the instrument being compared.

g. Install. The act of emplacing, seating, or fixing into position an item, part, or module (component or assembly) in a manner to allow the proper functioning of an equipment or system.

**B-2. MAINTENANCE FUNCTIONS (cont)**

h. Replace. The act of substituting a serviceable like type part, subassembly, or module (component or assembly) for an unserviceable counterpart.

i. Repair. The application of maintenance services<sup>2</sup> or other maintenance actions<sup>3</sup> to restore serviceability to an item by correcting specific damage, fault, malfunction, or failure in a part, subassembly, module (component or assembly), end item, or system.

j. Overhaul. That maintenance effort (service/action) necessary to restore an item to a completely serviceable/operational condition as prescribed by maintenance standards in appropriate technical publications (i.e., DMWR). Overhaul is normally the highest degree of maintenance performed by the Army. Overhaul does not normally return an item to like new condition.

k. Rebuild. Consists of those services/actions necessary for the restoration of unserviceable equipment to a like new condition in accordance with original manufacturing standards. Rebuild is the highest degree of materiel maintenance applied to Army equipment. The rebuild operation includes the act of returning to zero those age measurements (hours/miles, etc.) considered in classifying Army equipments/components.

<sup>2</sup>Services--inspect, test, service, adjust, align, calibrate, or replace.

<sup>3</sup>Actions--welding, grinding, riveting, straightening, facing, remachining, or resurfacing.

**B-3. EXPLANATION OF COLUMNS IN THE MAC, SECTION II**

a. Column 1, Group Number. Column 1 lists functional group code numbers, the purpose of which is to identify components, assemblies, subassemblies, and modules with the next higher assembly.

b. Column 2, Component/Assembly. Column 2 contains the names of components, assemblies, subassemblies, and modules for which maintenance is authorized.

c. Column 3, Maintenance Function. Column 3 lists the functions to be performed on the item listed in Column 2. (For detailed explanation of these functions, see paragraph B-2.)

d. Column 4, Maintenance Category. Column 4 specifies, by the listing of a work time figure in the appropriate subcolumn(s), the category of maintenance authorized to perform the function listed in Column 3. This figure represents the active time required to perform that maintenance function at the indicated category of maintenance. If the number or complexity of the tasks within the listed maintenance function vary at different maintenance categories, appropriate work time figures will be shown for each category. The work time figure represents the average time required to restore an item (assembly, subassembly, component, module, end item, or system) to a serviceable condition under typical field operating conditions. This time includes preparation time, troubleshooting time, and quality assurance/quality control time in addition to the time required to perform the specific tasks identified for the maintenance functions authorized in the maintenance allocation chart. The symbol designations for the various maintenance categories are as follows:

c ..... Operator or crew  
o ..... Organizational maintenance  
F ..... Direct support maintenance  
H ..... General support maintenance  
D ..... Depot maintenance

e. Column 5, Tools and Equipment. Column 5 specifies, by code, those common tool sets (not individual tools) and special tools, TMDE, and support equipment required to perform the designated function.

f. Column 6, Remarks. This column shall, when applicable, contain a letter code, in alphabetic order, which shall be keyed to the remarks contained in section IV.

b. Column 2, Maintenance Category. The lowest category of maintenance authorized to use the tool or test equipment.

c. Column 3, Nomenclature. Name or identification of the tool or test equipment.

d. Column 4, National Stock Number. The National stock number of the tool or test equipment.

e. Column 5, Tool Number. The manufacturer's part number.

---

B-4. EXPLANATION OF COLUMNS IN TOOL AND TEST EQUIPMENT REQUIREMENTS, SECTION III

---

a. Column 1, Reference Code. The tool and test equipment reference code correlates with a code used in the MAC, section II, Column 5.

## Section II. MAINTENANCE ALLOCATION CHART FOR M231 SUBMACHINE GUN

(1) GROUP NUMBER	(2) COMPONENT/ ASSEMBLY	(3) MAINTENANCE FUNCTION	(4) MAINTENANCE CATEGORY					(5) TOOLS AND EQPT	(6) REMARKS
			C	O	F	H	D		
00	SUBMACHINE GUN, 5.56-MM: PORT, FIRING, M231	Inspect	0.1	0.1	0.1			1, 2 2, 3	
		Test	0.1		0.1				
		Service	0.1						
		Install	0.1						
		Replace		0.1					
		Repair		0.1				1	
01	DRIVE SPRING AND GUIDE ASSEMBLY	Inspect	0.1	0.1	0.1			1, 2	
		Service	0.1	0.1					
		Replace			0.1				
		Repair		0.1	0.1		1, 2		
0101	RETAINER ASSEMBLY	Inspect	0.1	0.1	0.1			1, 2	
		Service	0.1	0.1					
		Replace			0.1				
		Repair		0.1	0.1		1, 2		
02	BOLT CARRIER AND STRIKER ASSEMBLY	Inspect	0.1	0.1	0.1			1, 2 3	
		Test			0.1				
		Service	0.1		0.1				
		Replace			0.2				
		Repair		0.1	0.2		1, 2		
0201	BREECH BOLT	Inspect	0.1	0.1	0.1			1, 2 3	
		Test			0.1				
		Service	0.1	0.1					
		Replace			0.1		2		
		Repair		0.2	0.2		1, 2		

03	UPPER RECEIVER AND BARREL ASSEMBLY	Inspect	0.1	0.2	0.1			1, 2	
		Test			0.2			3	
		Service	0.2		0.1				
		Replace			0.1				
0301	CHARGING HANDLE ASSEMBLY	Repair		0.4	0.5			2, 3	
		Inspect	0.1	0.1			1		
		Service	0.1						
		Replace		0.1			1		
0302	UPPER RECEIVER ASSEMBLY	Repair		0.1				1	
		Inspect	0.1	0.1	0.1		1, 2		
		Service		0.1					
		Replace			0.1				
0303	BARREL NUT ASSEMBLY	Repair		0.2	0.3			1, 2	
		Inspect					2		
		Service			0.1				
		Replace			0.1				
0304	BARREL AND BARREL COLLAR ASSEMBLY	Repair			0.1			2	
		Inspect	0.1		0.1		2		
		Test			0.1		3		
		Replace			0.3		2, 3		
04	LOWER RECEIVER AND RECEIVER EXTENSION ASSEMBLY	Repair			0.1			2, 3	
		Inspect	0.1	0.1	0.1		1, 2		
		Test			0.1		3		
		Service	0.1	0.1					
				0.3	0.1		1, 2, 3	B,C	
					0.5				

### Section III. TOOL AND TEST EQUIPMENT REQUIREMENTS FOR M231 SUBMACHINE GUN

TOOL OR TEST EQUIPMENT REF CODE	MAINTENANCE CATEGORY	NOMENCLATURE	NATIONAL/ NATO STOCK NUMBER	TOOL NUMBER
1	0	TOOL KIT, SMALL ARMS REPAIRMAN	4933-00-357-7770	SC 5180-95-CL- A07
2	F	SHOP SET, SMALL ARMS: Field Maintenance, Basic Less Power	4933-00-754-0664	SC 4933-95-CL- A11
3	F	TOOL AND GAGE SET	4933-00-056-7106	8426685

### Section IV. REMARKS

REFERENCE CODE	REMARKS
A	Tool, Key (fabricated)
B	Tool, Pivot Pin Removing (fabricated)
c	Lower receiver (part number 9327037) meets security requirements and is serialized for accountability purposes " Disposal is not authorized below depot.

# APPENDIX C

## ORGANIZATIONAL, DIRECT SUPPORT, AND GENERAL SUPPORT MAINTENANCE REPAIR PARTS AND SPECIAL TOOLS LIST

---

### Section I. INTRODUCTION

#### C-1. SCOPE

This RPSTL lists and authorizes spares and repair parts; special tools; special test, measurement, and diagnostic equipment (TMDE); and other special support equipment required for performance of organizational, direct support, and general support maintenance of the M231 submachine gun. It authorizes the requisitioning, issue, and disposition of spares, repair parts and special tools as indicated by the source, maintenance and recoverability (SMR) codes.

#### C-2. GENERAL

In addition to Section I, Introduction, this Repair Parts and Special Tools List is divided into the following sections:

a. Section II. Repair Parts List. A list of spares and repair parts authorized by this RPSTL for use in the performance of maintenance. The list also includes parts which must be removed for replacement of the authorized parts. Parts lists are composed of functional groups in ascending alphanumeric sequence, with the parts in each group listed in ascending figure and item number sequence. Bulk materials are listed by item name in FIG BULK at the end of the section. Repair parts kits or sets are listed separately in their own functional group within section II. Repair parts for repairable special tools are also listed in this section.

b. Section III. Special Tools List. A list of special tools, special TMDE, and other special support equipment authorized by this RPSTL (as indicated by Basis of Issue (BOI) information in DESCRIPTION AND USABLE ON CODE (UOC) column) for the performance of maintenance.

c. Section IV. National Stock Number and Part Number Index. A list, in National item identification number (NIIN) sequence, of all National stock numbered items appearing in the listing, followed by a list in alphanumeric sequence of all part numbers appearing in the listing. National stock numbers and part numbers are cross-referenced to each illustration figure and item number appearance.

#### C-3. EXPLANATION OF COLUMNS (SECTIONS II AND III)

a. Item No. (column (1)). Indicates the number used to identify items called out in the illustration.

C-3. EXPLANATION OF COLUMNS (SECTIONS II AND III) (cont)

b. SMR Code (Column (2)). The Source, Maintenance, and Recoverability (SMR) code is a 5-position code containing supply/requisitioning information, maintenance category authorization criteria, and disposition instruction, as shown in the following breakout:

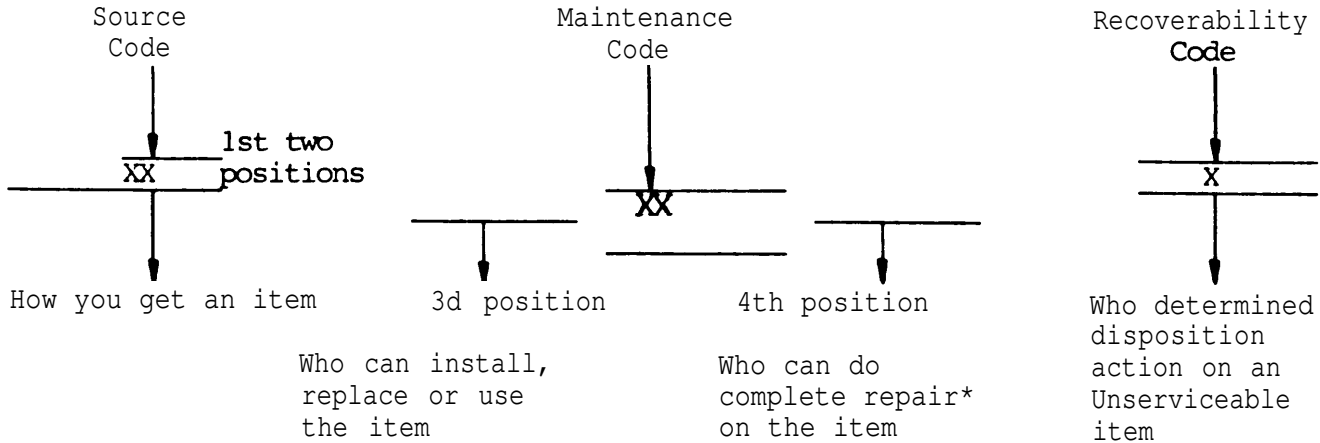

\*Complete Repair: Maintenance capacity, capability, and authority to perform all corrective maintenance tasks of the "Repair" function in a use/user environment in order to restore serviceability to a failed item.

(1) Source Code. The source code tells you how to get an item needed for maintenance, repair, or overhaul of an end item/equipment. Explanations of source codes follows:

Code	Explanation
PA PB PC** PD PE PF PG	Stocked items; use the applicable NSN to request/requisition items with these source codes. They are authorized to the category indicated by the code entered in the 3d position of the SMR code.  **NOTE: Item coded PC are subject to deterioration.
KD KF KB	Items with these codes are not to be requested/requisitioned individually. They are part of a kit which is authorized to the maintenance category indicated in the 3d position of the SMR code. The complete kit must be requisitioned and applied.

Code	Explanation
<p>MO- (Made at org/ AVUM Level) MF- (Made at DS/ AVUM Level) MH - (Made at GS Level) ML- (Made at Spe- cialized Repair Act (SRA)) MD - (Made at Depot)</p>	<p>Items with these codes are not to be requested/requisitioned individually. They must be made from bulk material which is identified by the part number in the DESCRIPTION AND USABLE ON CODE (UOC) column and listed in the bulk material group of the repair parts list in this RPSTL. If the item is authorized to you by the 3d position code of the SMR code, but the source code indicates it is made at a higher level, order the item from the higher level of maintenance.</p>

<p>AO - (Assembled by org/AVUM Level) AF - (Assembled by DS/AVIM Level) AH- (Assembled by GS category) AL - (Assembled by SRA) AD- (Assembled by Depot)</p>	<p>Items with these codes are not to be requested/requisitioned individually. The parts that make up the assembled item must be requisitioned or fabricated and assembled at the level of maintenance indicated by the source code. If the 3d position code of the SMR code authorizes you to replace the item, but the source code indicates the item is assembled at a higher level, order the item from the higher level of maintenance.</p>
---	---

- XA- Do not requisition an "XA"-coded item. Order its next higher assembly. (Also, refer to the NOTE below.)
- XB- If an "XB" item is not available from salvage, order it using the FSCM and part number given.
- xc - Installation drawing, diagram, instruction sheet, field service drawing, that is identified by manufacturer's part number.
- XD- Item is not stocked. Order an "XD"-coded item through normal supply channels using the FSCM and part number given, if no NSN is available.

NOTE: Cannibalization or controlled exchange, when authorized, may be used as a source of supply for items with the above source codes, except for those source coded "XA" or those aircraft support items restricted by requirements of AR 700-42.

C-3. EXPLANATION OF COLUMNS (SSECTIONS II AND III) (cont)

(2) Maintenance Code. Maintenance males tell you the level(s) of maintenance authorized to USE and REPAIR support items. The maintenance codes are entered in the third and fourth positions of the SMR Code as follows:

(a) The maintenance code entered in the third position tells you the lowest maintenance level authorized to remove, replace, and use an item. The maintenance code entered in the third position will indicate authorization to one of the following levels of maintenance.

Code	Application/Explanation
C	-Crew or operator maintenance done within organizational or aviation unit maintenance.
O	-organizational or aviation unit category can remove, replace, and use the item.
F	-Direct support or aviation intermediate level can remove, replace, and use the item.
H	-General support level can remove, replace, and use the item.
L	-Specialized repair activity can remove, replace, and use the item.
D	-Depot level can remove, replace, and use the item.

(b) The maintenance code entered in the fourth position tells whether or not the item is to be repaired and identifies the lowest maintenance level with the capability to do complete repair (i.e., perform all authorized repair functions).

(NOTE: Some limited repair may be done on the item at a lower level of maintenance, if authorized by the Maintenance Allocation Chart (MAC) and SMR codes.) This position will contain one of the following maintenance codes.

Code	Application/Explanation
O	-Organizational or aviation unit is the lowest level that can do complete repair of the item.
F	-Direct support or aviation intermediate is the lowest level that can do complete repair of the item.
H	-General support is the lowest level that can do complete repair of the item.

Code	Application/Explanation
L	-Specialized repair activity is the lowest level that can do complete repair of the item.
D	-Depot is the lowest level that can do complete repair of the item.
Z	-Nonreparable. No repair is authorized.
B	-No repair is authorized. (No parts or special tools are authorized for the maintenance of a "B" coded item.) However, the item may be reconditioned by adjusting, lubricating, etc. at the user level.

(3) Recoverability Code. Recoverability codes are assigned to items to indicate the disposition action on Unserviceable items. The recoverability code is entered in the fifth position of the SMR Code as follows:

Recoverability Codes	Application/Explanation
Z	-Nonreparable item. When unserviceable, condemn and dispose of the item at the level of maintenance shown in 3d position of SMR Code.
O	-Reparable item. When uneconomically repairable, condemn and dispose of the item at organizational or aviation unit level.
F	-Reparable item. When uneconomically repairable, condemn and dispose of the item at the direct support or aviation intermediate level.
H	-Reparable its. When uneconomically repairable, condemn and dispose of the item at the general support level.
D	-Reparable item. When beyond lower level repair capability, return to depot. Condemnation and disposal of item not authorized below depot level.
L	-Reparable item. Condemnation and disposal not authorized below specialized repair activity (SRA).
A	-Item requires special handling or condemnation procedures because of specific reasons (e.g., precious metal content, high dollar value, critical material, or hazardous material). Refer to appropriate manuals/directives for specific instruction.

C-3. EXPLANATION OF COLUMNS (SECTIONS II AND III) (cont)

c. FSCM (column (3)). The Federal Supply Code for Manufacturer (FSCM) is a 5-digit numeric code which is used to identify the manufacturer, distributor, or Government agency, etc., that supplies the item.

d. Part Number (Column (4)). Indicates the primary number used by the manufacturer (individual, company, firm, corporation, or Government activity), which controls the design and characteristics of the item by means of its engineering drawings, specifications standards, and inspection requirements to identify an item or range of items.

NOTE: When you use an NSN to requisition an item, the item you receive may have a different part number from the part ordered.

e. Description and Usable On Code (UOC) (Column (5)). This column includes the following information:

(1) The Federal item name and, when required, a minimum description to identify the item.

(2) The physical security classification of the item is indicated by the parenthetical entry which is a physical security classification abbreviation (e.g., Phy Sec Cl (C) - Confidential, Phy Sec Cl (S) - Secret, Phy Sec Cl (T) - Top Secret).

(3) Items that are included in kits and sets are listed below the name of the kit or set.

(4) Spare/repair parts that make up an assembled item are listed immediately following the assembled item line entry.

(5) Part numbers for bulk materials are referenced in this column in the line item entry for the item to be manufactured/fabricated.

(6) When the item is not used with all serial numbers of the same model, the effective serial numbers are shown on the last line(s) of the description (before UOC).

(7) The usable on code, when applicable. (See paragraph C-5, Special Information.)

(8) In the special tools list section, the basis of issue (BOI) appears as the last line (s) in the entry for each special tool, special TMDE, and other special support equipment. When density of equipment supported exceeds density spread indicated in the basis of issue, the total authorization is increased proportionately.

(9) The statement "END OF FIGURE" appears just before the last item description in Column 5 for a given figure in both section II and section III.

f. Qty (Column (6)). The QTY (quantity per figure column) indicates the quantity of the item used in the breakout shown on the illustration figure, which is prepared for a functional group, subfunctional group, or an assembly. A "V" appearing in this column in lieu of a quantity indicates that the quantity is variable and the quantity may vary from application to application.

#### C-4. EXPLANATION OF COLUMNS (SECTION IV).

##### a. National Stock Number (NSN) Index.

(1) Stock Number Column. This column lists the NSN by National item identification number (NIIN) sequence. The NIIN consists of the last nine

digits of the NSN (i.e.,  $\frac{\text{NSN}}{\text{NIIN}}$  5305-01-674-1467). When using this column to

locate an item, ignore the first 4 digits of the NSN. However, the complete NSN should be used when ordering items by stock number.

(2) Fig. column. This column lists the number of the figure where the item is identified/located. The figures are in numerical order in section II and section III.

(3) Item Column. The item number identifies the item associated with the figure listed in the adjacent FIG. column. This item is also identified by the NSN listed on the same line.

b. Part Number Index. Part numbers in this index are listed by part number in ascending alphanumeric sequence (i. e., vertical arrangement of letter and number combination which places the first letter or digit of each group in order A through Z, followed by the numbers 0 through 9 and each following letter or digit in like order) .

(1) FSCM Column. The Federal Supply Code for Manufacturer (FSCM) is a 5-digit numeric code used to identify the manufacturer, distributor, or Government agency, etc., that supplies the item

(2) Part Number Column. Indicates the primary number used by the manufacturer (individual, firm, corporation, or Government activity), which controls the design and characteristics of the item by means of its engineering drawings, specification standards, and inspection requirements to identify an item or range of items.

(3) Stock Number Column. This column lists the NSN for the associated part number and manufacturer identified in the PART NUMBER and FSCM columns to the left.

(4) Fig. Column. This column lists the number of the figure where the item is identified/located in sections II and III.

(5) Item Column. The item number is that number assigned to the item as it appears in the figure referenced in the adjacent figure number column.

**C-5. SPECIAL INFORMATION**

Use the following subparagraphs as applicable:

a. Usable On Code. The usable on code appears in the lower left corner of the description column heading. Usable on codes are shown as "UOC:....." in the description column (justified left) on the first line applicable item description/nomenclature. Uncoded items are applicable to all models. Identification of the usable on codes used in the RPSTL are:

<u>Code</u>	<u>used on</u>	
PAA	Model M114	(These codes and model numbers are examples only.)
PAB	Model M114A	
PAC	Model M114B	

b. Fabrication Instructions. Bulk materials required to manufacture items are listed in the bulk material functional group of this RPSTL. Part numbers for bulk materials are also referenced in the description column of the line item entry for the item to be manufactured/fabricated. Detailed fabrication instructions for items source codes to be manufactured or fabricated are found in appendix E of this manual.

d. Kits. Line item entries for repair parts kits appear in a group in section II. (See table of contents.)

Index Numbers. Items which have the word BULK in the figure column will have an index number shown in the item number column. This index number is a cross-reference between the National stock number/part number index and the bulk material list in section II.

f. Associated Publications. The publication listed helm pertains to the M231 submachine gun and its components:

<u>Publication</u>	<u>Short Title</u>
TM 9-1005-309-10	Submachine Gun, 5.56mm: Port, Firing, M231

**C-6. HOW TO LOCATE REPAIR PARTS**

a. When National Stock Number or Part Number is Not Known.

(1) First. Using the table of contents, determine the assembly group or subassembly group to which the item belongs. This is necessary since figures are prepared for assembly groups and subassembly groups, and listings are divided into the same groups.

(2) Second. Find the figure covering the assembly group or subassembly group to which the item belongs.

(3) Third. Identify the item on the figure and note the item number.

(4) Fourth. Refer to the repair parts list for the figure to find the part number for the item number noted on the figure.

(5) Fifth. Refer to the part number index to find the NSN, if assigned.

b. When National Stock Number or Part Number is Known.

(1) First. Using the index of National stock numbers and part numbers, find the pertinent National stock number or part number. The NSN index is in National item identification number (NIIN) sequence. (See para C-4a.(1)). The part numbers in the part number index are listed in ascending alphanumeric sequence. (See C-4.b). Both indexes cross-reference you to the illustration figure and item number of the item you are linking for.

(2) Second. After finding the figure and item number, verify that the item is the one you're looking for, then locate the item number in the repair parts list for the figure.

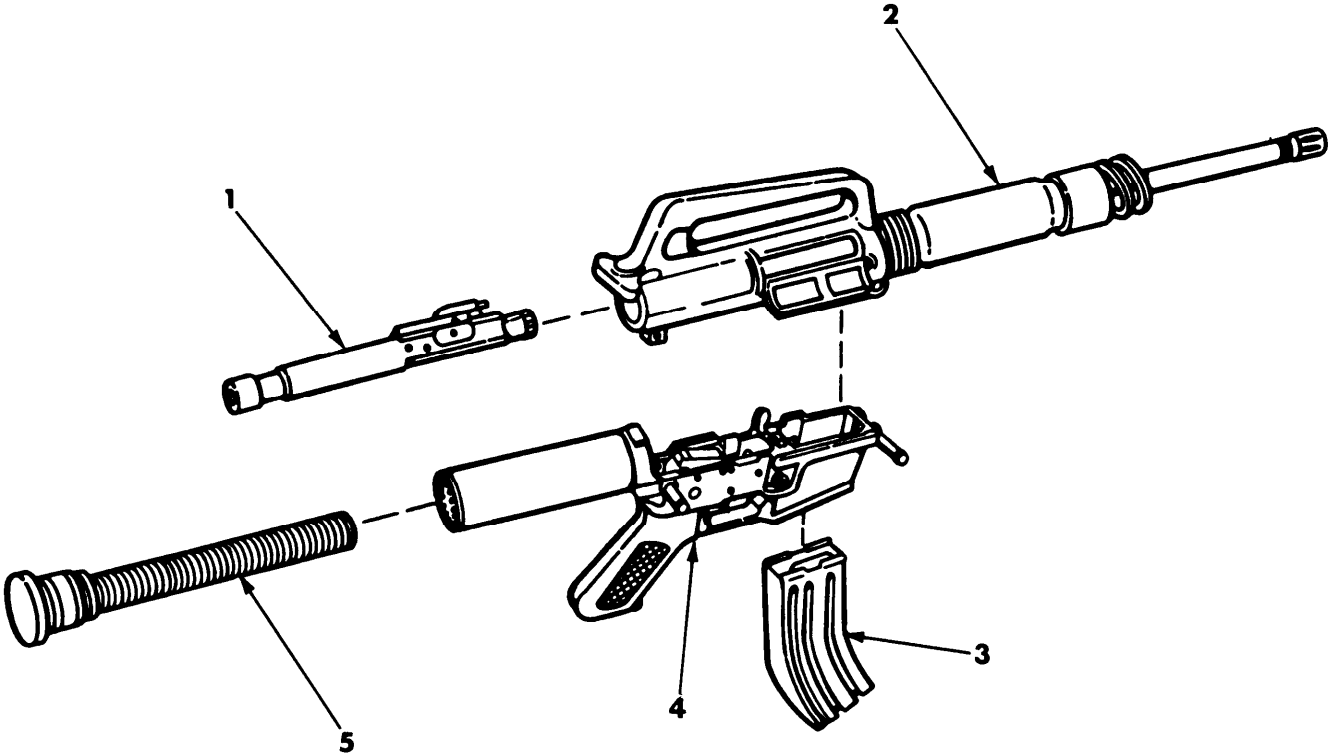

Figure C-1. Submachine Gun, 5.56-mm Port, Firing, M231 (9327045) (Group 00).

## SECTION II

TM9-1005-309-23&amp;P

CHANGE 1

(1) ITEM NO	(2) SMR CODE	(3) FSCM	(4) PART NUMBER	(5) DESCRIPTION AND USABLE ON CODE (UOC)	(6) QTY
				GROUP 00 FIG. C-1 SUBMACHINE GUN, 5.56 MM PORT, FIRING,M231 9327045	
1	AFFFF	19200	9327072	BOLT CARRIER AND STRIKER ASSEMBLY	1
2	AFFFF	19200	9327227	UPPER RECEIVER AND BARREL ASSEMBLY	1
3	PACZZ	19200	8448670	MAGAZINE,CARTRIDGE	1
4	XAFFA	19200	9327230	LOWER RECEIVER AND RECEIVER EXTENSION ASSEMBLY	1
5	AFFFF	19200	11828593	DRIVE SPRING AND GUIDE ASSEMBLY	1
				END OF FIGURE	

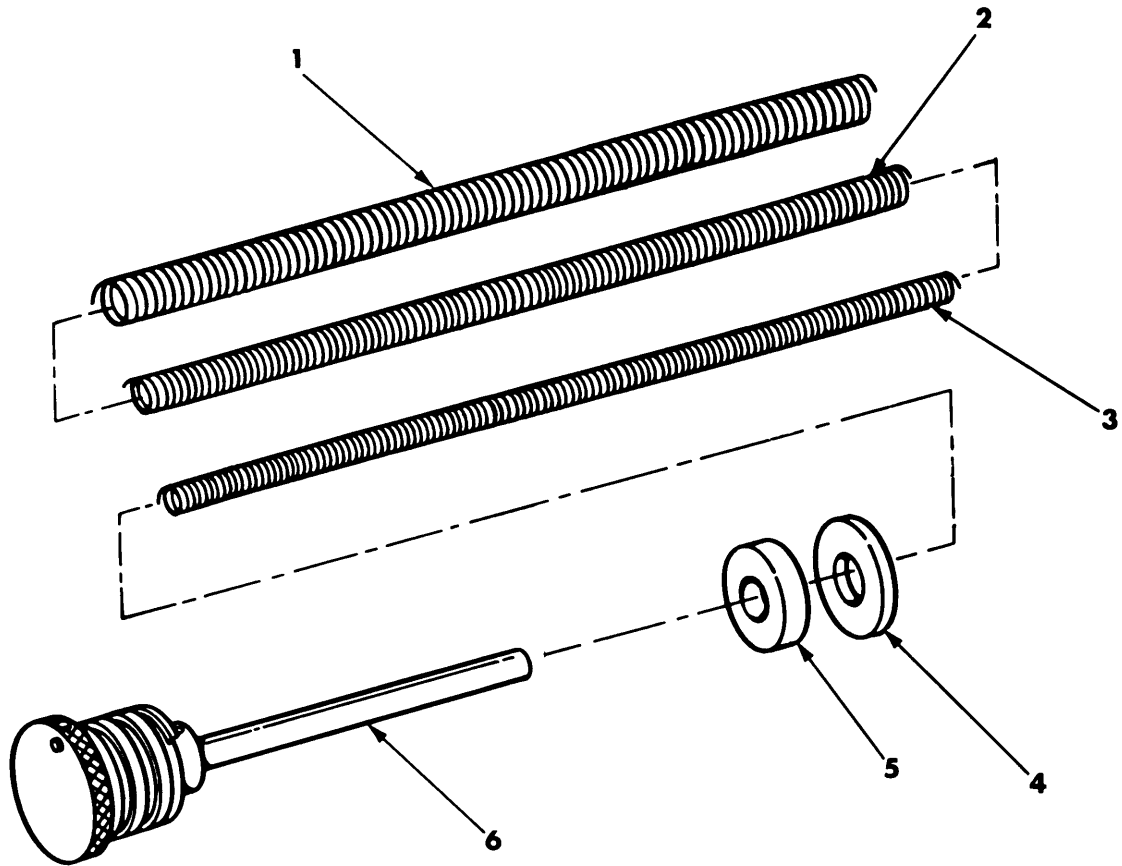

Figure C-2. Drive Spring and Guide Assembly (11828593) (Group 01).

SECTION II

TM9-1005-309-23&P

CHANGE 1

(1) ITEM NO	(2) SMR CODE	(3) FSCM	(4) PART NUMBER	(5) DESCRIPTION AND USABLE ON CODE (UOC)	(6) QTY
				GROUP 01 FIG.C-2 DRIVE SPRING AND GUIDE ASSEMBLY 11828593	
1	PAOZZ	19200	9326121	SPRING,HELICAL, COMPRESSION (OUTER)	1
2	PAOZZ	19200	9326122	SPRING,HELICAL, COMPRESSION (MIDDLE)	1
3	PAOZZ	19200	9326123	SPRING,HELICAL, COMPRESSION (INNER)	1
4	PAOZZ	19200	9327060	WASHER,FLAT	1
5	PAOZZ	19200	9327058	BUFFER,RECOIL MECHANISM	1
6	PAFFF	19200	9327063	RETAINER ASSEMBLY	1
				END OF FIGURE	

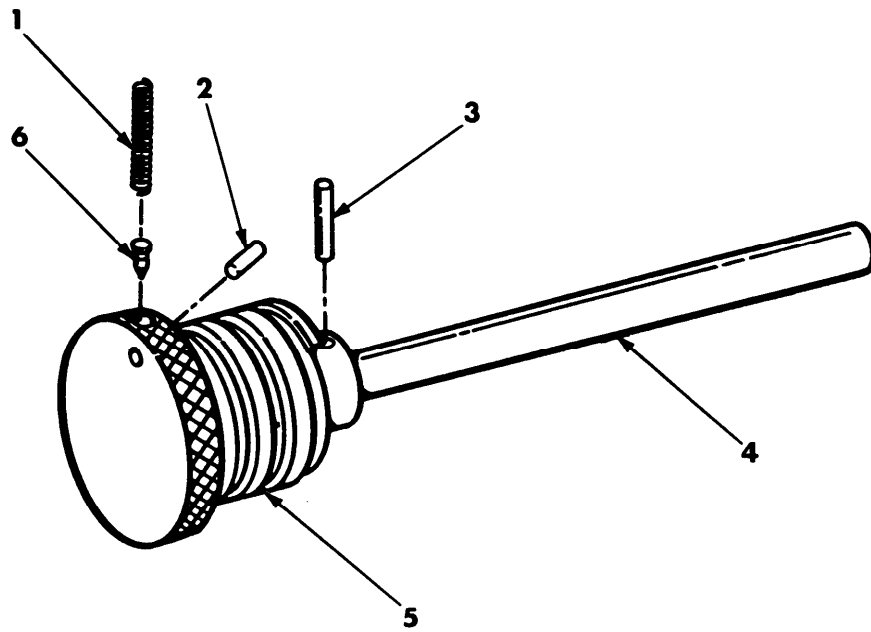

Figure C-3. Retainer Assembly (9327063) (Group 0101).

## SECTION II

TM9-1005-309-23&amp;P

CHANGE 1

(1) ITEM NO	(2) SMR CODE	(3) FSCM	(4) PART NUMBER	(5) DESCRIPTION AND USABLE ON CODE (UOC)	(6) QTY
GROUP 0101					
FIG.C-3 RETAINER ASSEMBLY 9327063					
1	PAOZZ	19204	8448516	SPRING,HELICAL, COMPRESSION	1
2	PAOZZ	96906	MS16562-105	PIN,SPRING	1
3	PAFZZ	96906	MS16562-118	PIN,SPRING	1
4	XAFZZ	19200	9327065	ROD,RETAINER	1
5	XAFZZ	19200	9327064	RETAINER, SPRING	1
6	PAOZZ	19204	8448631	DETENT,SAFETY	1
END OF FIGURE					

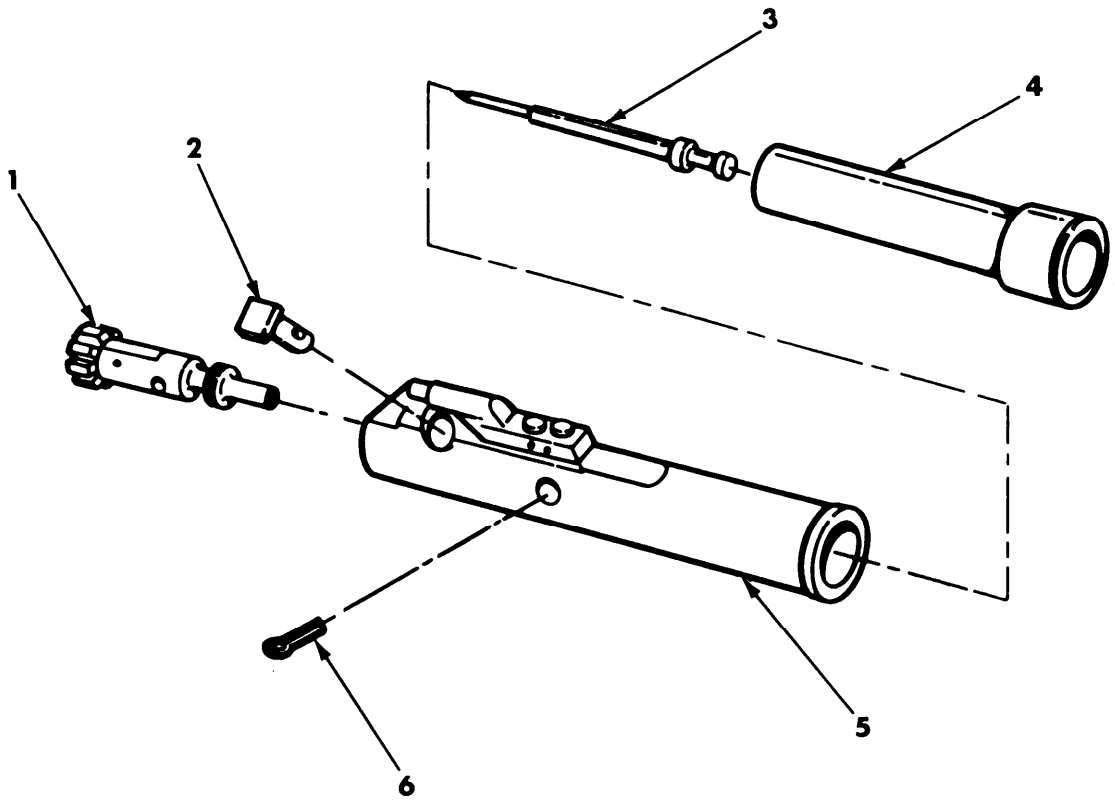

Figure C-4. Bolt Carrier and Striker Assembly (9327072) (Group 02).

## SECTION II

TM9-1005-309-23&amp;P

CHANGE 1

(1) ITEM NO	(2) SMR CODE	(3) FSCM	(4) PART NUMBER	(5) DESCRIPTION AND USABLE ON CODE (UOC)	(6) QTY
GROUP 02					
FIG.C-4 BOLT CARRIER AND STRIKER					
ASSEMBLY 9327072					
1	PAFFF	19200	9327073	BOLT,BREECH	1
2	PAOZZ	19204	8448502	PIN,BOLT CAM	1
3	PAFZZ	19204	8448503	PIN,FIRING	1
4	PAFZZ	19200	9327043	HAMMER,FIRING, SMALL	1
5	PAFZZ	19200	9327071	BOLT CARRIER AND KEY ASSEMBLY	1
6	PAOZZ	19204	8448504	PIN,FIRING PIN RETAINER	1
END OF FIGURE					

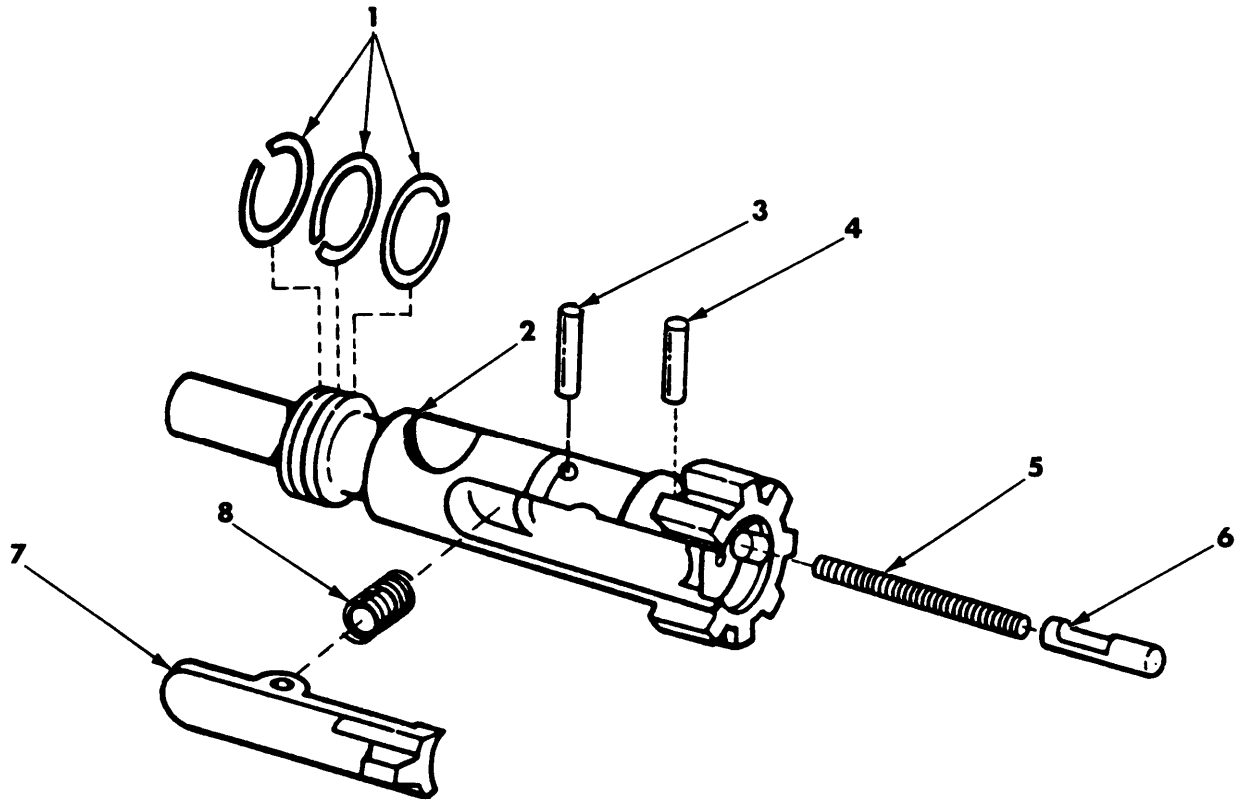

Figure C-5. Breech Bolt (9327073) (Group 0201).

## SECTION II

TM9-1005-309-23&amp;P

CHANGE 1

(1) ITEM NO	(2) SMR CODE	(3) FSCM	(4) PART NUMBER	(5) DESCRIPTION AND USABLE ON CODE (UOC)	(6) QTY
GROUP 0201					
FIG.C-5 BREECH BOLD 9327073					
1	PAFZZ	19204	8448511	RING,BOLT	3
2	XAFZZ	19204	8448510	BOLT	1
3	PAOZZ	19204	8448513	PIN,EXTRACTOR	1
4	PAOZZ	96906	MS16562-98	PIN,SPRING	1
5	PAOZZ	19204	8448516	SPRING,HELICAL, COMPRESSION	1
6	PAOZZ	19204	8448515	EJECTOR,CARTRIDGE	1
7	PAOZZ	19204	8448512	EXTRACTOR,CARTRIDGE	1
8	PAOZZ	19200	11828591	SPRING ASSEMBLY, EXTRACTOR	1

END OF FIGURE

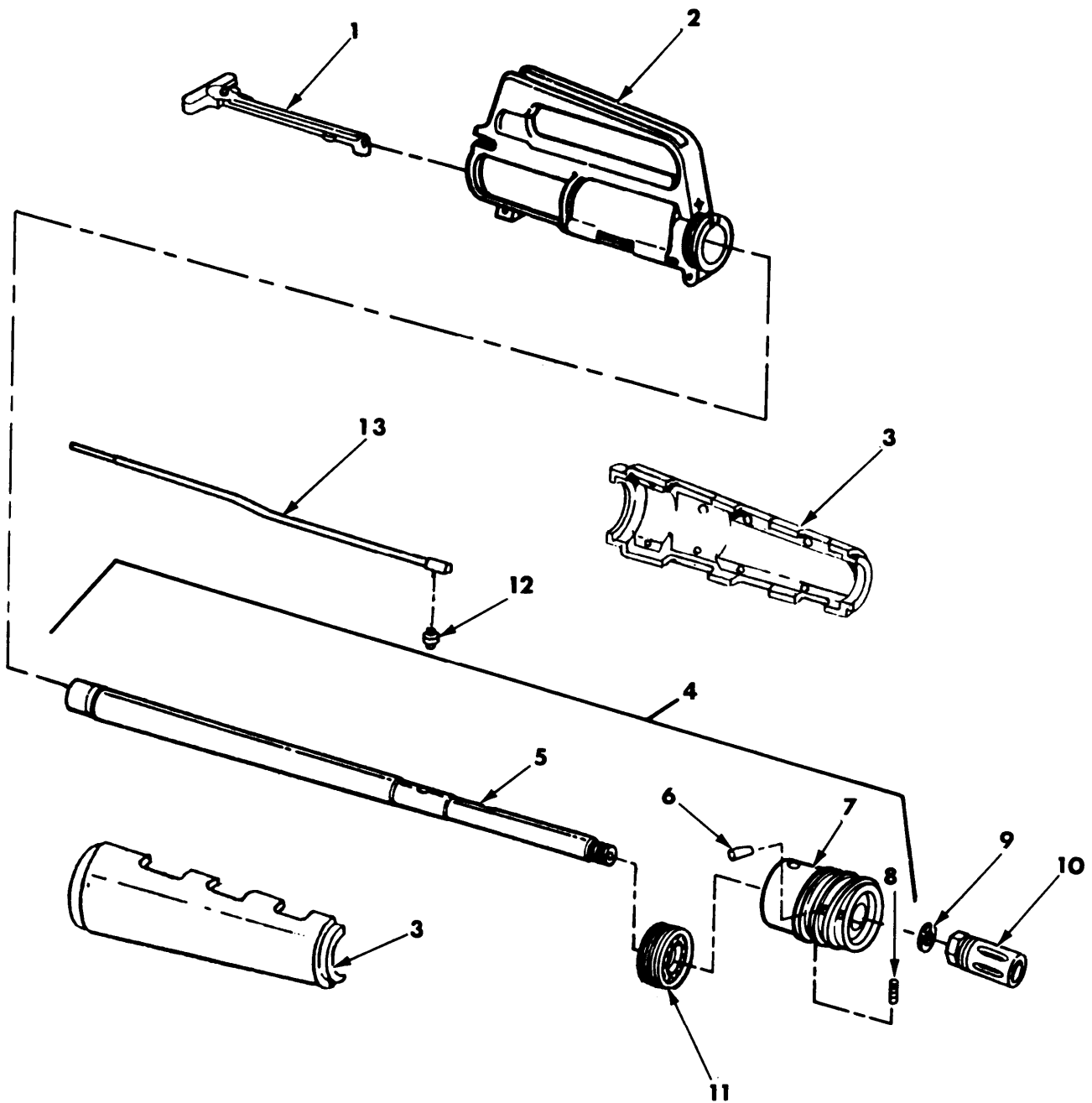

Figure C-6. Upper Receiver and Barrel Assembly (9327227) and Barrel and Barrel Collar Assembly (11828592) (Group 03/0304).

## SECTION II

TM9-1005-309-23&amp;P

CHANGE 1

(1) ITEM NO	(2) SMR CODE	(3) FSCM	(4) PART NUMBER	(5) DESCRIPTION AND USABLE ON CODE (UOC)	(6) QTY
				GROUP 03,0304	
				FIG.C-6 UPPER RECEIVER AND BARREL ASSEMBLY 9327227 & BARREL AND BARREL COLLAR ASSEMBLY 11828592	
1	PAOOO	19204	8448517	HANDLE ASSEMBLY, CHARGING	1
2	AFFFF	19200	9327228	UPPER RECEIVER ASSEMBLY	1
3	PAOZZ	19200	9327076	HANDGUARD	2
4	PAFFF	19200	11828592	BARREL AND BARREL COLLAR ASSEMBLY	1
5	XAFZZ	19200	9327056	..BARREL AND BARREL EXTENSION ASSEMBLY	1
6	PAFZZ	96906	MS24692-210	..PIN, TAPERED, PLAIN	2
7	XAFZZ	19200	9327061	..COLLAR, BARREL	1
8	PAFZZ	96906	MS51976-62	..SETSCREW	1
9	PAFZZ	19204	8448577	WASHER, LOCK, FLASH SUPPRESSOR	1
10	PAFZZ	19204	8448576	SUPPRESSOR, FLASH	1
11	AFFFF	19204	8448552	BARREL NUT ASSEMBLY	1
12	PAFZZ	19200	9327090	SEAL, GAS	1
13	PAFZZ	19200	9327068	TUBE, BENT, METALLIC	1

END OF FIGURE

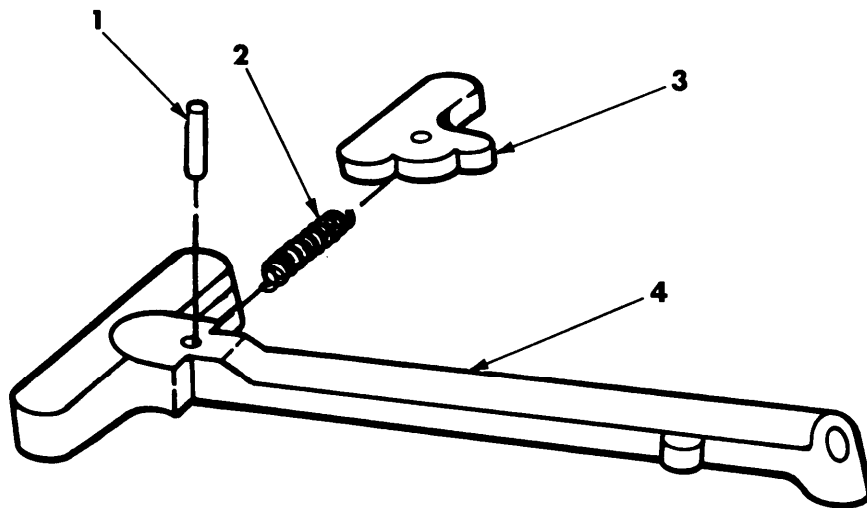

Figure C-7. Charging Handle Assembly (8448517) (Group 0301).

## SECTION II

TM9-1005-309-23&amp;P

CHANGE 1

(1) ITEM NO	(2) SMR CODE	(3) FSCM	(4) PART NUMBER	(5) DESCRIPTION AND USABLE ON CODE (UOC)	(6) QTY
				GROUP 0301 FIG.C-7 CHARGING HANDLE ASSEMBLY 8448517	
1	PAOZZ	19200	8448521	PIN, SPRING	1
2	PAOZZ	19204	8448520	SPRING, HELICAL, COMPRESSION	1
3	PAOZZ	19200	8448519	LATCH, CHARGING HANDLE	1
4	XAOZZ	19204	8448518	HANDLE, CHARGING	1

END OF FIGURE

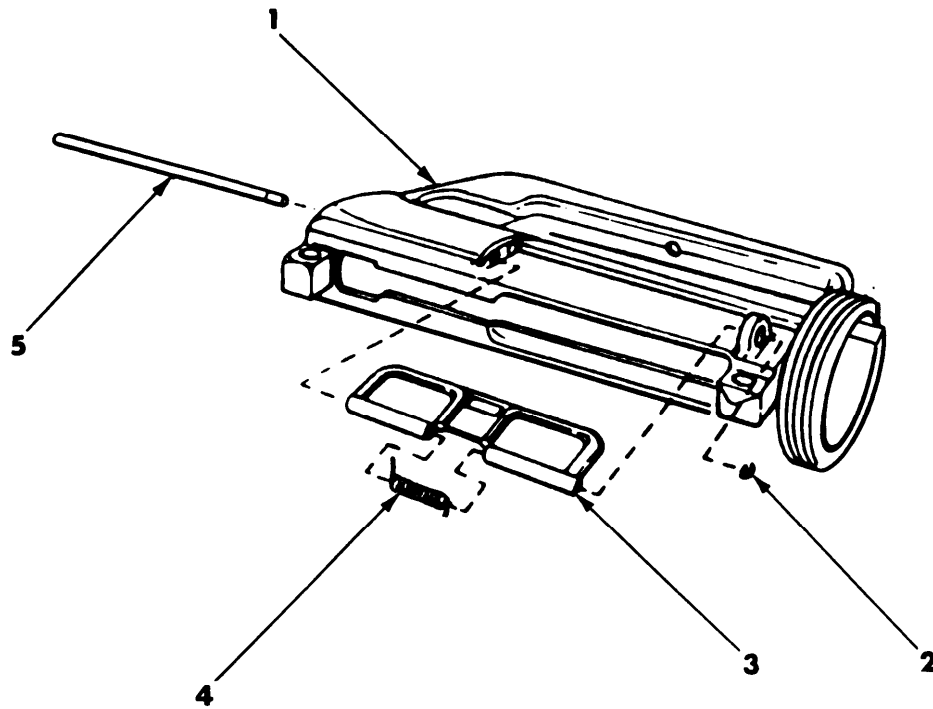

Figure C-8. Upper Receiver Assembly (9327228) (Group 0302).

## SECTION II

TM9-1005-309-23&amp;P

CHANGE 1

(1) ITEM NO	(2) SMR CODE	(3) FSCM	(4) PART NUMBER	(5) DESCRIPTION AND USABLE ON CODE (UOC)	(6) QTY
				GROUP 0302	
				FIG.C-8 UPPER RECEIVER ASSEMBLY	
				9327228	
1	PAFZZ	19200	9325003	RECEIVER, UPPER	1
2	PAOZZ	96906	MS16632-1012	RING, RETAINING	1
3	PAOZZ	19204	8448525	COVER, EJECTION PORT	1
4	PAOZZ	19204	8448532	SPRING, HELICAL, TORSION	1
5	PAOZZ	19204	8448533	PIN, EJECTION PORT	1
				END OF FIGURE	

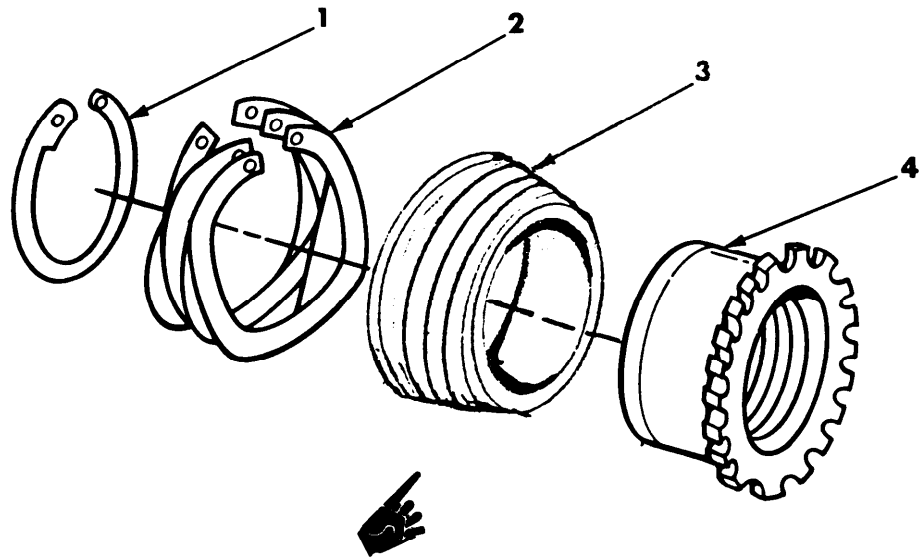

Figure C-9. Barrel Nut Assembly (8448552) (Group 0303).

Change 3

## SECTION II

TM9-1005-309-23&amp;P

CHANGE 3

(1) ITEM NO	(2) SMR CODE	(3) FSCM	(4) PART NUMBER	(5) DESCRIPTION AND USABLE ON CODE (UOC)	(6) QTY
GROUP 0303					
FIG.C-9 BARREL NUT ASSEMBLY 8448552					
1	PAFZZ	96906	MS16626-1137	RING,RETAINING	1
2	PAFZZ	19204	8448555	SPRING,SLIP RING,	1
3	PAFZZ	19204	8448712	RING,SLIP, HAND GUARD	1
4	PAFZZ	19204	8448553	NUT,BARREL	1

END OF FIGURE

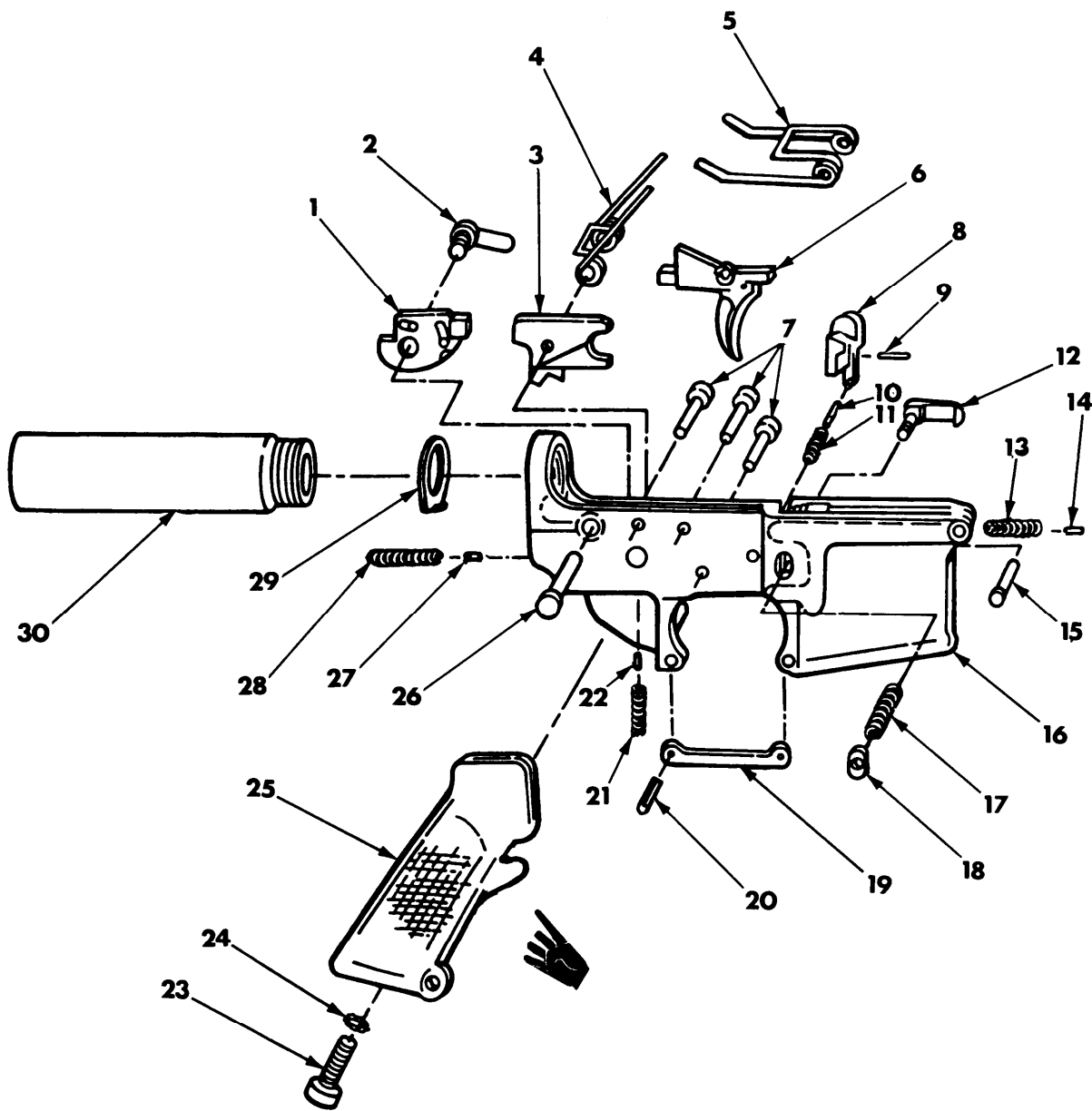

Figure C-10. Lower Receiver and Receiver Extension Assembly (9327230) (Group 04).

(1) ITEM NO	(2) SMR CODE	(3) FSCM	(4) PART NUMBER	(5) DESCRIPTION AND USABLE ON CODE (UOC)	(6) QTY
GROUP 04					
FIG.C-10 LOWER RECEIVER AND RECEIVER					
EXTENSION ASSEMBLY 9327230					
1	PAFZZ	19200	9327074	RETAINER,PIN	1
2	PAFZZ	19200	9357808	SELECTOR,FIRE CONTROL	1
3	PAFZZ	19200	9327051	SEAR	1
4	PAFZZ	19200	9327052	SPRING,HELICAL, TORSION	1
5	PAFZZ	19204	8448593	SPRING,HELICAL, TORSION	1
6	PAFZZ	19200	9344968	TRIGGER	1
7	PAFZZ	19200	9327044	PIN, STRAIGHT, HEADED	3
8	PAFZZ	19200	9327059	CATCH,BOLT	1
9	PAFZZ	96906	MS16562-119	PIN,SPRING	1
10	PAFZZ	19204	8448634	PLUNGER,BOLT CATCH	1
11	PAFZZ	19204	8448633	SPRING,HELICAL, COMPRESSION	1
12	PAFZZ	19204	8448638	CATCH,MAGAZINE	1
13	PAOZZ	19204	8448586	SPRING,HELICAL, COMPRESSION	1
14	PAOZZ	19204	8448585	DETENT,TAKEDOWN PIN	1
15	PAOZZ	19204	8448621	PIN,PIVOT	1
16	XAFFA	19200	9327037	RECEIVER LOWER	1
17	PAFZZ	19204	8448637	SPRING,HELICAL, COMPRESSION	1
18	PAFZZ	19204	8448636	BUTTON,MAGAZINE CATCH	1
19	PAFZZ	19204	8448587	GUARD,TRIGGER	1
20	PAFZZ	96906	MS16562-35	PIN,SPRING	1
21	PAOZZ	19204	8448516	SPRING,HELICAL, COMPRESSION	1
22	PAOZZ	19204	8448631	DETENT,SAFETY	1
23	PAOZZ	88044	AN501D416-18	SCREW,MACHINE	1
24	PAOZZ	96906	MS35335-61	WASHER,LOCK	1
25	PAOZZ	19200	9349127	GRIP,RIFLE	1
26	PAFZZ	19204	8448584	PIN,TAKEDOWN	1
27	PAFZZ	19204	8448585	DETENT,TAKEDOWN PIN	1
28	PAFZZ	19204	8448586	SPRING,HELICAL, COMPRESSION	1
29	PAFZZ	19200	9349301	PLATE,SPRING RETAINER	1
30	PAFZZ	19200	9327062	EXTENSION,RECEIVER	1

END OF FIGURE



SECTION II

TM9-1005-309-23&P

CHANGE 1

(1) ITEM NO	(2) SMR CODE	(3) FSCM	(4) PART NUMBER	(5) DESCRIPTION AND USABLE ON CODE (UOC)	(6) QTY
				GROUP 9999 FIG.BULK	
1	PAOZZ	81348	GGGK00275	KEY, SOCKET HEAD SCREW	1
2	PAFZZ	81348	QQT580	METAL BAR, STEEL, ROUND, 6FT MIN & 14FT.MAX, 0.375 OD	1

END OF FIGURE

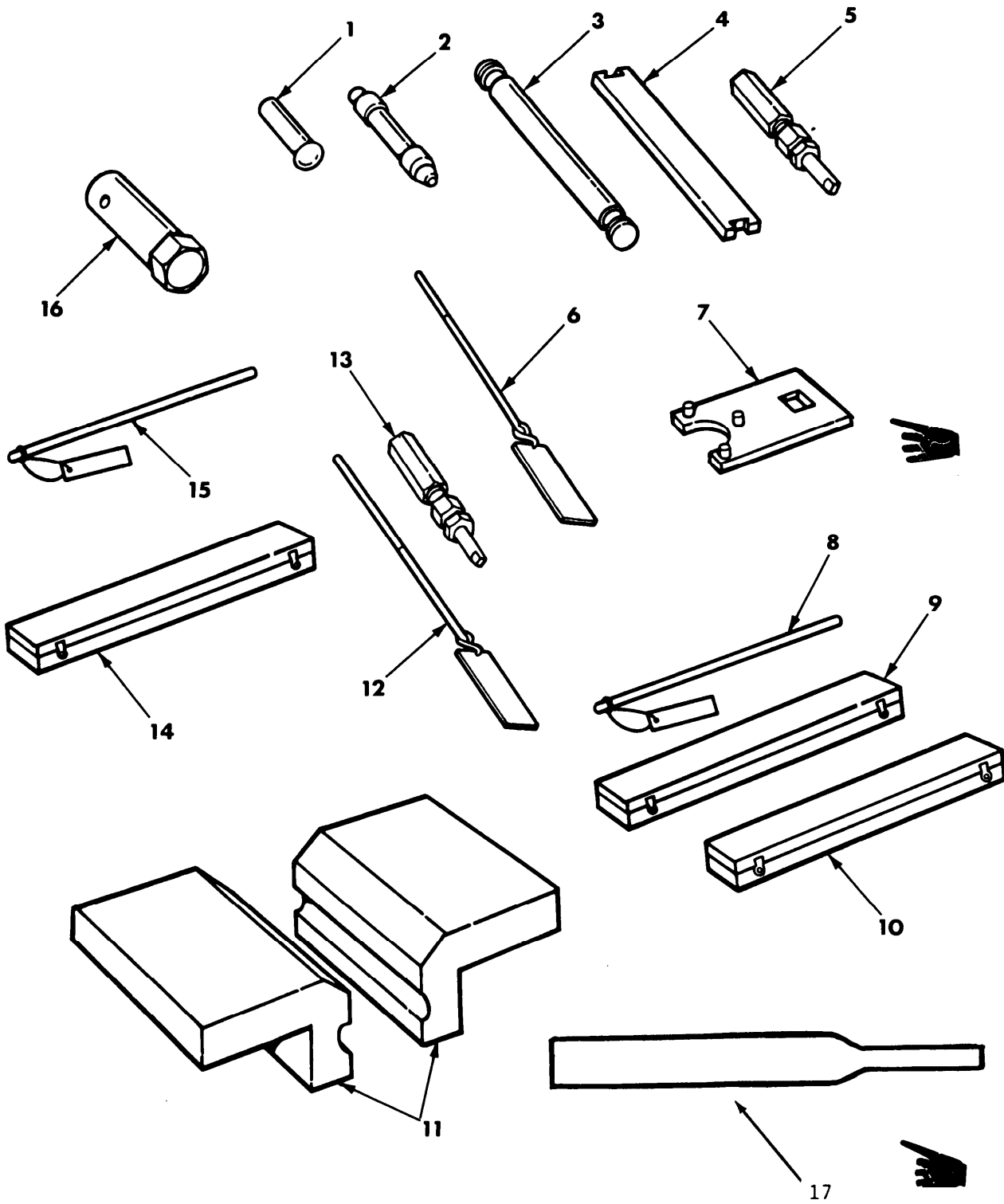

Figure C-11. Special Tools (Group 9500).

(1) ITEM NO	(2) SMR CODE	(3) FSCM	(4) PART NUMBER	(5) DESCRIPTION AND USABLE ON CODE (UOC)	(6) QTY
				GROUP 9500 FIG.C-11 SPECIAL TOOLS	
	ADFFA	19204	8426685	TOOL AND GAGE SET DS/GS SUPPORT MAINTENANCE FOR 5.56MM RIFLE, M16 SERIES AND M231 FIRING PORT WEAPON BOI:2 AUTH BY SVC BTRY/CO	
1	PAFZZ	19204	8448201	..REFLECTOR TOOL, CHANBER,PART OF KIT P/N 8426685	
2	PAFZZ	19204	7799734	..GAGE,HEADSPACE PART OF KIT P/N 8426685	
3	PAFZZ	19204	8448202	..GAGE,STRAIGHTNESS PART OF KIT P/ N 8426685	
4	PAFZZ	19204	7799735	..GAGE,FIRING PIN PART OF KIT P/N 8426685	
5	PAFZZ	19204	12006472	..GAGE,PLUG,TAPER PART OF KIT P/N 8426685	
6	PAFZZ	19204	8448677	..GAGE,MUZZLE EROSION PART OF KIT P/N 8426685 (M16 ONLY)	
7	PAFZZ	19204	11010033	..WRENCH,COMBINATION PART OF KIT P/ N 8426685	
8	PAFZZ	19205	7799792	..GAGE,BARREL EROSION PART OF KIT P/N 8426685 (M16 ONLY)	
9	PAFZZ	19204	12006359	..CASE,BORE GAGE PART OF KIT P/N 8426685	
10	PAFZZ	19205	7799809	..CASE,RIFLE BORE PART OF KIT P/N 8426685 (M16 ONLY)	
11	PAFZZ	19204	11010032	..FIXTURE,BARREL PART OF KIT P/N 8426685	
12	PAFZZ	19204	8448496	..GAGE,BARREL,EROSION PART OF KIT P/N 8426685	
13	PAFZZ	19200	12620101	..GAGE,PLUG,PLAIN PART OF KIT P/N 8426685	
14	PAFZZ	19200	12551888	CASE,BORE GAGE 2 PER DS/GS SHOP A/R (M231 ONLY)	
15	PAFZZ	19200	12551887	GAGE,BARREL,EROSION 2 PER DS/GS SHOP A/4 (M231 ONLY)	
16	PAFZZ	19200	11828589	WRENCH,EXTENSION 2 PER DS/GS SHOP A/4 (M231 ONLY)	
17	PAOZZ	19200	12926769	TOOL,BOLT CARRIER KEY: 2 PER ORG/DS END OF FIGURE	2



## NATIONAL STOCK NUMBER AND PART NUMBER INDEX

NATIONAL STOCK NUMBER INDEX		NATIONAL STOCK NUMBER INDEX	
STOCK NUMBER	FIG. ITEM	STOCK NUMBER	FIG. ITEM
5315-00-017-9537	C-10 15	5360-00-992-7292	C-3 1
1005-00-017-9546	C-6 1		C-5 5
5315-00-017-9547	C-4 3		C-10 21
5315-00-017-9552	C-7 1	1005-00-992-7294	C-4 2
5315-00-054-5610	C-6 6	1005-00-992-7299	C-10 19
1005-00-056-2201	C-10 12	5360-00-992-7301	C-10 17
5360-00-056-2246	C-10 11	1005-00-992-7302	C-10 18
1005-00-056-2247	C-10 10	5360-00-992-7308	C-10 5
1005-01-148-4805	C-10 25	5360-00-999-0404	C-7 2
5315-00-058-6063	C-3 3	1005-00-999-0405	C-7 3
5305-00-059-2494	C-6 8	1005-00-999-1509	C-4 6
5365-00-064-2652	C-8 2	5220-01-014-8183	C-11 12
4933-00-070-7814	C-11 2	4933-01-035-5607	C-11 9
4933-00-070-7815	C-11 4	5220-01-043-9473	C-11 5
4933-00-070-9151	C-11 11	5220-01-075-5004	C-11 13
4933-00-070-9152	C-11 7	1005-01-081-4166	C-6 3
5220-00-155-4925	C-11 6	1005-01-081-4278	C-2 6
5120-00-198-5398	BULK 1	1005-01-081-4279	C-4 5
4933-00-221-9391	C-11 3	1005-01-081-4579	C-4 1
5365-00-252-6853	C-9 1	4710-01-081-4664	C-6 13
5315-00-421-4827	C-3 2	5310-01-081-4700	C-2 4
5310-00-527-3634	C-10 24	1005-01-081-4829	C-6 12
5315-00-597-5086	C-5 4	1005-01-081-4832	C-8 1
9510-00-640-4407	BULK 2	1005-01-081-4833	C-10 30
4933-00-800-7508	C-11 1	1005-01-081-4835	C-11 16
5315-00-812-3312	C-10 9	5360-01-081-4904	C-2 2
5315-00-814-3530	C-10 20	5360-01-081-4905	C-2 3
4933-00-912-3409	C-11 8	5360-01-081-4906	C-10 4
5305-01-268-1191	C-10 23	1005-01-081-5568	C-10 8
1005-00-921-5004	C-1 3	1005-01-081-5624	C-2 5
1005-00-933-8089	C-6 10	1005-01-082-4840	C-10 3
4933-00-944-7084	C-11 10	1005-01-083-4881	C-10 1
1005-00-978-1022	C-8 3	5315-01-083-7893	C-10 7
1005-00-978-1023	C-8 5	1005-01-084-1413	C-6 4
5360-00-978-1025	C-8 4	1005-01-084-9844	C-5 8
1005-00-978-1034	C-9 4	5360-01-085-0720	C-2 1
1005-00-087-8998	C-9 3	1005-01-085-5163	C-4 4
5360-00-978-1036	C-9 2	1005-01-147-3263	C-10 29
1005-00-992-6653	C-10 26	1005-01-159-8090	C-10 2
1005-00-992-6654	C-10 14	1005-01-163-3727	C-10 6
	C-10 27	5210-01-229-1617	C-11 14
	C-10 13	5210-01-230-3349	C-11 15
5360-00-992-6655	C-10 28	1005-01-310-0370	C-11 17
	C-3 6		
	C-10 22		
1005-00-992-7280	C-6 9		
1005-00-992-7287	C-5 1		
1005-00-992-7288	C-5 7		
1005-00-992-7290	C-5 3		
1005-00-992-7291	C-5 6		

## NATIONAL STOCK NUMBER AND PART NUMBER INDEX

FSCM	PART NUMBER	PART NUMBER INDEX STOCK NUMBER	FIG.	ITEM
81348	GGGK00275	5120-00-198-5398	BULK	1
96906	MS16562-105	5315-00-421-4827	C-3	2
96906	MS16562-118	5315-00-158-6063	C-3	3
96906	MS16562-119	5315-00-812-3312	C-10	9
96906	MS16562-35	5315-00-814-3530	C-10	20
96906	MS16562-98	5315-00-597-5086	C-5	4
96906	MS16626-1137	5365-00-252-6853	C-9	1
96906	MS16632-1012	5365-00-064-2652	C-8	2
96906	MS24692-210	5315-00-054-5610	C-6	6
88044	AN501D416-18	5305-01-268-1191	C-10	23
96906	MS35335-61	5310-00-527-3634	C-10	24
96906	MS51976-62	5305-00-059-2494	C-6	8
81348	QQT580	9510-00-640-4407	BULK	2
19204	11010032	4933-00-070-9151	C-11	11
19204	11010033	4933-00-070-9152	C-11	7
19200	11828589	1005-01-081-4835	C-11	16
19200	11828591	1005-01-084-9844	C-5	8
19200	11828592	1005-01-084-1413	C-6	4
19200	11828593		C-1	5
19204	12006359	4933-01-035-5607	C-11	9
19204	12006472	5220-01-043-9473	C-11	5
19200	12551887	5210-01-230-3349	C-11	15
19200	12551888	5210-01-229-1617	C-11	14
19200	12620101	5220-01-075-5004	C-11	13
19204	7799734	4933-00-070-7814	C-11	2
19204	7799735	4933-00-070-7815	C-11	4
19205	7799792	4933-00-912-3409	C-11	8
19205	7799809	4933-00-944-7084	C-11	10
19204	8426685		C-11	
19204	8448201	4933-00-800-7508	C-11	1
19204	8448202	4933-00-221-9391	C-11	3
19204	8448496	5220-01-014-8183	C-11	12
19204	8448502	1005-00-992-7294	C-4	2
19204	8448503	5315-00-017-9547	C-4	3
19204	8448504	1005-00-999-1509	C-4	6
19204	8448510		C-5	2
19204	8448511	1005-00-992-7287	C-5	1
19204	8448512	1005-00-992-7288	C-5	7
19204	8448513	1005-00-992-7290	C-5	3
19204	8448515	1005-00-992-7291	C-5	6
19204	8448516	5360-00-992-7292	C-3	1
			C-5	5
			C-10	21
19204	8448517	1005-00-017-9546	C-6	1
19204	8448518		C-7	4
19200	8448519	1005-00-999-0405	C-7	3
19204	8448520	5360-00-999-0404	C-7	2
19200	8448521	5315-00-017-9552	C-7	1
19204	8448525	1005-00-978-1022	C-8	3
19204	8448532	5360-00-978-1025	C-8	4
19204	8448533	1005-00-978-1023	C-8	5

## NATIONAL STOCK NUMBER AND PART NUMBER INDEX

FSCM	PART NUMBER	PART NUMBER INDEX STOCK NUMBER	FIG.	ITEM
19204	8448552		C-6	11
19204	8448553	1005-00-978-1034	C-9	4
19204	8448712	1005-00-087-8998	C-9	3
19204	8448555	5360-00-978-1036	C-9	2
19204	8448576	1005-00-933-8089	C-6	10
19204	8448577	1005-00-992-7280	C-6	9
19204	8448584	1005-00-992-6653	C-10	26
19204	8448585	1005-00-992-6654	C-10	14
			C-10	27
19204	8448586	5360-00-992-6655	C-10	13
			C-10	28
19204	8448587	1005-00-992-7299	C-10	19
19204	8448593	5360-00-992-7308	C-10	5
19204	8448621	5315-00-017-9537	C-10	15
19204	8448631	1005-00-992-6667	C-3	6
			C-10	22
19200	9349127	1005-01-148-4805	C-10	25
19204	8448633	5360-00-056-2246	C-10	11
19204	8448634	1005-00-056-2247	C-10	10
19204	8448636	1005-00-992-7302	C-10	18
19204	8448637	5360-00-992-7301	C-10	17
19204	8448638	1005-00-056-2201	C-10	12
19200	8448670	1005-00-921-5004	C-1	3
19204	8448677	5220-00-155-4925	C-11	6
19200	9325003	1005-01-081-4832	C-8	1
19200	9326121	5360-01-085-0720	C-2	1
19200	9326122	5360-01-081-4904	C-2	2
19200	9326123	5360-01-081-4905	C-2	3
19200	9327037		C-10	16
19200	9327043	1005-01-085-5163	C-4	4
19200	9327044	5315-01-083-7893	C-10	7
19200	9327051	1005-01-082-4840	C-10	3
19200	9327052	5360-01-081-4906	C-10	4
19200	9327056		C-6	5
19200	9327058	1005-01-081-5624	C-2	5
19200	9327059	1005-01-081-5568	C-10	8
19200	9327060	5310-01-081-4700	C-2	4
19200	9327061		C-6	7
19200	9327062	1005-01-081-4833	C-10	30
19200	9327063	1005-01-081-4278	C-2	6
19200	9327064		C-3	5
19200	9327065		C-3	4
19200	9327068	4710-01-081-4664	C-6	13
19200	9327071	1005-01-081-4279	C-4	5
19200	9327072		C-1	1
19200	9327073	1005-01-081-4579	C-4	1
19200	9327074	1005-01-083-4881	C-10	1
19200	9327076	1005-01-081-4166	C-6	3
19200	9327090	1005-01-081-4829	C-6	12

## NATIONAL STOCK NUMBER AND PART NUMBER INDEX

FSCM	PART NUMBER	PART NUMBER INDEX STOCK NUMBER	FIG.	ITEM
19200	9327227		C-1	2
19200	9327228		C-6	2
19200	9327230		C-1	4
19200	9344968	1005-01-163-3727	C-10	6
19200	9349301	1005-01-147-3263	C-10	29
19200	9357808	1005-01-159-8090	C-10	2
19200	12926769	1005-01-310-0370	C-11	17

# APPENDIX D

## EXPENDABLE/DURABLE SUPPLIES AND MATERIALS LIST

---

### Section I. INTRODUCTION

#### D-1. SCOPE

This appendix lists expendable supplies and materials you will need to operate and maintain the M231 submachine gun. This listing is for informational purposes only and is not authority to requisition the listed items. These items are authorized to you by CTA 50-970, Expendable/Durable Items (Except Medical, Class V, Repair Parts, and Heraldic Items) or CTA 8-100, Army Medical Department Expendable/Durable Items.

#### D-2. EXPLANATION OF COLUMNS

a. Column 1--Item Number. This number is assigned to the entry in the listing and is referenced in the narrative instructions to identify the material (e.g., "Use cleaning compound, item 5, app D.").

b. Column 2--Level. This column identifies the lowest level of maintenance that requires the listed item.

C ..... Operator/Crew  
O ..... Organizational Maintenance  
F ..... Direct Support Maintenance

c. Column 3--National Stock Number. This is the National stock number assigned to the item; use it to request or requisition the item.

d. Column 4--Description. Indicates the Federal item name and, if required, a description to identify the item. The last line for each item indicates the part number followed by the Federal Supply Code for Manufacturer (FSCM) in parentheses, if applicable.

e. Column 5--Unit of Measure (U/M). Indicates the measure used in performing the actual maintenance function. This measure is expressed by a two-character alphabetical abbreviation (e.g., ea, in., pr). If the unit of measure differs from the unit of issue, requisition the lowest unit of issue that will satisfy your requirements.

(1) ITEM NUMBER	(2) SECTION II. EXPENDABLE SUPPLIES AND MATERIALS LEVEL	(3) NATIONAL STOCK NUMBER	(4) LIST DESCRIPTION	(5) U/M
0.1	F	8135-01-201-3226	TUBING, NON-METALLIC: 36 IN. X 200 YD MIL-B-117 (81349)	YD
1	F	8135-00-222-4027	BARRIER MATERIAL, GREASEPROFED- WATERPROOFED, FLEXIABLE: 300-FT (91.44-M) ROLL MIL-B-121 (81349)	FT
2	F		BOX, SHIPPING: CLASS 1, STYLE 2 PPP-B-621 (81348)	EA
3	F		BOX, SHIPPING: CLEATED-PLYWOOD PPP-B-601 (81348)	EA
4	F	8115-00-190-4858	BOX, SHIPPING: FIBERBOARD, WEATHER RESISTANT PPP-B-636 (81348)	EA
5	O	8020-00-244-0153	BRUSH, ARTIST'S: H-B-241 (81348)	EA
6	O	7920-00-205-2401	BRUSH, CLEANING, TOOL AND PARTS: MILS43871 (81349)	EA
7	C	9920-00-292-9946	CLEANER, TOBACCO PIPE: COTTON TUFT, WIRE CORE (32 PER PG) 840507 (19203)	EA

8			CLEANING COMPOUND, RIFLE BORE: SMALL ARMS BORE CLEANING SOLUTION (RBC)	
	C	6850-00-224-6656	2-OZ (59.15-ML) BT	OZ
	O	6850-00-224-6657	8-OZ (236.59) CN	OZ
	O	6850-00-224-6663	1-GAL. (3.79-1) CN MIL-C-372 (81349)	GL
9	O	5350-00-221-0872	CLOTH, ABRASIVE: CROCUS CLOTH, JEAN CLOTH BACKING 50-SH PG A-A-1206 (58536)	HS
10	O	6850-00-281-1985	DRY CLEANING SOLVENT: (SD) 1-GAL. CN P-S-661 (02978)	GL
10.1	O		GLOVES, CHEMICAL AND OIL PROTECTIVE: SIZE 9 SIZE 10 SIZE 11 ZZ-G-381 (81348)	PR PR PR
		8415-00-823-7455		
		8415-00-823-7456		
		8415-00-823-7457		
11	F	9150-00-754-2595	GREASE, MOLYBDENUM DISULFIDE: LIQUID 1.75-LB (0.79-KG) CN MIL-G-21164 (81349)	LB
12	F	6850-00-826-0981	INSPECTION PENETRANT KIT: MIL-I-25135 (8139)	KT
13	O	9150-01-260-2534	LUBRICANT, SOLID FILM: 16-OZ (0.47-1) CN MIL-23398 (81349)	OZ
14	F	9150-00-281-2060	LUBRICATING OIL, GENERAL PURPOSE: 55-GAL. (208.20-1) DR VVL800 (81348)	GL
15	O	9150-00-292-9689	LUBRICATING OIL, WEAPONS: (LAW) 1-QT (0.95-1) CN MIL-L-14107 (81349)	QT

(1)	(2)	(3)	(4)	(5)
ITEM NUMBER	LEVEL	NATIONAL STOCK NUMBER	DESCRIPTION	U/M
16			LUBRICATING OIL, WEAPONS: (LSA), SEMIFLUID	
	C	9150-00-935-6597	2-OZ (59.15-ML) PLASTIC BT	OZ
	C	9150-00-889-3522	4-OZ (118.30-ML) BT	OZ
	O	9150-00-687-4241	1-QT (0.95-1) CN	QT
	O	9150-00-753-4686	1-GAL. (3.79-1) CN	GL
			MIL-L-46000 (81349)\	
16.1	F	8135-00-145-0137	PACKAGING CUSHIONING MATERIAL: 15 IN. X 15 IN. X 2 IN. SHEET	IN
			PPP-C-1752 (81348)	
16.2	F	8135-00-281-3920	PAPERBOARD, WRAPPING AND CUSHIONING: 250-FT (76.20-M) ROLL	FT
			A-A-1797 (58536)	
17	F	8135-00-664-4012	PAPER, VOLATILE CORROSION INHIBITOR TREATED: MEDIUM DUTY	FT
			600-FT (182.88-M) ROLL	
			MILP3420 (81349)	
18	C	7920-00-205-1711	RAG, WIPING: COTTON	LB
			50-LB (22.68-KG) BE.	
			AA531 (58536)	
19	F	8135-00-286-8565	STRAPPING: FLAT	IN
			5/8-IN. (1.59-CM) W COIL	
			QQ-S-781 (81348)	

20	C	1005-00-912-4248	SWAB, SMALL ARMS CLEANING: COTTON 1 PG (1000 PER PG) 11686408 (19204)	EA
21	F	7510-00-266-6712	TAPE, PRESSURE SENSITIVE ADHESIVE: PAPER BASIC 8783476 (19203)	YD
22	F	7510-00-297-6655	TAPE, PRESSURE SENSITIVE ADHESIVE: PAPER BASIC A-A-1683 (58536)	YD
23	F		TAPE, PRESSURE SENSITIVE ADHESIVE: 2160 IN. X 3/4 IN. ROLL PPP-T-97 (81348)	IN
24	C	1005-00-242-5687	BOTTLE, ASSEMBLY CYLINDRICAL 8448444 (19204)	EA



# APPENDIX E

## ILLUSTRATED LIST OF MANUFACTURED ITEMS

---

### E-1. INTRODUCTION

a. This appendix includes complete instructions for making items authorized to be manufactured or fabricated at organizational or direct support maintenance levels.

b. All bulk materials needed for manufacture of an item are listed by part number or specification number in a tabular list with the illustration.

All data on page E-2 deleted.



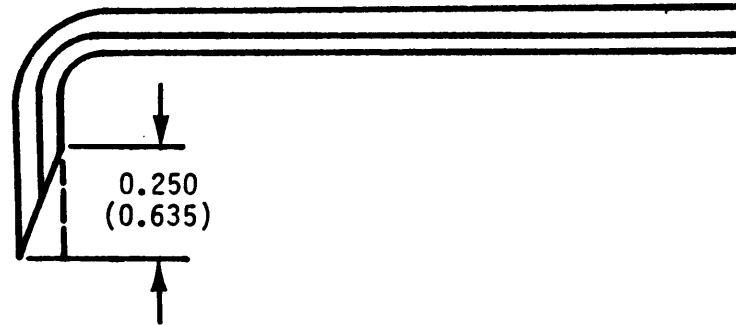

Dimension shown is in inches with the metric conversion to centimeters in parenthesis.

Figure 2. Pivot pin removing tool.

NOTES:

1. Fabricate from socket head screw key, NSN 5120-00-198-5398.
2. Tolerance is  $\pm 0.005$  in. ( $\pm 0.013$  cm).

■ All data on page E-4 deleted.

# ALPHABETICAL INDEX

Subject	Page 0* DS**
A	
Applying marking . . . . .	3-60
B	
Barrel and barrel collar assembly:	
Inspection . . . . .	3-44
Maintenance . . . . .	3-43
Reassembly/installation . . . . .	3-45
Repair/replacement . . . . .	3-44
Test . . . . .	3-45
Troubleshooting . . . . .	3-3, 3-6
Barrel nut assembly:	
Cleaning . . . . .	3-42
Disassembly . . . . .	3-42
Inspection . . . . .	3-42
Maintenance . . . . .	3-41
Reassembly . . . . .	3-43
Repair . . . . .	3-42
Bolt carrier and striker assembly:	
Cleaning . . . . .	2-25 3-22
Disassembly . . . . .	2-25 3-21
Inspection . . . . .	2-26 3-22
Location and description . . . . .	1-3 1-3
Maintenance . . . . .	2-24 3-21
PMCS . . . . .	2-4
Reassembly . . . . .	2-27 3-24
Repair . . . . .	2-26 3-22

Subject	Page 0* DS**
Service upon receipt . . . . .	2-1
Test . . . . .	3-24
Troubleshooting . . . . .	2-10, 3-3, 2-11 3-8.1
Breech bolt:	
Cleaning . . . . .	2-29 3-25
Disassembly . . . . .	2-28 3-25
Inspection . . . . .	2-29 3-26
installation . . . . .	3-27
Maintenance . . . . .	2-28 3-25
PMCS . . . . .	2-5
Reassembly . . . . .	2-30 3-27
Repair . . . . .	2-30
Repair/replacement . . . . .	3-27
Test . . . . .	3-27
Troubleshooting . . . . .	2-10.1 3-3, 2-10.2 3-6, 3-7, 3-8
C	
Capabilities and features . . . . .	1-2 1-2
Cartridge magazine . . . . .	1-3 1-3
Characteristics . . . . .	1-2 1-2
Charging handle assembly:	
Disassembly . . . . .	2-34
Inspection . . . . .	2-34
Installation . . . . .	2-35
Maintenance . . . . .	2-33
Reassembly . . . . .	2-35
Removal . . . . .	2-34
Repair . . . . .	2-34

\*0--Organizational  
\*\*DS--Direct Support

Subject	Page 0*	DS**
C		
Checking unpacked equipment . . . . .	2-2	
Cleaning (See individual assembly.)		
Cleaning, preservation, packing, and marking . . . . .	3-60	
Common tools and equipment . . . . .	1-2	1-2
D		
Description of major components . . . . .	1-3	1-3
Destruction of Army materiel to prevent enemy use . . . . .	1-1	1-1
Disassembly (See individual assembly.)		
Drive spring and guide assembly:		
Cleaning . . . . .	2-20	3-18
Inspection . . . . .	2-20	3-18
Location and description . . . . .	1-3	1-3
Maintenance . . . . .	2-19	3-17
Reassembly/installation . . . . .	2-21	3-18
Removal/disassembly . . . . .	2-19	3-17
Repair . . . . .	2-21	3-18
Troubleshooting . . . . .	2-9 2-10.1	3-2, 3-3, 3-4
E		
EIR's . . . . .	1-2	1-2
Equipment characteristics, capabilities, and features . . . . .	1-2	1-2

Subject	Page 0*	DS**
Equipment data . . . . .	1-3	1-3
Equipment description and data . . . . .	1-2	1-2
Expendable/durable supplies and materials list: . . . . .	D-1	D-1
Expendable/durable supplies and materials list . . . . .	D-2	D-2
Explanation of columns . . . . .	D-1	D-1
Introduction . . . . .	D-1	D-1
Scope . . . . .	D-1	D-1
F		
Fabricated items (See Illustrated list of manufactured items.)		
G		
General information . . . . .	1-1	1-1
H		
How to use this manual . . . . .	iv	iv
I		
Illustrated list of manufactured items: . . . . .	E-1	E-1
Introduction . . . . .	E-1	E-1
Manufactured items instructions . . . . .	E-2	E-2
Inspection (See individual assembly.)		
inspection points . . . . .		3-61
Installation (See individual assembly.)		

Subject	0*	Page	DS**
L			
Location and description of major components . . . . .	1-3	1-3	
Lower receiver and receiver extension assembly:			
Cleaning . . . . .	2-40		
Disassembly . . . . .	2-39	3-46	
Inspection . . . . .	2-41	3-49	
Location and description . . . . .	1-3	1-3	
Maintenance . . . . .	2-38	3-45	
PMCS . . . . .	2-7		
Reassembly . . . . .	2-41	3-52	
Repair . . . . .	2-41	3-51	
Test . . . . .		3-50, 3-59	
Troubleshooting . . . . .		3-2, 3-5, 3-8.1	
M			
MAC (See Maintenance allocation chart.)			
Maintenance allocation chart: . . . . .	B-1	B-1	
Explanation of columns in the MAC, section II . . . . .	B-2	B-2	
Explanation of columns in tool and test equipment requirements, section III . . . . .	B-3	B-3	
General . . . . .	B-1	B-1	
Introduction . . . . .	B-1	B-1	
Maintenance allocation chart . . . . .	B-4	B-4	

Subject	0*	Page	DS**
Maintenance functions . . . . .	B-1	B-1	
Tool and test equipment requirements . . . . .	B-6	B-6	
Maintenance forms, records, and reports . . . . .	1-1	1-1	
Maintenance procedures (Also see individual assemblies.) . . . . .	2-12	3-9	
Manufactured items (See Illustrated list of manufactured items.)			
Marking . . . . .			3-60
Metric chart (See inside back cover.)			
M231 submachine gun:			
Disassembly . . . . .	2-16		
Headspace test . . . . .			3-13
Inspection . . . . .	2-16	3-13	
Maintenance . . . . .	2-15	3-12	
Reassembly . . . . .	2-18		
Repair . . . . .	2-17		
Service upon receipt . . . . .	2-1		
Trigger pull test . . . . .			3-16
N			
National stock number and part number index . . . . .	I-1	I-1	
Nomenclature cross-reference list . . . . .	1-1	1-1	
O			
Official nomenclature, names, and designations . . . . .	1-1	1-1	

\*0--Organizational  
\*\*DS--Direct Support

Subject	0*	Page	DS**
O			
Organizational and direct support maintenance repair parts and special tools list: . . . . .		C-1	C-1
Abbreviations . . . . .		C-7	C-7
Explanation of columns . . . . .		C-1	C-1
General . . . . .		C-1	C-1
How to locate repair parts . . . . .		C-6	C-6
Introduction . . . . .		C-1	C-1
National stock number and part number index . . . . .		C-34	C-34
Repair parts list . . . . .		C-8	C-8
Scope . . . . .		C-1	C-1
Special information . . . . .		C-6	C-6
Special tools list . . . . .		C-32	C-32
P			
Packing . . . . .			3-60
Preembarkation inspection of materiel in units alerted for overseas movement: . . . . .			3-61
General . . . . .			3-61
inspection points . . . . .			3-61
Preinspection points . . . . .			3-61
Specific standards . . . . .			3-62
Preinspection points . . . . .			3-61
Preparation for storage or shipment . . . . .	1-1		1-1, 3-60
Preservation . . . . .			3-60

Subject	0*	Page	DS**
Preventive maintenance checks and services (PMCS) . . . . .			2-3
Principles of operation . . . . .			1-4 1-4
Q			
Quarterly preventive maintenance checks and services . . . . .			2-3
R			
Reassembly (See individual assembly.)			
References . . . . .			A-1 A-1
Removal (See individual assembly.)			
Repair (See individual assembly.)			
Repair parts . . . . .			1-2 1-2
Repair parts list . . . . .			C-8 C-8
Repair parts and special tools list (See Organizational and direct support maintenance repair parts and special tools list.)			
Reporting equipment improvement recommendations (EIR) . . . . .			1-2 1-2
Reporting errors and recommending improvements . . . . .			i i

Subject	0* Page	DS**
Retainer assembly:		
Cleaning . . . . .	2-22	3-20
Disassembly . . . . .	2-22	3-20
Inspection . . . . .	2-23	3-20
Installation . . . . .		3-20
Maintenance . . . . .	2-22	3-19
Reassembly . . . . .	2-23	3-20
Repair . . . . .	2-23	
Repair/replacement . . . . .		3-20
RPSTL (See Organizational and direct support maintenance repair parts and special tools list.)		
S		
Service upon receipt:		
Scope . . . . .	2-1	
Service upon receipt of materiel . . . . .	2-1	
Table . . . . .	2-1	
Special tools . . . . .	1-2	1-2
Special tools list . . . . .	C-32	C-32
Standards for preembarkation inspection in units alerted for overseas movement . . . . .		3-62
Storage, preparation for . . . . .		3-60
Support equipment . . . . .	1-2	1-2

Subject	0* Page	DS**
T		
Table of contents . . . . .	i	i
Test (See individual assembly.)		
TMDE . . . . .	1-2	1-2
Tool and test equipment requirements . . . . .	B-6	B-6
Troubleshooting:		
Symptom index . . . . .	2-8	3-1
Troubleshooting information . . . . .	2-8	3-1
Troubleshooting table . . . . .	2-8	3-2

U		
Unit pack . . . . .		3-60
Upper receiver assembly:		
Cleaning . . . . .	2-36	
Disassembly . . . . .	2-36	3-39
Inspection . . . . .	2-37	
Inspection/cleaning . . . . .		3-40
Maintenance . . . . .	2-35	3-39
PMCS . . . . .	2-6	
Reassembly . . . . .	2-38	3-41
Repair . . . . .	2-37	3-40

\*()--Organizational  
\*\*DS--Direct support

# Index 6

TM 9-1005-309-23&P

Subject	0*	Page	DS**
U			
Upper receiver and barrel assembly:			
Barrel erosion test .....		3-37	
Barrel straightness test .....		3-33	
Chamber test .....		3-32	
Disassembly .....	2-31	3-29	
Headspace test .....		3-38	
Inspection .....	2-32		
Inspection/cleaning .....		3-32	
Location and description .....	1-3	1-3	

Subject	0*	Page	DS**
Maintenance .....	2-31		3-28
PMCS .....	2-5		
Reassembly .....	2-32		3-33
Repair .....	2-32		3-33
Troubleshooting .....			3-2, 3-6, 3-7,
W			
Warning page .....	a		a

---

\*0--Organizational  
 \*\*DS--Direct Support

RECOMMENDED CHANGES TO EQUIPMENT TECHNICAL PUBLICATIONS



THEN, JOT DOWN THE DOPE ABOUT IT ON THIS FORM. CAREFULLY TEAR IT OUT. FOLD IT AND DROP IT IN THE MAIL.

**SOMETHING WRONG WITH THIS PUBLICATION?**

FROM: (PRINT YOUR UNIT'S COMPLETE ADDRESS)

Your mailing address

DATE SENT

Date you filled out this form

PUBLICATION NUMBER

TM 9-1005-309-23&P

PUBLICATION DATE

3 Mar 83

PUBLICATION TITLE Org and DS Maint Manual w/RPSTL for M231 Sub-machine Gun

BE EXACT PIN-POINT WHERE IT IS

PAGE NO	PARA-GRAPH	PICTURE NO	TABLE NO
2-25	2-11		
3-4	3-1		

IN THIS SPACE TELL WHAT IS WRONG AND WHAT SHOULD BE DONE ABOUT IT:

*Callouts 5 and 4 should be reversed.*

*Performed all steps for malfunction 5, weapon still does not cock.*

SAMPLE

PRINTED NAME, GRADE OR TITLE, AND TELEPHONE NUMBER

SIGN HERE

Your name

DA FORM 2028-2  
1 JUL 79

PREVIOUS EDITIONS ARE OBSOLETE.

P.S.—IF YOUR OUTFIT WANTS TO KNOW ABOUT YOUR RECOMMENDATION MAKE A CARBON COPY OF THIS AND GIVE IT TO YOUR HEADQUARTERS





FILL IN YOUR  
UNIT'S ADDRESS

FOLD BACK

DEPARTMENT OF THE ARMY

POSTAGE AND FEES PAID  
DEPARTMENT OF THE ARMY  
DOD 314



TEAR ALONG PERFORATED LINE

OFFICIAL BUSINESS  
PENALTY FOR PRIVATE USE \$300

Commander  
US Army Armament Materiel Readiness Command  
ATTN: DRSAR-MAS  
Rock Island, IL 61299



FILL IN YOUR  
UNIT'S ADDRESS

FOLD BACK

DEPARTMENT OF THE ARMY

POSTAGE AND FEES PAID  
DEPARTMENT OF THE ARMY  
DOD 314



OFFICIAL BUSINESS  
PENALTY FOR PRIVATE USE \$300

Commander  
US Army Armament Materiel Readiness Command  
ATTN: DR SAR-MAS  
Rock Island, IL 61299

TEAR ALONG PERFORATED LINE

RECOMMENDED CHANGES TO EQUIPMENT TECHNICAL PUBLICATIONS



THEN JOT DOWN THE DOPE ABOUT IT ON THIS FORM. CAREFULLY TEAR IT OUT. FOLD IT AND DROP IT IN THE MAIL.

**SOMETHING WRONG WITH THIS PUBLICATION?**

FROM: (PRINT YOUR UNIT'S COMPLETE ADDRESS)

DATE SENT

PUBLICATION NUMBER

TM 9-1005-309-23&P

PUBLICATION DATE

3 Mar 83

PUBLICATION TITLE Org and DS Maint Manual w/RPSTL for M231 Sub-machine Gun

BE EXACT PIN-POINT WHERE IT IS

PAGE NO	PARA-GRAPH	FIGURE NO	TABLE NO

IN THIS SPACE TELL WHAT IS WRONG AND WHAT SHOULD BE DONE ABOUT IT:

PRINTED NAME, GRADE OR TITLE, AND TELEPHONE NUMBER

SIGN HERE

DA FORM 2028-2  
1 JUL 79

PREVIOUS EDITIONS ARE OBSOLETE.

P.S. --IF YOUR OUTFIT WANTS TO KNOW ABOUT YOUR RECOMMENDATION MAKE A CARBON COPY OF THIS AND GIVE IT TO YOUR HEADQUARTERS

FILL IN YOUR  
UNIT'S ADDRESS

FOLD BACK

DEPARTMENT OF THE ARMY

POSTAGE AND FEES PAID  
DEPARTMENT OF THE ARMY  
DOD 314



TEAR ALONG PERFORATED LINE

OFFICIAL BUSINESS  
PENALTY FOR PRIVATE USE \$300

Commander  
US Army Armament Materiel Readiness Command  
ATTN: DRSAR-MAS  
Rock Island, IL 61299

By Order of the Secretary of the Army:

*official:*

ROBERT M. JOYCE  
*Major General, United States Army*  
*The Adjutant General*

E. C. MEYER  
*General, United States Army*  
*Chief of Staff*

DISTRIBUTION:

To be distributed in accordance with DA Form 12-37, Organizational Maintenance requirements for IFV Firing Port Weapon M231.



METRIC CHART

UNITS OF MEASURE

When units of length, distance, temperature, weight, torque, or volume are used in this manual, both US customary and metric units are shown. US customary units are shown first with the equal metric units shown in parentheses. Units of time and angle are the same for US customary and metric systems. No equal units are shown for seconds, minutes, hours, degrees

of angle, or roils. When units identify ammunition, they stand alone. Also, describe tools or parts which are not only one kind of unit is used. The the difference between US customary It also shows the symbols used for

US CUSTOMARY

LENGTH AND DISTANCE

inch: 1 in. ....
foot: 1 ft ....
yard: 1 yd .....

TEMPERATURE

degree Fahrenheit: °F ..... (F°-32°) x 5/9

WEIGHT

pound: 1 lb .....

TORQUE

inch-pound: 1 in.-lb ..... 0.1
foot-pound: 1 ft-lb ..... 1.35

VOLUME

ounce: 1 oz .....
pint: 1 pt .....
quart: 1 qt .....
gallon: 1 gal. ....

