

SUPERSEDES COPY DATED 18 NOVEMBER 1986  
SEE PAGE i FOR DETAILS

## TECHNICAL MANUAL

ORGANIZATIONAL AND DIRECT SUPPORT  
MAINTENANCE MANUAL (INCLUDING REPAIR PARTS  
AND SPECIAL TOOLS LIST)

FOR  
BAYONET-KNIFE, M6, WITH BAYONET-KNIFE  
SCABBARD, M10 (1095-00-014-0369),

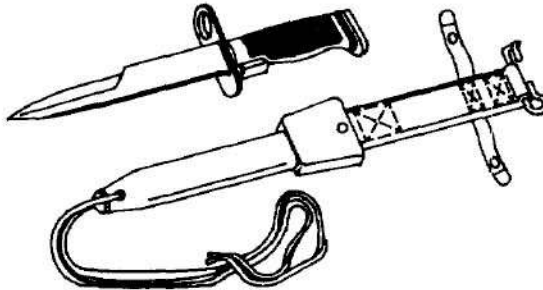

BAYONET-KNIFE, M7, WITH BAYONET-KNIFE  
SCABBARD, M10 (1095-00-017-9701) AND

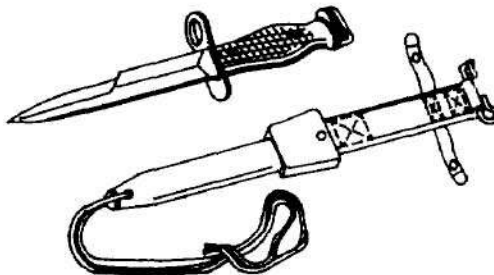

M9 MULTIPURPOSE BAYONET SYSTEM (1005-01-227-1739)

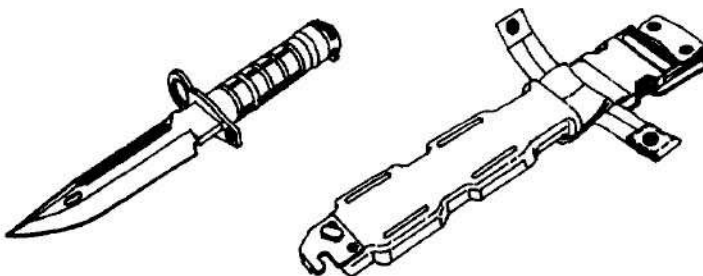

DISTRIBUTION STATEMENT A: Approved for public release; distribution is unlimited.

HEADQUARTERS, DEPARTMENT OF THE ARMY

JANUARY 1993

WARNING

The bayonet blade is sharp. Handle with care.

When utilizing the M9 Multipurpose Bayonet System as a wire cutter, be sure to keep hands/fingers away from blade.

The M9 Multipurpose Bayonet System is not insulated against electric shock. Do not use it to cut live wires.

Keep tip of blade pointed away from body at all times.

To avoid injury while tightening tang, clamp blade in a padded jaw vice.

Dry cleaning solvent (A-A-711) is flammable and should not be used near an open flame or in a smoking area. Use only in well-ventilated areas. This solvent evaporates quickly and has a drying effect on the skin. When used without gloves, it may irritate, inflame or cause cracks in the skin.

When using solid film lubricant, be sure area is well ventilated.

To avoid injury to your eyes, be careful when removing and installing spring-loaded parts.

In the event of nuclear, biological or chemical (NBC) contamination, remove the sharpening stone of the M9 Multipurpose Bayonet System and discard prior to implementing decontamination procedures. Removal at any other time (except for replacement) is not authorized.

The scabbard should be securely tied down to the leg when parachute jumping.

FIRST AID

For further information on first aid, see FM 21-11.

TECHNICAL MANUAL

HEADQUARTERS  
DEPARTMENT OF THE ARMY  
11 January 1993

No. 9-1005-237-23&P

Washington, DC

ORGANIZATIONAL AND DIRECT SUPPORT MAINTENANCE MANUAL  
(INCLUDING REPAIR PARTS AND SPECIAL TOOLS LIST)

FOR

BAYONET-KNIFE, M6, WITH BAYONET-KNIFE  
SCABBARD, M10  
(1005-00-014-0369)

BAYONET-KNIFE, M7, WITH BAYONET-KNIFE  
SCABBARD, M10  
(1005-00-017-9701)

AND

M9 MULTIPURPOSE BAYONET SYSTEM  
(1005-01-227-1739)

Current as of 10 June 1992

REPORTING ERRORS AND RECOMMENDING IMPROVEMENTS

You can help improve this manual. If you find any mistakes or if you know of a way to improve the procedures, please let us know. Mail your letter, DA Form 2028 (Recommended Changes to Publications and Blank Forms), or DA Form 2028-2 located in the back of this manual direct to: Commander, US Army Armament, Munitions and Chemical Command, ATTN: AMSMC-MAS, Rock Island, IL 61299-6000. A reply will be furnished to you.

Distribution Statement A: Approved for public release; distribution is unlimited.

TABLE OF CONTENTS

	Page
CHAPTER I INTRODUCTION	
Section I General Information . . . . .	1-1
Section II Equipment Description and Data . . . . .	1-1

\*This manual supersedes TM 9-1005-237-23&P, 18 November 1986, including all changes.

TABLE OF CONTENTS (Cont)

	Page	Illus/ Figure
CHAPTER 2 ORGANIZATIONAL MAINTENANCE INSTRUCTIONS		
Section I Repair Parts, Special Tools; Test, Measurement, and Diagnostic Equipment (TMDE); and Support Equipment . . . . .	2-1	
Section II Service Upon Receipt. . . . .	2-1	
Section III Preventive Maintenance Checks and Services (PMC3) .	2-5	
Section IV Maintenance Instructions . . . . .	2-11	
CHAPTER 3 DIRECT SUPPORT MAINTENANCE INSTRUCTIONS		
Section I Maintenance Procedures . . . . .	3-1	
APPENDIX A REFERENCES. . . . .	A-1	
APPENDIX B MAINTENANCE ALLOCATION CHART		
Section I Introduction. . . . .	B-1	
Section II Maintenance Allocation Chart for M6 Bayonet-knife with Scabbard, M7 Bayonet-knife with Scabbard and M9 Multipurpose Bayonet System . . . . .	B-4	
Section III Tool and Test Equipment Requirements for M6 Bayonet-knife with Scabbard, M7 Bayonet-knife with Scabbard and M9 Multipurpose Bayonet System . . . . .	B-6	
APPENDIX C ORGANIZATIONAL AND DIRECT SUPPORT MAINTENANCE REPAIR PARTS AND SPECIAL TOOLS LIST		
Section I Introduction. . . . .	C-1	
Section II Repair Parts List . . . . .	C-1-1	
Group 00 Bayonet-knife with M10 Scabbard, M6 8427015 & M7 8427025 & M9 Multipurpose Bayonet System 12011860. . . . .	C-1-1	C-1
Group 01 Bayonet-knife, M6 7267616. . . . .	C-2-1	C-2
Group 02 Bayonet-knife, M7 11010077 . . . . . ,	C-3-1	C-3
0201 Blade Assembly, M7 11010067 . . . . .	C-4-1	C-4
Group 03 Scabbard, Bayonet-knife, M10 8&48476. . . . .	C-5-1	C-5
Group 04 Bayonet-knife Assembly, M9 12011861. . . . .	C-6-1	C-6
0401 Latch Assembly 12598168. . . . .	C-7-1	C-7
Group 05 Scabbard, Bayonet-knife M9 12011862. . . . .	C-8-1	C-8
0501 Attaching Assembly 12598193 . . . . .	C-9-1	C-9
0502 Scabbard, Body Assembly 12598184 , . . . .	C-10-1	C-10
Section III Special Tools List (not applicable)		
Section IV National Stock Number and Part Number index	I-1	
APPENDIX D EXPENDABLE/DURABLE SUPPLIES AND MATERIALS LIST		
Section I Introduction. . . . .	D-1	
Section II Expendable/Durable Supplies and Materials List . . . .	D-2	
ALPHABETICAL INDEX . . . . .	Index 1	

## CHAPTER 1 INTRODUCTION

## SECTION I. GENERAL INFORMATION

## 1-1. SCOPE

a. Type of Manual. Organizational and Direct Support (DS) Maintenance.

b. Model Numbers and Equipment Names. M6 Bayonet-knife, M7 Bayonet-knife, M10 Bayonet-knife Scabbard and M9 Multipurpose Bayonet System.

c. Purpose of Equipment. The M6 Bayonet-knife is used as a bayonet on the M14 Rifle series and as a hand weapon. The M7 Bayonet-knife is used as a bayonet on the M16 Rifle series, the M4 Carbine and as a hand weapon. The M9 Multipurpose Bayonet System is used as a bayonet on the M16 Rifle series, on the M4 Carbine, as a hand weapon, as a general field and utility knife as well as a wire cutter together with its scabbard, and as a saw.

1-2. MAINTENANCE FORMS, RECORDS AND REPORTS. Department of the Army forms and procedures used for equipment maintenance will be those prescribed by DA PAM 738-750, The Army Maintenance Management System (TAMMS).

1-3. DESTRUCTION OF ARMY MATERIEL TO PREVENT ENEMY USE. Refer to TM 750-244-7 for procedures concerning destruction of this materiel.

1-4. PREPARATION FOR STORAGE OR SHIPMENT. Refer to SB 740-95-1 for storage or shipment instructions.

1-5. REPORTING EQUIPMENT IMPROVEMENT RECOMMENDATIONS (EIR). If your M6 Bayonet-knife, M7 Bayonet-knife, M10 Bayonet-knife Scabbard or M9 Multipurpose Bayonet System needs improvement, let us know. Send us an EIR. You, the user, are the only one who can tell us what you don't like about your equipment. Let us know why you don't like the design. Put it on an SF 368 (Quality Deficiency Report). Mail it to us at: Commander, US Army Armament, Munitions and Chemical Command, ATTN : AMSMC-QAD, Rock Island, IL 61299-6000. We'll send you a reply.

1-6. CORROSION PREVENTION. Instructions on corrosion prevention are found in paragraphs 2-4, 2-5, 2-7, 2-8, 2-9.A, 2-9.B, 2-10, 2-11.A, 2-11.B, 2-11.C, 2-11.D, 3-1, 3-2, 3-3, and 3-4.

## Section II. EQUIPMENT DESCRIPTION AND DATA

## 1-7. DIFFERENCES BETWEEN MODELS.

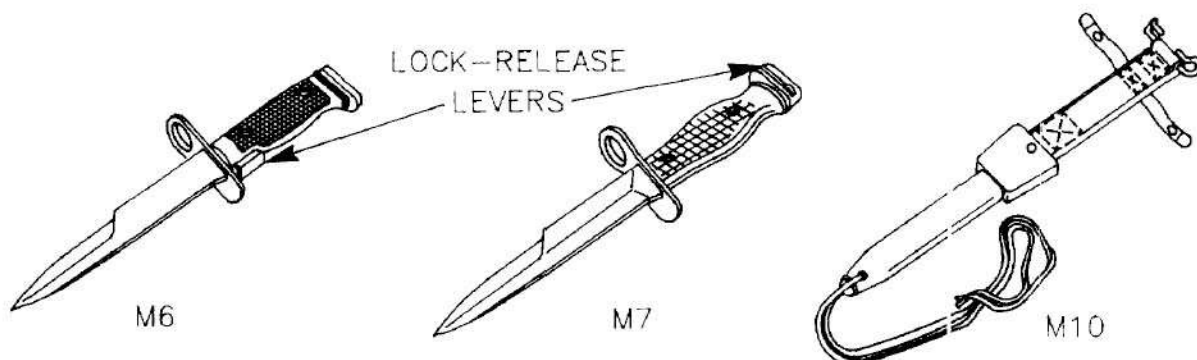

## 1-7. DIFFERENCES BETWEEN MODELS. (cont)

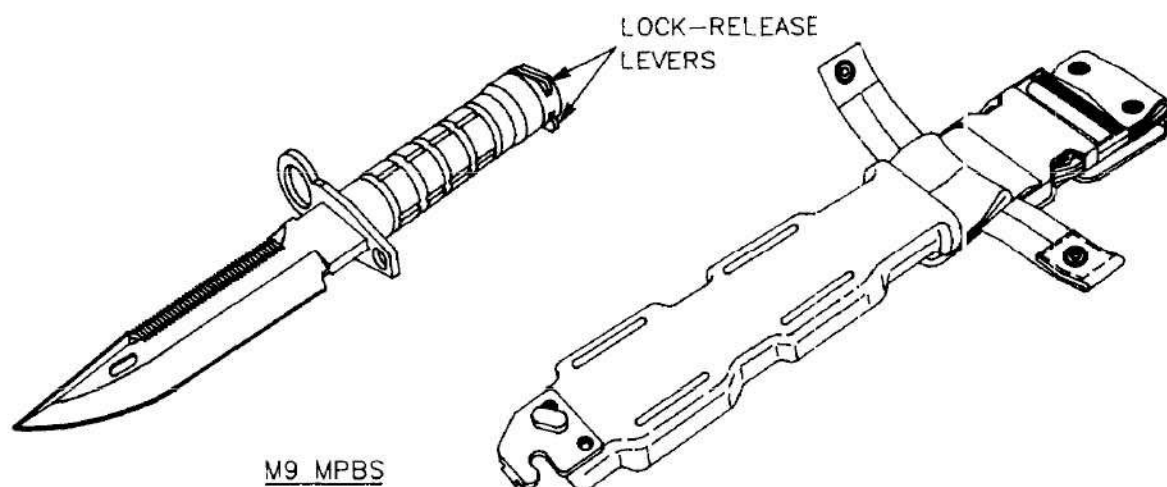

a. The M6 Bayonet-knife is used on the 7.62-mm M14 rifle series. The M7 Bayonet-knife is used on the 5.56-mm M16 rifle series and the M4 Carbine. The two models cannot be interchanged. The M9 Multipurpose Bayonet System is used on the M16 rifle series and the M4 Carbine. The M9 cannot be interchanged with the M6. The M9 is a replacement for some M7 Bayonet-knives.

b. The predominant physical difference between the M6 and M7 is the lock-release levers. On the M6 Bayonet-knife the lock-release lever is a single lever located on the bottom of the grip at the rear of the blade guard. On the M7 and M9 Bayonet-knives there are left- and right-hand lock-release levers at the rear of the bayonet. The M9 is longer and wider (blade is over 7 inches long and 1.4 inches wide) and heavier than either the M6 or M7.

c. Interchangeability of parts is limited to the grip screws on the M6 and M7. The lock-release levers and springs are common for the M7 and M9.

d. The M9 Multipurpose Bayonet System scabbard consists of four major parts: the scabbard body, wire cutter plate, attaching assembly lead bearing end, and attaching assembly scabbard end. The M10 Bayonet-knife Scabbard is a single piece.

## CHAPTER 2 ORGANIZATIONAL MAINTENANCE INSTRUCTIONS

## Section I. REPAIR PARTS, SPECIAL TOOLS; TEST, MEASUREMENT AND DIAGNOSTIC EQUIPMENT (TMDE); AND SUPPORT EQUIPMENT

2-1. COMMON TOOLS AND EQUIPMENT. For authorized common tools and equipment refer to the Modified Table of Organization and Equipment (MTOE) applicable to your unit.

2-2. SPECIAL TOOLS, TMDE AND SUPPORT EQUIPMENT. There are no special tools, TMDE or support equipment.

2-3. REPAIR PARTS. Repair parts are listed and illustrated in appendix C of this manual.

## Section II. SERVICE UPON RECEIPT

2-4. GENERAL. This section contains instructions for services to be performed by the using organization upon the receipt of a new M6 Bayonet-knife with scabbard, M7 Bayonet-knife with scabbard or M9 Multipurpose Bayonet System.

## NOTE

a. Where the word "lubricant" is cited in this TM, interpret to mean Cleaner Lubricant and Preservative (CLP) (app D, item 3), Lubricating Oil, Weapons Semi-fluid (LSA) (app D, item 10), or Lubricating Oil Weapons (LAW) (app D, item 9) can be utilized as applicable. The following constraints must be adhered to:

b. Under all but the coldest arctic conditions, LSA or CLP are the lubricants to use on the bayonet/scabbard. Either can be used at  $-10^{\circ}\text{F}$  and above. However, do not use both on the same bayonet/scabbard at the same time.

c. LAW is the lubricant to use during cold arctic conditions,  $+10^{\circ}\text{F}$  and below.

d. Any of the lubricants can be used from  $-10^{\circ}\text{F}$  to  $+10^{\circ}\text{F}$ .

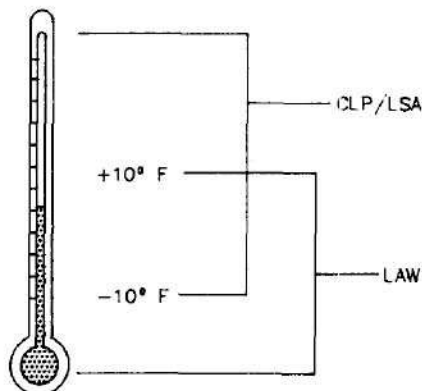

e. Do not mix lubricants on the same bayonet/scabbard. The bayonet/scabbard must be thoroughly cleaned during change from one lubricant to another. Dry Cleaning Solvent (SD) (app D, item 5) is recommended for cleaning the bayonet during change from one lubricant to another. Do not use SD on the scabbard or the handle.

## 2-5. SERVICE UPON RECEIPT OF MATERIEL.

## WARNING

The blade of the bayonet is extremely sharp. Handle with care.

Table 2-1. SERVICE UPON RECEIPT- M6 BAYONET-KNIFE WITH M10 SCABBARD, M7 BAYONET-KNIFE WITH M10 SCABBARD AND M9 MULTIPURPOSE BAYONET SYSTEM

Location	Item	Action	Remarks
1. M6 Bayonet-knife or M7 Bayonet-knife	M6 Bayonet-knife or M7 Bayonet-knife	<ul style="list-style-type: none"> <li>a. Check for nicks and broken point.</li> <li>b. Remove grips and inspect bayonet for rust.</li> <li>c. Inspect grips for cracks.</li> <li>d. Check function of lock-release levers.</li> <li>e. Place bayonet on rifle bayonet lug. Ensure bayonet is securely retained and mounts/dismounts without interference.</li> <li>f. Apply light film of lubricant to metal components.</li> </ul>	Refer to paragraph 2-9.A. for all inspection criteria.
2. M10 Bayonet-knife Scabbard	M10 Bayonet-knife Scabbard	<ul style="list-style-type: none"> <li>a. Check for cracks and worn fabric.</li> <li>b. Check function of snaps.</li> <li>c. Ensure that scabbard restraining lace is present.</li> <li>d. Apply light film of lubricant to metal components.</li> </ul>	

## 2-5. SERVICE UPON RECEIPT OF MATERIEL. (cont)

Table 2-1. SERVICE UPON RECEIPT - M6 BAYONET-KNIFE WITH M10 SCABBARD, M7 BAYONET-KNIFE WITH M10 SCABBARD AND M9 MULTIPURPOSE BAYONET SYSTEM (Cont)

Location	Item	Action	Remarks
3. M9 Multi-purpose Bayonet System-Bayonet	M9 Multi-purpose Bayonet System-Bayonet	<ul style="list-style-type: none"> <li>a. Check function of lock-release levers by placing bayonet on rifle lug. Ensure bayonet is securely retained and mounts and dismounts without interference.</li> <li>b. Inspect blade for cracks, nicks or blunted point.</li> <li>c. Inspect/check handguard for cracks or looseness.</li> <li>d. Inspect handle for cracks, breaks or looseness.</li> <li>e. Inspect for broken or dulled saw teeth.</li> <li>f. Inspect for broken, cracked or chipped "false edge" on blade.</li> <li>g. Remove cap screw and latch assembly. Check for rust.</li> <li>h. Inspect for loose, cracked or broken cap screw.</li> <li>i. Apply light film of lubricant to metal components.</li> </ul>	Refer to paragraph 2-11.A. for all inspection criteria.

## 2-5. SERVICE UPON RECEIPT OF MATERIEL. (cont)

Table 2-1. SERVICE UPON RECEIPT - M6 BAYONET-KNIFE WITH M10 SCABBARD, M7 BAYONET-KNIFE WITH M10 SCABBARD AND M9 MULTIPURPOSE BAYONET SYSTEM (Cont)

Location	Item	Action	Remarks
4. M9 Multi-purpose Bayonet System-Scabbard	M9 Multi-purpose Bayonet System-Scabbard	a. Inspect for cracks, cut or worn fabric or web gear. b. Inspect for cracked or broken buckle of attaching assembly. c. Inspect for cracked or broken scabbard body. d. Inspect for bent or broken belt fastener. e. Inspect for cracked or broken screwdriver tip or wire cutter plate/stud. f. Inspect for broken or missing sharpening stone. g. Inspect snaps to insure they function. h. Apply light film of lubricant to metal components.	Refer to paragraph 2-11.C for all inspection criteria.

## 2-6. CHECKING UNPACKED EQUIPMENT.

- a. Inspect the equipment for damage incurred during shipment. If the equipment has been damaged, report the damage on SF Form 364, Report of Discrepancy (ROD).
- b. Check the equipment against the packing slip to see if the shipment is complete. Report all discrepancies in accordance with the instructions of DA PAM 738-750.
- c. Check to see whether the equipment has been modified.

## Section III. PREVENTIVE MAINTENANCE CHECKS AND SERVICES (PMCS)

## 2-7. GENERAL.

a. To ensure maximum operational readiness, it is necessary that the M6 Bayonet-knife, M7 Bayonet-knife, M10 Bayonet-knife Scabbard and M9 Multipurpose Bayonet System be systematically inspected at regular intervals so defects may be discovered and corrected before they result in serious damage or failure.

b. During periods of inactivity, perform PMCS quarterly unless inspection reveals more frequent servicing is necessary. An inactive bayonet is one which has been stored in an arms room for a period of 90 days without use. The bayonet may or may not have been assigned to an individual. Normal cleaning (PMCS) of an inactive bayonet will be performed every 90 days. Should the unit armorer detect corrosion on a bayonet/scabbard prior to the end of the 90-day period, the PMCS shall be performed immediately.

2-8. PREVENTIVE MAINTENANCE CHECKS AND SERVICES. Table 2-1. lists those preventive maintenance checks and services (PMCS) to be performed at their designated intervals.

a. Column 1, Item No. The first column contains the item number which shall be used as a source of item numbers for the TM Number Column on DA Form 2404, Equipment Inspection and Maintenance Worksheet, in recording results of PMCS. Checks and services are numbered in disassembly sequence.

b. Column 2, item to be inspected. The second column lists the item to be inspected.

c. Column 3, Procedures. The third column contains all the information required to accomplish the checks and services.

d. Column 4, Not Fully Mission Capable If. This column contains a brief statement of the condition (e.g. , malfunction, shortcoming (SH) or deficiency (1)) that would cause the covered equipment to be less than fully ready to perform its assigned mission.

## NOTE

For the purpose of this technical manual, the following definitions are supplied. These definitions are not intended to apply to any other document.

Shortcoming (SH): A fault that requires maintenance or supply action on a piece of equipment, but does not render equipment Not Mission Capable.

Deficiency (D): A fault or problem that causes equipment to malfunction. Faults that make the equipment Not Mission Capable are deficiencies.

A deficiency deadlines the weapon.

2-8. PREVENTIVE MAINTENANCE CHECKS AND SERVICES (Cont).

WARNING

The bayonet blade is sharp. Handle it with care and discretion.

NOTE

For use of lubricant refer to paragraph 2-4.

Repair as authorized. If repair not authorized, evacuate to D. S. Maintenance.

Table 2-2. ORGANIZATIONAL PREVENTIVE MAINTENANCE CHECKS AND SERVICES QUARTERLY SCHEDULE

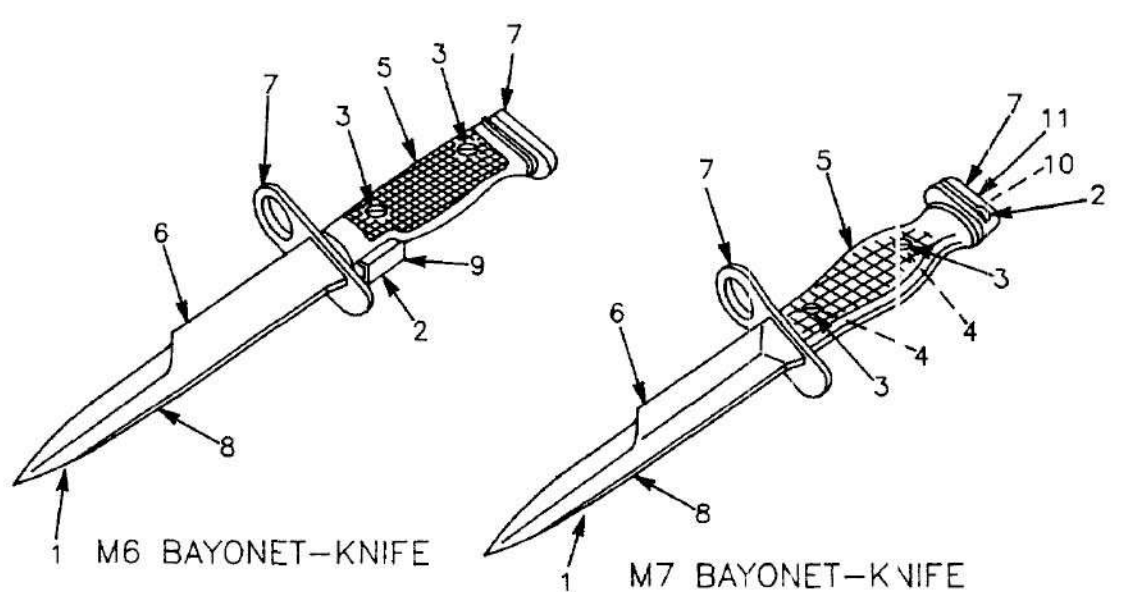
Item NO.	Item To Be Inspected	Procedures	Not Fully Mission Capable If:
	 <p>1 M6 BAYONET-KNIFE</p> <p>1 M7 BAYONET-KNIFE</p>	<p>Inspect for missing parts.</p> <p>Check function of lock-release levers by placing bayonet on rifle lug. Ensure bayonet is securely retained and mounts/dismounts without interference. Remove bayonet from rifle and disassemble as authorized.</p>	<p>D - if parts are missing</p> <p>D - Bayonet is not securely retained</p>

## 2-8. PREVENTIVE MAINTENANCE CHECKS AND SERVICES. (cont)

Table 2-2. ORGANIZATIONAL PREVENTIVE MAINTENANCE CHECKS AND SERVICES  
QUARTERLY SCHEDULE (Cont)

Item No.	Item To Be Inspected	Procedures	Not Fully Mission Capable If:
3		Inspect grip screws for stripped or damaged threads. Check grip screw head for burrs.	D - Grip screw threads are stripped or damaged SH - Grip screw head has burrs
4		Inspect lock washers for set or damage on the M7.	SH - Lock washers have taken set or are damaged
5		Inspect grips for cracks and stripped threads. Hairline cracks and cracks up to 1/4 inch in length are acceptable. Chips up to 1/8 inch in diameter are acceptable.	D - Stripped threads or cracks longer than 1/4 inch SH - Chips over 1/8 inch in diameter
6		Inspect blade assembly for cracks, nicks or blunted/broken points. Nicks and blunted/broken points may be stoned. If nicks and blunted/broken points cannot be corrected by stoning, evacuate to D.S. Maintenance	D - Blade is cracked D - Blade is less than 6-1/8 inches long from handguard SH - Blade is nicked or point blunted
7		Inspect/check guard area of blade assembly and plate area of blade assembly for looseness.	SH - Guard or plate are loose
8		Inspect for worn or shiny areas on blade assembly.	SH - Blade is worn or shiny

2-8. PREVENTIVE MAINTENANCE CHECKS AND SERVICES. (cont)

Table 2-2. ORGANIZATIONAL PREVENTIVE MAINTENANCE CHECKS AND SERVICES  
QUARTERLY SCHEDULE (Cont)

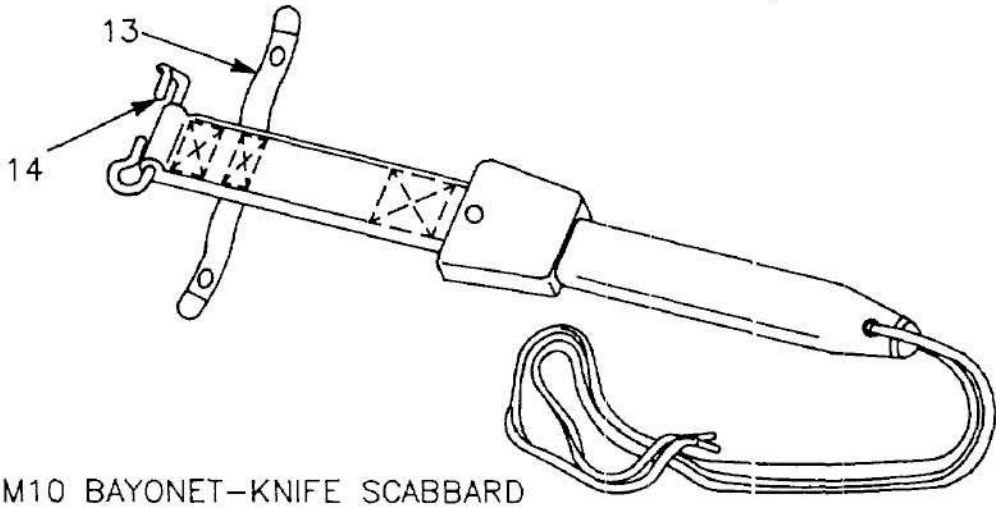
Item No.	Item To Be Inspected	Procedures	Not Fully Mission Capable If:
9	M6 Bayonet-knife and M7 Bayonet-knife (cont)	Inspect M6 lock-release lever for bends and wear.	D - Lock-release lever is bent or worn and not fully functional
10		Inspect compression helical spring for kinks, set and breaks.	D - Compression helical spring is kinked, set or broken
11		Inspect spring pin for burrs or wear	D - Spring pin doesn't retain its associated part
12		Inspect all parts for rust/corrosion	SH - part is rusted/corroded
 <p>M10 BAYONET-KNIFE SCABBARD</p>			
13	M10 bayonet-knife scabbard	Check for cracks, cut/torn fabric, missing lace and function of snap. Cracks 1/2 inch or less are not cause for repair.	D - Crack is over 1/2 inch long or snap does not function SH - Cuts/tears in fabric over 1/4 inch deep, or missing lace
14		Check metal parts for damage or corrosion.	D - Part is not functional SH - Part is corroded

2-8. PREVENTIVE MAINTENANCE CHECKS AND SERVICES. (cont)

Table 2-2. ORGANIZATIONAL PREVENTIVE MAINTENANCE CHECKS AND SERVICES  
QUARTERLY SCHEDULE (Cont)

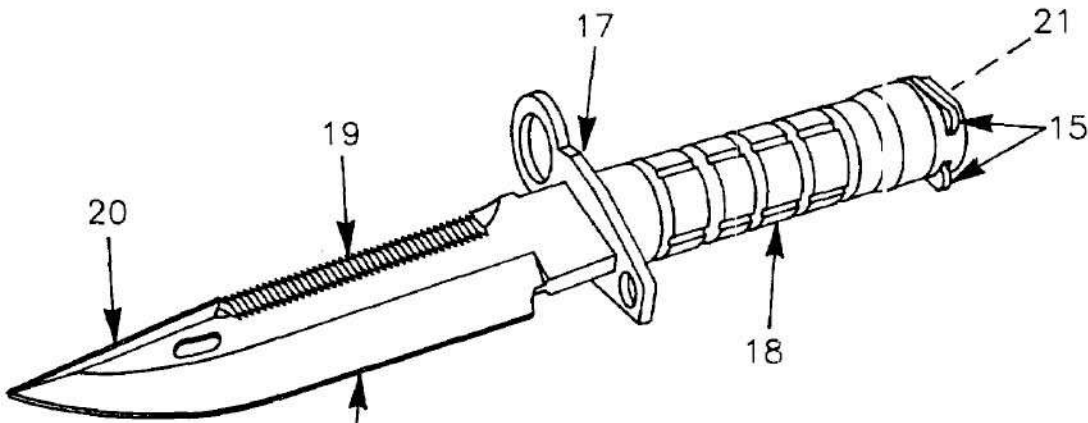
Item No.	Item To Be Inspected	Procedures	Not Fully Mission Capable If:
 <p style="text-align: center;"><u>M9 MPBS</u></p>			
15	M9 Multipurpose Bayonet	Check function of lock-release levers by placing bayonet on rifle lug. Ensure bayonet is securely retained and mounts and dismounts without interference. Remove bayonet from rifle.	D - Bayonet is not securely retained or interference is observed during installing or removal
16		Inspect blade for cracks, nicks or blunted point. If stoning doesn't restore blade evacuate to D.S Maintenance.	D - Blade is cracked D - Blade is less than 6 3/4 inches long from hand-guard SH - Blade is nicked or point blunted and cannot be restored by stoning
17		Inspect/check handguard for cracks or looseness. If loose, tighten cap screw.	D - Handguard is cracked or hand-guard cannot be tightened

2-8. PREVENTIVE MAINTENANCE CHECKS AND SERVICES. (cont)

Table 2-2. ORGANIZATIONAL PREVENTIVE MAINTENANCE CHECKS AND SERVICES  
QUARTERLY SCHEDULE (Cont)

Item No.	Item To Be Inspected	Procedures	Not Fully Mission Capable If:
18		Inspect handle for cracks, breaks or looseness. If loose, tighten cap screw. Chips up to 1/8 inch diameter are acceptable.	D - Handle is cracked more than 1/2 inch or handle cannot be tightened SH - Handle is chipped more than 1/8 inch in diameter
19		Inspect for broken or dulled saw teeth.	SH - If 1/4 of saw teeth are broken, badly worn or nonfunctional
20		Inspect for broken, cracked or chipped "false edge" on blade.	D -- "False edge" is broken or cracked SH - "False edge" is chipped beyond functioning
21		Inspect for loose, cracked or broken cap screw.	D - Cap screw cannot be tightened or cap screw is cracked or broken

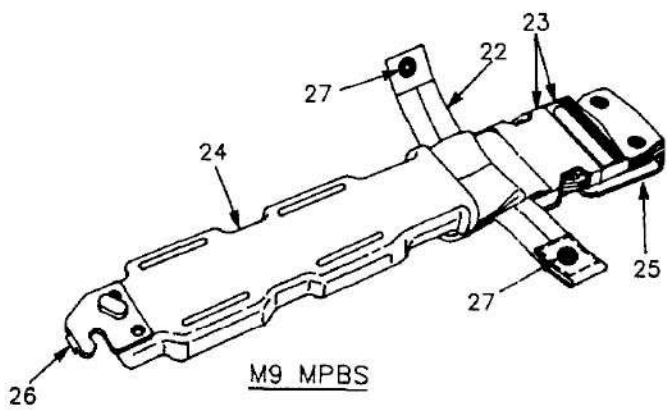

22	M9 Scabbard	Inspect for cut web gear or restraining strap. Cuts 1/4 inch in length or less are not cause for repair.	SH - Cuts over 1/4 inch deep
23		Inspect for cracked or broken FASTEX buckle.	D - FASTEX buckle is cracked or broken

2-8. PREVENTIVE MAINTENANCE CHECKS AND SERVICES. (cont)

Table 2-2. ORGANIZATIONAL PREVENTIVE MAINTENANCE CHECKS AND SERVICES  
QUARTERLY SCHEDULE (Cont)

Item No.	Item To Be Inspected	Procedures	Not Fully Mission Capable If:
24	M9 Scabbard (Cont)	Inspect for cracked or broken scabbard body. Cracks less than 1/2 inch in length are not cause for repair. Missing pieces less than 1/8 inch in diameter are not cause for repair.	D - Scabbard body has cracks over 1/2 inch long or has missing pieces over 1/8 inch in diameter
25		Inspect for bent or broken belt fastener.	D - Belt fastener will not securely fasten the scabbard to the belt
26		Inspect for cracked or broken screw driver tip or wire cutter plate/stud.	D - Cutter plate/stud will not cut wire SH - Screw driver is unable to remove bayonet cap screw
27		Inspect dot snap to ensure it functions	D - Dot snap doesn't function

Section IV. MAINTENANCE INSTRUCTIONS

2-9.A. M6 BAYONET-KNIFE AND M7 BAYONET-KNIFE - MAINTENANCE INSTRUCTIONS.

THIS TASK COVERS:

- |                      |                    |
|----------------------|--------------------|
| a. Disassembly       | c. Clean/Lubricate |
| b. Inspection/repair | d. Reassembly      |

INITIAL SETUP

Tools and Special Tools

Small arms repairman tool kit (app B)

References

- Appendix B
- Appendix C
- Appendix D

Materials/Parts

- Abrasive cloth (item 4, app D)
- CLP (item 3, app D)
- Dry cleaning solvent (item 5, app D)
- LAW (item 9, app D)
- LSA (item 10, app D)
- Rubber gloves (item 7, app D)
- Solid film lubricant (item 8, app D)
- Wash pan (item 11, app D)
- Wiping rag (item 12, app D)

NOTE

The following procedures apply to both tile M8 and M7 Bayonet-knives, except as noted.

2-9.A. M6 BAYONET-KNIFE AND M7 BAYONET-KNIFE--MAINTENANCE INSTRUCTIONS.

WARNING

The bayonet blade is sharp. Handle with care. Keep tip of blade pointed away from body at all times.

DISASSEMBLY

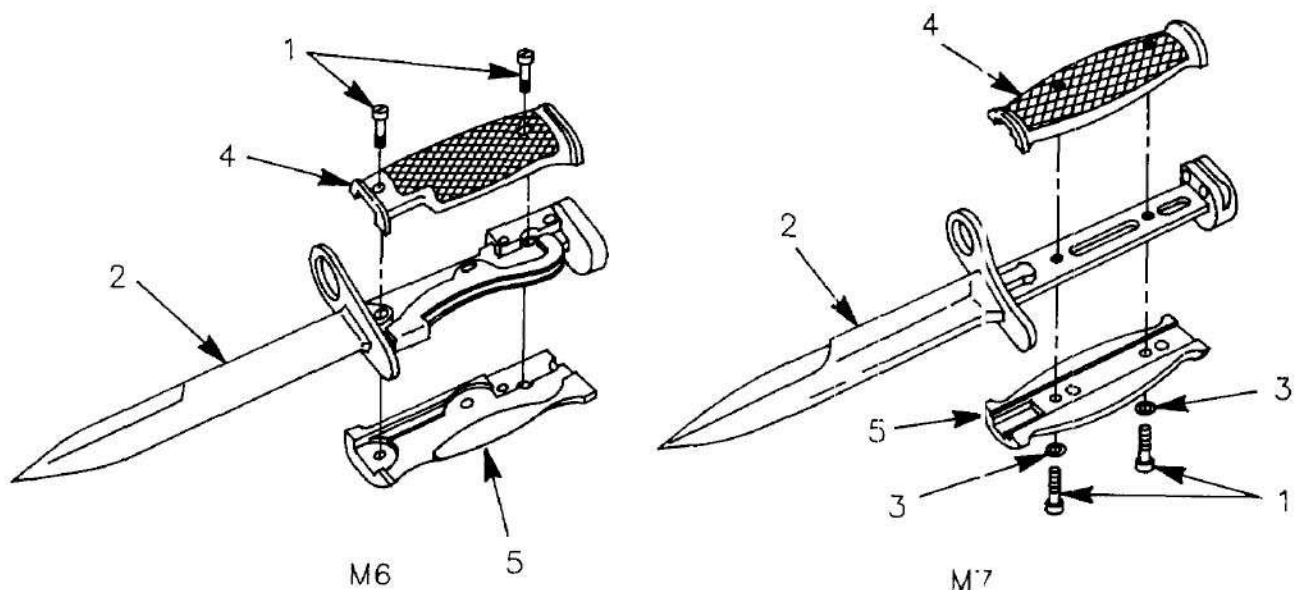

1. Remove two grip screws (1) from blade assembly (2).

NOTE

On the M7 Bayonet-knife there are two lockwashers (3) to remove after the two grip screws.

2. Remove LH grip (4) and RH grip (5).

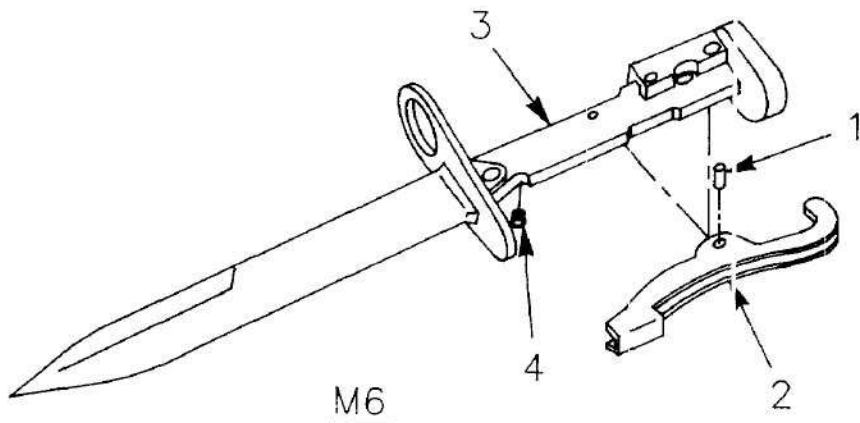

3. For M6 bayonet only, remove spring pin (1) from lock-release lever (2) and blade assembly (3).

## 2-9.A. M6 BAYONET-KNIFE AND M7 BAYONET-KNIFE - MAINTENANCE INSTRUCTIONS (Cont).

## DISASSEMBLY (Cont)

## WARNING

To avoid injury to your eyes, be careful when removing and installing spring-loaded parts.

4. For M6 bayonet only, remove lock-release lever (2) and compression helical spring (4).

## INSPECTION/REPAIR

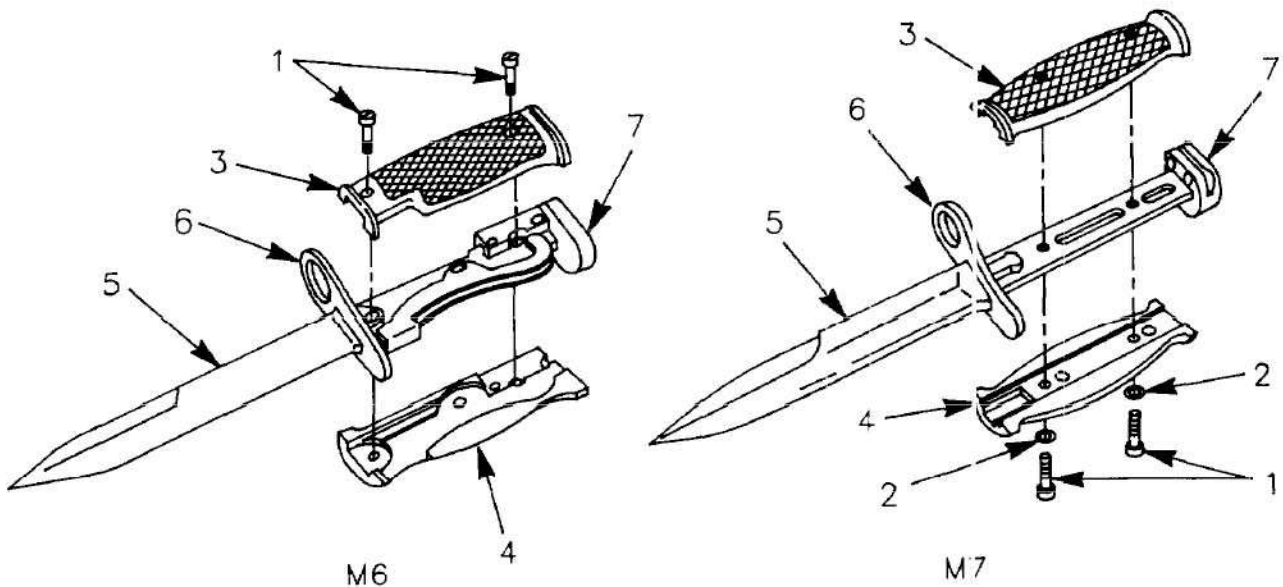

1. Inspect grip screws (1) for stripped or damaged threads. Check grip screw head for burrs, remove if present. Replace if necessary.

2. Inspect lockwashers (2) for damage (i.e., broken, has taken a set) on the M7 Bayonet-knife. Replace if necessary.

3. Inspect LH grip (3) and RH grip (4) for cracks and stripped threads. Hair-line cracks are acceptable. Cracks up to 1/4 in. (0.64 cm) in length are acceptable. If cracks are beyond 1/4 in. (0.64 cm), replace. Chips up to 1/8 in. (0.32 cm) are acceptable; beyond 1/8 in. (0.32 cm), replace the grip.

4. Inspect blade assembly (5) for cracks, nicks, or blunted points. Bayonets with cracked blades must be replaced. Blunted points and small nicks may be repaired by stoning. If the blade assembly has deep nicks requiring grinding (nicks that can't be removed by stoning), evacuate the bayonet to D.S. Maintenance. Nicks up to 3/16-inch (0.48cm) can be removed by grinding,.

2-9.A. M6 BAYONET-KNIFE AND M7 BAYONET-KNIFE--MAINTENANCE INSTRLUCTIONS (Cont).

INSPECTION/REPAIR (Cont)

NOTE

Length of the M6 and M7 blade measured from guard must not be less than 6-1/8 in. (15.56 cm) after repointing.

5. Inspect/check guard area (6) of blade assembly and plate area (7) of blade assembly for looseness. If loose, evacuate bayonet to direct support maintenance.

6. Inspect for worn or shiny areas on blade assembly, re-establish finish as follows step 11.

7. If point is broken, evacuate to D. S. Maintenance.

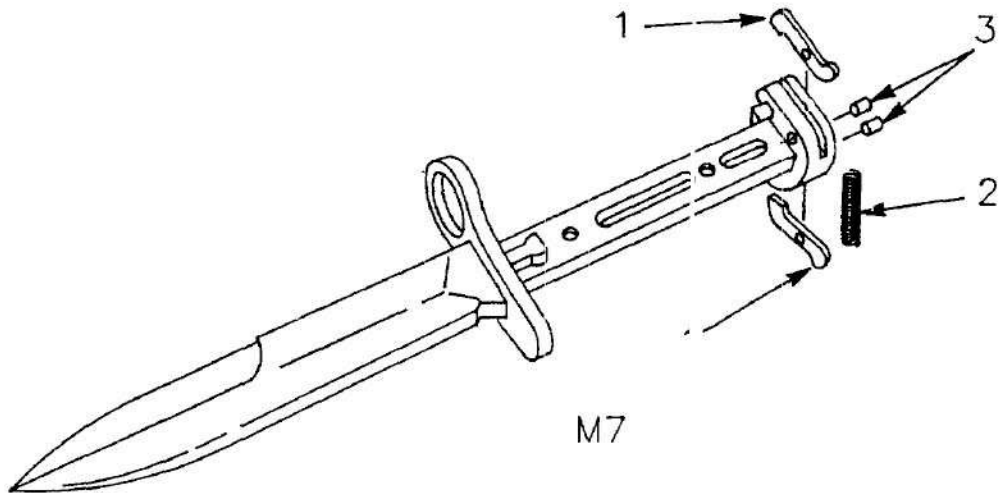
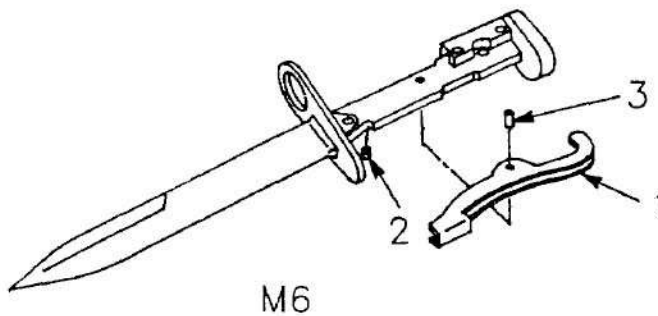

8. For M6 bayonet only, inspect lock-release lever (1) for bends and wear. Lock-release lever may be repaired by straightening.

9. Inspect compression helical spring (2) for kinks, set, and breaks. If any of these situations are found, replace.

## 2-9.A. M6 BAYONET-KNIFE AND M7 BAYONET-KNIFE--MAINTENANCE INSTRUCTIONS (Cont).

## INSPECTION/REPAIR (Cont)

10. Inspect spring pin (3) for burrs and wear. If worn or burred spring pin interferes with proper use, replace.

## WARNING

Dry cleaning solvent (A-A-711) is flammable and should not be used near an open flame or in a smoking area. Use only in well-ventilated areas. This solvent evaporates quickly and has a drying effect on the skin. When used without gloves, it may irritate, inflame or cause cracks in the skin.

11. Re-establish finish as required.

a. Remove all lubricant from surfaces to be treated with dry cleaning solvent (item 5, app D). Wear rubber gloves (item 7, app D) and use wash pan (item 11, app D) and brush (item 2, app D) to apply dry cleaning solvent.

## CAUTION

Do not use wire brush to roughen surface.

b. Roughen surface using abrasive cloth (item 4, app D).

c. Be sure surface to be treated is thoroughly cleaned and dried prior to application of solid film lubricant.

## WARNING

When using solid film lubricant, be sure area is well ventilated.

## NOTE

If solid film lubricant comes in contact with the functional surfaces of the lock-release lever, remove lubricant immediately by washing with dry cleaning solvent (item 5, app D).

d. Apply solid film lubricant (item 8, app D) to shiny surfaces. Allow to dry 16 to 24 hours before handling.

12. Repair is by replacement of authorized parts (app C) as required.

## CLEAN/LUBRICATE

## NOTE

For use of lubricant, refer to paragraph 2-4.

Wipe bayonets with wiping rag (item 12, app D) and apply a light coat of lubricant.

2-9.A. M6 BAYONET-KNIFE AND M7 BAYONET-KNIFE--MAINTENANCE INSTRUCTIONS (Cont).

REASSEMBLY

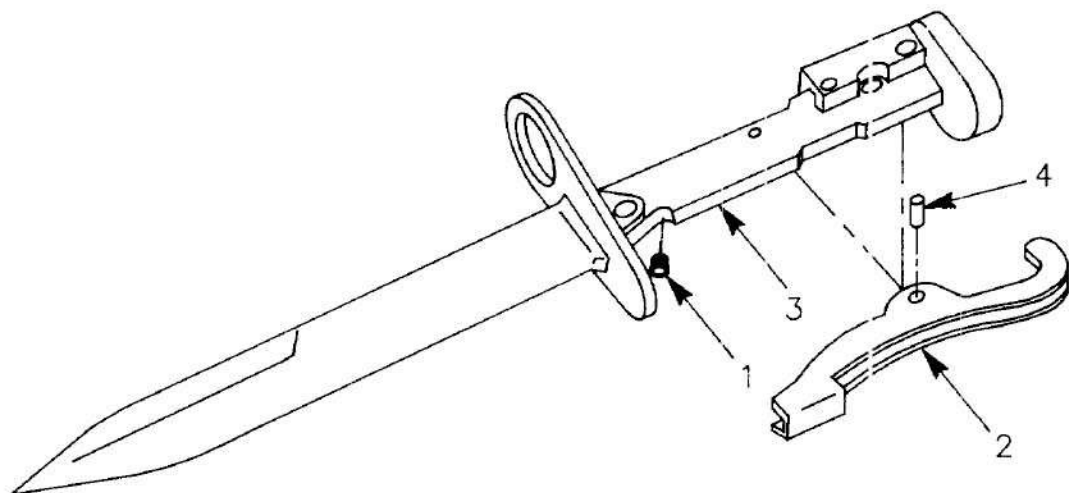

M6

1. For M6 bayonet only, if required, install compression helical spring (1) and lock-release lever (2) on blade assembly (3).
2. Drive in spring pin (4).

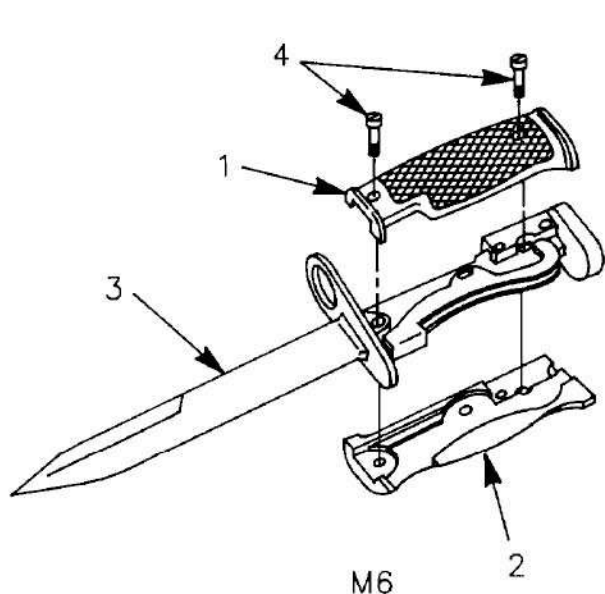

M6

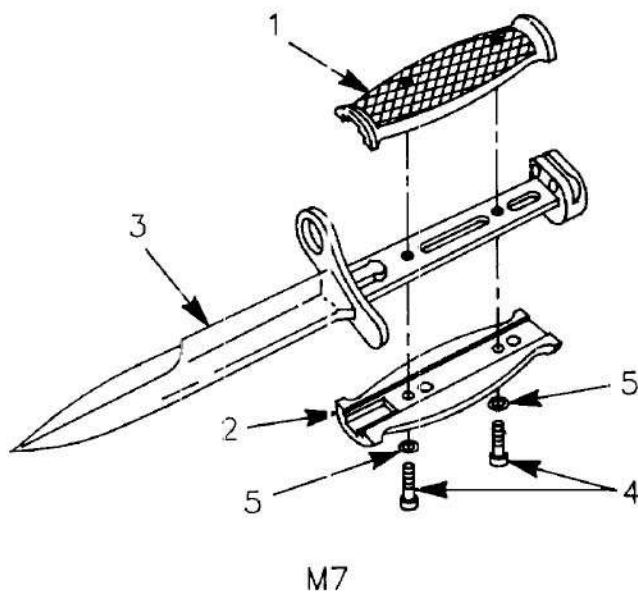

M7

3. Position LH grip (1) and RH grip (2) on blade assembly (3).

NOTE

On the M7 Bayonet-knife there are two lockwashers (5) to install before the two grip screws.

4. Install two grip screws (4) as shown above.

## 2-9.B. M7 BLADE ASSEMBLY-MAINTENANCE INSTRUCTIONS.

## THIS TASK COVERS:

- a. Disassembly    b. Inspection/repair    c. Clean/lubricate    d. Reassembly

## INITIAL SETUP

## Tools and Special Tools

Small arms repairman tool kit (app B)

## Materials/Parts

Brush (item 2, app D)

CLP (item 3, app D)

LSA (item 10, app D)

Solid Film Lubricant (item 8, app D)

Wiping rag (item 12, app D)

## References

Appendix B

Appendix C

Appendix D

The lock-release levers and compression helical spring are common to the M7 and M9 bayonet-knives.

## WARNING

Keep tip of blade assembly pointed away from body at all times.

To avoid injury to your eyes, be careful when removing and installing spring-loaded parts.

## NOTE

Disassemble only if required for repair or cleaning.

## DISASSEMBLY

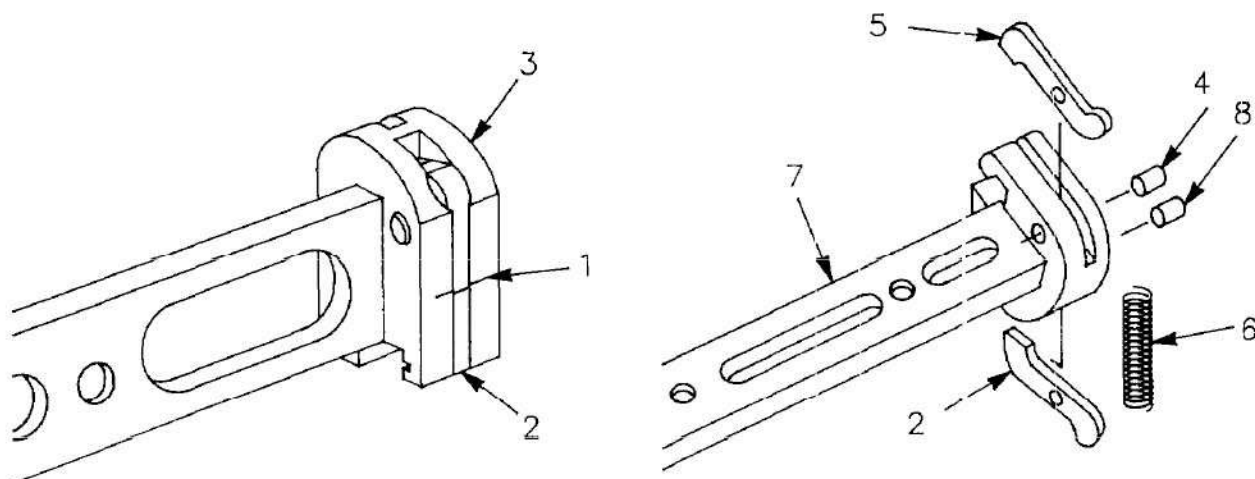

1. If a line is not present, scribe a line (1) on RH lock-release lever (2) and plate (3) before disassembly to assist in identification when reassembling.

2-9.B. M7 BLADE ASSEMBLY-MAINTENANCE INSTRUCTIONS (Cont).

DISASSEMBLY (Cont)

2. Remove spring pin (4), LH lock-release lever (5), and compression helical spring (6) from bayonet-knife (7).

3. Remove spring pin (8) and RH lock-release lever (2).

INSPECTION/REPAIR

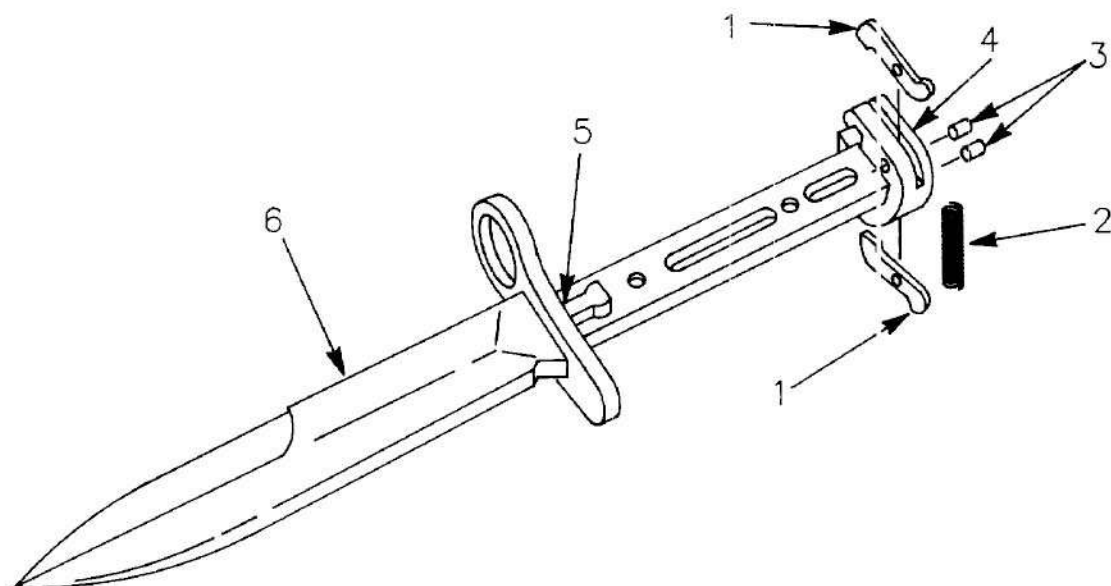

1. Inspect lock-release levers (1) for wear and bends. If positive retention is questionable, replace the lock-release levers.
2. Inspect compression helical spring (2) for kinks, sets, and breaks. Replace if damaged.
3. Inspect spring pins (3) for burrs and wear. Replace if worn or damaged.
4. Inspect plate area (4) of blade for looseness. If loose, evacuate to D.S. Maintenance.
5. Inspect guard (5) and link area of blade for looseness. If loose, evacuate to D.S. Maintenance.

## 2-9.B. M7 BLADE ASSEMBLY-MAINTENANCE INSTRUCTIONS (Cont).

## INSPECTION/REPAIR (Cont)

6. Inspect for worn or shiny areas on blade assembly (6), re-establish finish as follows.

## WARNING

Dry cleaning solvent (A-A-711) is flammable and should not be used near an open flame or in a smoking area. Use only in well-ventilated areas.

This solvent evaporates quickly and has a drying effect on the skin. When used without gloves it may irritate, inflame or cause cracks in the skin.

a. Remove all lubricant from surfaces to be treated with dry cleaning solvent (item 5, app D). Wear rubber gloves (item 7, app D) and use a wash pan (item 11, app D) and brush (item 2, app D) to apply dry cleaning solvent.

## CAUTION

Do not use wire brush to roughen surface.

b. Roughen surface using abrasive cloth (item 4, app D).

c. Be sure surface to be treated is thoroughly cleaned and dried prior to application of solid film lubricant.

## WARNING

When using solid film lubricant, be sure area is well ventilated.

## NOTE

If solid film lubricant comes in contact with the functional surfaces of the lock-release lever, remove lubricant immediately by washing with dry cleaning solvent (item 5, app D).

d. Apply solid film lubricant (item 8, app D) to shiny surfaces. Allow to dry 16 to 24 hours before handling.

7. Repair is by replacement of authorized parts (app C) as required.

## CLEAN/LUBRICATE

## NOTE

For use of lubricant refer to paragraph 2-4.

Wipe all parts with wiping rag (item 12, app D) and apply a light coat of lubricant.

## 2-9.B. M7 BLADE ASSEMBLY--MAINTENANCE INSTRUCTIONS (Cont).

## REASSEMBLY

## NOTE

Proper positioning of lock-release levers is required for bayonet to mount on rifle. To properly position lock-release levers, flat end (1) that grasps rifle faces forward while scribe (2) on right lock-release lever faces right and outward. If unscribed, both flat ends (1) that grasp the rifle face forward. Newer lock-release levers have an indentation (3) on the finger grip (the serrated end) which face rearward when properly positioned.

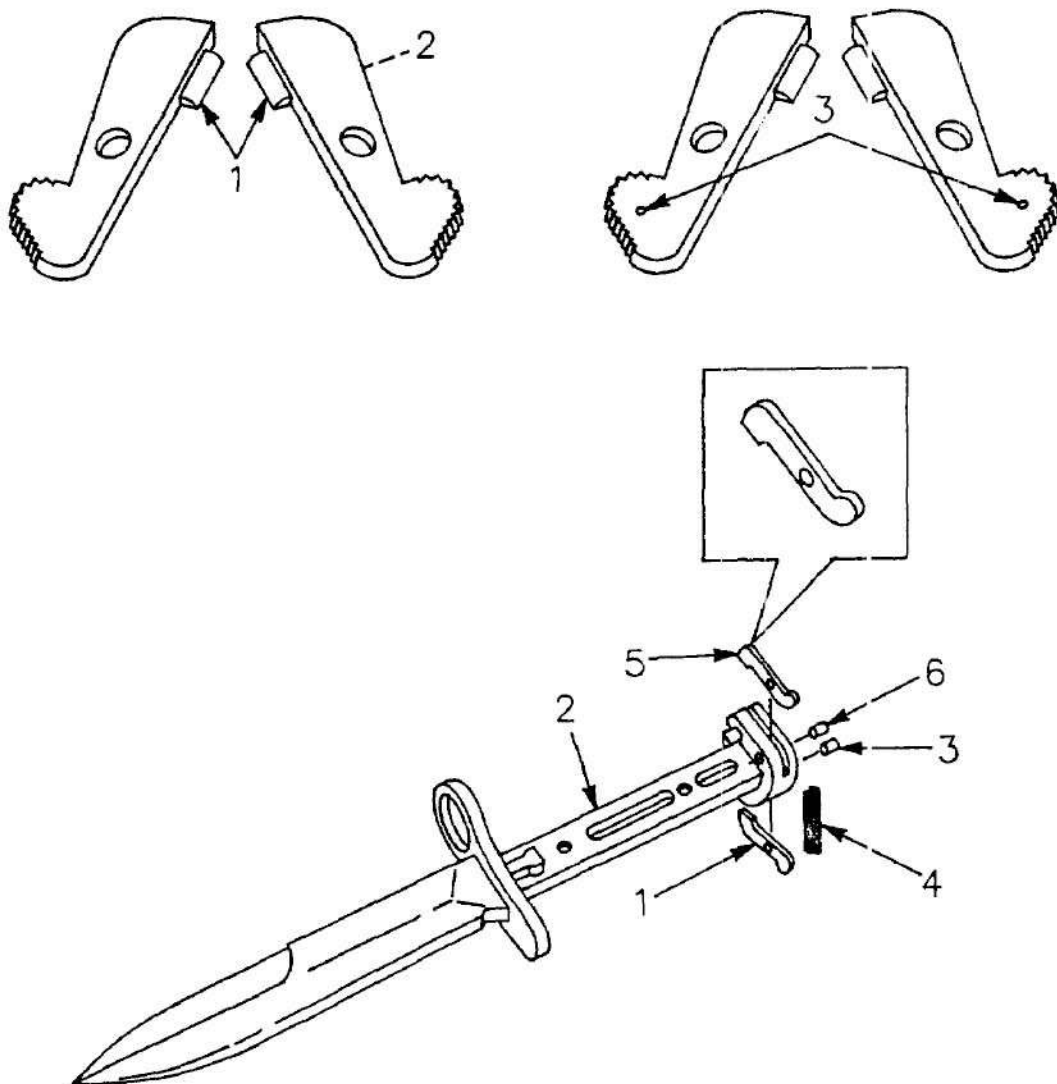

1. Position RH lock-release lever (1) on bayonet-knife (2) and install spring pin (3).

2. Install compression helical spring (4), LH lock-release lever (5) and spring pin (6).

## 2-10. M10 BAYONET-KNIFE SCABBARD--MAINTENANCE INSTRUCTIONS.

THIS TASK COVERS:

Inspection/repair

## INITIAL SETUP

## Materials/Parts

Abrasive cloth (item 4, app D)  
 CLP (item 3, app D)  
 Dry cleaning solvent (item 5, app D)  
 LAW (item 9, app D)  
 LSA (item 10, app D)  
 Olive drab enamel (item 6, app D)  
 Rubber gloves (item 7, app D)  
 Solid film lubricant (item 8, app D)  
 Wash pan (item 11, app D)  
 Wiping rag (item 12, app D)

## References

Appendix C  
 Appendix D

## INSPECTION/REPAIR

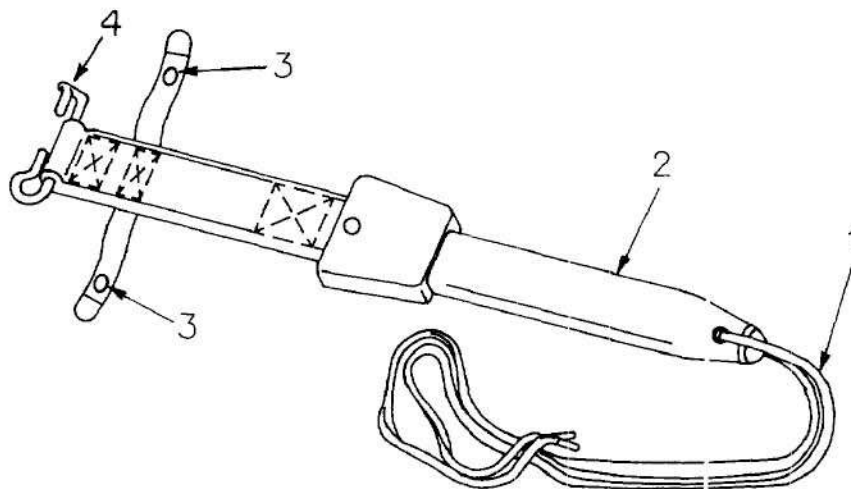

M10 BAYONET-KNIFE SCABBARD

1. Untie and remove scabbard restraining lace (1) from body (2).
2. Inspect scabbard restraining lace (1) for damage such as cuts or tears. Replace if unserviceable.
3. Inspect body (2) for chipped, deeply scratched, or heavily marred surfaces. Smooth using abrasive cloth (item 4, app D). Touch-up if needed with olive drab enamel (item 6, app D). Cracks 1/2 inch or less are not cause for repair. Cracks over 1/2 inch, replace the scabbard.
4. Inspect snaps (3) for proper functioning. Replace scabbard if defective.

2-10. MIO BAYONET-KNIFE SCABBARD - MAINTENANCE INSTRUCTIONS. (Cont)

INSPECTION/REPAIR (Cont)

5. Inspect metal parts (4) for worn or shiny areas. Worn or shiny areas will be repaired as follows:

WARNING

Dry cleaning solvent (A-A-711) is flammable and should not be used near an open flame or in a smoking area. Use only in well-ventilated areas. This solvent evaporates quickly and has a drying effect on the skin. When used without gloves it may irritate, inflame or cause cracks in the skin.

a. Remove all lubricant from surfaces to be treated with dry cleaning solvent (item 5, app D). Wear rubber gloves (item 7, app D) and use a wash pan (item 11, app D) and brush (item 2, app D) to apply dry cleaning solvent.

CAUTION

Do not use wire brush to roughen surface.

b. Roughen surface using abrasive cloth (item 4, app D).

c. Be sure surface to be treated is thoroughly cleaned and dried prior to application of solid film lubricant.

WARNING

When using solid film lubricant, be sure area is well-ventilated.

d. Apply solid film lubricant (item 8, app D) to shiny or worn surface. Allow to dry 16 to 24 hours before handling.

6. Repair is by replacement of authorized parts (app C) as required.

NOTE

For use of lubricant, refer to paragraph 2-4.

7. Wipe body with wiping rag (item 12, app D) and apply a light coat of lubricant.

8. Secure scabbard restraining lace (1) on body (2).

## 2-11.A. M9 MULTIPURPOSE BAYONET SYSTEM--MAINTENANCE INSTRUCTIONS.

## BAYONET-KNIFE

## THIS TASK COVERS:

- |                      |                    |
|----------------------|--------------------|
| a. Disassembly       | c. Clean/lubricate |
| b. Inspection/repair | d. Reassembly      |

## INITIAL SETUP

## Tools and Special Tools

Small arms repairman tool kit (app B)

## References

Appendix B

Appendix C

Appendix D

## Materials/Parts

Abrasive cloth (item 4, app D)

CLP (item 3, app D)

Dry cleaning solvent (item 5, app D)

LAW (item 9, app D)

LSA (item 10, app D)

Rubber gloves (item 7, app D)

Solid film lubricant (item 8, app D)

Wash pan (item 11, app D)

Wiping rag (item 12, app D)

## WARNING

The bayonet blades are sharp. Handle with care.

Keep tip of blade pointed away from body at all times.

## DISASSEMBLY

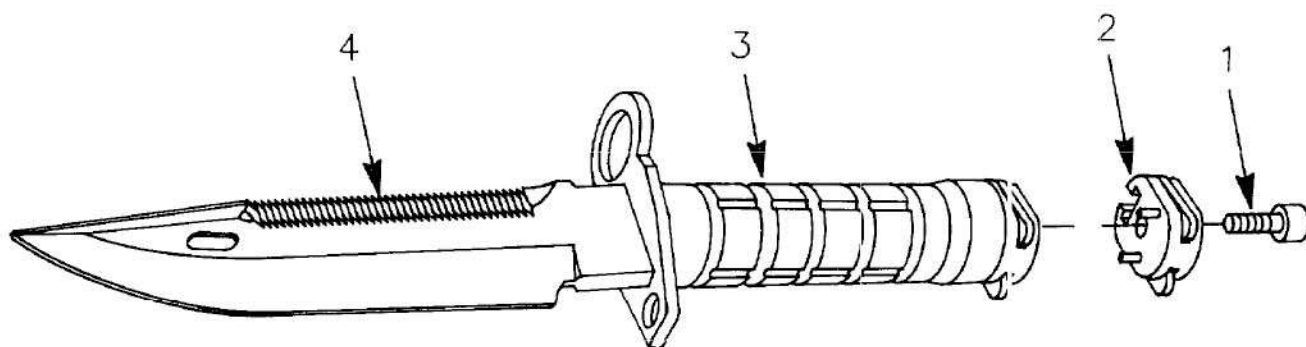

1. Unscrew and remove cap screw (1).
2. Remove latch assembly (2).
3. Remove handle (3) from blade assembly (4).

2-11.A. M9 MULTIPURPOSE BAYONET SYSTEM--MAINTENANCE INSTRUCTIONS (Cont).

BAYONET-KNIFE (Cont)

INSPECTION/REPAIR

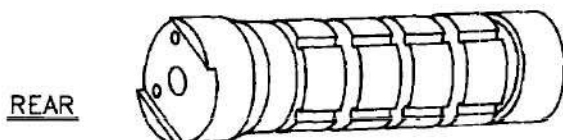
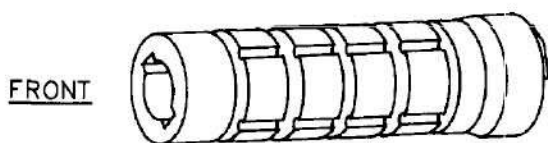
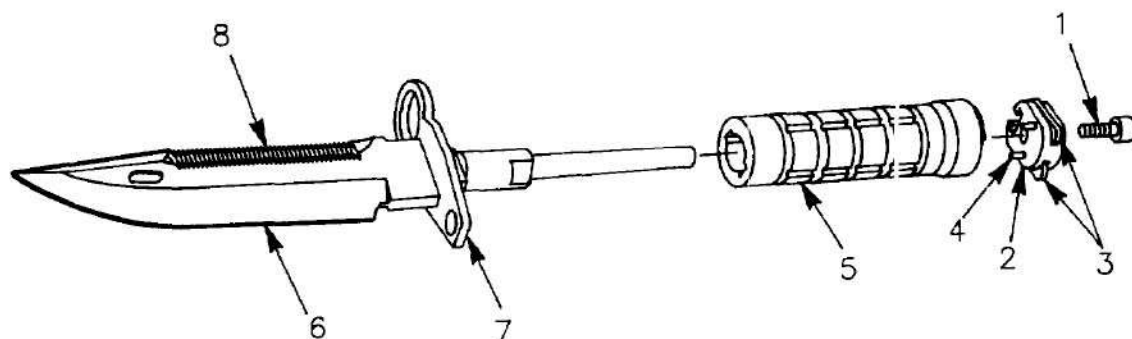

1. Inspect cap screw (1) for stripped threads or damage. Replace if necessary.
2. Inspect the latch assembly (2) as follows:
  - a. Inspect spring of the right hand and left hand lock-release levers (3) for proper functioning by depressing the right and left Lock-release levers. Replace spring if necessary. (Refer to 2-11.B)
  - b. Inspect spring pins (4) for damage or looseness. If damaged or loose, replace. (Refer to 2-11.B)
  - c. Inspect for rust/corrosion. Clean and lubricate. If unable to remove rust/corrosion, replace component. (Refer to 2-11.B)

## 2-11.A. M9 MULTIPURPOSE BAYONET SYSTEM--MAINTENANCE INSTRUCTIONS (Cont).

## BAYONET-KNIFE (Cont)

## INSPECTION/REPAIR (Cont)

3. Inspect handle (5) for cracks or chips/nicks.

a. Cracks up to 1/2 inch in length are acceptable. Replace if cracks are more than 1/2 inch in length.

b. Chips/nicks up to 1/4 inch in diameter are acceptable. Replace if chips/nicks are more than 1/4 inch in diameter.

c. Inspect front of handle for damage to alignment slots, If damage allows rotation of handle when installed, replace.

d. Inspect rear of handle alignment holes. If damage allows latch assembly to rotate from correct alignment with blade, replace.

## NOTE

Length of blade measured from handguard must not be less than 6 3/4 inches after repointing.

4. Inspect blade (6) for cracks, nicks or blunted point. Bayonets with cracked blades must be replaced. Blunted points and small nicks may be repaired by stoning. If the blade assembly has deep nicks requiring grinding (nicks that can't be removed by stoning), evacuate the bayonet to direct support maintenance.

5. Inspect handguard (7) for deformity. If deformed beyond use, replace bayonet.

6. Inspect saw teeth (8) for broken or dulled teeth. If 1/4 of the saw teeth are broken or worn, replace bayonet.

7. Re-establish finish as follows:

## WARNING

Dry cleaning solvent (A-A-711) is flammable and should not be used near an open flame or in a smoking area. Use only in well-ventilated areas. This solvent evaporates quickly and has a drying effect on the skin. When used without gloves, it may irritate, inflame or cause cracks in the skin.

a. Remove all lubricant from surfaces to be treated with dry cleaning solvent (item 5, app D). Wear rubber gloves (item 7, app D) and use wash pan (item 11, app D) and brush (item 2, app D) to apply dry cleaning solvent.

## CAUTION

Do not use wire brush to roughen surface.

b. Roughen surface using abrasive cloth (item 4, app D).

2-11.A. M9 MULTIPURPOSE BAYONET SYSTEM--MAINTENANCE INSTRUCTIONS (Cont).

BAYONET-KNIFE (Cont)

INSPECTION/REPAIR (cont)

c. Be sure surface to be treated is thoroughly cleaned and dried prior to application of solid film lubricant.

WARNING

When using solid film lubricant, be sure area is well ventilated.

NOTE

If solid film lubricant comes in contact with the functional surfaces of the lock-release lever, remove lubricant immediately by washing with dry cleaning solvent (item 5, app D).

d. Apply solid film lubricant (item 8, app D) to shiny surfaces. Allow to dry 16 to 24 hours before handling.

WARNING

To avoid injury while tightening tang, clamp blade in a padded jaw vice.

CAUTION

Blade is brittle. Do not over tighten or apply sideways pressure that may break blade.

NOTE

Use hand pressure only when inspecting tang for looseness. Use no tools.

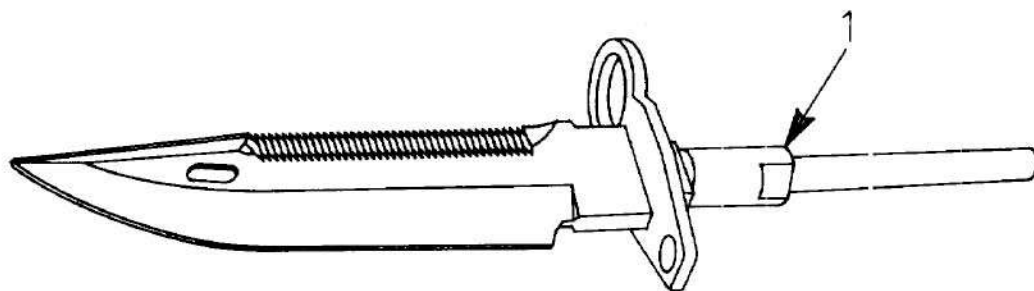

## 2-11.A. M9 MULTIPURPOSE BAYONET SYSTEM--MAINTENANCE INSTRUCTIONS (Cont).

## BAYONET-KNIFE (Cont)

## INSPECTION/REPAIR (Cont)

8. Inspect tang (1). If loose, tighten securely.
9. Repair is by replacement of authorized parts (app C) as required.

## CLEAN/LUBRICATE

## NOTE

For use of lubricant, refer to paragraph 2-4.

Wipe bayonet with wiping rag (item 12, app D) and apply a light coat of CLP (item 3, app D), LSA (item 10, app D) or LAW (item 9, app D).

## REASSEMBLY

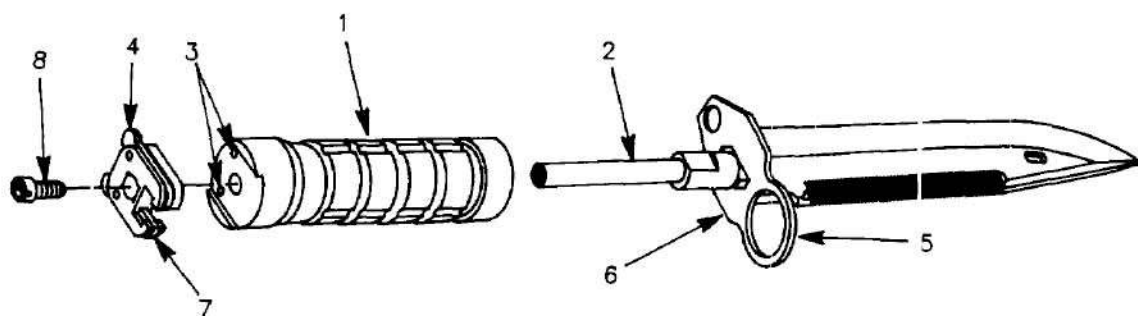

1. Install handle (1) on bayonet assembly (2) with small holes (3) for latch assembly (4) away from large hole (5) in hand guard (6).
2. Install latch assembly (4) with locking lug (7) lined with large hole in hand guard (6).
3. Install and tighten cap screw (8) until tight.

2-11.A. M9 MULTIPURPOSE BAYONET SYSTEM--MAINTENANCE INSTRUCTIONS (Cont).

BAYONET-KNIFE (Cont)

REASSEMBLY (Cont)

4. Further inspect latch assembly by insuring that the bayonet-knife assembly is retained securely on the bayonet lug of the rifle. The bayonet should mount and dismount without interference. If latch assembly doesn't function properly, repair the latch assembly. Refer to paragraph 2-11B. of this manual.

2-11.B. M9 MULTIPURPOSE BAYONET SYSTEM--MAINTENANCE INSTRUCTIONS (Cont).

LATCH ASSEMBLY

This task covers:

- a. Disassembly
- b. Inspection/repair
- c. Clean/lubricate
- d. Reassembly

INITIAL SETUP

Tools and Special tools  
 Small arms repairman tool kit (app B)

References  
 Appendix B  
 Appendix C  
 Appendix D

Materials/parts  
 Abrasive cloth (item 4, app D)  
 CLP (item 3, app D)  
 Dry cleaning solvent (item 5, app D)  
 LSA (item 10, app D)  
 Rubber gloves (item 7, app D)  
 Solid film lubricant (item 8, app D)  
 Wiping rag (item 12, app D)

Equipment Conditions  
 Latch assembly is removed from M9 Bayonet-Knife

DISASSEMBLY

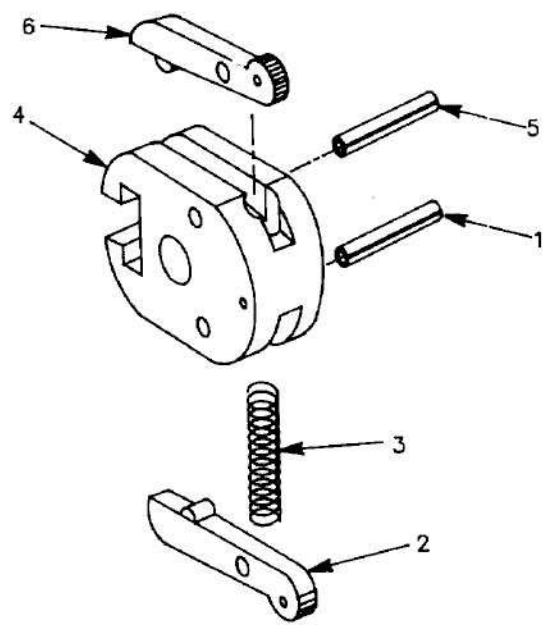

## 2-11.B. M9 MULTIPURPOSE BAYONET SYSTEM--MAINTENANCE INSTRUCTIONS (Cont).

## LATCH ASSEMBLY (Cont)

## DISASSEMBLY (Cont)

## WARNING

To avoid injury to your eyes, be careful when removing and installing spring-loaded parts.

1. Remove spring pin (1), LH lock-release lever (2), and compression helical spring (3) from latch plate (4).

2. Remove spring pin (5) and RH lock-release lever (6).

## INSPECTION/REPAIR

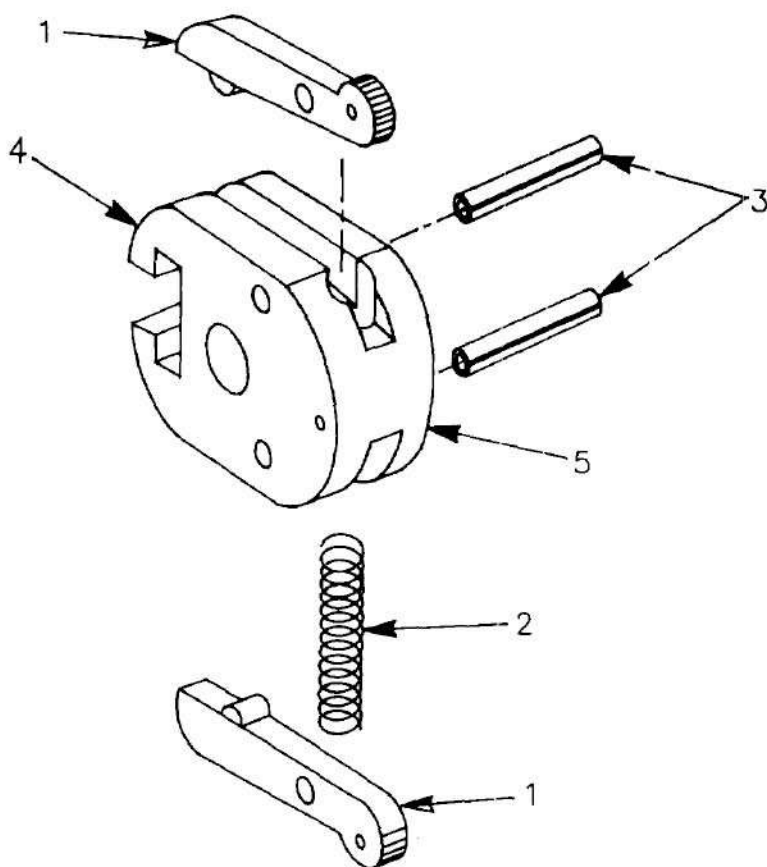

1. Inspect lock-release levers (1) for wear, bending and corrosion. If positive retention is questionable, replace the lock-release levers.

2. Inspect compression helical spring (2) for kinks, sets, breaks and corrosion.

3. Inspect spring pins (3) for burrs, wear and corrosion.

4. Inspect latch plate (4) for damage and corrosion.

5. For latch plate (5), reestablish finish as follows:

2-11.B. M9 MULTIPURPOSE BAYONET SYSTEM--MAINTENANCE INSTRUCTIONS (Cont).

LATCH ASSEMBLY (Cont)

6. If corrosion is found, clean and lubricate. If corrosion cannot be removed, replace component.

WARNING

Dry cleaning solvent (A-A-711) is flammable and should not be used near an open flame or in a smoking area. Use only in well-ventilated areas. This solvent evaporates quickly and has a drying effect on the skin. When used without gloves, it may irritate, inflame or cause cracks in the skin.

a. Using dry cleaning solvent (item 5, app D) remove all lubricant from surfaces to be treated. Wear rubber gloves (item 7, app D) to apply dry cleaning solvent.

CAUTION

Do not use wire brush to roughen surface.

b. Roughen surface using abrasive cloth (item 4, app D).

c. Be sure surface to be treated is thoroughly cleaned and dried prior to application of solid film lubricant.

WARNING

When using solid film lubricant, be sure area is well ventilated.

Dry cleaning solvent (A-A-711) is flammable and should not be used near an open flame or in a smoking area. Use only in well-ventilated areas. This solvent evaporates quickly and has a drying effect on the skin. When used without gloves, it may irritate, inflame or cause cracks in the skin.

NOTE

If solid film lubricant comes in contact with the functional surfaces of the lock-release lever, remove lubricant immediately by washing with dry cleaning solvent (item 5, app D).

d. Apply solid film lubricant (item 8, app D) to shiny surfaces. Allow to dry 16 to 24 hours before handling.

7. Repair is by replacement of authorized parts (app C) as required.

## 2-11.B. M9 MULTIPURPOSE BAYONET SYSTEM--MAINTENANCE INSTRUCTIONS (Cont).

## LATCH ASSEMBLY (Cont)

## CLEAN/LUBRICATE

## NOTE

For use of lubricant, refer to paragraph 2-4.

Wipe all parts with wiping rag (item 12, app D) and apply a light coat of lubricant.

## REASSEMBLY

## NOTE

Before installing, identify RH and LH lock-release levers. The indentation in each ear must face toward the soldier and be opposite the bayonet mounting slot. The RH lock-release lever is to the right when the bayonet-knife is pointing away and the saw teeth are on top of the blade.

## NOTE

Spring pins (1) must be installed flush or just below the back surface of the latch plate (2). The back of the latch plate is identified by an indentation (3).

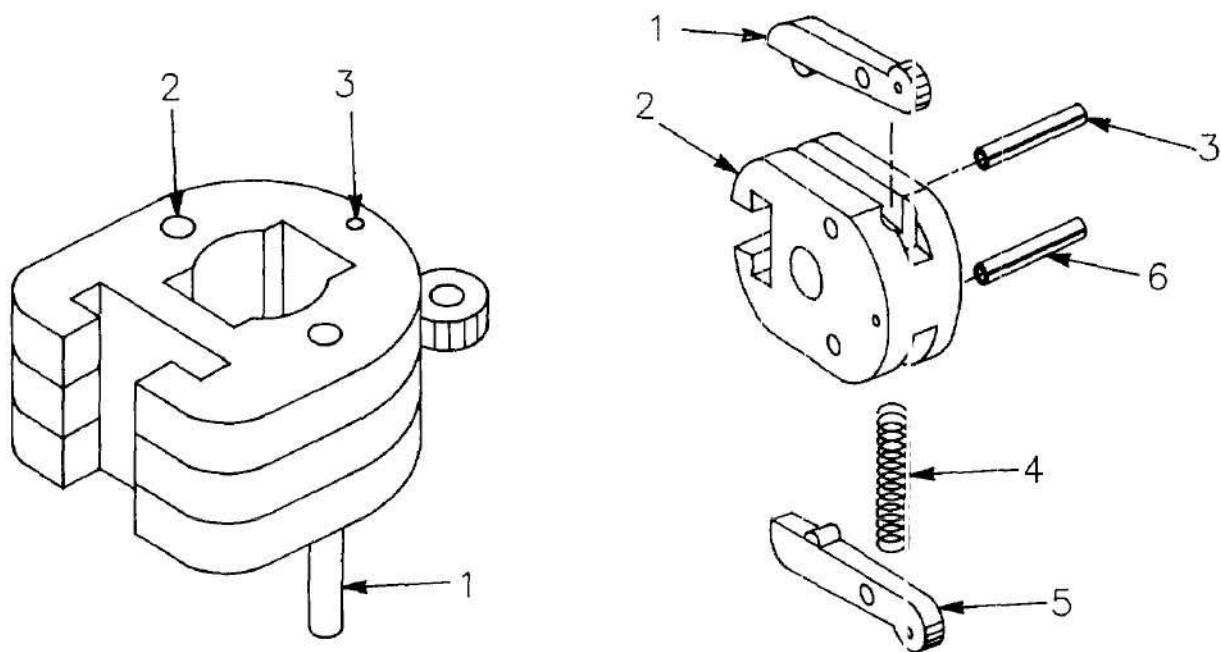

1. Position RH lock-release lever (1) on latch plate (2) and install spring pin (3).

2. Install compression helical spring (4), LH lock-release lever (5), and spring pin (6).

2-11.C. M9 MULTIPURPOSE BAYONET SYSTEM--MAINTENANCE INSTRUCTIONS (Cont).

SCABBARD

This task covers:

- |                      |                    |
|----------------------|--------------------|
| a. Disassembly       | c. Clean/lubricate |
| b. Inspection/repair | d. Reassembly      |

INITIAL SETUP

Tools and Special Tools

Small arms repairman tool kit (app B)

Materials/Parts

- Abrasive cloth (item 4, app D)
- CLP (item 3, app D)
- Dry cleaning solvent (item 5, app D)
- LSA (item 10, app D)
- Rubber gloves (item 7, app D)
- Solid film lubricant (item 8, app D)
- Wash pan (item 11, app D)
- Wiping rag (item 12, app D)

References

- Appendix B
- Appendix C
- Appendix D

Equipment Condition

Bayonet-knife is removed from scabbard

DISASSEMBLY

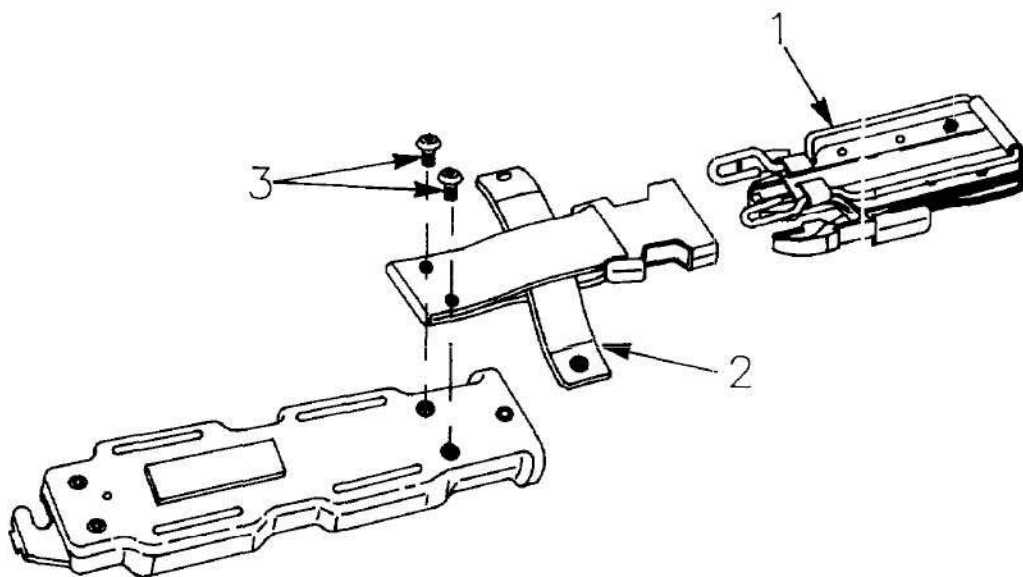

1. Remove attaching assembly load bearing end (1).
2. Separate attaching assembly scabbard end (2) by removing two socket head screws (3).

## 2-11.C. M9 MULTIPURPOSE BAYONET SYSTEM--MAINTENANCE INSTRUCTIONS (Cont).

## SCABBARD (Cont)

## INSPECTION/REPAIR

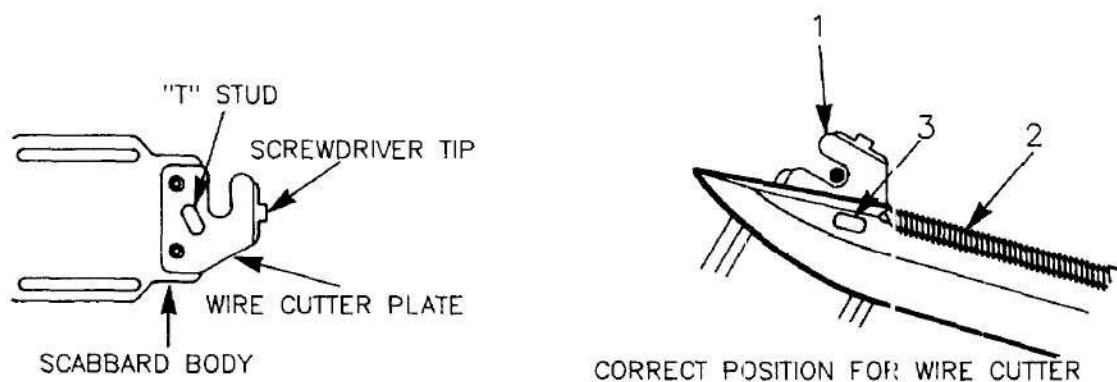

CORRECT POSITION FOR WIRE CUTTER

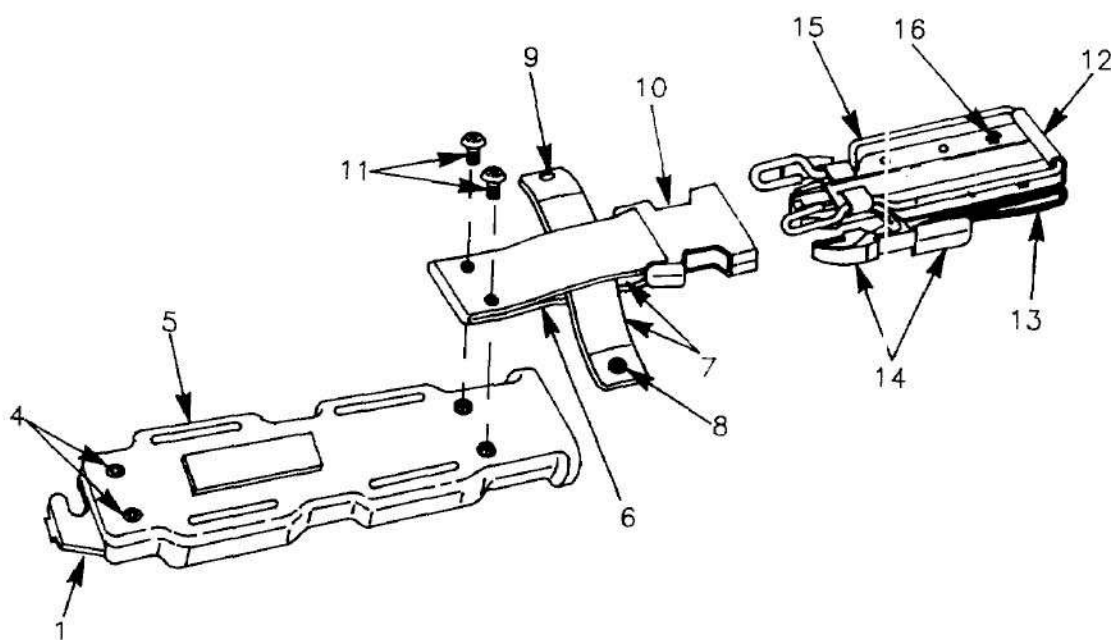

## WARNING

When using solid film lubricant, be sure area is well ventilated.

## NOTE

Cutter plate requires replacement only if it is cracked, broken, or won't cut wire.

Replacing screw driver tip is only necessary if it won't remove bayonet cap screw.

1. Inspect cutter assembly (1) for damage, shiny surface or corrosion. If damaged, evacuate to DS maintenance. If shiny surface, use solid film lubricant (item 8, app D) according to Paragraph 2-9.A. If corrosion, clean and lubricate with solid film lubricant.

2-11.C. M9 MULTIPURPOSE BAYONET SYSTEM--MAINTENANCE INSTRUCTIONS (Cont).

SCABBARD (Cont)

INSPECTION/REPAIR (Cont)

2. Inspect cutter assembly (1) by attaching blade (2) and checking stud (3) for proper functioning. If cutter assembly is worn and will not function properly, evacuate to DS Maintenance.
3. Inspect cutter assembly (1) for breaks and cracks. If cutter assembly is broken or cracked, evacuate to DS Maintenance.
4. Inspect socket head screw (4) for looseness and/or damage.
  - a. If loose, tighten with 1/8 inch socket head screw key.
  - b. If damaged, replace.
5. Inspect scabbard body assembly (5) for proper functioning. Replace if it will no longer retain the bayonet-knife.
6. Inspect attaching assembly scabbard end (6) for proper functioning.
  - a. Inspect webbing portion (7). Cuts up to 1/4 inch are acceptable. For cuts of more than 1/4 inch, replace attaching assembly scabbard end.
  - b. Inspect snap (8) and socket (9) for proper functioning. If defective, replace attaching assembly scabbard end.
  - c. Inspect plastic portion (10). If broken or defective and will not function correctly, replace attaching assembly scabbard end.
  - d. Inspect socket head screws (11), If defective or damaged, replace.
7. Inspect attaching assembly load bearing end (12) by checking for proper functioning.
  - a. Inspect webbing portion (13). Cuts up to 1/4 inch are acceptable. For cuts of more than 1/4 inch, replace attaching assembly load bearing end.
  - b. Inspect plastic portion (14). If broken or defective and will not function correctly, replace attaching assembly load bearing end.
  - c. Inspect metal portion (15). If metal portion is disfigured and interferes with proper functioning, replace attaching assembly load bearing end.
  - d. Inspect for loose or missing rivets (16). Tighten loose rivets by peening. If a rivet is missing or cannot be tightened, replace attaching assembly load bearing end.

## 2-11.C. M9 MULTIPURPOSE BAYONET SYSTEM--MAINTENANCE INSTRUCTIONS (Cont).

## SCABBARD (Cont)

## CLEAN/LUBRICATE

## NOTE

Refer to paragraph 2-4 for deciding which lubricant to use.

Wipe metal parts of scabbard with wiping rag (item 12, app D) and apply a light coat of lubricant.

## REASSEMBLY

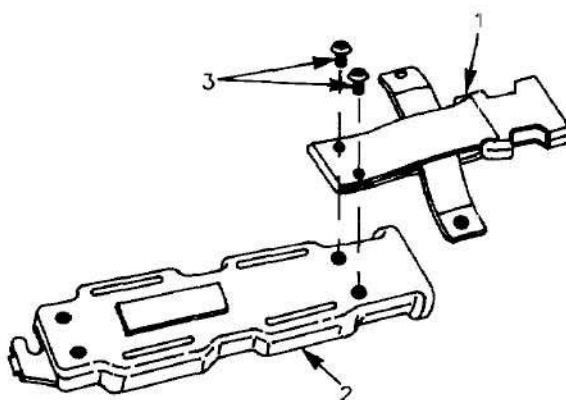

## CAUTION

Two different lengths of socket head screws are used on the scabbard. When replacing be sure to replace with the correct length socket head screw. Use the long screws to attach the cutter plate and the short screws to attach the attaching assembly, scabbard end.

1. Position attaching assembly scabbard end (1) on scabbard body assembly (2) so that fastener will close around M9 Bayonet-knife. Install two socket head screws (3).

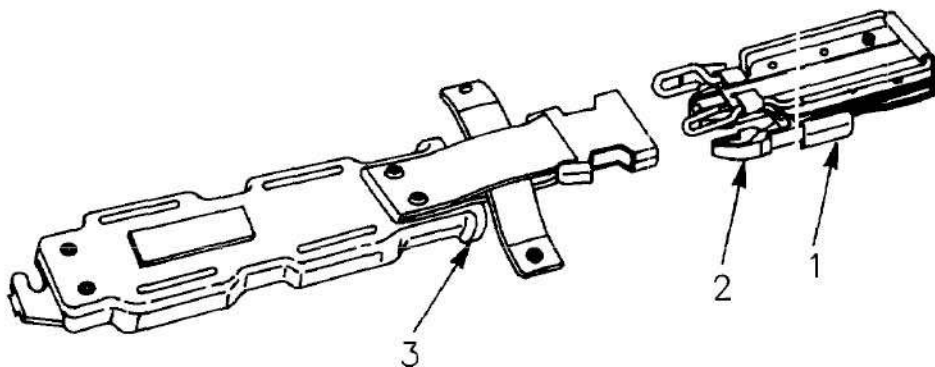

2. Install attaching assembly load bearing end (1) with plastic portion (2) towards M9 scabbard (3) as shown.

2-11.C. M9 MULTIPURPOSE BAYONET SYSTEM--MAINTENANCE, INSTRUCTIONS (Cont).

SCABBARD (Cont)

REASSEMBLY (Cont)

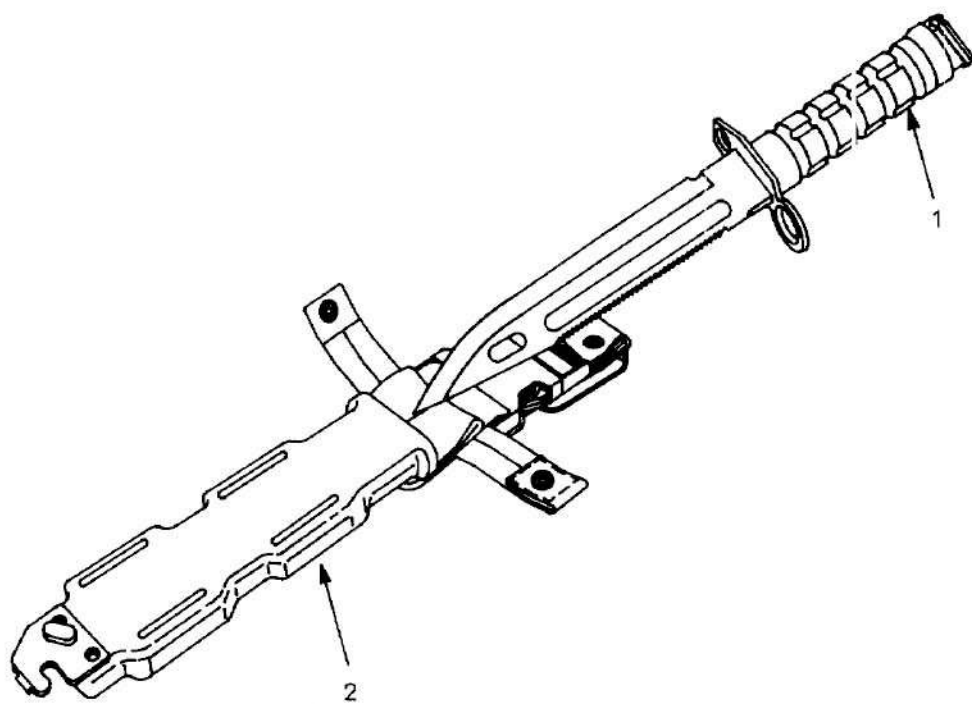

3. Insert bayonet (1) into the scabbard (2).

4. Fasten snap (3) of restraining strap (4).

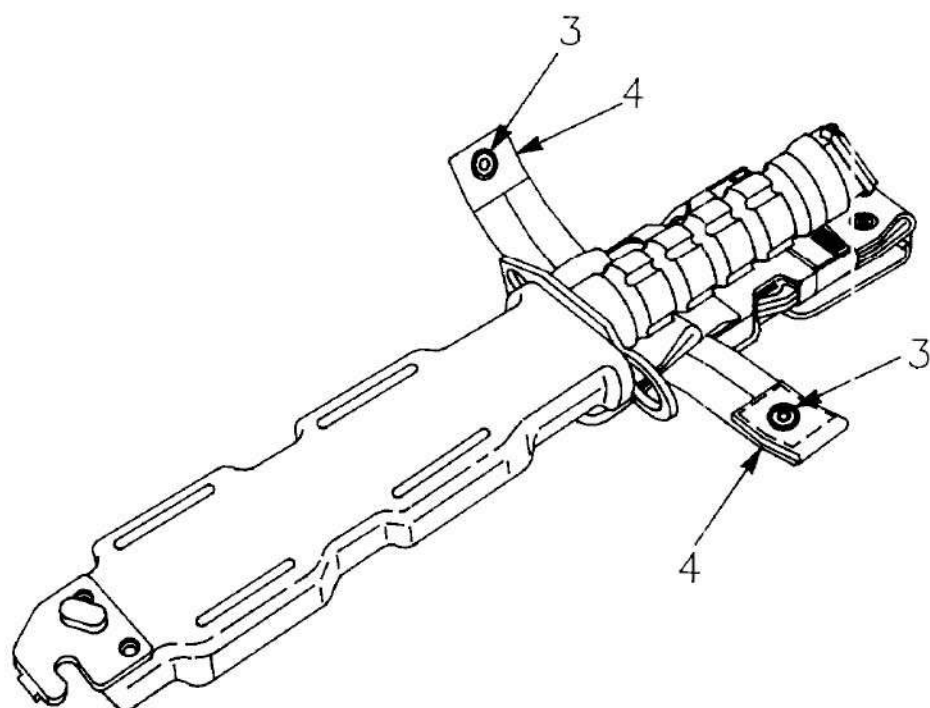

## 2-11.D. M9 MULTIPURPOSE BAYONET SYSTEM--MAINTENANCE INSTRUCTIONS (Cont).

## SCABBARD BODY ASSEMBLY

This task covers:

- |                |                    |
|----------------|--------------------|
| a. Inspection  | d. Clean/lubricate |
| b. Disassembly | e. Reassembly      |
| c. Repair      |                    |

## INITIAL SETUP

## Tools and Special Tools

Small arms repairman tool kit (app B)

## Materials/Parts

Brush (item 2, app D)  
 CLP (item 3, app D)  
 Dry cleaning solvent (item 5, app D)  
 LSA (item 10, app D)  
 Rubber gloves (item 7, app D)  
 Silicone adhesive (item 13, app D)  
 Wash pan (item 11, app D)  
 Wiping rag (item 12, app D)

## References

Appendix B  
 Appendix C  
 Appendix D

## Equipment Condition

bayonet-knife is removed from scabbard, scabbard body assembly is separately from attaching assembly scabbard end and attaching assembly load bearing end.

## INSPECTION

1. Visually inspect scabbard body assembly (1) for cracks. If cracked more than 1/2 inch, replace scabbard body assembly.
2. Inspect two socket head screws (2) for damage. If defective or damaged, replace.

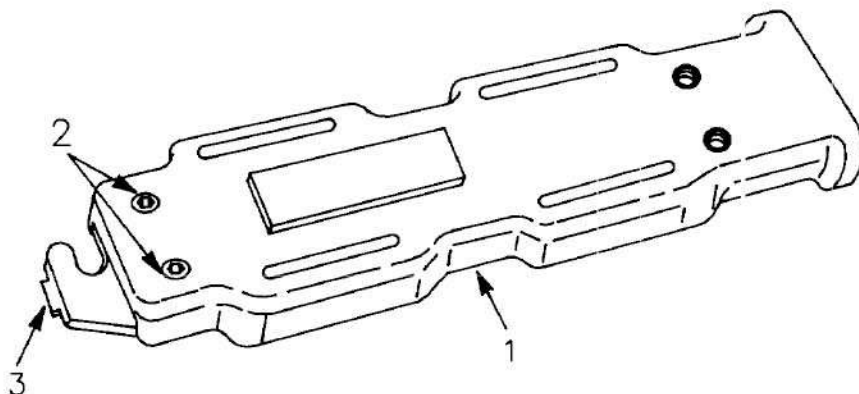

3. Inspect cutter assembly (3) for breaks and cracks. If cutter assembly is broken or cracked, evacuate to D.S. Maintenance.

2-11.D. M9 MULTIPURPOSE BAYONET SYSTEM--MAINTENANCE INSTRUCTIONS (Cont).

SCABBARD BODY ASSEMBLY (Cont)

INSPECTION (Cont)

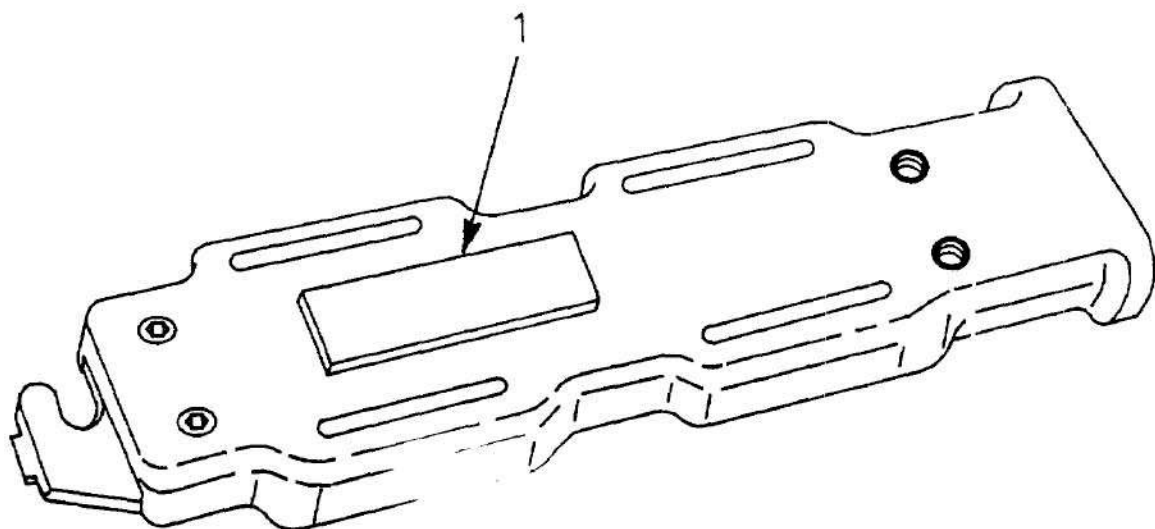

4. Inspect sharpening stone (1) for chips or damage. If damaged to the point that the stone cannot be utilized, replace the stone.

DISASSEMBLY

NOTE

Disassemble only if inspection indicates repair or cleaning is required.

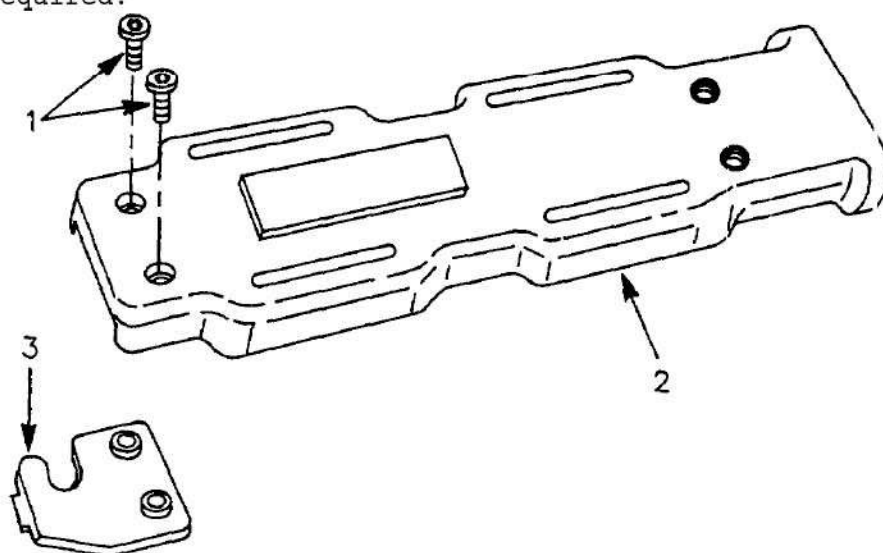

1. Remove two socket head screws (1) from scabbard body assembly (2).

2. Remove cutter assembly (3) from scabbard body assembly (2).

## 2-11.D. M9 MULTIPURPOSE BAYONET SYSTEM--MAINTENANCE INSTRUCTIONS (Cont).

## SCABBARD BODY ASSEMBLY (Cont)

## REPAIR

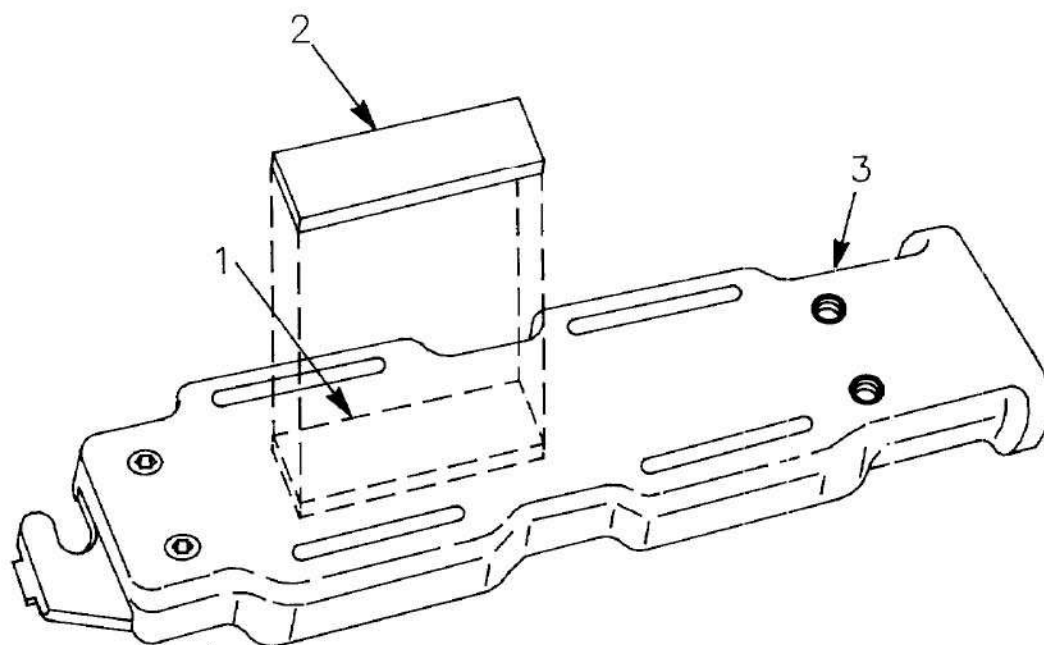

## WARNING

Dry cleaning solvent (A-A-711) is flammable and should not be used near an open flame or in a smoking area. Use only in well-ventilated areas. This solvent evaporates quickly and has a drying effect on the skin. When used without gloves, it may irritate, inflame or cause cracks in the skin.

## NOTE

Use of dry cleaning solvent is authorized on the scabbard body assembly only to remove old silicone adhesive.

1. If replacing the stone, chisel away remainder of sharpening stone (2) and adhesive. Take care not to damage the scabbard body (3).
2. Clean recess (1) for stone (2) with dry cleaning solvent (item 5, app D). Wear rubber gloves (item 7, app D) and use a wash pan (item 11, app D) and brush (item 2, app D) to apply dry cleaning solvent.
3. Allow recess (1) to dry before applying silicone adhesive (item 13, app D).
4. Apply silicone adhesive to recess (1) for stone (2).
5. Press replacement sharpening stone (2) in recess (1) and allow to dry.

2-11.D. M9 MULTIPURPOSE BAYONET SYSTEM--MAINTENANCE INSTRUCTIONS (Cont).

SCABBARD BODY ASSEMBLY (Cont)

CLEAN/LUBRICATE

1. Clean the scabbard body assembly with wiping rag (item 12, app D).

NOTE

Refer to paragraph 2-4 for deciding which lubricant to use.

Do not apply lubricant until after sharpening stone has been replaced, if it was removed.

2. Wipe metal parts of scabbard body assembly with wiping rag (item 12, app D) and apply a light coat of lubricant.

REASSEMBLY

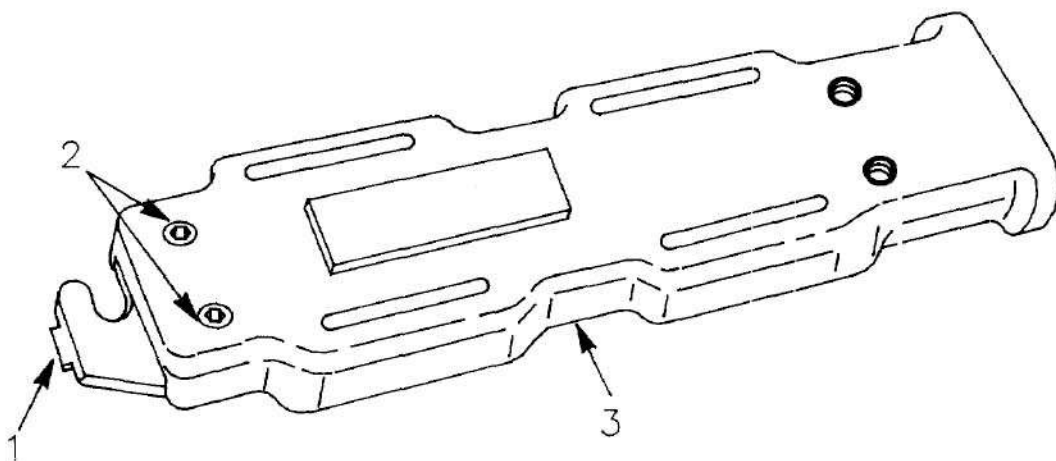

CAUTION

Two different lengths of socket head screws are used on the scabbard. When replacing be sure to replace with the correct length socket head screw. Use the long screws to attach the cutter plate and the short screws to attach the attaching assembly, scabbard end.

Attach cutter assembly (1) using two socket head screws (2) to scabbard body assembly (3).

## CHAPTER 3 DIRECT SUPPORT MAINTENANCE INSTRUCTIONS

## Section I MAINTENANCE PROCEDURES

## 3-1. M6 BAYONET-KNIFE - MAINTENANCE INSTRUCTIONS.

## THIS TASK COVERS:

- a. Inspection/repair

## INITIAL SETUP

## Tools and Special Tools

Small arms repairman tool kit (app B)  
 Small arms field maintenance tool kit  
 (app B)

## Materials/Parts

Brush (item 2, app D)  
 CLP (item 3, app D)  
 Dry cleaning solvent (item 5, app D)  
 LSA (item 10, app D)  
 Rubber gloves (item 7, app D)  
 Solid film lubricant (item 8, app D)  
 Wash pan (item 11, app D)  
 Wiping rag (item 12, app D)

## References

Appendix B  
 Appendix C  
 paragraph 2-9.A Disassembly,  
 Inspection/repair, Clean/  
 lubricate, and Reassembly of  
 M6 and M7 Bayonet-knives

## Equipment Conditions

paragraph 2-9.A. grips are  
 removed from M6 Bayonet-knife

## INSPECTION/REPAIR

1. Inspect blade for nicks on the cutting edge. Nicks up to 3/16-in. (0.48 cm) can be removed by grinding. Ground areas shall be blended with adjacent surfaces. Blades with deeper nicks should be replaced.
2. Repair broken point on blade by grinding and/or stoning. After repointing, the length of the blade (measured from the front face of the guard to the tip of the blade) must be at least 6-1/8 in. (15.56 cm). If less than 6 1/8 inch, replace bayonet.

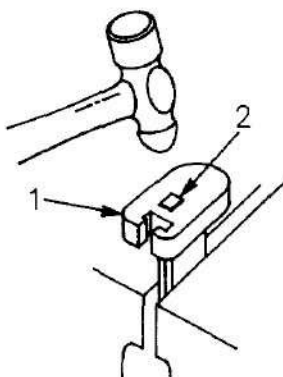

3. Check plate area (1) of blade assembly for looseness. If required, tighten by placing blade assembly in vise and stake or peen end of shank (2) over plate. Make sure that sufficient clearance remains to permit retention of the bayonet to the rifle.

3-1. M6 BAYONET-KNIFE--MAINTENANCE INSTRUCTIONS (Cont).

INSPECTION/REPAIR (Cont)

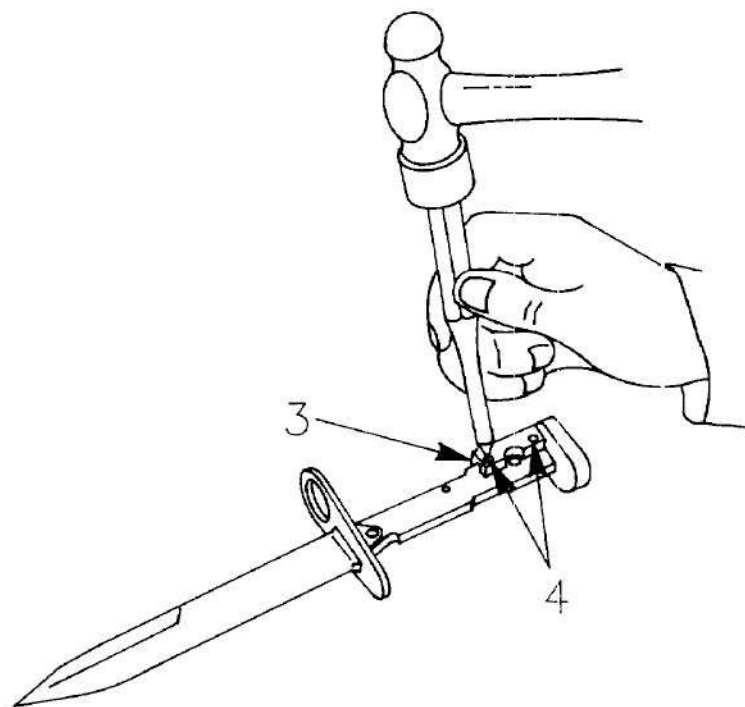

4. Check track area (3) of blade assembly for play. Remove any existing play by peening the two rivets (4) holding the tracks.

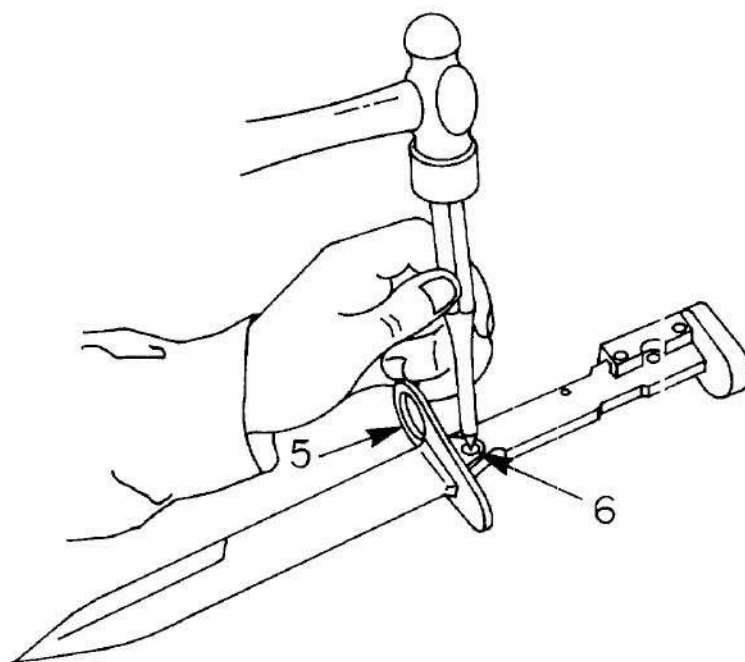

5. Check guard area (5) of blade assembly for play. Remove play by setting both sides of the sleeve (6) with a center punch and hammer.

## 3-1. M6 BAYONET-KNIFE--MAINTENANCE INSTRUCTIONS (Cont).

## INSPECTION/REPAIR (Cont)

6. Inspect for worn or shiny areas on blade assembly, re-establish finish as follows:

## WARNING

Dry cleaning solvent (A-A-711) is flammable and should not be used near an open flame or in a smoking area. Use only in well-ventilated areas. This solvent evaporates quickly and has a drying effect on the skin. When used without gloves, it may irritate, inflame or cause cracks in the skin.

a. Remove all lubricant from surfaces to be treated with dry cleaning solvent (item 5, app D). Wear rubber gloves (item 7, app D) and use a wash pan (item 11, app D) and brush (item 2, app D) to apply dry cleaning solvent.

## CAUTION

Do not use wire brush to roughen surface.

b. Roughen surface using abrasive cloth (item 4, app D)

c. Be sure surface to be treated is thoroughly cleaned and dried prior to application of solid film lubricant.

## WARNING

When using solid film lubricant, be sure area is well ventilated.

d. Apply solid film lubricant (item 8, app D) to shiny surfaces. Allow to dry 16 to 24 hours before handling.

## NOTE

If solid film lubricant comes in contact with the functional surfaces of the lock-release lever, remove lubricant immediately by washing with dry cleaning solvent (item 5, app D).

## 3-2. M7 BLADE ASSEMBLY-MAINTENANCE INSTRUCTIONS.

## THIS TASK COVERS:

## b. Inspection/repair

## INITIAL SETUP

## Tools and Special Tools

Small arms repairman tool set (app B)  
 Small arms field maintenance tool kit  
 (app B)

## Materials/Parts

Abrasive cloth (item 4, app D)  
 Brush (item 2, app D)  
 CLP (item 3, app D)  
 Dry cleaning solvent (item 5, app D)  
 LSA (item 10, app D)  
 Rubber gloves (item 7, app D)  
 Solid film lubricant (item 8, app D)  
 Wash pan (item 11, app D)  
 Wiping rag (item 12, app D)

## References

Appendix B  
 Appendix C  
 Appendix D  
 paragraph 2-9.A. Disassembly,  
 Inspection/repair, Clean/  
 lubricate and Reassembly of  
 M6 and M7 Bayonet-knives

## Equipment Conditions

paragraph 2-9.A. grips are  
 removed from M7 Bayonet-knife

## INSPECTION/REPAIR

1. Check blade for nicks on the cutting edge. Nicks up to 3/16-in. (0.48 cm) can be removed by grinding. Ground areas shall be blended with adjacent surfaces. Blades with deeper nicks should be replaced.
2. Repair broken point on blade by grinding and/or stoning. After pointing, the length of the blade (measured from the front face of the guard to the tip of the blade) must be at least 6-1/8 in. (15.56 cm). If less than 6 1/8 inch, replace bayonet.

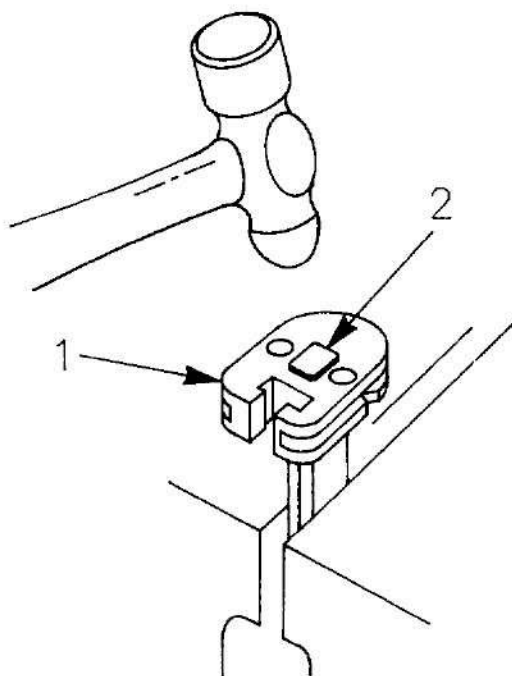

3. Inspect plate area (1) of blade for looseness. Tighten if necessary by placing blade in vise and stake or peen end of shank (2) over plate. Make sure that sufficient clearance remains to permit retention of the bayonet to the rifle.

## 3-2. M7 BLADE ASSEMBLY - MAINTENANCE INSTRUCTIONS. (Cont)

## INSPECTION/REPAIR (Cont)

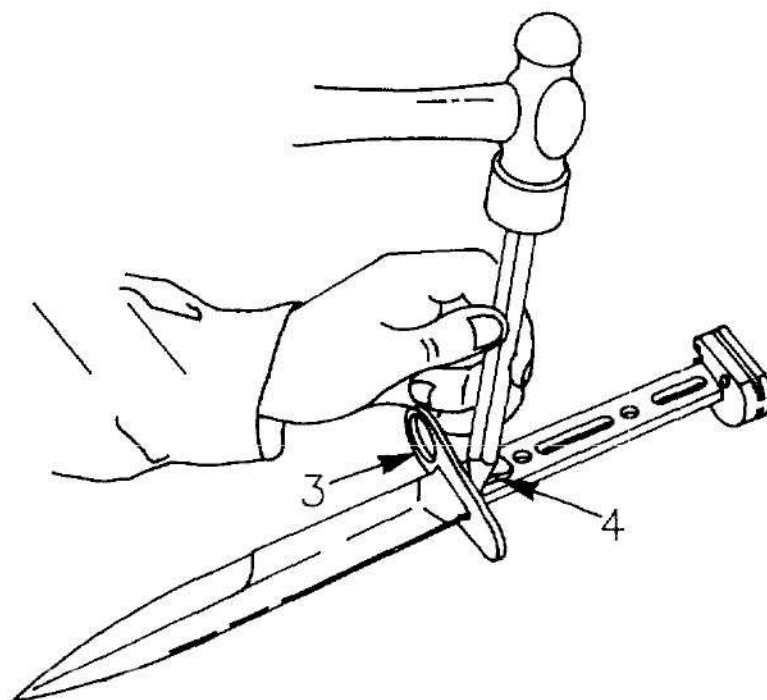

4. Inspect guard (3) and link area of blade for looseness. Tighten by swaging link (4) against the guard until the guard is firmly against the shoulders of the blade. Bright spots as a result of this operation are permissible.

5. Inspect for worn or shiny areas on blade assembly. re-establish finish as follows:

## WARNING

Dry cleaning solvent (A-A-711) is flammable and should not be used near an open flame or in a smoking area. Use only in well-ventilated areas. This solvent evaporates quickly and has a drying effect on the skin. When used without gloves, it may irritate, inflame or cause cracks in the skin.

a. Remove all lubricant from surfaces to be treated with dry cleaning solvent (item 5, app D). Wear rubber gloves (item 7, app D) and use a wash pan (item 11, app D) and brush (item 2, app D) to apply dry cleaning solvent.

## CAUTION

Do not use wire brush to roughen surface.

b. Roughen surface using abrasive cloth (item 4, app D).

c. Be sure surface to be treated is thoroughly cleaned and dried prior to application of solid film lubricant.

3-2. M7 BLADE ASSEMBLY-MAINTENANCE INSTRUCTIONS. (Cont)

INSPECTION/REPAIR (Cont)

WARNING

When using solid film lubricant, be sure area is well ventilated.

d. Apply solid film lubricant (item 8, app D) to shiny surfaces. Allow to dry 16 to 24 hours before handling.

NOTE

If solid film lubricant comes in contact with the functional surfaces of the lock-release lever, remove lubricant immediately by washing with dry cleaning solvent (item 5, app D).

3-3. M9 MULTIPURPOSE BAYONET SYSTEM--MAINTENANCE INSTRUCTIONS.

BAYONET

This task covers:

- a. Grinding
- b. Lubrication

INITIAL SETUP

Tools and special tools

Small arms field maintenance tool kit (app B)

References

Appendix B  
Appendix D

Materials/Parts

CLP (item 3, app D)  
LSA (item 10, app D)  
Wiping rag (item 12, app D)

Equipment Conditions

Blade requires grinding

GRINDING

CAUTION

M9 blade is tempered, do not overheat when grinding.

1. Check blade for nicks on the cutting edge and/or the false edge. Nicks up to 3/16-inch (0.48 cm) can be removed by grinding. Ground areas shall be blended with adjacent surfaces. Blades with deeper nicks should be replaced.

2. Repair broken point on blade by grinding. After repointing, the length of the blade (measured from the front face of the guard to the tip of the blade) must not be less than 6 3/4 inches (17.15 cm).

## 3-3. M9 MULTIPURPOSE BAYONET SYSTEM--MAINTENANCE INSTRUCTIONS. (Cont)

## BAYONET (Cont)

## LUBRICATION

## NOTE

For use of lubricant, refer to paragraph 2-4.

Wipe bayonet with wiping rag (item 12, app D) and apply a light coat of lubricant to metal parts.

## 3-4. M9 MULTIPURPOSE BAYONET SYSTEM--MAINTENANCE INSTRUCTIONS.

## SCABBARD BODY ASSEMBLY

This task covers:

- |                       |                    |
|-----------------------|--------------------|
| a. Inspection         | c. Clear/lubricate |
| b. Disassembly/repair | d. Reassembly      |

## INITIAL SETUP

## Tools and Special Tools

Small arms repairman tool set (app B)  
Small arms field maintenance tool kit  
(app B)

## References

Appendix B  
Appendix C  
Appendix D

## Materials/Parts

Abrasive Cloth (item 4, app D)  
CLP (item 3, app D)  
LSA (item 10, app D)  
Solid film lubricant (item 8, app D)  
Wiping rag (item 12, app D)

## Equipment Conditions

Cutter assembly can be removed from scabbard body assembly as received without removing other parts

## INSPECTION

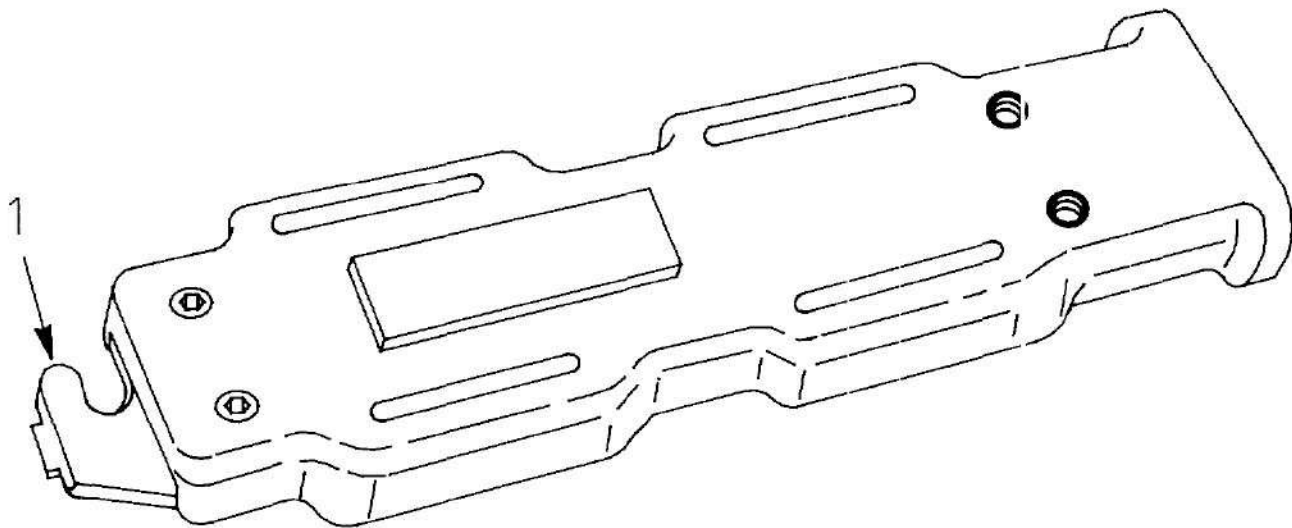

## 3-4. M9 MULTIPURPOSE BAYONET SYSTEM--MAINTENANCE INSTRUCTIONS (Cont).

## SCABBARD BODY ASSEMBLY (Cont)

## INSPECTION (Cont)

## NOTE

Cutter plate requires replacement only if it is cracked, broken, won't cut wire, or screw driver tip is damaged and won't remove bayonet cap screw.

Inspect cutter assembly (1) for nonfunctioning. If nonfunctioning, replace.

## DISASSEMBLY/REPAIR

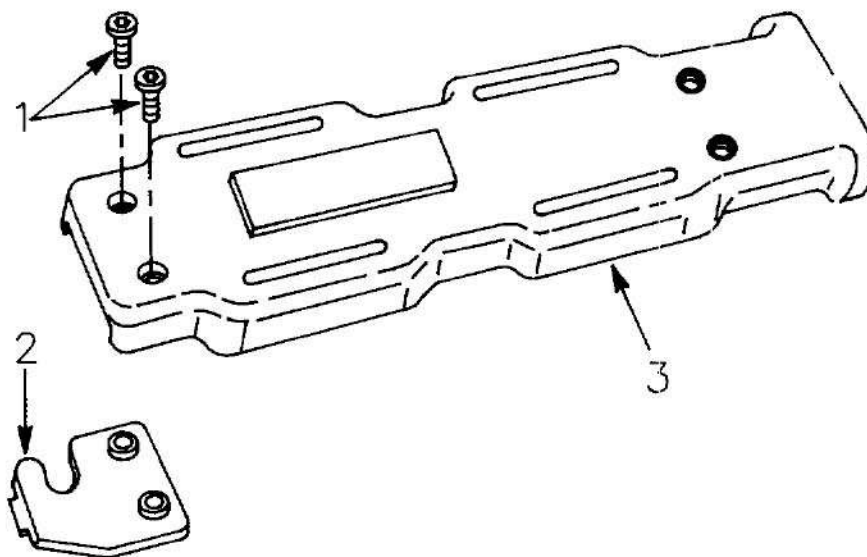

## NOTE

Remove screws only to replace cutter assembly or screws.

1. Remove 2 socket head screws (1).
2. Separate cutter assembly (2) from scabbard body assembly (3).
3. Inspect screw threads and heads for damage. If damaged, replace.
4. Inspect for worn or shiny areas on cutter assembly, re-establish finish as follows:

## WARNING

Dry cleaning solvent (A-A-711) is flammable and should not be used near an open flame or in a smoking area. Use only in well-ventilated areas. This solvent evaporates quickly and has a drying effect on the skin. When used without gloves, it may irritate, inflame or cause cracks in the skin.

- a. Remove all lubricant from surfaces to be treated with dry cleaning solvent (item 5, app D). Wear rubber gloves (item 7, app D) and use a wash pan (item 11, app D) and brush (item 2, app D) to apply dry cleaning solvent.

## 3-4. M9 MULTIPURPOSE BAYONET SYSTEM--MAINTENANCE INSTRUCTIONS (Cont).

## SCABBARD BODY ASSEMBLY (Cont)

## DISASSEMBLY (Cont)

## CAUTION

Do not use wire brush to roughen surface.

b. Roughen surface using abrasive cloth (item 4, app D).

c. Be sure surface to be treated is thoroughly cleaned and dried prior to application of solid film lubricant.

## WARNING

When using solid film lubricant, be sure area is well ventilated.

d. Apply solid film lubricant (item 8, app D) to shiny surfaces. Allow to dry 16 to 24 hours before handling.

## CLEAN/LUBRICATE

## NOTE

For use of lubricant, refer to paragraph 2-4.

Wipe scabbard with wiping rag (item 12, app D) and apply a light coat of lubricant to metal parts.

## REASSEMBLY

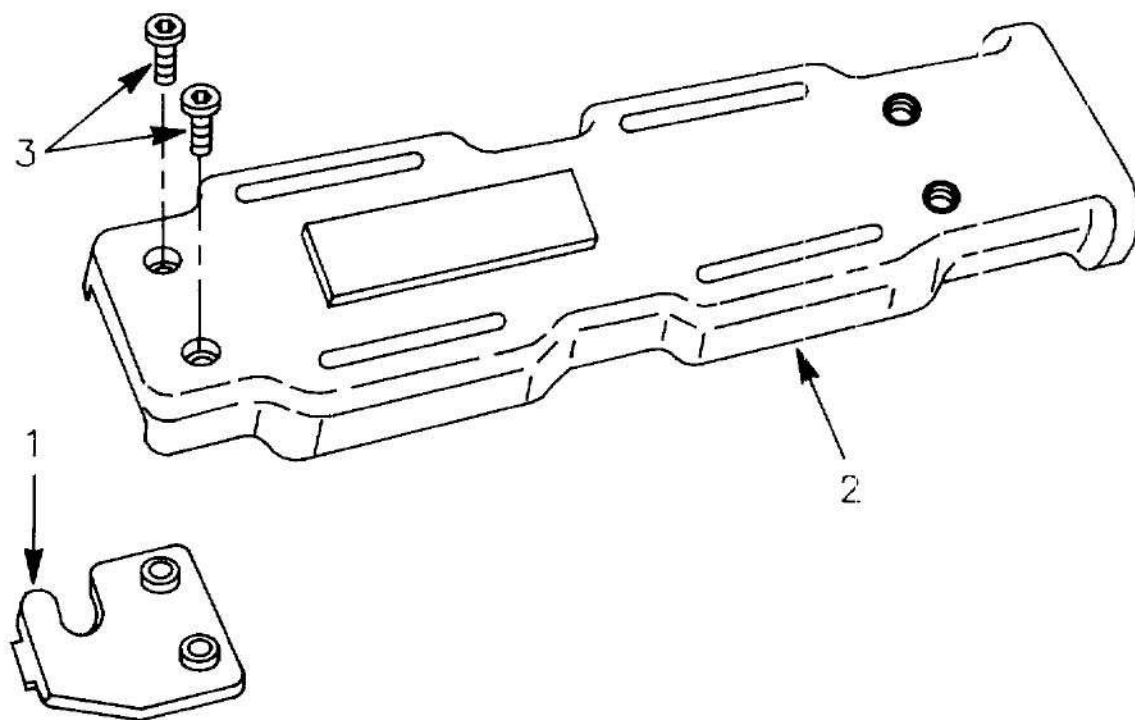

1. Install cutter assembly (1) on scabbard body assembly (2) as shown.

2. Install two socket head screws (3). Tighten two socket head screws (3).



APPENDIX A  
REFERENCES

A-1. DEPARTMENT OF THE ARMY FORMS (DA Form).

DA Form 2028 . . . . .	Recommended Changes to Publications and Blank Forms.
DA Form 2028-2 . . . . .	Recommended Changes to Equipment Technical Manuals.
DA Form 2404 . . . . .	Equipment Inspection and Maintenance Worksheet.

A-2. MISCELLANEOUS PUBLICATIONS.

CTA 8-100 . . . . .	. Army Medical Department Expendable/Durable Items.
CTA 50-970 . . . . .	Expendable/Durable Items (except Medical Class V, Repair Parts, and Heraldic Items).
DA PAM 738-750 . . . . .	The Army Maintenance Management System (TAMMS).
FM 21-11 . . . . .	First Aid for Soldiers.
SB 740-95-1 . . . . .	. Storage Serviceability Standards for AMCCOM Materiel, Tools, and Equipment.
SC 4933-95-CL-A11 . . . . .	Small Arms Tool Kit, Field Maintenance, Post, Camp and Station.
SC 5180-95-CL-AO7 . . . . .	Tool Kit, Small Arms Repairman.
SF Form 364 . . . . .	. Report of Discrepancy (ROD).
SF Form 368 . . . . .	. Quality Deficiency Report (Category 11).
TM 750-244-7 . . . . .	Procedures for Destruction of Equipment in Federal Supply Classifications 1000, 1005, 1010, 101.5, 1020, 1025, 1030, 1055, 1090 and 1095 to Prevent Enemy Use.



APPENDIX B  
 MAINTENANCE ALLOCATION CHART

Section I. INTRODUCTION

B-1. GENERAL.

- a. This section provides a general explanation of all maintenance and repair functions authorized at various maintenance categories.
- b. The maintenance allocation chart (MAC) in section II designates overall authority and responsibility for the performance of maintenance functions on the identified end item or component. The application of the maintenance functions to the end item or component will be consistent with the capacities and capabilities of the designated maintenance categories.
- c. Section III lists the tools and test equipment (both special tools and common tool sets) required for each maintenance function, as referenced from section 11.
- d. Section IV contains supplemental instructions and explanatory notes for a particular maintenance function.

B-2. MAINTENANCE FUNCTIONS.

Maintenance functions will be limited to and defined as follows, (except for ammunition MAC\*).

- a. Inspect. To determine the serviceability of an item by comparing its physical, mechanical, and/or electrical characteristics with established standards through examination (e.g., by sight, sound, or feel).
- b. Test. To verify serviceability by measuring the mechanical, pneumatic, hydraulic, or electrical characteristics of an item and comparing those characteristics with prescribed standards.
- c. Service. Operations required periodically to keep an item in proper operating condition, i.e., to clean (includes decontaminate, when required), to preserve, to drain, to paint, or to replenish fuel, lubricants, chemical fluids, or gases.
- d. Adjust. To maintain or regulate, within prescribed limits, by bringing into proper or exact position, or by setting the operating characteristics to specified parameters.
- e. Aline. To adjust specified variable elements of an item to bring about optimum or desired performance.

\*Exception is authorized for ammunition MAC to permit the redesignation/redefinition of maintenance function headings to more adequately identify ammunition maintenance functions. The heading designations and definitions will be included in the appropriate technical manual for each category of ammunition.

## B-2. MAINTENANCE FUNCTIONS. (cont)

f. Calibrate. To determine and cause corrections to be made or to be adjusted on instruments or test, measuring, and diagnostic equipments used in precision measurement. Consists of comparisons of two instruments, one of which is a certified standard of known accuracy, to detect and adjust any discrepancy in the accuracy of the instrument being compared.

g. Remove/Install. To remove and install the same item when required to perform service or other maintenance functions. Install may be the act of emplacing, seating or fixing into position a spare, repair part, or module (component or assembly) in a manner to allow the proper functioning of an equipment or system.

h. Replace. To remove an unserviceable item and install a serviceable counterpart in its place. "Replace" is authorized by the MAC and is shown as the 3d position code of the SMR code.

i. Repair. The application of maintenance services\*, including fault location/trouble-shooting\*, removal/installation, and disassembly/assembly\* procedures, and maintenance actions\* to identify troubles and restore serviceability to an item by correcting specific damage, fault, malfunction, or failure in a part, subassembly, module (component or assembly), end item, or system.

j. Overhaul. That maintenance effort (service/action) prescribed to restore an item to a completely serviceable/operational condition as required by maintenance standards in appropriate technical publications (i.e. DMWR). Overhaul is normally the highest degree of maintenance performed by the Army. Overhaul does not normally return an item to like new condition.

k. Rebuild. Consists of those services/actions necessary for the restoration of unserviceable equipment to a like new condition in accordance with original manufacturing standards. Rebuild is the highest degree of materiel maintenance applied to Army equipment. The rebuild operation includes the act of returning to zero those age measurements (hours/miles, etc.) considered in classifying Army equipment/components.

## B-3. EXPLANATION OF COLUMNS IN THE MAC, SECTION II.

a. Column 1, Group Number. Column I lists functional group code numbers, the purpose of which is to identify maintenance significant components, assemblies, subassemblies, and modules with the next higher assembly. End item group number shall be "00".

\*Services-inspect, test, service, adjust, align, calibrate, and/or replace.

\*Fault locate/troubleshoot--The process of investigating and detecting the cause of equipment malfunctioning, the act of isolating a fault within a system or unit under test (UUT). \*Disassemble/assemble--Encompasses the step-by-step taking apart (or breakdown) of a spare/functional group coded item to the level of its least component identified as maintenance significant (i.e., assigned an SMR code) for the category of maintenance under consideration. \*Actions--welding, grinding, riveting, straightening, facing, remachining, and/or resurfacing.

b. Column 2, Component/Assembly. Column 2 contains the names of components, assemblies, subassemblies, and modules for which maintenance is authorized.

c. Column 3. Maintenance Function. Column 3 lists the functions to be performed on the item listed in column 2. (For detailed explanation of these functions, see paragraph B-2.)

d. Column 4, Maintenance Category. Column 4 specifies, by the listing of a work time figure in the appropriate subcolumn(s), the category of maintenance authorized to perform the function listed in column 3. This figure represents function at the indicated category of maintenance. If the number or complexity of the tasks within the listed maintenance function vary at different maintenance categories, appropriate work time figures will be shown for each category. The work time figure represents the average time required to restore an item (assembly, subassembly, component, module, end item, or system) to a serviceable condition under typical field operating conditions. This time includes preparation time (including any necessary disassembly/assembly time), trouble-shooting/fault location time, and quality assurance/quality control time in addition to the time required to perform the specific tasks identified for the maintenance functions authorized in the maintenance allocation chart. The symbol designations for the various maintenance categories are as follows.

- C. . . . . Operator or crew
- O. . . . . Organizational maintenance
- F. . . . . Direct support maintenance
- H. . . . . General support maintenance
- L. . . . . Specialized repair activity  
(SRA)\*
- D. . . . . Depot maintenance

\*This maintenance category is not included in section II, column (4) of the maintenance allocation chart. To identify functions to this category of maintenance, enter a work time figure in the H- column of section II, column (4), and use an associated reference code in the remarks column (6) , Key the code to section IV, remarks, and explain the SRA complete repair application there. The explanatory remark(s) shall reference the specific. repair parts and special tools list (RPSTL) TM which contains additional SRA criteria anti the authorized spare/repair parts.

e. Column 5, Tools and Equipment. Column 5 specifies, by code, those common tool sets (not individual tools) and special tools, TMDE, and support equipment required to perform the designated function.

f. Column 6, Remarks. This column shall, when applicable, contain a letter code, in alphabetic order, which shall be keyed to the remarks contained in section IV.

B-4. EXPLANATION OF COLUMNS IN TOOL AND TEST EQUIPMENT REQUIREMENTS, SECTION III.

a. Column 1, Reference Code. The tool and test equipment reference code correlates with a code used in the MAC, section II, Column 5.

b. Column 2, Maintenance Category. The lowest category of maintenance authorized to use the tool or test equipment.

c. Column 3, Nomenclature. Name or identification of the tool or test equipment.

d. Column 4, National Stock Number. The National stock number of the tool or test equipment.

e. Column 5, Tool Number. The manufacturer's part number.

B-5. EXPLANATION OF COLUMNS IN REMARKS, SECTION IV.

a. Column 1, Reference Code. The code recorded in column 6, section II.

b. Column 2, Remarks. This column lists information pertinent to the maintenance function being performed as indicated in the MAC, section II.

Section II. MAINTENANCE ALLOCATION CHART  
 FOR  
 M6 BAYONET-KNIFE WITH SCABBARD,  
 M7 BAYONET-KNIFE WITH SCABBARD AND  
 M9 MULTIPURPOSE BAYONET SYSTEM

(1) GROUP NUMBER	(2) COMPONENT/ASSEMBLY	(3) MAINTENANCE FUNCTION	(4) MAINTENANCE CATEGORY					(5) TOOLS AND EQPT	(6) REMARKS
			UNIT C	O	D.S. F	G.S. H	DEP. D		
00	M6, M7, M9, and M10	INSPECT	0.1	0.1				1	
		SERVICE REPLACE REPAIR	0.1	0.1				1	
01	M6	INSPECT	0.1	0.1	0.1			1	
		SERVICE REPLACE REPAIR	0.1	0.1	0.2			1,2	

(1) GROUP NUMBER	(2) COMPONENT/ASSEMBLY	(3) MAINTENANCE FUNCTION	(4) MAINTENANCE CATEGORY					(5) TOOLS AND EQPT	(6) REMARKS
			UNIT C	O	D.S. F	G.S. H	DEP. D		
02	M7	INSPECT SERVICE REPLACE REPAIR	0.1 0.1	0.1 0.1	0.1			1 1 1	
0201	M7 BLADE ASSEMBLY	INSPECT REPAIR			0.1 0.2			1 1,2	
03	M10	INSPECT SERVICE REPLACE REPAIR	0.1 0.1	0.1 0.1					
04	M9	INSPECT SERVICE REPAIR	0.1 0.1	0.1 0.1	0.1 0.1			1 1,2	
0401	LATCH ASSEMBLY	INSPECT REMOVE/INST REPLACE REPAIR		0.1 0.1 0.1 0.1				1 1 1 1	
05	M9 SCABBARD	INSPECT SERVICE REPAIR	0.1 0.1	0.1 0.1				1 1	
0501	M9 SCABBARD BODY ASSEMBLY	INSPECT REPAIR		0.1 0.1	0.1 0.1			1 1	

## SECTION III. TOOL AND TEST EQUIPMENT REQUIREMENTS

FOR

M6 BAYONET-KNIFE WITH SCABBARD,  
 M7 BAYONET-KNIFE WITH SCABBARD AND  
 M9 MULTI PURPOSE BAYONET SYSTEM

TOOL OR TEST EQUIPMENT REF CODE	MAINTENANCE CATEGORY	NOMENCLATURE	NATIONAL/ NATO STOCK NUMBER	TOOL NUMBER
1	0	TOOL KIT, SMALL ARMS REPAIRMAN	4933-00-357-7770	SC 5180- 95-CL-A07
2	F	TOOL KIT, SMALL AMRS, FIELD MAINTENANCE, POST, CAMP AND STATION	4933-00-754-0664	SC 4933- 95-CL-A11

## APPENDIX C ORGANIZATIONAL AND DIRECT SUPPORT MAINTENANCE

## REPAIR PARTS AND SPECIAL TOOLS LIST

## Section I. INTRODUCTION

## C-1. SCOPE.

This RPSTL lists and authorizes spares and repair parts, special tools; special test, measurement, and diagnostic equipment (TMDE), and other special support equipment required for performance of organizational and direct support maintenance of the M6 Bayonet-knife with M10 Bayonet-knife Scabbard, M7 Bayonet-knife with M10 Bayonet-knife Scabbard, and M9 Multipurpose Bayonet. System. It authorizes the requisition, issue, and disposition of spares, repair parts and special tools as indicated by the source, maintenance and recoverability (SMR) codes.

## C-2. GENERAL.

In addition to Section I. Introduction, this repair parts and special tools list is divided into the following sections:

a. Section II. Repair Parts List, A list of spares and repair parts authorized by this RPSTL for use in the performance of maintenance. The list also includes parts which must be removed for replacement of the authorized parts. Parts lists are composed of functional groups in ascending alphanumeric sequence, with the parts in each group listed in ascending figure and item number sequence. Bulk materials are listed by item name in FIG BULK at the end of the section. Repair parts kits or sets are listed separately in their own functional group within section II. Repair parts for repairable special tools are also listed in this section.

b. Section III. Special Tools List. A list of special tools, special TMDE, and other special support equipment authorized by this RPSTL (as indicated by Basis of Issue (BOI) information in DESCRIPTION AND USABLE ON CODE (UOC) column) for the performance of maintenance.

c. Section IV. National Stock Number and Part Number Index. A list, in National item identification number (NIIN) sequence, of all National stock numbered items appearing in the listings, followed by a list in alphanumeric sequence of all part numbers appearing in the listing. National stock numbers and part numbers are cross-referenced to each illustration figure and item number appearance.

## C-3. EXPLANATION OF COLUMNS (SECTIONS II AND III).

a. Item No. (Column (1)). Indicates the number used to identify items called out in the illustration.

b. SMR Code (Column (2)). The Source, Maintenance, and Recoverability (SMR) code is a 5-position code containing supply/requisitioning information, maintenance category authorization criteria, and disposition instruction, as shown in the following breakout:

## C-3. EXPLANATION OF COLUMNS (SECTIONS II AND III). (cont)

Source Code	Maintenance Code		Recoverability Code
1st two positions	3d position	4th position	5th position
How you get an item	Who can install, replace or use the item	Who can do complete repair* on the item	Who determines disposition action on an unserviceable item

(1) Source Code. The source code tells you how to get an item needed for maintenance, repair, or overhaul of an end item/equipment. Explanations of source codes follow:

Code	Explanation
PA	
PB	
PC**	Stocked items, use the applicable NSN to request/requisition items with these source codes. They are authorized to the category indicated by the code entered in the 3d position of the SMR code.
PD	
PE	
PF	
PG	
KD	Items with these codes are not to be requested/requisitioned individually. They are part of a kit which is authorized to the maintenance category indicated in the 3d position of the SMR code. The complete kit must be requisitioned and applied.
KF	
KB	

Code	Explanation
MO-(Made at Org/ AVUM Level)	Items with these codes are not to be requested/requisitioned individually. They must be made from bulk material which is identified by the part number in DESCRIPTION AND USABLE ON CODE (UOC) column and listed in the bulk material group of the repair parts list in this RPSTL. If the item is authorized to you by the 3d position code of the SMR code, but the source code indicates it is made at a higher level, order the item from the higher level of maintenance.
MF-(Made at Intro DS/ AVIM Level)	
MH-(Made at Intro GS level)	
ML-(Made at Spe- cialized Repair Activity (SRA))	
MD-(Made at Depot)	

\*Complete Repair, Maintenance capacity, capability, and authority to perform all corrective maintenance tasks of the "Repair" function in a use/user environment in order to restore serviceability to a failed item.

\*\*NOTE, Items coded PC are subject to deterioration.

AO- (Assembled by Org/AVUM Level) Items with these codes are not to be requested/requisitioned individually. The parts that make up the assembled item must be requisitioned or fabricated and assembled at the level of maintenance indicated by the source code. If the 3d position code of the SMR code authorizes you to replace the item, but the source code indicates the item is assembled at a higher level, order the item from the higher level of maintenance.

AF- (Assembled by Intro DS/AVIM Level)

AH- (Assembled by Intro GS Category)

AL- (Assembled by SRA)

AD- (Assembled by Depot)

XA - Do not requisition an "XA'-coded item. Order its next higher assembly. (Also, refer to the NOTE below.)

XB - If an -XB- item is not available from salvage, order it using the FSCM and part number given.

xc - Installation drawing, diagram, instruction sheet, field service drawing, that is identified by manufacturer's part number.

XD - Item is not stocked. Order an "XD--coded item through normal supply channels using the FSCM and part number given, if no NSN is available.

NOTE : Cannibalization or controlled exchange, when authorized, may be used as a source of supply for items with the above source codes, except for those source coded "XA' or those aircraft support items restricted by requirements of AR 700-42.

(2) Maintenance Code. Maintenance codes tell you the level(s) of maintenance authorized to USE and REPAIR support items. The maintenance codes are entered in the third and fourth positions of the SMR Code as follows:

(a) The maintenance code entered in the third position tells you the lowest maintenance level authorized to remove, replace, and use an item. The maintenance code entered in the fourth position will indicate authorization to one of the following levels of maintenance.

Code	Application/Explanation
C	Crew or operator maintenance done within organizational or aviation unit maintenance.
O	Organizational or aviation unit category can remove, replace, and use the item.
F	Intermediate direct support or aviation intermediate level can remove, replace, and use the item.
H	Intermediate general support level can remove, replace, and use the item.
L	Specialized repair activity can remove, replace, and use the item.
D	Depot level can remove, replace, and use the item.

C-3. EXPLANATION OF COLUMNS (SECTIONS II AND III). (cont)

(b) The maintenance code entered in the fourth position tells whether or not the item is to be repaired and identifies the lowest maintenance level with the capability to do complete repair (i.e., perform all authorized repair functions).

(NOTE: Some limited repair may be done on the item at a lower level of maintenance, if authorized by the Maintenance Allocation Chart (MAC) and SMR codes.) This position will contain one of the following maintenance codes.

Code	Application/Explanation
O	Organizational or aviation unit is the lowest level that can do complete repair of the item.
F	Intermediate direct support or aviation intermediate is the lowest level that can do complete repair of the item.
H	Intermediate general support is the lowest level that can do complete repair of the item.
L	Specialized repair activity is the lowest level that can do complete repair of the item.
D	Depot is the lowest level that can do complete repair of the item.
Z	Nonreparable. No repair is authorized.
B	No repair is authorized. (No parts or special tools are authorized for the maintenance of a "B" coded item.) However, the item may be reconditioned by adjusting, lubricating, etc. , at the user level.

(3) Recoverability Code. Recoverability codes are assigned to items to indicate the disposition action on unserviceable items. The recoverability code is entered in the fifth position of the SMR Code as follows:

Recoverability Codes	Application/Explanation
z	Nonreparable item. When unserviceable., condemn and dispose of the item at the level of maintenance shown in 3d position of SMR Code.
O	Reparable item. When uneconomically repairable, condemn and dispose of the item at organizational or aviation unit level.
F	Reparable item. When uneconomically repairable, condemn and dispose of the item at intermediate direct support or aviation. intermediate level.
H	Reparable item. When uneconomically repairable, condemn and dispose of the item at intermediate general support level.

- D           Reparable item. When beyond lower level repair capability, return to depot. Condemnation and disposal of item not authorized below depot level.
- L           Reparable item. Condemnation and disposal not authorized below specialized repair activity (SRA).
- A           Item requires special handling or condemnation procedures because of specific reasons (e.g., precious metal content, high dollar value, critical material, or hazardous material). Refer to appropriate manuals/directives for specific instructions.

c. CAGEC (Column (3)). The Contractor and Government Entity Code (CAGEC) is a 5-digit numeric code which is used to identify the manufacturer, distributor, or Government agency, etc., that supplies the item.

d. Part Number (Column (4)). Indicates the primary number used by the manufacturer (individual, company, firm, corporation, or Government activity), which controls the design and characteristics of the item by means of its engineering drawings, specifications standards, and inspection requirements to identify an item or range of items.

NOTE: When you use an NSN to requisition an item, the item you receive may have a different part number from the part ordered.

e. Description and Usable On Code (UOC) (Column (5)). This column includes the following information:

(1) The Federal item name and, when required, a minimum description to identify the item.

(2) The physical security classification of the item is indicated by the parenthetical entry which is a physical security classification abbreviation (e.g., Phy Sec C1 (C)-Confidential, Phy Sec C1 (S)-Secret, Phy Sec C1 (T)-Top Secret).

(3) Items that are included in kits and sets are listed below the name of the kit or set.

(4) Spare/repair parts that make up an assembled item are listed immediately following the assembled item line entry.

(5) Part numbers for bulk materials are referenced in this column in the line item entry for the item to be manufactured/fabricated,

(6) When the item is not used with all serial numbers of the same model, the effective serial numbers are shown on the last line(s) of the description (before UOC).

(7) The usable on code, when applicable. (See paragraph 5, special information.)

(8) In the special tools list section, the basis of issue (BOI) appears as the last line(s) in the entry for each special tool, special TMDE, and other special support equipment. When density of equipment supported exceeds density spread indicated in the basis of issue, the total authorization is increased proportionately.

(9) The statement "END OF FIGURE" appears just below the last item description in Column 5 for a given figure in both section II and section III.

f. Qty (Column (6)). The QTY (quantity per figure column) indicates the quantity of the item used in the breakout shown on the illustration figure, which is prepared for a functional group, subfunctional group, or an assembly. A "V" appearing in this column in lieu of a quantity indicates that the quantity is variable and the quantity may vary from application to application.

#### C-4. EXPLANATION OF COLUMNS (SECTION IV).

##### a. National Stock Number (NSN) Index.

(1) Stock Number Column. This column lists the NSN by National item identification number (NIIN) sequence. The NIIN consists of the last nine digits of the NSN (i.e., 5305-01-674-1467). When using this column to locate an item, ignore the first 4 digits of the NSN. However, the complete NSN should be used when ordering items by stock number.

(2) Fig. column. This column lists the number of the figure where the item is identified/located. The figures are in numerical order in section II and section III.

(3) Item column. The item number identifies the item associated with the figure listed in the adjacent FIG. column. This item is also identified by the NSN listed on the same line,

b. Part Number Index, Part numbers in this index are listed by part number in ascending alphanumeric sequence (i.e., vertical arrangement of letter and number combination which places the first letter or digit of each group in order A through Z, followed by the numbers 0 through 9 and each following letter or digit in like order).

(1) CAGEC (Column (3)). The Contractor and Government Entity Code (CAGEC) is a 5-digit numeric code which is used to identify the manufacturer, distributor, or Government agency, etc., that supplies the item.

(2) Part Number Column. Indicates the primary number used by the manufacturer (individual, firm, corporation, or Government activity), which controls the design and characteristics of the item by means of its engineering drawings, specifications standards, and inspection requirements to identify an item or range of items.

(3) Stock Number Column. This column lists the NSN for the associated part number and manufacturer identified in the PART NUMBER and FSCM columns to the left.

(4) Fig. Column. This column lists the number of the figure where the item is identified/located in sections II and III.

(5) Item Column. The item number is that number assigned to the item as it appears in the figure referenced in the adjacent figure number column.

#### C-5. SPECIAL INFORMATION.

Usable On Code. The usable on code appears in the lower left corner of the description column heading. Usable on codes are shown as "UOC: . . . . ." in the description column (justified left) on the first line applicable item description/nomenclature. Uncoded items are applicable to all models. Identification of the usable on codes used in this publication are:

Code	Used On
536	M6 Bayonet-Knife/w M10 Scabbard
538	M7 Bayonet-Knife/w M10 Scabbard
AE2	M9 Multipurpose. Bayonet System (MPBS)

#### C-6. HOW TO LOCATE REPAIR PARTS.

##### a. When National Stock Number or Part Number is Not Known.

(1) First. Using the table of contents, determine the assembly group or sub-assembly group to which the item belongs. This is necessary since figures are prepared for assembly groups and subassembly groups, and listings are divided into the same groups.

(2) Second. Find the figure covering the assembly group or subassembly group to which the item belongs.

(3) Third. Identify the item on the figure and note the item number.

(4) Fourth. Refer to the repair parts list for the figure to find the part number for the item number noted on the figure.

(5) Fifth. Refer to the part number index to find the NSN, if assigned.

##### b. When National Stock Number or Part Number is Known.

(1) First. Using the index of National stock numbers and part numbers, find the pertinent National stock number or part number. The NSN index is in National item identification number (NIIN) sequence. (See 4. 1(1).) The part numbers in the part number index are listed in ascending alphanumeric sequence. (See 4.b.) Both indexes cross-reference you to the illustration figure and item number of the item you are looking for.

(2) Second. After finding the figure and item number, verify that the item is the one you're looking for, then locate the item number in the repair parts list for the figure.

#### C-7. ABBREVIATIONS.

Not applicable.



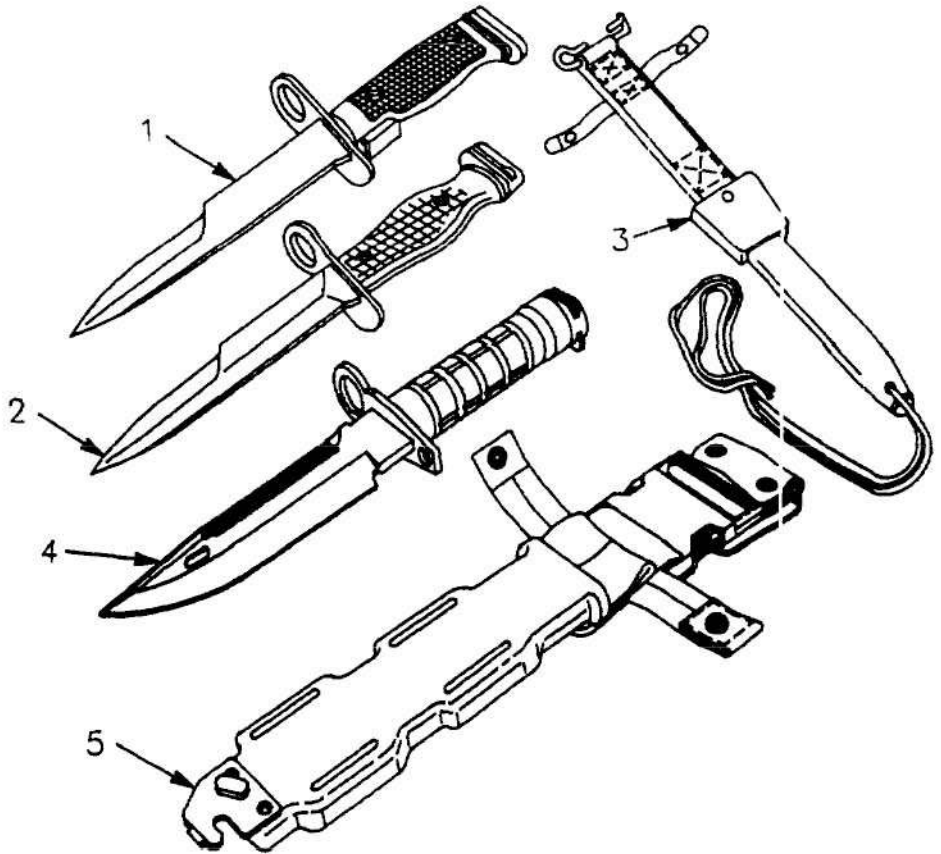

FIG. C-1 BAYONET-KNIFE WITH M10 SCABBARD, M6 8427015 & M7 8427025 & M9 MULTIPURPOSE BAYONET SYSTEM 12011860

(1) ITEM NO	(2) SMR CODE	(3) CAGEC	(4) PART NUMBER	(5) DESCRIPTION AND USABLE ON CODES(UOC)	(6) QTY
GROUP 00					
FIG. C-1 BAYONET-KNIFE WITH M10 SCABBARD, M6 8427015 & M7 8427025 & M9 MULTIPURPOSE BAYONET SYSTEM 12011860					
1	PAOFF	19204	7267616	BAYONET-KNIFE UOC:536	1
2	PAOFF	19204	11010077	BAYONET-KNIFE MI UOC:538	1
3	PAOOO	19204	8448476	SCABBARD, BAYONET-KN KNIFE, M10 (NOTE:1 SCABBARD PER BAYONET, USEABLE WITH M6 & M7 ONLY) UOC:536,538	2
4	XAOFF	19200	12011861	KNIFE, BAYONET ASSY ASSEMBLY M9 UOC:AE2	1
5	XAOFF	19200	12011862	SCABBARD, KNIFE, BAYO BAYONET (M9) UOC:AE2	1

END OF FIGURE

C-1-1

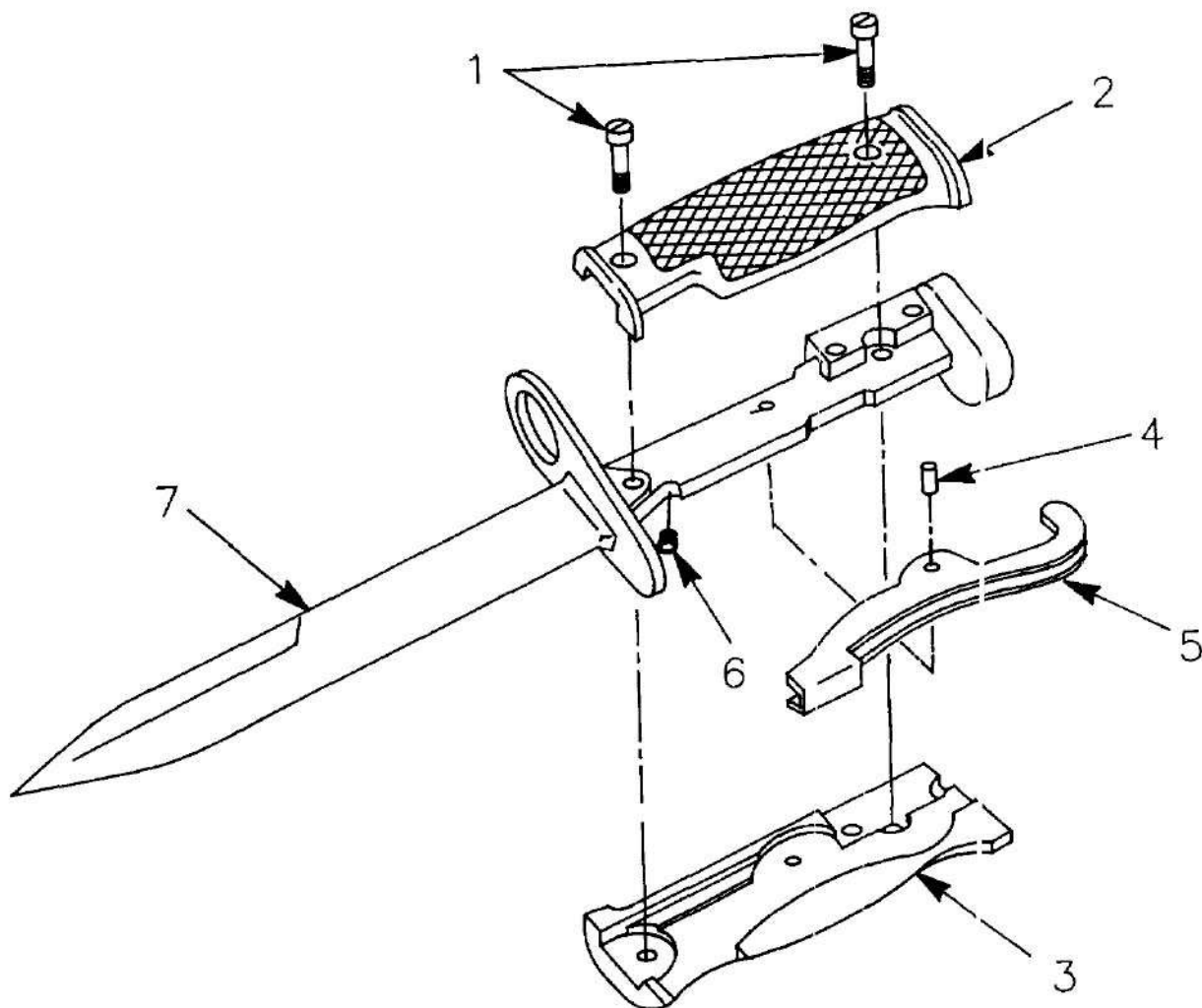

FIG. C-2 BAYONET-KNIFE, M6 7267616

(1) ITEM NO	(2) SMR CODE	(3) CAGEC	(4) PART NUMBER	(5) DESCRIPTION AND USABLE ON CODES(UOC)	(6) QTY
GROUP 01					
FIG.C-2 BAYONET-KNIFE, M6 7267616					
1	PAOZZ	19204	11010078	SCREW,MACHINE GRIP . . . . .	2
				UOC:536,538	
2	PAOZZ	19204	7267653	GRIP,BAYONET-KNIFE LF . . . . .	1
				UOC:536	
3	PAOZZ	19204	7267652	GRIP,BAYONET-KNIFE RF . . . . .	1
				UOC:536	
4	PAOZZ	96906	MS16562-125	PIN,SPRING. . . . .	1
				UOC:536	
5	XAOZZ	19204	7267648	LEVER,LOCK-RELEASE LATCHING . . . . .	1
				UOC:536	
6	XAOZZ	19205	7267645	SPRING,HELICAL,COMP (COMPRESSION 8 1/2 TOTAL COILS . . . . .	1
				UOC:536	
7	XAOZZ	19205	7267649	BLADE ASSEMBLY M6 . . . . .	1
				UOC:536	

END OF FIGURE

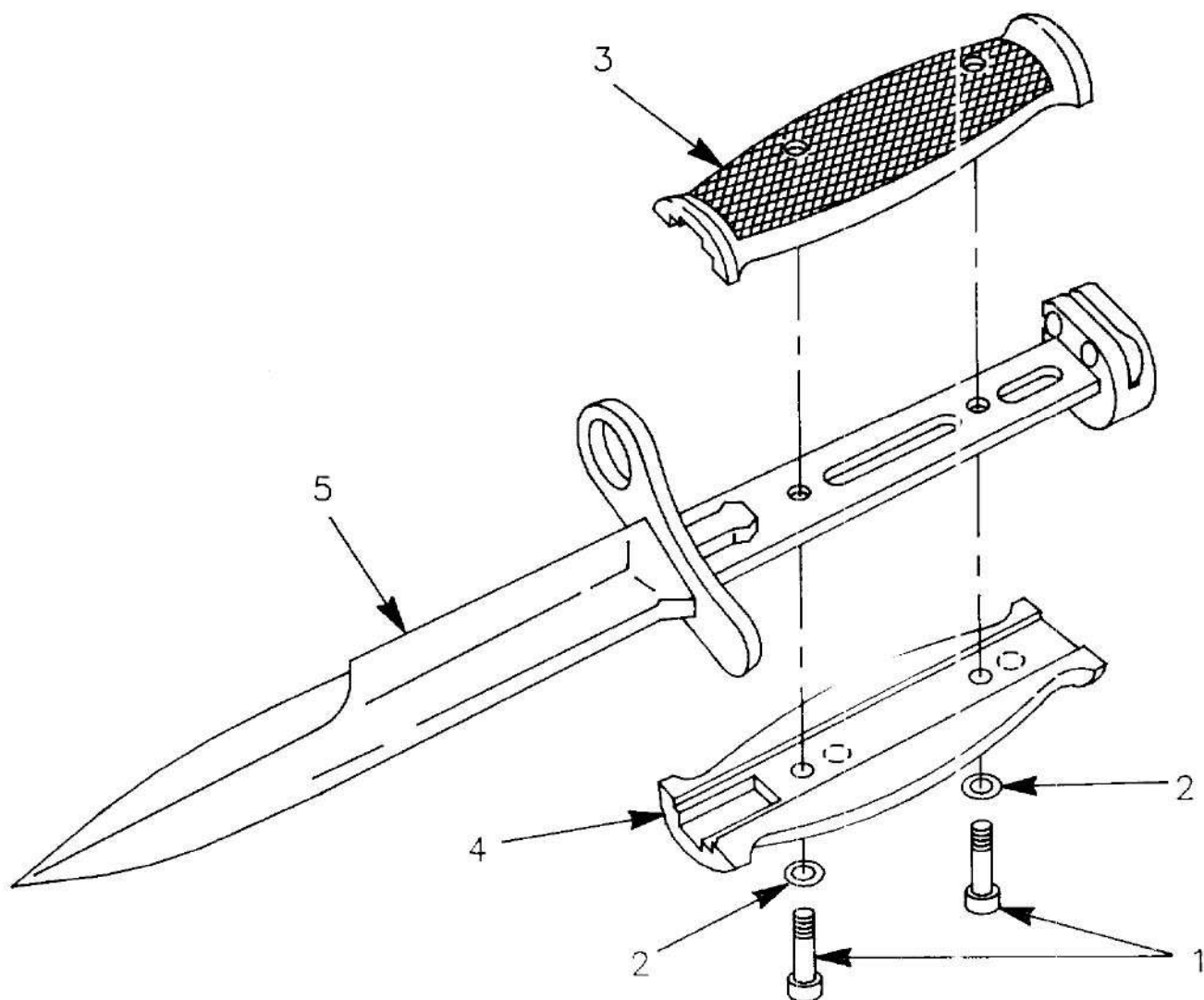

FIG. C-3 BAYONET-KNIFE, M7 11010077

(1) ITEM NO	(2) SMR CODE	(3) CAGEC	(4) PART NUMBER	(5) DESCRIPTION AND USABLE ON CODES(UOC)	(6) QTY
GROUP 02					
FIG.C-3 BAYONET-KNIFE, M7 11010077					
1	PAOZZ	19204	11010078	SCREW,MACHINE GRIP . . . . .	2
				UOC:536,538	
2	PAOZZ	96906	MS35333-37	WASHER,LOCK . . . . .	2
				UOC:538	
3	PAOZZ	19204	11010068	GRIP,BAYONET-KNIFE LH . . . . .	1
				UOC:538	
4	PAOZZ	19204	11010069	GRIP,BAYONET-KNIFE RH . . . . .	1
				UOC:538	
5	XAOFF	19204	11010067	BLADE ASSEMBLY M7 . . . . .	1
				UOC:538	

END OF FIGURE

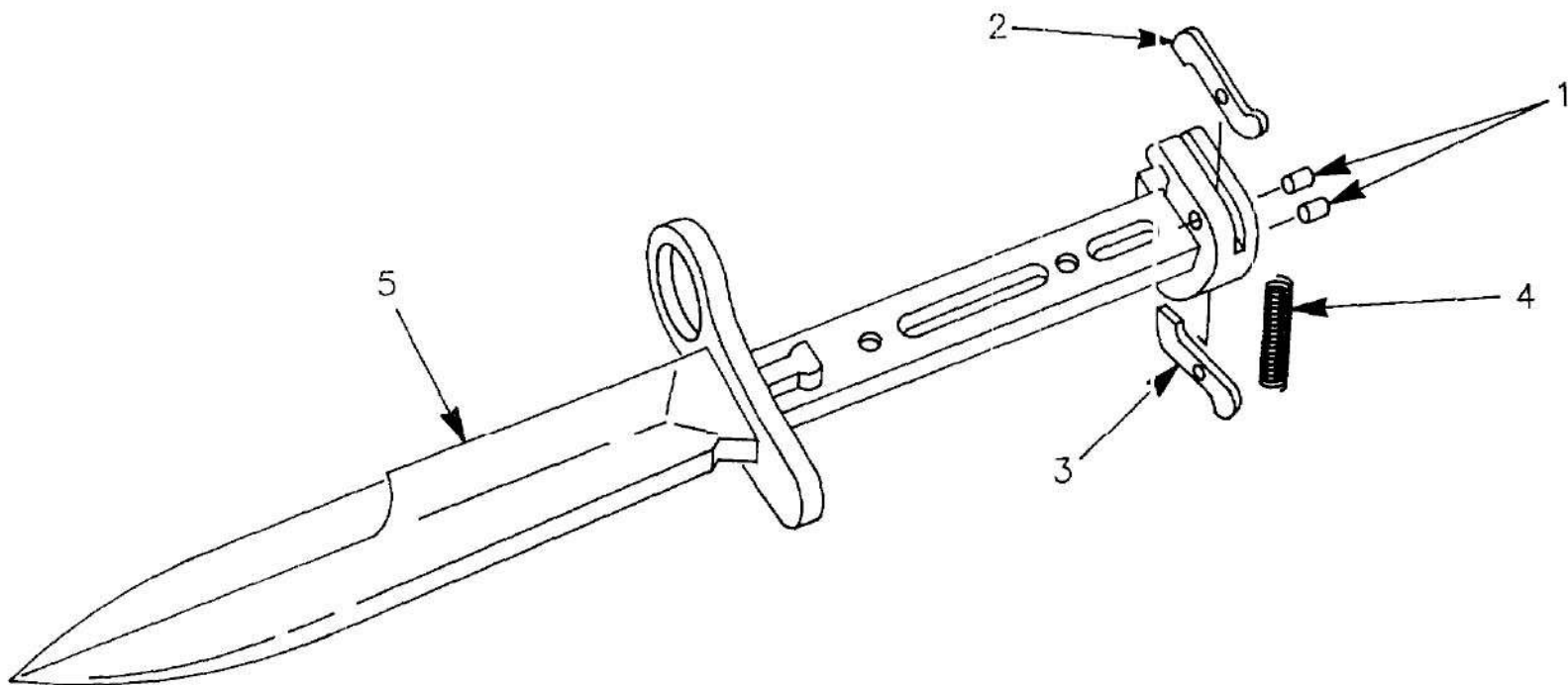

FIG. C-4 BLADE ASSEMBLY, M7 11010067

(1) ITEM NO	(2) SMR CODE	(3) CAGEC	(4) PART NUMBER	(5) DESCRIPTION AND USABLE ON CODES(UOC)	(6) QTY
GROUP 0201					
FIG.C-4 BLADE ASSEMBLY, M7 11010067					
1	PAOZZ	96906	MS16562-125	PIN, SPRING.....	2
				UOC:538	
2	PAOZZ	19204	11010011	LEVER, LOCK-RELEASE BAYONET LH . . . . .	1
				UOC:AE2, 538	
3	PAOZZ	19204	11010010	LEVER, LOCK-RELEASE BAYONET RH . . . . .	1
				UOC:AE2, 538	
4	PAOZZ	19205	7160949	SPRING, HELICAL, COMP COMPRESSION . . . . .	1
				UOC:538	
5	XAOZZ	19204	11010066	BLADE , BAYONET-KNIF E . . . . .	1
				UOC:538	

END OF FIGURE

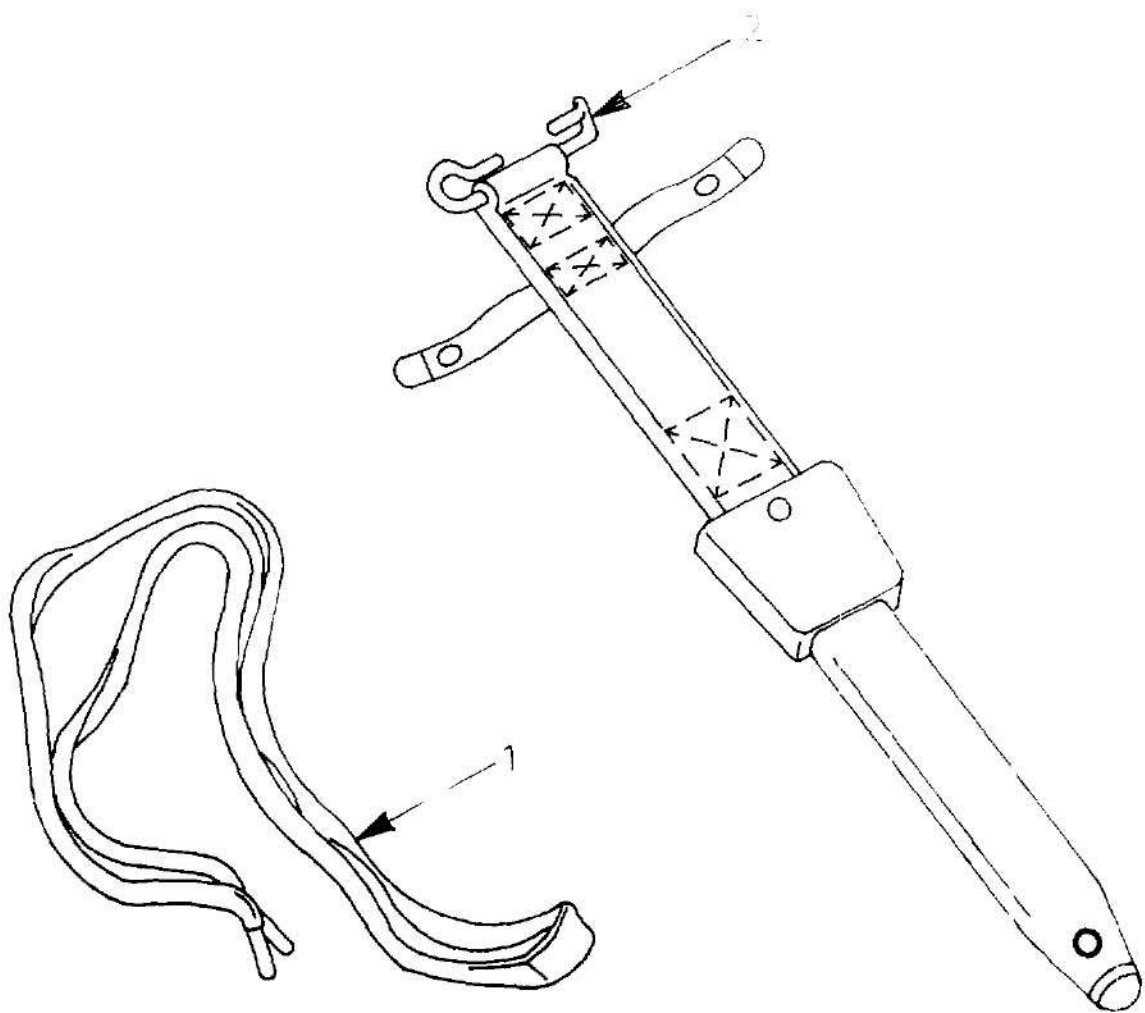

FIG. C-5 SCABBARD, BAYONET-KNIFE, M10 8448476

(1) ITEM NO	(2) SMR CODE	(3) CAGEC	(4) PART NUMBER	(5) DESCRIPTION AND USABLE (N CODES(UOC)	(6) QTY
				GROUP 03 FIG.C-5 SCABBARD, BAYONET-KNIFE M10 8448476	
1	PAOZZ	19204	7267136-2	LACE,RESTRAINING, SC SCABBARD . . . . .	1
2	XAOZZ		NPN	SCABBARD,BAYONET-KN KNIFE. . . . .	1
				UOC:536,538	

END OF FIGURE

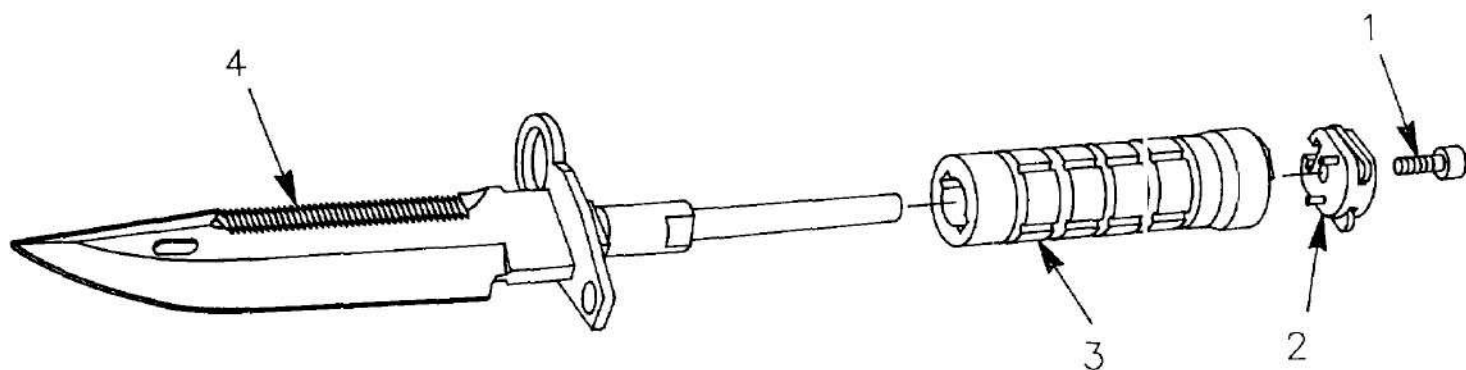

FIG. C-6 BAYONET-KNIFE ASSEMBLY, M9 12011861

(1) ITEM NO	(2) SMR CODE	(3) CAGEC	(4) PART NUMBER	(5) DESCRIPTION AND USABLE ON CODES(UOC)	(6) QTY
GROUP 04					
FIG.C-6 BAYONET-KNIFE ASSEMBLY, M9					
12011861					
1	PAOZZ	19200	12598171	SCREW,CAP, SOCKET HEAD. . . . .	1
				UOC :AE2	
2	XA000	19200	12598168	LATCH ASSEMBLY . . . . .	1
				UOC :AE2	
3	PAOZZ	19200	12598170	HANDLE . . . . .	1
				UOC : AE2	
4	XAOFF	19200	12598166	BLADE,ASSEMBLY . . . . .	1
				UOC : AE2	

END OF FIGURE

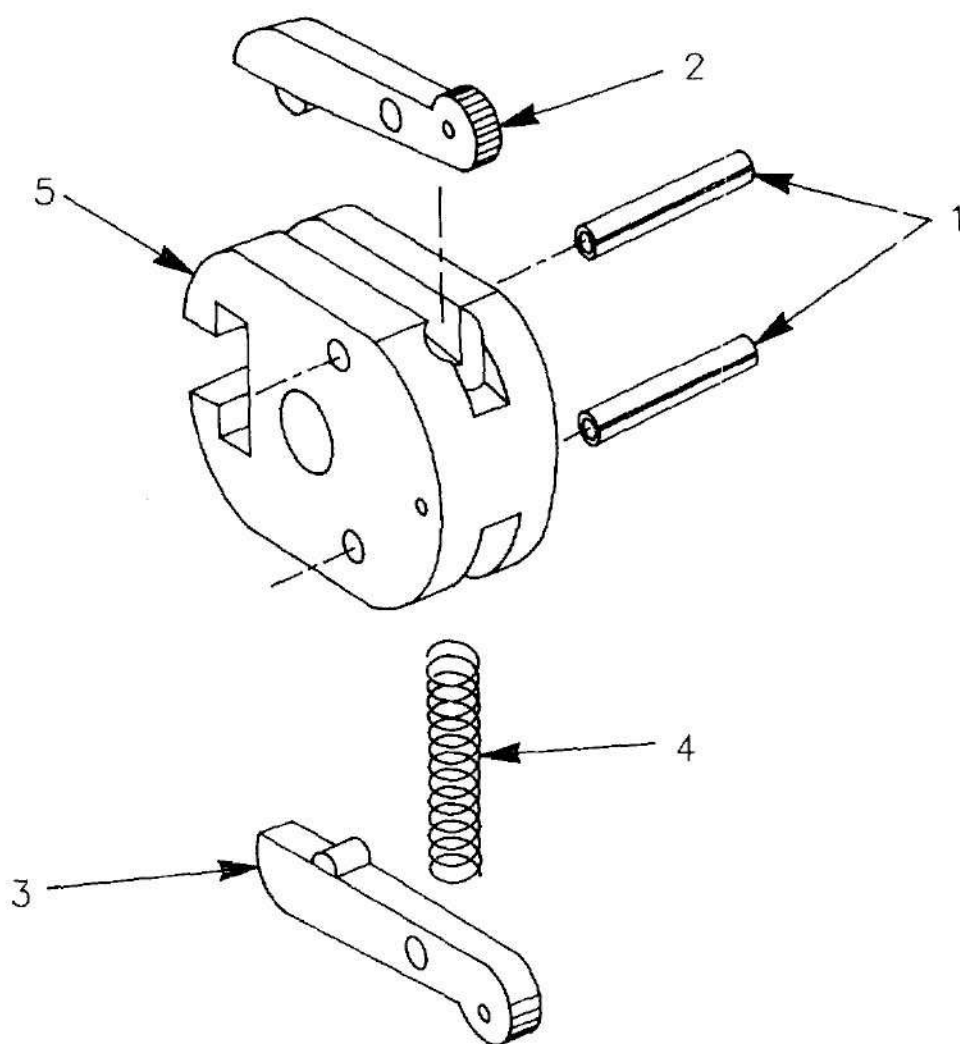

FIG. C-7 LATCH ASSEMBLY 12598168

(1) ITEM NO	(2) SMR CODE	(3) CAGEC	(4) PART NUMBER	(5) DESCRIPTION AND USABLE ON CODES(UOC)	(6) QTY
GROUP 0401					
FIG.C-7 LATCH ASSEMBLY 12598168					
1	PAOZZ	96906	MS16562-129	PIN, SPRING.....	2
2	PAOZZ	19204	11010010	LEVER, LOCK-RELEASE BAYONET RH . . . . .	1
3	PAOZZ	19204	11010011	LEVER, LOCK-RELEASE BAYONET LH . . . . .	1
4	PAOZZ	19205	7160949	SPRING, HELICAL, COMP COMPRESSION . . . . .	1
5	XAOZZ	19200	12598167	LATCH, PLATE . . . . .	1
				UOC :AE2	

END OF FIGURE

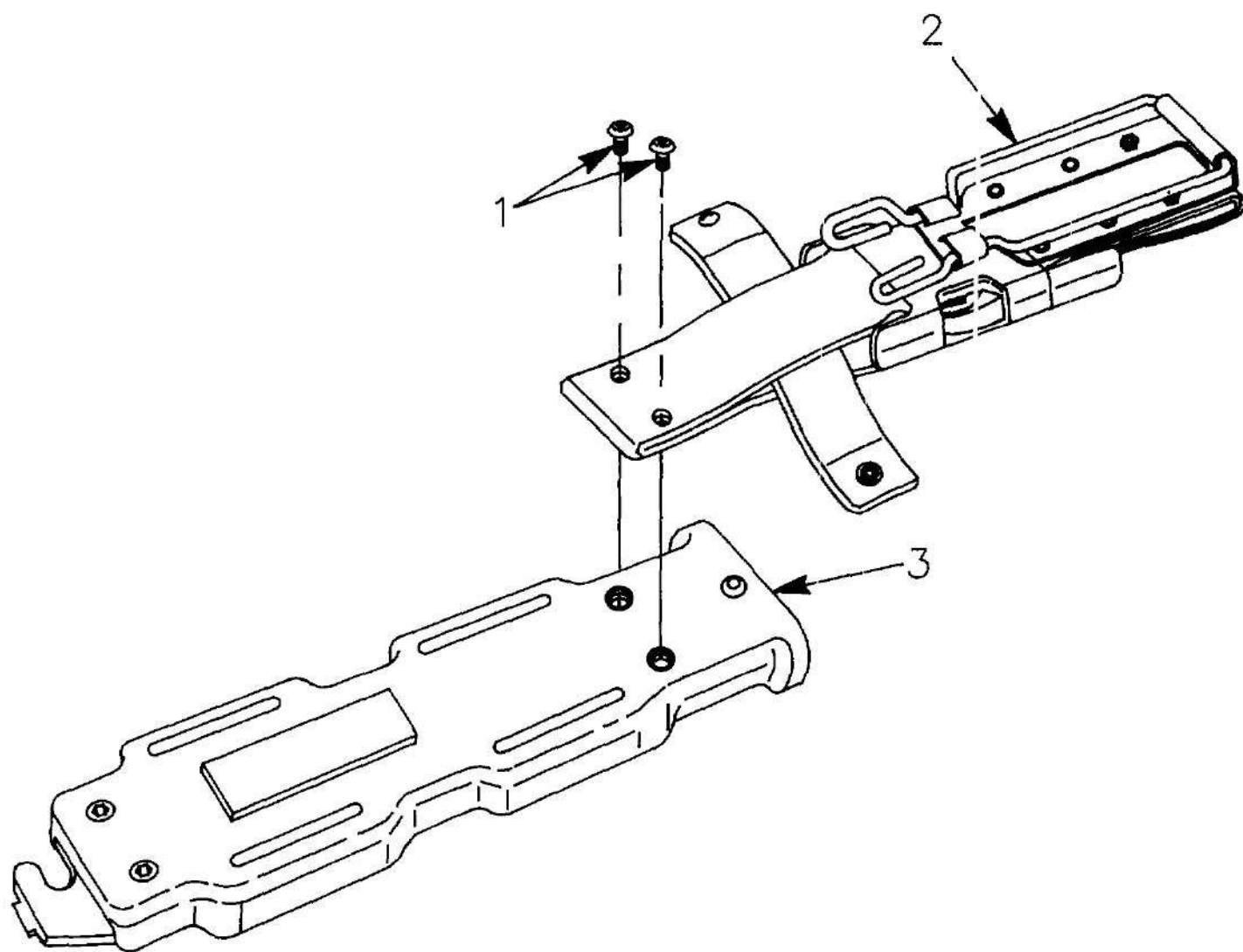

FIG. C-8 SCABBARD, BAYONET-KNIFE M9 12011862

(1) ITEM NO	(2) SMR CODE	(3) CAGEC	(4) PART NUMBER	(5) DESCRIPTION AND USABLE ON CODES (UOC)	(6) QTY
GROUP 05					
FIG.C-8 SCABBARD, BAYONET-KNIFE, M9 12011862					
1	PAOZZ	80204	ANSI B18.3 (.190 24 X .44)	SCREW,CAP, SOCKET HE.....	2
2	A0000	19200	12598193	ATTACHING ASSEMBLY.....	1
3	XAOFF	19200	12598184	SCABBARD,BODY ASSY ASSEMBLY.....	1
				UOC : AE2	

END OF FIGURE

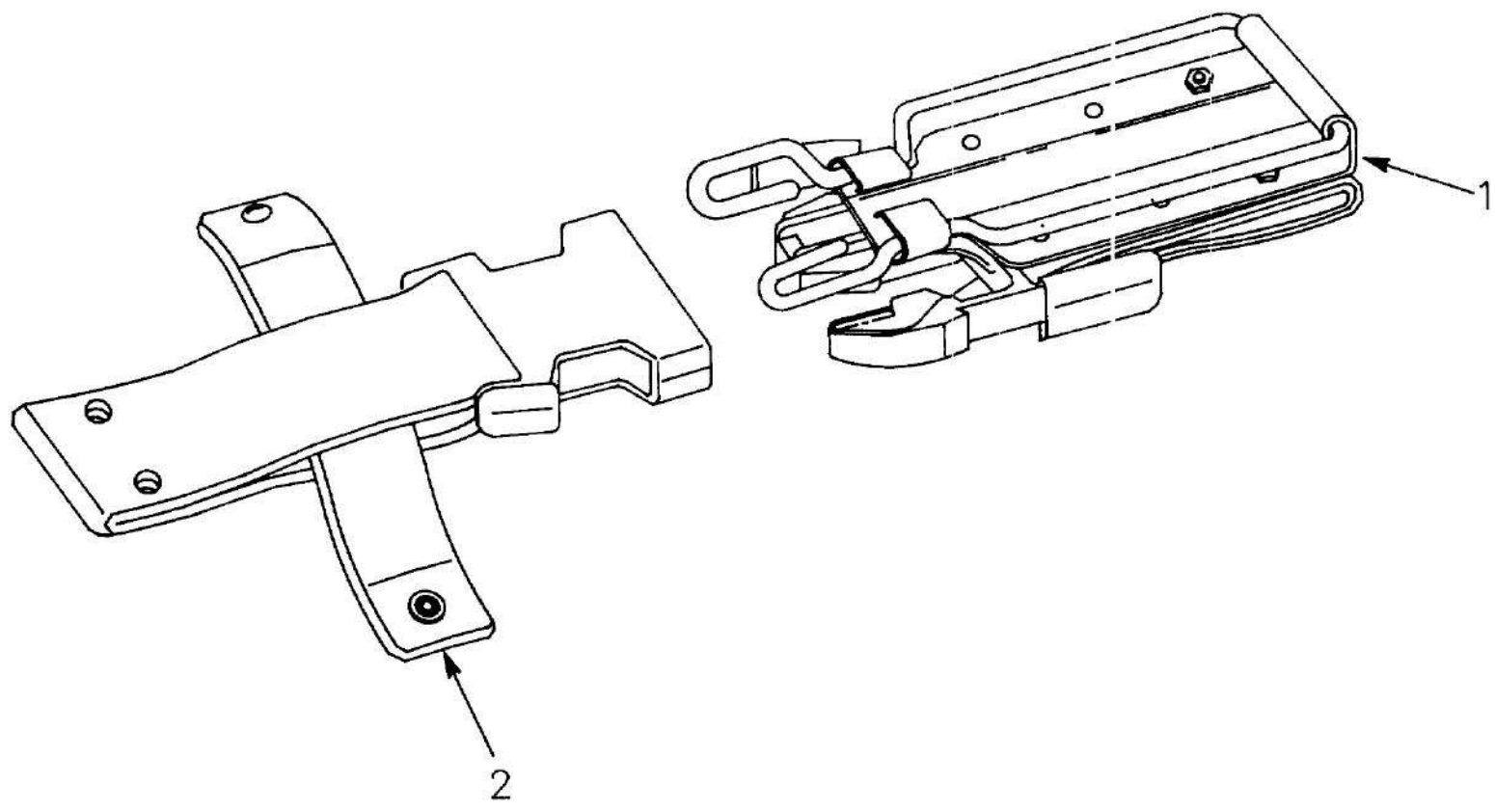

FIG. C-9 ATTACHING ASSEMBLY 12598193

(1) ITEM NO	(2) SMR CODE	(3) CAGEC	(4) PART NUMBER	(5) DESCRIPTION AND USABLE ON CODES(UOC)	(6) QTY
GROUP 0501					
FIG. C-9 ATTACHING ASSEMBLY 12598193					
1	PAOZZ	19200	12598195	ATTACHING ASSEMBLY, LCAD BEARING END.....	1
2	PAOZZ	19200	12598189	UOC : AE2 ATTACHING ASSY ASSEMBLY SCABBARD END..... UOC:AE2	1

END OF FIGURE

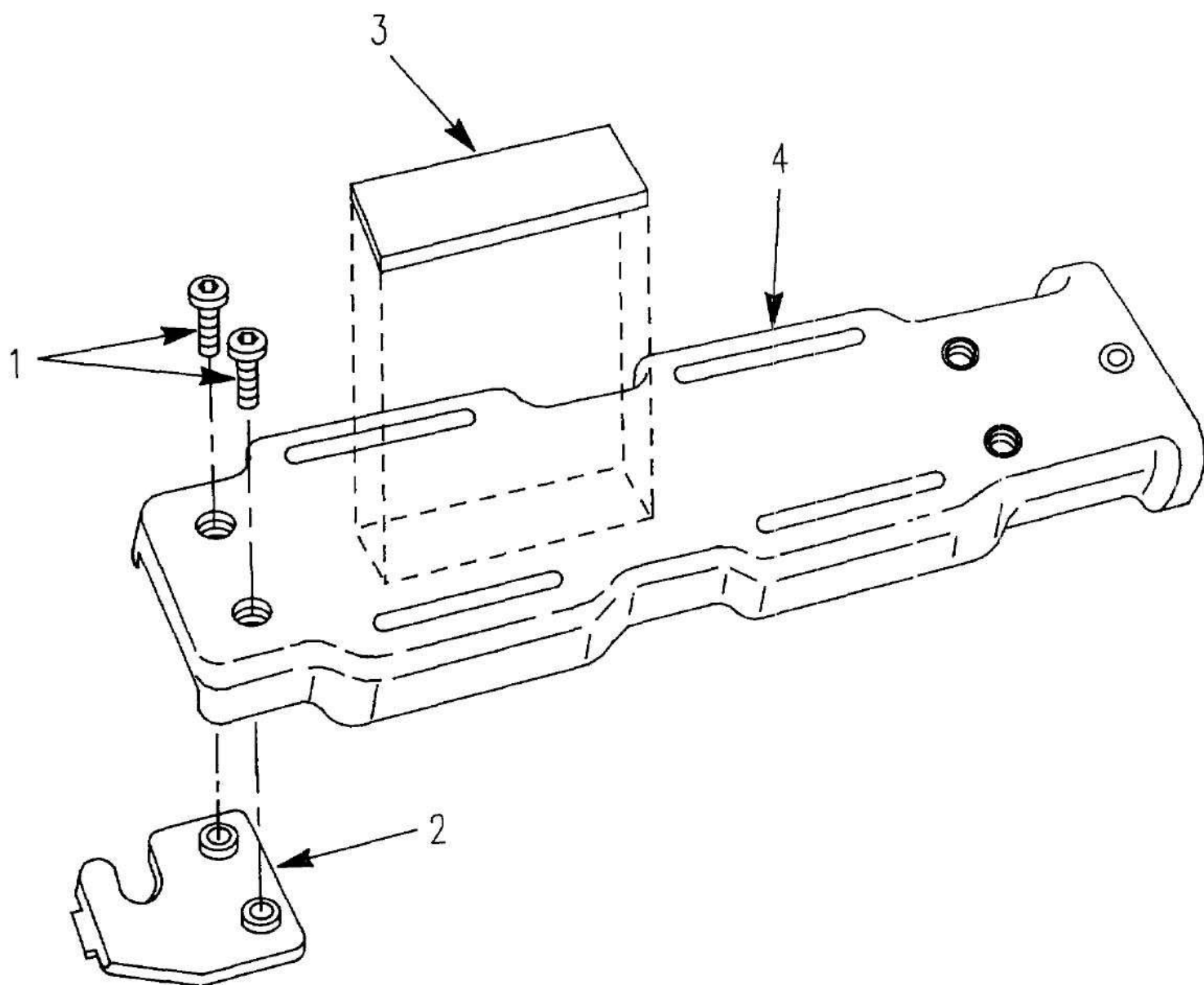

FIG. C-10 SCABBARD, BODY ASSEMBLY 12598184

(1) ITEM NO	(2) SMR CODE	(3) CAGEC	(4) PART NUMBER	(5) DESCRIPTION AND USABLE (N CODES(UOC)	(6) QTY
GROUP 0502					
FIG.C-10 SCABBARD, BODY ASSEMBLY 12598184					
1	PAOZZ	80204	ANSI B18.3 (.190 32 X .69)	SCREW,CAP, SOCKET HE HEAD . . . . .	2
2	PAFZZ	19200	12598182	CUTTER ASSY ASSEMBLY . . . . .	1
3	PAOZZ	19200	12598183	STONE, SHARPENING . . . . .	1
4	XAOZZ	19200	12598179	BODY, ASSY, SCABBAR D . . . . .	1
				UOC : AE2	
				UOC : AE2	
				UOC : AE2	

END OF FIGURE

## SECTION IV

## CROSS-REFERENCE INDEXES

## NATIONAL STOCK NUMBER INDEX

STOCK NUMBER	FIG.	ITEM	STOCK NUMBER	FIG.	ITEM
1005-00-051-3607	C-3	3			
1005-00-051-3608	C-3	4			
5305-00-051-3609	C-2	1			
	C-3	1			
5340-00-051-3899	C-4	3			
	C-7	2			
5340-00-051-3901	C-4	2			
	C-7	3			
5315-00-058-6077	C-2	4			
	C-4	1			
5315-00-058-6081	C-7	1			
1095-00-073-9238	C-1	2			
1095-00-223-7164	C-1	3			
1005-00-300-5378	C-5	1			
5360-00-333-3575	C-2	6			
5305-01-305-6170	C-10	1			
5305-01-351-4305	C-8	1			
1005-00-333-3577	C-2	3			
1005-00-333-3578	C-2	2			
5310-00-579-0079	C-3	2			
5360-00-716-0949	C-4	4			
	C-7	4			
1095-00-722-3097	C-1	1			
5345-01-275-5395	C-10	3			
1005-01-275-5397	C-10	2			
5340-01-275-5398	C-9	2			
5110-01-277-5767	C-6	3			
5305-01-278-1150	C-6	1			
1005-01-278-1174	C-9	1			
NPN	C-5	2			

## CROSS-REFERENCE INDEXES

## PART NUMBER INDEX

CAGEC	PART NUMBER	STOCK NUMBER	FIG.	ITEM
80204	ANSI B18.3 (.190 24 X .44)	5305-01-351-4305	C-8	1
80204	ANSI B18.3 (.190 32 X .69)	5305-01-305-6170	C-10	1
96906	MS16562-125	5315-00-058-6077	C-2 C-4	4 1
96906	MS16562-129	5315-00-058-6081	C-7	1
96906	MS35333-37	5310-00-579-0079	C-3	2
19204	11010010	5340-00-051-3899	C-4 C-7	3 2
19204	11010011	5340-00-051-3901	C-4 C-7	2 3
19204	11010066		C-4	5
19204	11010067		C-3	5
19204	11010068	1005-00-051-3607	C-3	3
19204	11010069	1005-00-051-3608	C-3	4
19204	11010077	1095-00-073-9238	C-1	2
19204	11010078	5305-00-051-3609	C-2 C-3	1 1
19200	12011861		C-1	4
19200	12011862		C-1	5
19200	12598166		C-6	4
19200	12598167		C-7	5
19200	12598168		C-6	2
19200	12598170	5110-01-277-5767	C-6	3
19200	12598171	5305-01-278-1150	C-6	1
19200	12598179		C-10	4
19200	12598182	1005-01-275-5397	C-10	2
19200	12598183	5345-01-275-5395	C-10	3
19200	12598184		C-8	3
19200	12598189	5340-01-275-5398	C-9	2
19200	12598193		C-8	2
19200	12598195	1005-01-278-1174	C-9	1
19205	7160949	5360-00-716-0949	C-4 C-7	4 4
19204	7267136-2	1005-00-300-5378	C-5	1
19204	7267616	1095-00-722-3097	C-1	1
19205	7267645	5360-00-333-3575	C-2	6
19204	7267648		C-2	5
19205	7267649		C-2	7
19204	7267652	1005-00-333-3577	C-2	3
19204	7267653	1005-00-333-3578	C-2	2
19204	8448476	1095-00-223-7164	C-1	3
NPN			C-5	2

## CROSS-REFERENCE INDEXES

## FIGURE AND ITEM NUMBER INDEX

FIG.		ITEM	CAGEC	PART NUMBER
C-1	1	1095-00-722-3097	19204	7267616
C-1	2	1095-00-073-9238	19204	11010077
C-1	3	1095-00-223-7164	19204	8448476
C-1	4		19200	12011861
C-1	5		19200	12011862
C-2	1	5305-00-051-3609	19204	11010078
C-2	2	1005-00-333-3578	19204	7267653
C-2	3	1005-00-333-3577	19204	7267652
C-2	4	5315-00-058-6077	96906	MS16562-125
C-2	5		19204	7267648
C-2	6	5360-00-333-3575	19205	7267645
C-2	7		19205	7267649
C-3	1	5305-00-051-3609	19204	11010078
C-3	2	5310-00-579-0079	96906	MS35333-37
C-3	3	1005-00-051-3607	19204	11010068
C-3	4	1005-00-051-3608	19204	11010069
C-3	5		19204	11010067
C-4	1	5315-00-058-6077	96906	MS16562-125
C-4	2	5340-00-051-3901	19204	11010011
C-4	3	5340-00-051-3899	19204	11010010
C-4	4	5360-00-716-0949	19205	7160949
C-4	5		19204	11010066
C-5	1	1005-00-300-5378	19204	7267136-2
C-5	2			NPN
C-6	1	5305-01-278-1150	19200	12598171
C-6	2		19200	12598168
C-6	3	5110-01-277-5767	19200	12598170
C-6	4		19200	12598166
C-7	1	5315-00-058-6081	96906	MS16562-129
C-7	2	5340-00-051-3899	19204	11010010
C-7	3	5340-00-051-3901	19204	11010011
C-7	4	5360-00-716-0949	19205	7160949
C-7	5		19200	12598167
C-8	1	5305-01-351-4305	80204	ANSI B18.3 (.190 24 X .44)
C-8	2		19200	12598193
C-8	3		19200	12598184
C-9	1	1005-01-278-1174	19200	12598195
C-9	2	5340-01-275-5398	19200	12598189
C-10	1	5305-01-305-6170	80204	ANSI B18.3 (.190 32 X .69)
C-10	2	1005-01-275-5397	19200	12598182
C-10	3	5345-01-275-5395	19200	12598183
C-10	4		19200	12598179

## APPENDIX D EXPENDABLE/DURABLE SUPPLIES AND MATERIALS LIST

## Section 1. INTRODUCTION

## D-1. SCOPE.

This appendix lists expendable/durable supplies and materials you will need to operate and maintain the M6 bayonet-knife with scabbard, the M7 bayonet-knife with scabbard and the M9 Multi Purpose Bayonet System, This listing is for informational purposes only and is not authority to requisition the listed items. These items are authorized to you by CTA 50-970, Expendable\Durable Items (Except Medical, Class V, Repair Parts, and Heraldic Items), or CTA 8-100, Army Medical Department Expendable/Durable Items.

## D-2. EXPLANATION OF COLUMNS.

- a. Column 1 -Item Number. This number is assigned to the entry in the listing and is referenced in the narrative instructions to identify the material (e.g., "Use cleaning compound, 5, app D.").
- b. Column 2-Level. This column identifies the lowest level of maintenance that requires the listed item.
  - o. . . . . Organizational Maintenance
- c. Column 3-National Stock Number This is the National stock number assigned to the item; use it to request or requisition the item.
- d. Column 4-description. Indicates the Federal item name and, if required, a description to identify the item. The last line for each item indicates the Contractor and Governmnet Entity Code (CAGEC) in parentheses followed by the part number.
- e. Column 5-Unit of Measure (U/M). Indicates the measure used in performing, the actual maintenance function. This measure is expressed by a two-character alphabetical abbreviation (e.g., ea, in., pr). If the unit of measure differs from the unit of issue, requisition the lowest unit of issue that will satisfy your requirements.

SECTION II. EXPENDABLE SUPPLIES AND MATERIALS LIST

(1)	(2)	(3)	(4)	(5)
Item Number	Level	Number	Description	U/M
1	0	1005-00-242-5687	BOTTLE ASSEMBLY, CYLINDRICAL (19204) 8448444	EA
2	0	7920-00-205-2401	BRUSH, CLEANING, TOOLS AND PARTS (96906) MS 16746-29	EA
3	0	9150-01-054-6453	CLEANER, LUBRICANT AND PRESERVATIVE, (CLP) 1-PT (0.47-1) TRIGGER SPRAYER (81349) MIL-L-63460	PT
4	0	5350-00-221-0872	CLOTH, ABRASIVE, CROCUS CLOTH, JEAN CLOTH BACKING 50-SH PG (58536) A-A-1206	SH
5	0	6850-00-281-1985	DRY CLEANING SOLVENT, (SD) 1-GAL. (3.79-1) CN (58536) A-A-711	GL
6	0	8010-00-297-0560	ENAMEL, OLIVE DRAB NO. 3407 1-GAL. (3.79-1) CN (81349) MIL-E-5556	GL
7	0	8415-00-823-7457	GLOVES, CHEMICAL AND TYPE 3 SOLVENT RESISTANT, SIZE 11 (81348) ZZ-G-381	PR
8	0	9150-01-260-2534	LUBRICANT, SOLID FILM: 16-OZ (0.47-1) SPRAY CN (81349) MIL-L-23398	OZ
9	C	9150-00-292-9689	LUBRICATING OIL, WEAPONS (LAW) (81349) MIL-L-14107 1-QT (0.95-1) CAN	QT
10			LUBRICATING OIL, WEAPONS (LSA) SEMIFLUID (81349) MIL-L-46000	
	C	9150-00-935-6597	2-OZ (59.15-ML) PLASTIC BTL	OZ
	C	9150-00-889-3522	4-OZ. (118.30-Ml) PLASTIC BTL	OZ
	O	9150-00-687-4241	1-QT (0.95-1) CAN	QT
	O	9150-00-753-4686	1-GAL (3.79-1) CAN	GL

(1)	(2)	(3)	(4)	(5)
Item Number		Level	Description	U/M
11	O	4940-00-795-3595	PAN, WASH (94453) 1211	EA
12	C	7920-00-205-1711	RAG, WIPING: COTTON 50-LB (22.68-KG) BE. (58536) AA531	LB
13	O	8040-00-851-0211	SILICONE ADHESIVE SEAL (8 OZ TUBE) (81349) MIL-A-46106, TYPE I OZ	

ALPHABETICAL INDEX

Subject	Page
C	
Clean/lubricate (See individual assembly.)	
Common tools and equipment . . . . .	.2-1
D	
Destruction of Army materiel to prevent enemy use . . . . .	1-1
Differences between models. . . . .	.1-2
Disassembly (See individual assembly.)	
E	
Expendable/durable supplies and materials list . . . . .	D-1
Explanation of columns . . . . .	D-1
Scope. . . . .	D-1
I	
Inspection (See individual assembly.)	
M	
Maintenance allocation chart . . . . .	B-1
Explanation of columns in the MAC, section II . . . . .	B-2
Explanation of columns in tool and test equipment requirements, section III . . . . .	B-4
General. . . . .	B-1
Maintenance functions . . . . .	B-1
Maintenance forms, records, and reports . . . . .	1-1
Model numbers and equipment names . . . . .	1-1
M6 Bayonet-knife:	
Clean/lubricate . . . . .	.2-15
Disassembly . . . . .	.2-12
Inspection/repair . . . . .	.2-13,
	3-1
PMCS . . . . .	2-6
Reassembly. . . . .	2-16
Service upon receipt . . . . .	.. 2-2

Subject	Page
M	
M7 Bayonet-knife:	
Clean/lubricate. . . . .	.2-15
Disassembly. . . . .	.2-12
Inspection/repair. . . . .	.2-13
pmcs . . . . .	.2-6
Reassembly. . . . .	.2-16
Service upon receipt . . . . .	.2-2
M7 blade assembly:	
Clean/lubricate. . . . .	.2-19
Disassembly. . . . .	.2-17
Inspection/repair. . . . .	.2-18, 3-4
Reassembly. . . . .	.2-20
M9 Multipurpose Bayonet System:	
Clean/lubricate. . . . .	.2-27, 3-7
Disassembly. . . . .	.2-23
Grinding. . . . .	.3-7
Inspection/repair. . . . .	.2-24
PMCS . . . . .	.2-9
Reassembly. . . . .	.2-28
Service upon receipt. . . . .	.2-3
M9 Multipurpose Bayonet System Latch Assembly:	
Clean/lubricate. . . . .	.2-31
Disassembly. . . . .	.2-29
Inspection/repair. . . . .	.2-30
Reassembly. . . . .	.2-31
M9 Multipurpose Bayonet System Scabbard:	
Clean/lubricate. . . . .	2-35
Disassembly. . . . .	2-32
Inspection/repair. . . . .	2-33
PMCS . . . . .	.2-10
Reassembly. . . . .	2-35
M9 Multipurpose Bayonet System Scabbard Body Assembly:	
Clean/lubricate. . . . .	2-39, 3-9
Disassembly. . . . .	2-39, 3-9
Inspection. . . . .	.2-37, 3-8
Reassembly. . . . .	.2-40, 3-9

Subject	Page
MIO bayonet-knife scabbard:	
Inspection/repair. . . . .	.2-21
PMCS . . . . .	.2-8
Service upon receipt. . . . .	.2-2

N

National stock number and part number index . . . . .	C-7
---	-----

O

Organizational and direct support maintenance repair parts and special tools list: . . . . .	C-1
Abbreviations. . . . .	.C-7
Explanation of columns (sections II and III) . . . . .	.C-1
Explanation of columns (section IV) . . . . .	.C-6
General . . . . .	.C-1
How to locate repair parts . . . . .	C-7
Scope. . . . .	C-1
Special information. . . . .	C-7

P

Preparation for storage or shipment . . . . .	1-1
Preventive maintenance checks and services . . . . .	2-5
Purpose of equipment. . . , . . . . .	.1-1

R

Reassembly (See individual assembly.)	
References . . . . .	A-1
Repair (See individual assembly.)	
Repair parts. . . . .	2-1
Reporting equipment improvement recommendations (EIR) . . . . .	1-1
Reporting errors and recommending improvements . . . . .	i
RPSTL (See organizational and direct support maintenance repair parts and special tools list.)	

S

Scope. . . . .	.1-1
Service upon receipt of materiel . . . . .	.2-1
Special tools, TMDE, and support equipment . . . . .	2-1

Subject

Page

T

Table of contents . . . . . i

Type of manual . . . . . 1-1

W

Warning page . . . . . a

**By Order of the Secretary of the Army:**

**GORDON R. SULLIVAN**  
*General, United States Army*  
*Chief of Staff*

Official:

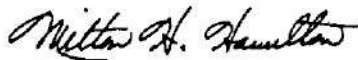

MILTON H. HAMILTON  
*Administrative Assistant to the*  
*Secretary of the Army*

03211

DISTRIBUTION:

To be distributed in accordance with DA Form 12-40-E, Block 0201,  
requirements for TM 9-1005-237-23&P.





THEN... JOT DOWN THE DOPE ABOUT IT ON THIS FORM. CAREFULLY TEAR IT OUT. FOLD IT AND DROP IT IN THE MAIL!

# SOMETHING WRONG WITH THIS PUBLICATION?

FROM: (PRINT YOUR UNIT'S COMPLETE ADDRESS)

*Your Mailing Address*

DATE SENT

PUBLICATION NUMBER

TM 9-1005-237-23&P

PUBLICATION DATE

11 Jan 93

PUBLICATION TITLE (Org and DS Maint Man. w/RPSTL for M6 and M7 Bayonets and M10 Scabbard and M9

BE EXACT... PIN-POINT WHERE IT IS

PAGE NO	PARA-GRAPH	FIGURE NO	TABLE NO
A-1			
D-2			

IN THIS SPACE TELL WHAT IS WRONG AND WHAT SHOULD BE DONE ABOUT IT:

*There is no -10 manual for bayonets. Suggest there should be one.*

*ITEM 9, NSN should be 9150-01-292-9689,*

SAMPLE

PRINTED NAME, GRADE OR TITLE AND TELEPHONE NUMBER

SIGN HERE

Your name

FILL IN YOUR  
UNIT'S ADDRESS



DEPARTMENT OF THE ARMY



OFFICIAL BUSINESS

NO POSTAGE  
NECESSARY  
IF MAILED  
IN THE  
UNITED STATES

**BUSINESS REPLY MAIL**

FIRST CLASS

PERMIT NO. 82

ROCK ISLAND IL

POSTAGE WILL BE PAID BY ROCK ISLAND ARSENAL

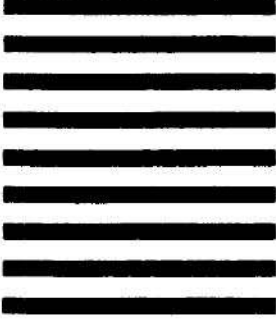

**COMMANDER  
U.S. ARMY ARMAMENT, MUNITIONS  
AND CHEMICAL COMMAND  
ATTN AMSMC-MAS  
ROCK ISLAND IL 61201-9948**

TEAR ALONG PERFORATED LINE



TEAR ALONG PERFORATED LINE

FILL IN YOUR  
UNIT'S ADDRESS



DEPARTMENT OF THE ARMY



OFFICIAL BUSINESS

NO POSTAGE  
NECESSARY  
IF MAILED  
IN THE  
UNITED STATES

**BUSINESS REPLY MAIL**

FIRST CLASS

PERMIT NO. 82

ROCK ISLAND IL

POSTAGE WILL BE PAID BY ROCK ISLAND ARSENAL



COMMANDER  
U.S. ARMY ARMAMENT, MUNITIONS  
AND CHEMICAL COMMAND  
ATTN AMSMC-MAS  
ROCK ISLAND IL 61201-9948

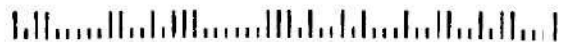



# THE METRIC SYSTEM AND EQUIVALENTS

## LINEAR MEASURE

- 1 Centimeter= 10 Millimeters= 0.01 Meter= 0.3937 Inch
- 1 Decimeter= 10 Centimeters = 3.94 Inches
- 1 Meter= 10 Decimeters = 100 Centimeters  
= 1000 Millimeters= 39.37 Inches
- 1 Dekameter = 10 Meters= 32.8 Feet
- 1 Hectometer = 10 Dekameters = 328.08 Feet
- 1 Kilometer= 10 Hectometers = 1000 Meters  
= 0.621 Mile = 3,280.8 Feet
- Millimeters = Inches times 25.4
- Inches = Millimeters divided by 25.4

## WEIGHTS

- 1 Centigram = 10 Milligrams = 0.154 Grain
- 1 Decigram = 10 Centigrams = 1.543 Grains
- 1 Gram= 0.001 Kilogram = 10 Decigrams  
= 1000 Milligrams= 0.035 Ounce
- 1 Dekagram = 10 Grams = 0.353 Ounce
- 1 Hectogram = 10 Dekagrams = 3.527 Ounces
- 1 Kilogram = 10 Hectograms = 1000 Grams = 2.205 Pounds
- 1 Quintal = 100 Kilograms= 220.46 Pounds
- 1 Metric Ton = 10 Quintals = 1000 Kilograms = 1.1 Short Tons

## LIQUID MEASURE

- 1 Milliliter = 0.001 Liter= 0.034 Fluid Ounce
- 1 Centiliter = 10 Milliliters = 0.34 Fluid Ounce
- 1 Deciliter = 10 Centiliters = 3.38 Fluid Ounces
- 1 Liter = 10 Deciliters= 1000 Milliliters= 33.82 Fluid Ounces
- 1 Dekaliter = 10 Liters= 2.64 Gallons
- 1 Hectoliter = 10 Dekaliters = 26.42 Gallons
- 1 Kiloliter = 10 Hectoliters = 264.18 Gallons

## SQUARE MEASURE

- 1 Sq Centimeter= 100 Sq Millimeters = 0.155 Sq Inch
- 1 Sq Decimeter= 100 Sq Centimeters = 15.5 Sq Inches
- 1 Sq Meter (Centare) = 10 Sq Decimeters  
= 10,000 Sq Centimeters = 10.764 Sq Feet
- 1 Sq Dekameter (Are) = 100 Sq Meters = 1,076.4 Sq Feet
- 1 Sq Hectometer (Hectare) = 100 Sq Dekameters = 2.471 Acres
- 1 Sq Kilometer= 100 Sq Hectometers = 1,000,000 Sq Meters  
= 0.386 Sq Mile

## CUBIC MEASURE

- 1 Cu Centimeter= 1000 Cu Millimeters= 0.061 Cu Inch
- 1 Cu Decimeter= 1000 Cu Centimeters = 61.02 Cu Inches
- 1 Cu Meter = 1000 Cu Decimeters = 1,000,000 Cu Centimeters  
= 35.31 Cu Feet

## TEMPERATURE

- $5/9 (^{\circ}\text{F} - 32^{\circ}) = ^{\circ}\text{C}$
- $9/5 (^{\circ}\text{C} + 32^{\circ}) = ^{\circ}\text{F}$
- 35° Fahrenheit is equivalent to -37° Celsius
- 0° Fahrenheit is equivalent to -18° Celsius
- 32° Fahrenheit is equivalent to 0° Celsius
- 90° Fahrenheit is equivalent to 32.2° Celsius
- 100° Fahrenheit is equivalent to 38° Celsius
- 212° Fahrenheit is equivalent to 100° Celsius

## APPROXIMATE CONVERSION FACTORS

<u>TO CHANGE.</u>	<u>TO</u>	<u>MULTIPLY BY</u>	<u>TO CHANGE</u>	<u>TO</u>	<u>MULTIPLY BY</u>
Inches	Centimeters	2.540	Meters	Feet	3.280
Feet	Meters	0.305	Meters	Yards	1.094
Yards	Meters	0.914	Kilometers	Miles	0.621
Miles	Kilometers	1.609	Square Centimeters	Square Inches	0.155
Square Inches	Square Centimeters	6.451	Square Meters	Square Feet	10.764
Square Feet	Square Meters	0.093	Square Meters	Square Yards	1.196
Square Yards	Square Meters	0.836	Square Kilometers	Square Miles	0.386
Square Miles	Square Kilometers	2.590	Square Hectometers	Acres	2.471
Acres	Square Hectometers	0.405	Cubic Meters	Cubic Feet	35.315
Cubic Feet	Cubic Meters	0.028	Cubic Meters	Cubic Yards	1.308
Cubic Yards	Cubic Meters	0.765	Milliliters	Fluid Ounces	0.034
Fluid Ounces	Milliliters	29.573	Liters	Pints	2.113
Pints	Liters	0.473	Liters	Quarts	1.057
Quarts	Liters	0.946	Liters	Gallons	0.264
Gallons	Liters	3.785	Grams	Ounces	0.035
Ounces	Grams	28.349	Kilograms	Pounds	2.205
Pounds	Kilograms	0.454	Metric Tons	Short Tons	1.102
Short Tons	Metric Tons	0.907	Newton-Meters	Pound-Feet	0.738
Pound-Feet	Newton-Meters	1.356	Kilopascals	Pounds per Square Inch	0.145
Pounds-Inches	Newton-Meters	0.11375	Kilometers per Liter	Miles per Gallon	2.354
Pounds per Square Inch	Kilopascals	6.895	Kilometers per Hour	Miles per Hour	0.621
Ounce-inches	Newton-Meters	0.007062	°Fahrenheit	°Celsius	$^{\circ}\text{C} = (^{\circ}\text{F}-32)\times 5/9$
Miles per Gallon	Kilometers per Liter	0.425	°Celsius	°Fahrenheit	$^{\circ}\text{F} = (9/5\times^{\circ}\text{C})+32$
Miles per Hour	Kilometers per Hour	1.609			
Centimeters	Inches	0.394			

**PIN : 060933-000**