

CFP 317(18)

B-GL-317-018/PT-001

INTERIM 1



**WEAPONS
VOLUME 18
THE RIFLE 5.56 mm C7
AND
CARBINE 5.56 mm C8**

Digitized by:

CFP 317(18)

B-GL-317-018/PT-001

INTERIM 1



**WEAPONS
VOLUME 18
THE RIFLE 5.56 mm C7
AND
CARBINE 5.56 mm C8**

OPI: SSO INF/FMC HQ

21 FEB 86

WARNING

ALTHOUGH NOT CLASSIFIED THIS PUBLICATION OR PART OF IT MAY BE EXEMPT FROM DISCLOSURE TO THE PUBLIC UNDER THE ACCESS TO INFORMATION ACT. ALL ELEMENTS OF INFORMATION CONTAINED THEREIN MUST BE CLOSELY SCRUTINIZED TO ASCERTAIN WHETHER OR NOT THE PUBLICATION OR PART OF IT MAY BE RELEASED.

LIST OF EFFECTIVE PAGES

1. Insert latest changed pages; dispose of superseded pages in accordance with applicable orders.

Note: On a changed page, the portion of the text affected by the latest change is indicated by a vertical line in the margin of the page. Changes to illustrations are indicated by miniature pointing hands or black vertical lines.

2. This consists of the following:

Page No.	Change No.
Cover	0
Title Page	0
A Page	0
Covering Letter	0
i to xiii	0
1-1 to 1-6	0
2-1 to 2-97	0
3-1 to 3-25	0
4-1 to 4-17	0
5-1 to 5-2	0
5A-1 to 5B10-1	0
6-1 to 6-2	0
6A-1 to 6E1-2	0
7-1	0
7A-1 to 7B-1	0

Zero in Change No. Column indicates an original page.





ARMY DOCTRINE AND TACTICS BOARD
CONSEIL DE DOCTRINE ET DE TACTIQUE DE L'ARMÉE

FMC 2910-CFP 317(18) (CD Coord)

Mobile Command Headquarters
St-Hubert, Quebec
J3Y 5T5

21 February 1986

Distribution List

CFP 317(18), INTERIM 1
THE RIFLE 5.56 MM C7 AND CARBINE 5.56 mm C8

1. This manual is published as the primary reference for the C7 Rifle and C8 Carbine. It is written in lesson plan format to simplify instruction and understanding which will be particularly important during mobilization.
2. CFP 317(18) Interim 1 should be read in conjunction with its companion manual CFP 317(19), **The Light Machine-Gun 5.56 mm, C9.**
3. The Interim French version will be distributed as soon as translation is completed.
4. Suggestions for change should be forwarded to Mobile Command Headquarters, Attention: SSO Infantry.

D.I. McNabb
Colonel
Chairman

Army Doctrine and Tactics Board

DISTRIBUTION LIST (NOTAL)

WARNING

MISUSE OF WEAPONS, AMMUNITION AND EXPLOSIVES

Purpose

1. This order outlines Canadian Forces Policy governing the use or misuse of weapons, ammunition and explosives.

Weapons

2. Firing or attempting to fire locally manufactured weapons, obsolete service or foreign weapons, or weapons used for display, ceremonial or trophy purposes in museums, messes, parade grounds, armouries or such like areas is prohibited except when specifically authorized by NDHQ.

3. Attention is also drawn to the following references which concern offences connected with the use or misuse of weapons:

- a. National Defence Act, Section 117;
- b. Criminal Code of Canada, Sections 82 to 106; and
- c. QR & O 103.59;

Ammunition and Explosives

4. Tampering with or use of service and commercial ammunition or explosives for other than their designed purpose is prohibited.

5. Except as prescribed in paragraph 6, the modification, breakdown or sectioning of live ammunition for experimental, instructional or any other purpose, or manufacture of explosives is forbidden; this prohibition includes:

- a. unauthorized interchange of fuzes or primers or both;
- b. experiments with blank ammunition to alter the powder charge or to introduce any other substance into the cartridge case or into the weapon with the approved cartridge;
- c. experiments involving the use of altered propelling charges or bursting charges with ammunition of any type;
- d. the use of any non-service or obsolete ammunition;
- e. the use of foreign ammunition other than that received through normal supply channels or supplied in accordance with NATO Standardization Agreements;

- f. the manufacture and use of locally fabricated explosive training devices, battle simulators, saluting charges, etc.
 - g. any alteration to the design of ammunition or explosive devices;
 - h. deviations from authorized drills for use of ammunition or explosive devices; and
 - j. rendering live ammunition inert for use as museum or instructional items.
6. The prohibition in paragraph 5 does not apply to:
- a. authorized experiments, modifications, etc. carried out by experimental, research, proof or inspection establishments;
 - b. authorized breakdown, modification, repairs, proof-testing, etc. carried out as normal functions of a Canadian Forces ammunition depot or base ammunition facility;
 - c. personnel employed at Canadian Forces School of Aerospace and Ordnance Engineering as instructors or trainees under supervision, when breaking down is carried out as part of a course training standard and in accordance with an approved course training plan;
 - d. the use for its designed role of commercial pattern ammunition, which is obtained by local purchase as specified in CFP 137 or as authorized by NDHQ in accordance with CFAO 36-19;
 - e. the use for its designed role of commercial pattern ammunition which is taken into service and catalogued;
 - f. hand-loading small arms ammunition in accordance with CFAO 50-18; or
 - g. other cases, when specifically authorized by NDHQ.

FOREWORD

1. B-GL-317-018/PT-001, CFP 317(18), Interim 1, The Rifle 5.56 mm C7 and Carbine 5.56 mm C8 is issued on the authority of the Chief of Defence Staff .
2. This publication is the basic reference for the employment of the C7 Rifle and C8 Carbine.
3. The range practices included in Chapter 5 will eventually be incorporated in CFP 318(6) Shoot to Live, Part One.
5. Comments and suggestions for changes should be forwarded through the usual channels to FMC HQ Attention: SSO Infantry.

TABLE OF CONTENTS

CHAPTER	SUBJECT MATTER	PAGE
1	AIM AND SCOPE	
	101 Aim	1-1
	102 Background	1-1
	103 Format	1-1
	104 Practice Periods	1-4
	105 Left Handed Firers	1-5
	106 Shoot-To-Live	1-6
	107 Classroom Drills	1-6
	108 Safety Precautions	1-6
2	LESSON PLANS - BASIC SKILLS	
	LESSON 1 - INTRODUCTION	2-1
	Aim - To teach the description, technical data and safety precautions.	
	LESSON 2 - STRIPPING, ASSEMBLING AND CLEANING	2-8
	Aim - To teach how to strip, assemble and clean the rifle.	
	LESSON 3 - AMMUNITION HANDLING, SIGHT ALTERATION, LOAD, PREPARE TO FIRE, UNLOAD AND MAKE SAFE	2-20
	Aim - To teach:	
	a. the care of ammunition and magazine filling;	
	b. sight alteration;	
	c. how to load, prepare to fire, make safe and unload; and	
	d. safety precautions with a magazine fitted.	
	LESSON 4 - HOLDING AND AIMING	2-26
	Aim - To teach how to hold the rifle correctly in the prone position and how to take a correct aim.	
	LESSON 5 - FIRING IN THE PRONE POSITION	2-36
	Aim - To teach how to fire the rifle in the prone position by combining the four marksmanship principles.	

TABLE OF CONTENTS

CHAPTER	SUBJECT MATTER	PAGE
2 (Cont)		
	LESSON 6 - FIRING DRILLS	2-40
	Aim - To teach: a. orders during firing; b. the alert position; c. types of fire; and d. rates of fire.	
	LESSON 7 - FIRING FROM OTHER POSITIONS	2-47
	Aim - To teach how to fire from the kneeling, sitting, standing and squatting positions, and the alert position as applied in each.	
	LESSON 8 - MECHANISM, IMMEDIATE ACTION AND POSSIBLE STOPPAGES	2-55
	Aim - To teach: a. how the rifle operates; b. the reason for stoppages; and c. the prevention and remedies for stoppages.	
	LESSON 9 - ALTERATION OF POINT OF AIM, WIND ALLOWANCE AND MISS DRILL	2-65
	Aim - To teach: a. how to correct errors by altering the point of aim; b. the allowance to make for different types of wind; and c. the correct drill to carry out on missing the target.	
	LESSON 10 - CLOSE QUARTER BATTLE	2-68
	Aim - To teach the methods of carrying the rifle and how to fire at close quarters.	
	LESSON 11 - FIRING AT CROSSING TARGETS	2-74
	Aim - To teach the allowances which have to be made for crossing targets and methods used to apply them.	

TABLE OF CONTENTS

CHAPTER	SUBJECT MATTER	PAGE
2 (Cont)		
	LESSON 12 - FIRING FROM COVER	2-78
	Aim - To teach how to handle and fire a rifle from behind cover.	
	LESSON 13 - BAYONET FIGHTING	2-85
	Aim - To teach how to attack and kill the enemy with the bayonet and methods of self-defence.	
	LESSON 14 - ANTI-AIRCRAFT DRILLS	2-93
	Aim - To teach how to fire at aircraft.	
3	PRACTICE PERIODS	
	PRACTICE 1 - LESSONS 1, 2 AND 3	3-1
	Aim - To practise:	
	a. stripping, assembling, knowledge of parts and magazine filling; and	
	b. load, prepare to fire, make safe, unload and safe handling.	
	PRACTICE 2 - LESSONS 4, 5 AND 6	3-5
	Aim - To practise:	
	a. timing, the prone position and hold, testing and adjusting the position, firing the shot and the follow through;	
	b. correcting errors by altering the sight or the point of aim, and the allowances to make for different types of wind; and	
	c. deliberate, rapid and snaphooting drills and the alert position.	
	PRACTICE 3 - LESSON 7	3-10
	Aim - To practise firing from the kneeling, sitting, squatting and standing positions.	

TABLE OF CONTENTS

CHAPTER	SUBJECT MATTER	PAGE
3 (Cont)		
	PRACTICE 4 - LESSONS 8 AND 9	3-14
	Aim - a. To confirm knowledge of the rifle mechanism, the Immediate Action (IA) and stoppages.	
	b. To practise correcting errors by altering the sight or the point of aim, and the allowances to make for different types of wind.	
	PRACTICE 5 - LESSONS 10 AND 12	3-18
	Aim - To practise:	
	a. methods of carrying and firing at close quarters, and	
	b. how to handle and fire from behind cover.	
	PRACTICE 6 - LESSON 13	3-22
	Aim - To practise bayonet fighting.	
4	INFORMATION FOR INSTRUCTORS	
	SECTION 1 - COACHING TECHNIQUES	
	401 General	4-1
	402 The Coach	4-1
	403 Theory of a Group	4-2
	404 Poor Shooting	4-3
	405 Coaching During Dry Practice	4-4
	406 Position and Holding	4-4
	407 Natural Alignment	4-5
	408 Aiming	4-5
	409 Shot Release and Follow Through	4-6
	410 Maintaining Interest	4-7
	411 Coaching During Grouping Practice	4-8
	412 Procedure for Coaching Before Firing	4-8
	413 Procedure for Coaching During Firing	4-8
	414 Procedures for Coaching After Firing	4-9
	415 Coaching During Application of Fire	4-10
	416 Aids to Observation	4-11
	417 Coaching During Rapid Practices	4-12
	418 Group Coach System	4-12
	419 Summary	4-12

TABLE OF CONTENTS

CHAPTER	SUBJECT MATTER	PAGE
4		
(Cont)		
	SECTION 2 - ZEROING	
	420 General	4-13
	SECTION 3 - EXAMINATION OF THE RIFLE	
	421 General	4-14
	422 Examination	4-14
	SECTION 4 - NIGHT FIRING	
	423 General	4-16
5	RANGE PRACTICES	
	SECTION 1 - GENERAL	
	501 Introduction	5-1
	502 Aim	5-1
	503 General	5-1
ANNEX	TITLE	PAGE
A	C7 RIFLE SUMMARY OF RANGE PRACTICES	5A-1
APPENDIX		
1	Grouping Prone Supported	5A1-1
2	Grouping Other Positions at 20 M	5A2-1
3	Grouping All Positions at 100 M	5A3-1
4	Zeroing at 100 M	5A4-1
5	Elementary Application	5A5-1
6	Advanced Application Rapid and Snapshooting	5A6-1
7	Elementary Application Bursts	5A7-1
8	Advanced Application Firing at Crossing Targets	5A8-1
9	Introduction to Night Shooting	5A9-1
10	Night Shooting with Illumination	5A10-1
ANNEX	TITLE	PAGE
B	C8 CARBINE SUMMARY OF RANGE PRACTICES	5B-1
APPENDIX		
1	Grouping Prone Supported	5B1-1
2	Grouping Other Positions at 20 M	5B2-1
3	Grouping all Positions at 100 M	5B3-1
4	Zeroing at 100 M	5B4-1
5	Elementary Application	5B5-1
6	Advanced Application Rapid and Snapshooting	5B6-1
7	Elementary Application Bursts	5B7-1
8	Advanced Application Firing at Crossing Targets	5B8-1
9	Introduction to Night Shooting	5B9-1
10	Night Shooting with Illumination	5B10-1

TABLE OF CONTENTS

6	TESTS AND STANDARDS	
	601 Introduction	6-1
	602 Handling Tests	6-1
	603 Grouping Standards	6-2
ANNEX	TITLE	PAGE
A	GROUPING STANDARDS	6A-1
B	HANDLING TESTS	6B-1
C	PERSONAL WEAPON TEST	6C-1
D	INFANTRY ANNUAL PERSONAL WEAPON TEST (NIGHT SUPPLEMENT)	6D-1
E	ALL ARMS AND SERVICES ALTERNATIVE PERSONAL WEAPON TEST	6E-1
7	METHODS OF DESTRUCTION	
	701 Methods of Destruction	7-1
	702 References and Standardization Agreements	7-1
ANNEX	TITLE	PAGE
A	METHODS OF DESTRUCTION	7A-1
B	REFERENCES AND STANDARDIZATION AGREEMENTS	7B-1

LIST FIGURES

FIGURE	TITLE	PAGE
1-1	C7 Rifle	1-2
1-2	C8 Carbine	1-3
2-1	Layout for Instruction	2-1
2-2	Bolt, Bolt Carrier and Firing Pin	2-8
2-3	Remove Bolt Carrier Assembly	2-8
2-4	Withdraw Retaining Pin	2-8
2-5	Remove Cam Pin	2-9
2-6	Proper Location of the Firing Pin Retaining Pin	2-9
2-7	Extractor Pin Removed	2-9
2-8	Extractor Removed	2-10
2-9	Receivers Separated	2-10
2-10	Depress Buffer Retainer	2-10
2-11	Buffer and Action Spring Removed	2-11
2-12	Cleaning Kit	2-11
2-13	General Purpose Sling	2-12
2-14	Magazine Charger	2-20
2-15	Front and Rear Sight	2-20
2-16	Standing Load Position	2-21
2-17	Prone Position	2-26
2-18	Modified Prone Position	2-26
2-19	Holding in the Prone Position	2-26
2-20	Correct Aim Picture	2-27

TABLE OF CONTENTS

FIGURE	TITLE	PAGE
2-21	Breath Restraint	2-36
2-22	Prone Alert Position	2-40
2-23	Kneeling Position	2-47
2-24	Kneeling-Alert Position	2-47
2-25	Sitting Position	2-48
2-26	Sitting Alert Position	2-48
2-27	Standing Position	2-49
2-28	Squatting Position	2-49
2-29	Firing	2-55
2-30	Bolt Locking and Unlocking	2-55
2-31	Extracting	2-56
2-32	Ejecting	2-56
2-33	Feeding	2-57
2-34	Chambering	2-57
2-35	Selector Lever Action	2-58
2-36	High Port	2-68
2-37	Alert Position	2-68
2-38	Cradle Carry	2-69
2-39	Low Port	2-69
2-40	Firing From a Trench	2-78
2-41	Firing Using a Post	2-78
2-42	Firing From a Corner	2-79
2-43	Firing Over Cover	2-79
2-44	On Guard	2-85
2-45	Thrust	2-85
2-46	Enemy on the Ground - On Guard	2-86
2-47	Enemy on the Ground - Thrust	2-86
2-48	Parry	2-87
2-49	Butt Stroke	2-87
2-50	Aircraft Action - Kneeling Position	2-93
3-1	Practice 1 Scoresheet	3-1
3-2	Practice 2 Scoresheet	3-6
3-3	Practice 3 Scoresheet	3-10
3-4	Practice 4 Scoresheet	3-11
3-5	Target Layout	3-18
3-6	Practice 5 Scoresheet	3-18
3-7	Practice 6 Scoresheet	3-22
4-1	Zero Location	4-14

CHAPTER 1

AIM AND SCOPE

101. AIM

This publication contains the information necessary to train soldiers in the handling, firing, employment and maintenance of the 5.56 mm C7 rifle and C8 carbine.

102. BACKGROUND

1. The C7 rifle and C8 carbine are adaptations of the M16A1E1 rifle developed by Colt Firearms of the United States. To select, and develop this weapon, military trials and engineering tests were conducted by a number of highly skilled Canadian personnel. These were the most extensive small arms' trials and tests ever conducted in Canada. Several modifications were made to the original weapon resulting in the current Canadian version.

103. FORMAT

1. The information in Chapters 2 and 3 is presented in lesson plan form. The manual is laid out as follows:
- a. Chapter 1 contains general information about the C7 rifle and C8 carbine and methods for teaching its use.
 - b. Chapter 2 contains the basic skills and the specific information required by soldiers to operate the weapons.
 - c. Chapter 3 consists of practice periods designed to further develop the skills and techniques learned in Chapter 2.
 - d. Chapter 4 contains information for instructors such as coaching techniques.
 - e. Chapter 5 contains the range practices and Methods of Destruction.

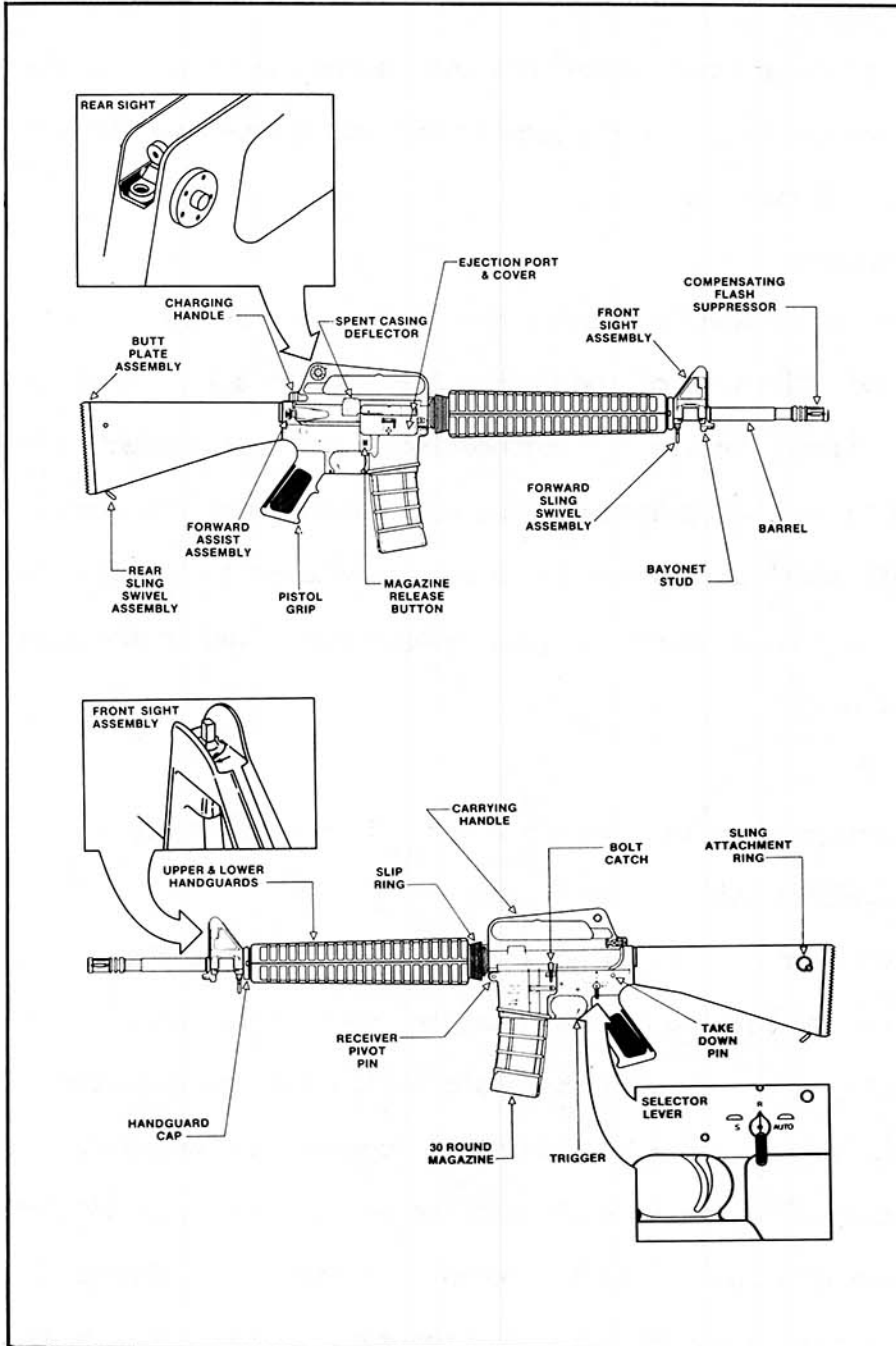

Figure 1-1 C7 Rifle

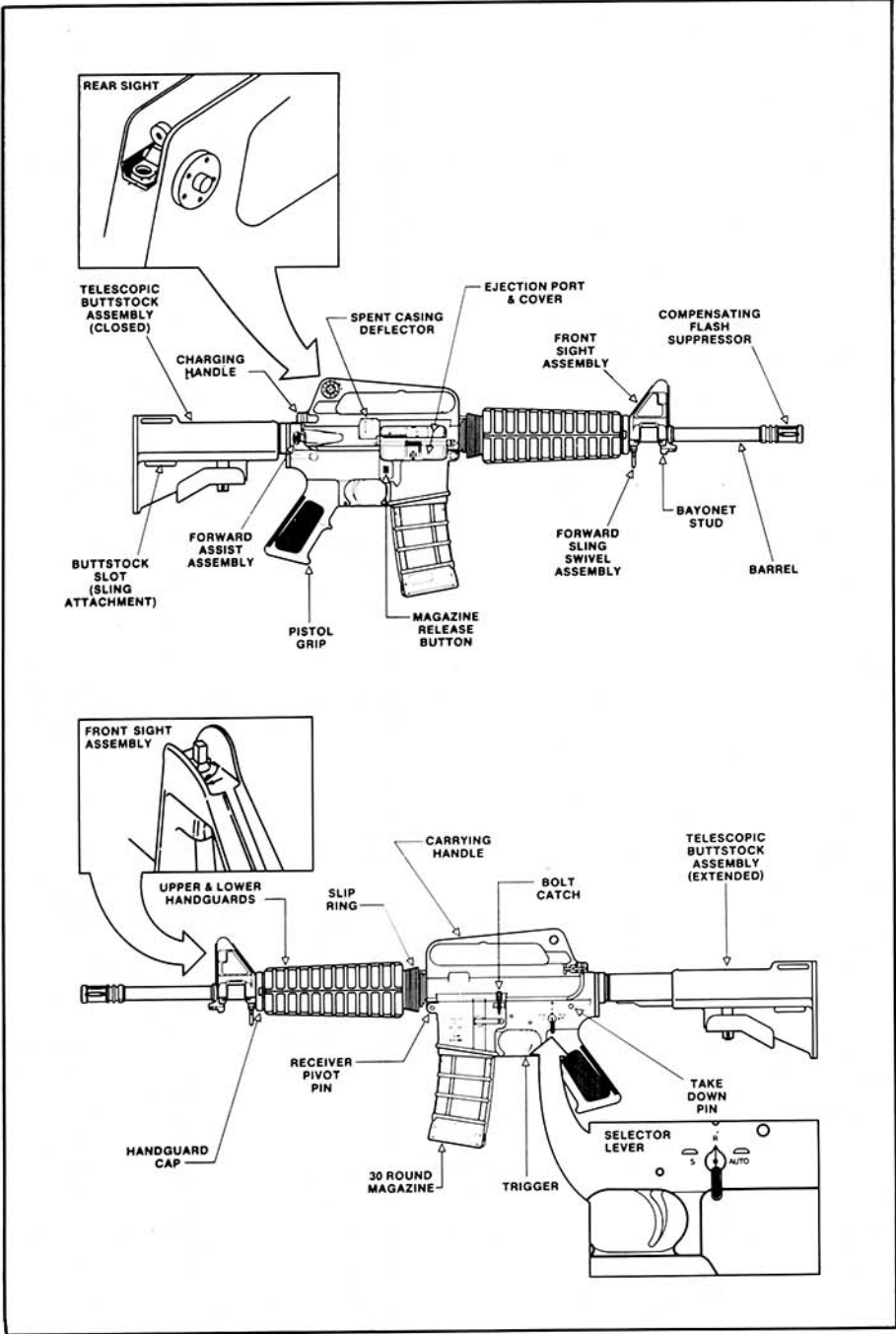

Figure 1-2 M8 Carbine

104. PRACTICE PERIODS

1. General. All training must be progressive; unnecessary repetition is bad instructional practice. A soldier learns skills and facts in the basic lessons which should be taught only once during his service. He then requires a lot of practice in order to speed up his actions and get the facts firmly fixed in his mind.
2. The sequence for each stage of a practice period is:
 - a. Remind - By explanation.
 - b. Assess Weaknesses - By practice or test.
 - c. Improve on Weaknesses - By practice.
 - d. Progressive Practice - By competitions.
3. The practice periods are intended as a guide to exercising soldiers during their training. The instructor should plan the period on an assessment of the soldier's weak points.
4. Faults should be immediately brought to the notice of the soldier and corrected, otherwise he will go on making the same mistakes.
5. If it becomes obvious during a practice period that the soldiers have failed to grasp a particular skill or fact the instructor will have to teach that part of the basic lesson again.
6. Practice periods can be repeated according to the progress. Instructors should remember that constant instruction and practice without firing make the subject boring and every effort should be made to introduce live firing in the sequence as soon as is feasible.
7. Competition. The incentive of competition will always help to make practice more interesting. The whole of a practice period can be based on competitions if the instructor so wishes. Some points on framing competitions are:

- a. They may be on an individual or on a team basis.
 - b. If run on a team basis the instructor must ensure that the selected teams are all fairly equal as regards performance. The more advanced members of the team will help along the weaker members.
 - c. Marks can be awarded up to a given total, or a total started with and marks deducted for mistakes as the competition progresses.
 - d. A chart drawn on a chalkboard or a sheet of paper on which to mark up results should always be used.
 - e. Further interest can always be attained by making one team or individual watch another, criticising and awarding or deducting marks.
 - f. Above all the instructor must make certain that competitions are simple and realistic, ie, that they exercise the soldiers in the facts and skills concerning their training.
8. **Master and Pupil.** The master and pupil method of practice in its simplest form is for one man (the pupil) to work under the supervision of another (the master); the instructor keeps an eye on both.
9. At all stages of training it stimulates interest, keenness and attention to detail. It is particularly useful with large squads and in competitions. Used regularly, it also develops initiative and leadership and potential leaders may well be discovered by watching the masters at work.

105. **LEFT HANDED FIRERS**

1. The subject matter has been written and illustrated for the right handed firer but can be adapted by the instructor for teaching the left handed firer. When a recruit shows a natural aptitude to shoot from the left shoulder every encouragement should be given him to do so.

106. SHOOT-TO-LIVE

1. CFP 318(6) Part 1 contains the Canadian Forces policy for small arms training under the Shoot-To-Live concept and provides guidance for its implementation. It is imperative that the precepts contained in CFP 318(6) Part 1 are understood and implemented in conjunction with the training detailed in this manual.

2. CFP 318(6) Part 2 contains the information necessary to enable small arms instructors to teach marksmanship and coaching.

107. CLASSROOM DRILLS

1. Prior to the commencement of all lessons number the class as individuals or as groups of two as necessary. Ideally there should be no more than ten students per instructor. Each student and the instructor should have a weapon.

108. SAFETY PRECAUTIONS

1. Before and after every lesson all weapons, belts, ammunition boxes, dummy cartridges and soldiers' pouches must be inspected to ensure that no live ammunition is present.

(109 to 199: Not Allocated)

CHAPTER 2
LESSON PLANS - BASIC SKILLS
LESSON 1 - INTRODUCTION

201. GRAPHICS

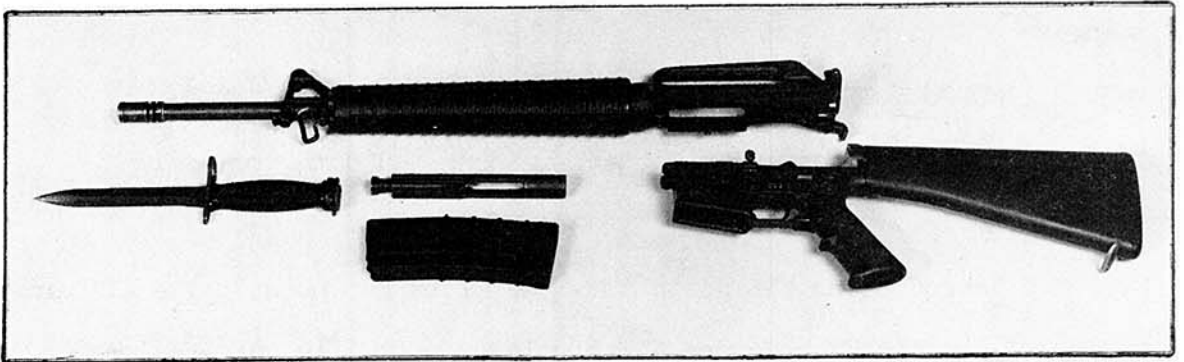

Figure 2-1 Layout for Instruction

202. INSTRUCTOR'S NOTES

1. Aim. To teach the description, technical data and safety precautions.
2. Timing. One 40-minute period.
3. Method. A basic instructional period.
4. Stores
 - a. Rifles 1 per soldier
 - b. Magazines 2 per soldier
 - c. Bayonet and scabbard 1 per instructor
 - d. Cleaning kit 1 per soldier
 - e. Dummy rounds 10 per soldier
 - f. Table 1

5. **Preparation**

- a. Examine available vifoils and other training aids.
- b. Check weapons for serviceability.
- c. Layout one weapon for instruction, see Figure 2-1.

6. **Miscellaneous.** When handling rifle parts; name them and identify their purpose. At this stage the student is not expected to memorize all of the names.

203. **CONDUCT OF THE LESSON**

1. **Preliminaries.** Inspect all weapons and dummy rounds.

2. **Review.** Nil.

3. **Introduction.** Explain that the C7 is the principal small arms weapon of the Canadian Forces. Its role is virtually universal as it is used throughout the range of conflict from nuclear war to peacekeeping and internal security.

4. The C7 rifle is the primary weapon for infantry use.

5. The C8 carbine is the primary weapon for those armoured vehicle crew members in whose vehicles there is insufficient space to stow the C7 rifle. Its reduced size and subsequent reduced performance capabilities are listed in the technical data. The C8 carbine functions and is operated in an identical manner to the C7 rifle. Throughout this publication the C7 rifle will be used as the vehicle of instruction.

6. **Characteristics.** Explain that the C7 rifle 5.56 mm is a gas-operated, magazine-fed, air-cooled, semi-automatic or automatic weapon.

7. It is capable of a high rate of accurate fire and may be fired using aimed or instinctive fire.

8. **Description.** The rifle consists of the following major components:

- a. the upper receiver group, and
- b. the lower receiver group.

9. These components are locked together by a pivot pin located forward of the magazine opening and a take down pin located immediately forward of the butt. Both locking pins are set in the lower receiver group.

10. Upper Receiver Group. Explain that the upper receiver group comprises the upper receiver, barrel and bolt, see Figure 2-1.

- a. Upper Receiver. The upper receiver is fixed to the barrel and houses the bolt and cocking handle. A carrying handle which incorporates the rear sight is attached to the top of the upper receiver. The ejection port is situated on the right side of the upper receiver and is protected by a dust cover which is opened by the forward or rearward movement of the bolt. A manually operated forward assist fitted on the right rear of the upper receiver is always used to push the bolt fully forward.
- b. Barrel. The barrel is fitted with a flash suppressor and is surrounded by two interchangeable aluminum-lined, glass filled, nylon handguards which are notched to allow air to circulate. The handguards also serve to protect the gas tube. The front sight assembly is fixed to the barrel.
- c. Bolt. The bolt is operated by the cocking handle located at the top rear of the upper receiver group. The bolt has a rotating head which locks into the barrel when the weapon is to be fired. The face of the bolt head is centrally holed to allow the firing pin to move forward to strike a chambered round.

11. Confirm by Questions.

12. Lower Receiver Group. Explain that the lower receiver group comprises the lower receiver and butt, see Figure 2-1.

a. Lower Receiver. The lower receiver contains the trigger mechanism, pistol grip and magazine opening. A three position selector lever is located on the left side: 'S' (SAFE), 'R' (REPETITION) and 'AUTO' (AUTOMATIC). The selector lever cannot be placed on 'S' until the weapon is cocked. A bolt catch, located on the left side, enables the bolt to be held open, or released from the open position. A magazine release button is located on the right side.

b. Butt. The butt is made of glass fibre reinforced nylon and incorporates a storage compartment for a cleaning kit. Access to this compartment is gained through the butt plate. The upper portion of the butt houses a buffer and a return spring. The butt is available in two lengths; normal and short.

13. Confirm by Questions.

14. Technical Data, C7 Rifle. Explain and demonstrate:

a. Calibre - 5.56 x 45 mm NATO

b. Weight

Rifle - 3.3 kg

Loaded 30 round mag - 0.5 kg

c. Length

Rifle - 990 mm

Barrel - 508 mm

Sight Radius - 500 mm

- d. Rifling - 6 groove, right hand,
1 turn in 178 mm
 - e. Cyclic Rate of Fire - 700 to 940 rpm
 - f. Modes of Fire - repetition and automatic
 - g. Operation - gas operated, air cooled,
magazine fed.
 - h. Sights - large aperture (battle)
0-200 m and low light.
- small aperture 200-300 m
 - j. Effective Range - 400 m
15. Technical Data C8 Carbine. Explain and demonstrate:
- a. Calibre - 5.56 x 45 mm NATO
 - b. Weight
 - Carbine - 2.8 kg
 - Loaded 30 round magazine - 0.5 kg
 - c. Length
 - Extended - 840 mm
 - Collapsed - 760 mm
 - Barrel - 370 mm
 - Sight Radius - 372 mm
 - d. Rifling - 6 groove, right hand,
1 turn in 178 mm
 - e. Cyclic Rate of Fire - 700 to 950 rpm
 - f. Modes of Fire - repetition and automatic
 - g. Operation - gas operated, air cooled,
magazine fed
 - h. Sights - large aperture (battle)
- small aperture + 200 m
 - j. Effective Range - 300 m

16. Blank Firing Attachment (BFA). Explain and demonstrate the FN screw-on type BFA. It must be cleaned frequently. When firing, a weak report indicates that it has worked loose.
17. Confirm by Questions.
18. Safety Precautions. Explain and demonstrate.
 - a. On the order **FOR INSPECTION - CLEAR WEAPON -**
 - (1) bring the rifle to the standing load position, see Figure 2-16, ensure that the finger is outside the trigger guard, and
 - (2) grasp the cocking handle in an overhand grasp, pull the action to the rear and hold it there.
 - b. On the order **CLEAR -**
 - (1) allow the action to go forward under control,
 - (2) fire the action and close the ejection port cover,
 - (3) ground the rifle with the ejection port up and the front sight in line with the toe of the right boot, and
 - (4) remove all magazines and dummy rounds from pouches.
 - c. In a classroom situation the instructors' pouches, magazines and dummy rounds are to be inspected by one of the students.
 - d. The instructor must inspect all pouches, magazines and dummy rounds to ensure there are no live rounds present.
 - e. Upon completion of these drills the soldiers are to replace all dummy rounds and magazines in the pouches, fasten their pouches, pick up their rifles and **STAND - AT EASE.**
 - f. These actions will be carried out -
 - (1) before and after instruction,
 - (2) before stripping,

- (3) during issue and return to stores,
 - (4) before and after range practices, and
 - (5) when the safety status of the weapon is in doubt.
19. Confirm by Questions and Practice.
20. Safe Handling With No Magazine Fitted. Explain and demonstrate.
- a. On handing a rifle to another soldier or on picking up a rifle, point the muzzle in a safe direction and carry out the following actions -
 - (1) pull the cocking handle to the rear,
 - (2) show that the chamber is clear,
 - (3) allow the action to go forward under control, and
 - (4) fire the action.
 - b. Never point the rifle at anyone in jest.
21. Confirm by Practice.
22. Conclusion
- a. Take questions from the class on the entire lesson.
 - b. Confirm by questions.
 - c. Pack kit.
 - d. Summary. To include the following:
 - (1) the importance of understanding the capabilities and components of the weapon;
 - (2) the importance of safe weapon handling; and
 - (2) a forecast of the next lesson in this subject.

LESSON 2 - STRIPPING, ASSEMBLING AND CLEANING

204. GRAPHICS

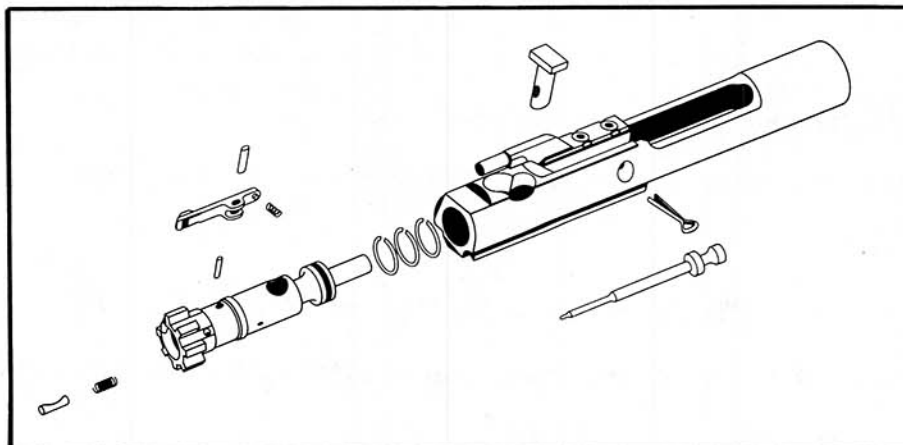

Figure 2-2 Bolt, Bolt Carrier and Firing Pin

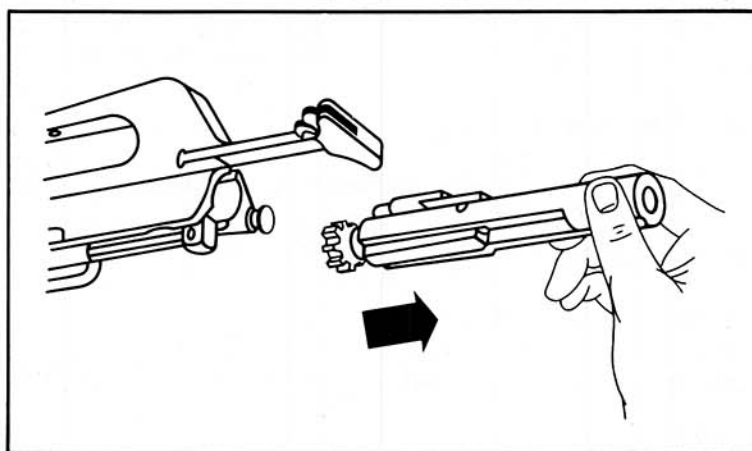

Figure 2-3 Remove Bolt Carrier Assembly

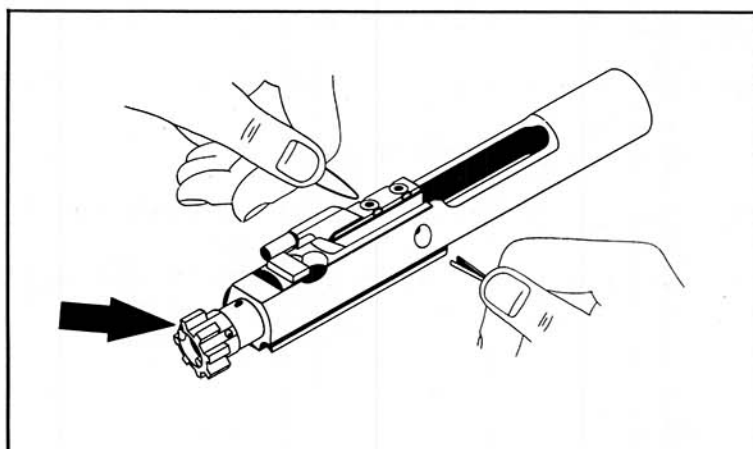

Figure 2-4 Withdraw Retaining Pin

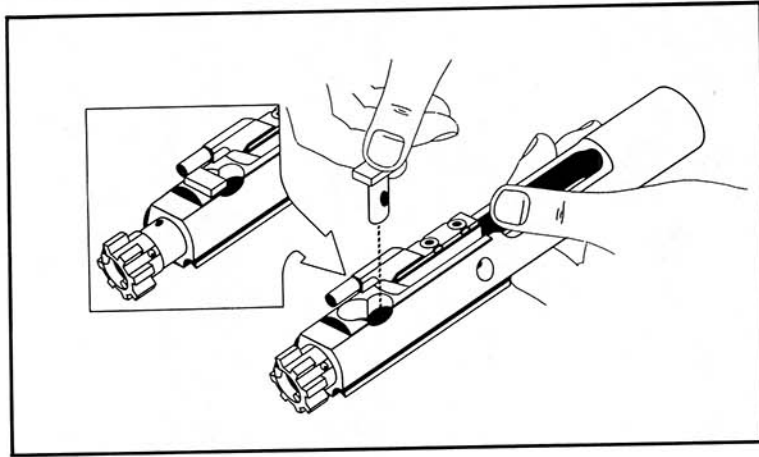

Figure 2-5 Remove Cam Pin

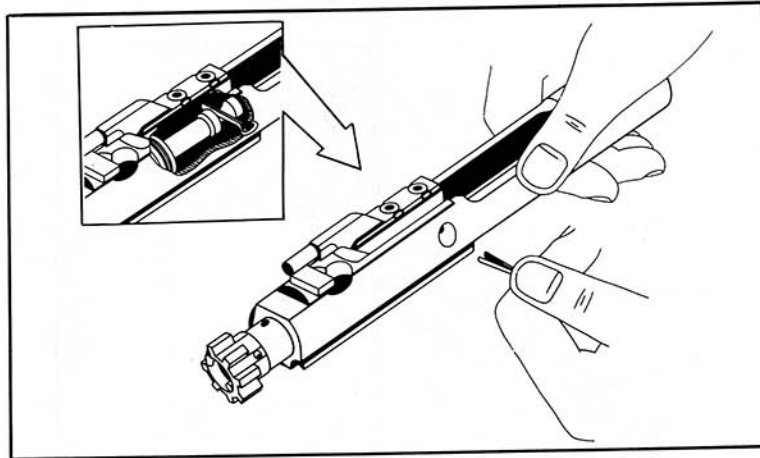

Figure 2-6 Proper Location of the Firing Pin Retaining Pin

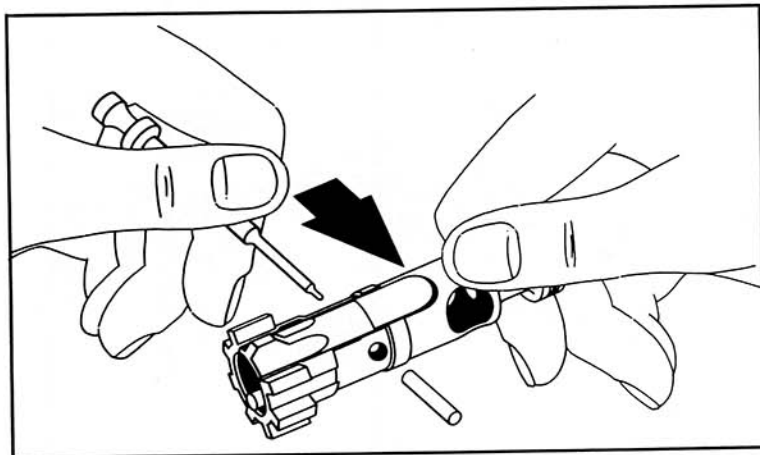

Figure 2-7 Extractor Pin Removed

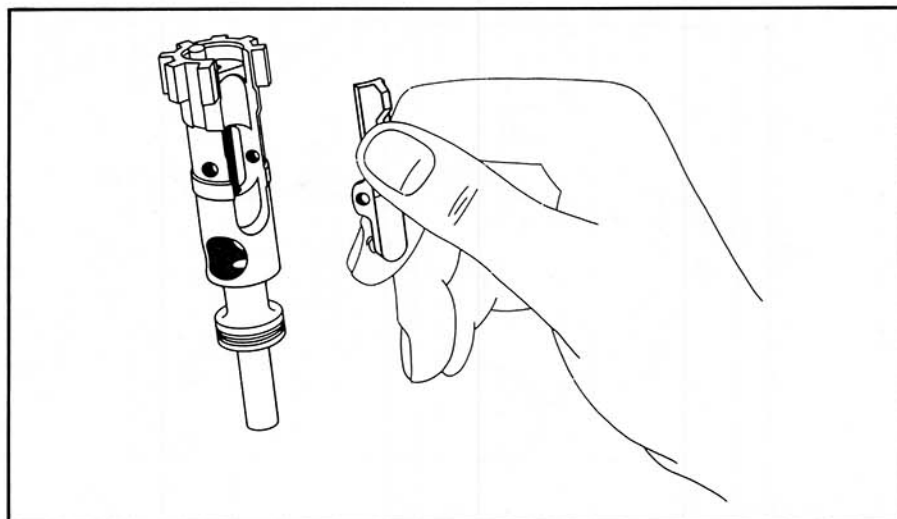

Figure 2-8 Extractor Removed

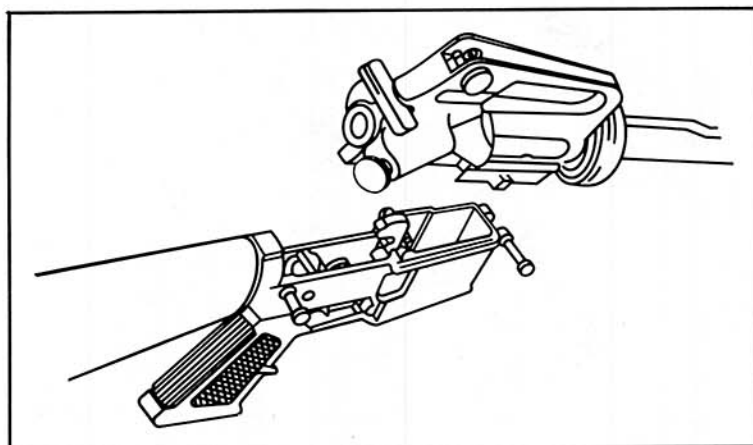

Figure 2-9 Receivers Separated

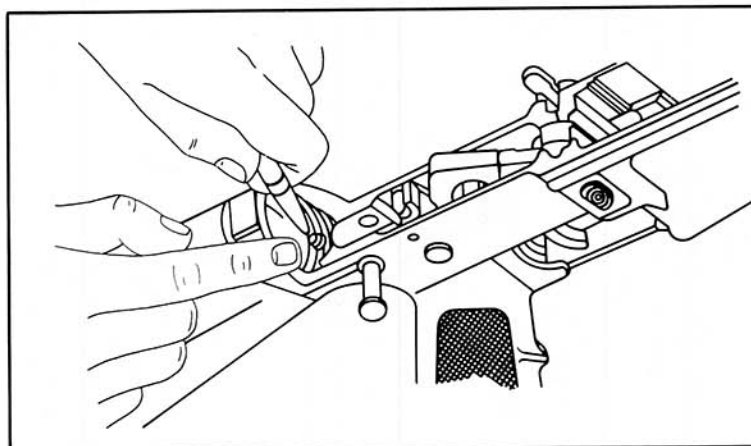

Figure 2-10 Depress Buffer Retainer

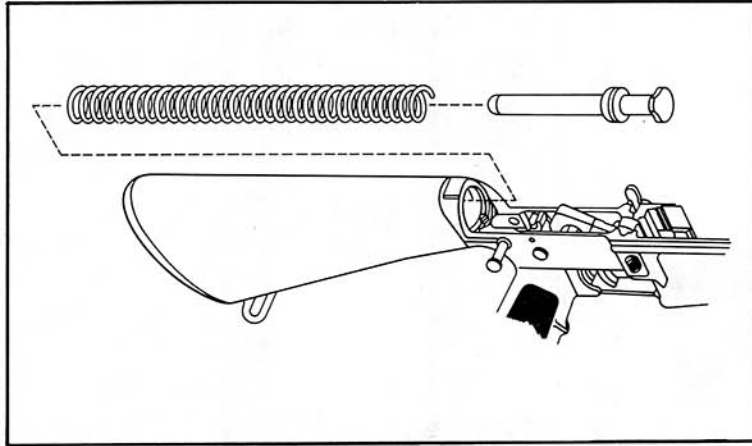

Figure 2-11 Buffer and Return Spring Removed

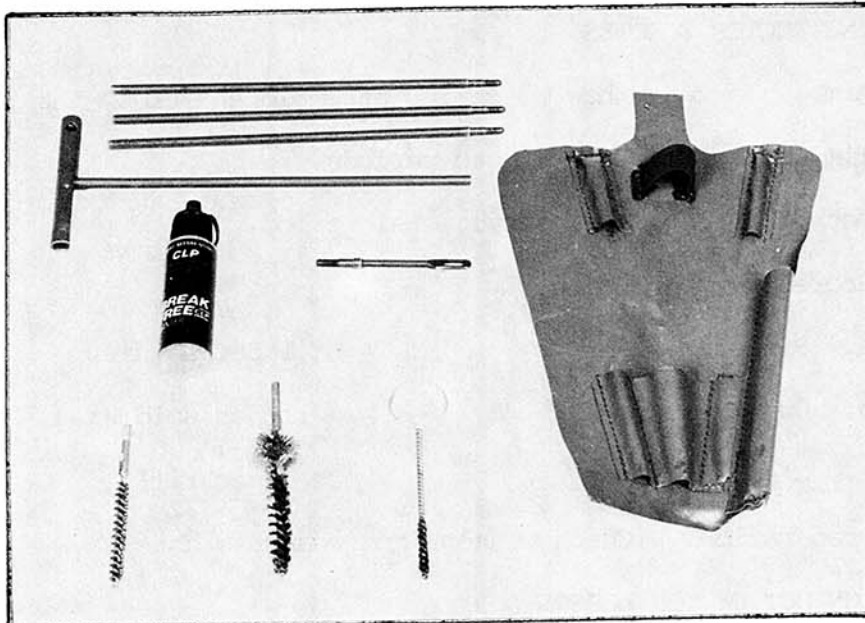

Figure 2-12 Cleaning Kit

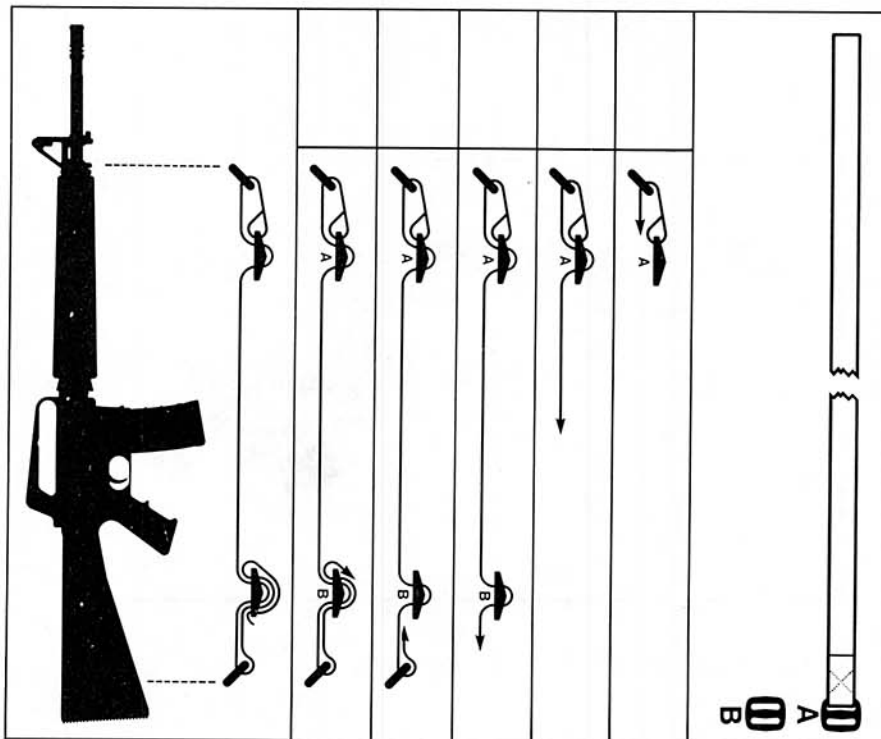

Figure 2-13 General Purpose Sling

205. INSTRUCTOR'S NOTES

1. Aim. To teach how to strip, assemble and clean the rifle.
2. Timings. Three 40-minute periods.
3. Method. A basic instructional period.
4. Stores
 - a. Rifles 1 per soldier
 - b. Dummy rounds 1 per soldier
 - c. Cleaning kits 1 per rifle
5. Preparation. Check weapons and weapon sights.

206. CONDUCT OF THE LESSON

1. Safety Precautions. Normal. Emphasize importance of procedure as taught in lesson one.
2. Review. Time normally allotted for review should be devoted to detailed practice of safety precautions.

3. Introduction. Explain that there are two degrees to which a rifle can be stripped: field strip and detailed strip. In order to clean and maintain the rifle properly, the soldier must know how to strip and assemble it. The rifle will not be stripped by the user beyond the detailed stripping described in this lesson.
4. Field Stripping. Explain and demonstrate.
 - a. Carry out safety precautions.
 - b. Cock the rifle and set the selector lever at 'S'.
 - c. Push/pull the takedown pin to the right. Pivot the upper receiver group upwards.
 - d. Pull the cocking handle partially to the rear and pull the bolt carrier group out of the upper receiver, see Figure 2-2. Push the cocking handle fully forward, see Figure 2-3.
 - e. Remove the retaining pin from the bolt carrier and slide the firing pin out of the rear of the bolt carrier, see Figure 2-4.
 - f. Rotate the bolt until the cam pin is clear of the bolt carrier key. Rotate the cam pin one quarter turn and remove it from the bolt carrier, see Figure 2-5.
 - g. Pull the bolt out of the bolt carrier. DO NOT STRIP THE BOLT.
 - h. Strip the 30-round magazine by inserting the nose of a round into the indent and lift the base plate off. Pull out and separate the spring and platform.
5. Assembling. Explain and demonstrate.
 - a. Assemble in the reverse order. See Figure 2-6 for the correct position of the firing pin retaining pin.

- b. Ensure the selector lever is at 'S'. If the selector lever is at 'AUTO' the automatic sear will interfere with the bolt carrier when the upper receiver is closed down upon the lower receiver.
6. Confirm by Practice.
7. Function Test. Explain and demonstrate.
 - a. Cock the rifle. With the selector lever at 'S', attempt to fire the rifle. It should not fire.
 - b. Set the selector lever at 'R'. Squeeze the trigger, firing the action. While holding the trigger back, cock the action and release the trigger. The hammer should be felt/heard to fall from the disconnect, then to be caught immediately by the trigger sear. Squeeze the trigger; the action should fire.
 - c. Set the selector lever at 'AUTO'. Cock the rifle. The hammer should be held by the automatic sear. Squeeze the trigger, firing the action. While holding the trigger to the rear, cock the action. As the bolt carrier moves fully forward, the hammer should fall to strike the firing pin. Release the trigger. Set the selector lever to 'R'. Close the ejection port cover.
8. Confirm by Practice. Leave rifle field stripped.
9. Detailed Stripping. Detailed stripping is done for comprehensive cleaning. Explain and demonstrate.
 - a. Using the firing pin, push the extractor retaining pin out from the bolt, see Figure 2-7. Lift the extractor and extractor pin up from the bolt, see Figure 2-8.
 - b. Do not separate the extractor spring from the extractor.
THE EJECTOR WILL NOT BE STRIPPED FROM THE BOLT.

- c. Remove the handguards from the upper receiver assembly by pulling the handguard slip-ring toward the upper receiver, then lift each handguard away from the handguard cap.
 - d. Push/pull the receiver pivot pin at the front of the magazine housing and separate the upper receiver from the lower, see Figure 2-9.
 - e. Remove the cocking handle from the upper receiver.
 - f. While holding the lower receiver depress the buffer retaining pin slightly, see Figure 2-10. Slowly ease the buffer and return spring forward until they are clear of the buffer retaining pin. It may be necessary to depress the hammer to allow the buffer and return spring to clear it as they are pulled out of the butt and receiver extension assembly.
 - g. Separate the buffer and the return spring, see Figure 2-11. Set the selector lever to 'R'. Controlling the hammer, fire the action.
 - h. NO FURTHER STRIPPING WILL BE DONE BY THE RIFLEMAN.
10. **Assembling.** Explain and demonstrate.
- a. Assemble in the reverse order.
 - b. Ensure the selector lever is set to 'S'.
 - c. Function test.
11. **Confirm by Practice.** Leave rifle field stripped.
12. **Cleaning.** Explain that regular maintenance of the rifle by cleaning and inspection is essential and is to be carried out:
- a. on a regular basis, as required,
 - b. before firing, and
 - c. after firing.

13. The Cleaning Kit. See Figure 2-12. The kit is contained in a case in the butt. It consists of:

- a. the case,
- b. a 4 piece rod,
- c. a swab holder,
- d. a bore brush,
- e. a chamber brush,
- f. a bolt key brush,
- g. a container of Cleaner, Lubricant, Preservative (CLP),
- h. pipe cleaners, and
- j. swabs.

14. Cleaner, Lubricant, Preservative. Explain that the maintenance concept is to use CLP for all temperatures and conditions. No other oil, solvent or lubricant is to be used. The CLP must be shaken vigorously before use to ensure that the Teflon particles are returned to suspension. It should be applied in very limited amounts as too much may clog the mechanism. Even when wiped dry the lubricant is still at work on the weapon. In most cases a small drop of CLP is sufficient.

15. Regular Cleaning. Explain and demonstrate.

a. Barrel

- (1) Insert the cleaning rod, without the bore brush attached, into the muzzle end.
- (2) Attach the bore brush.
- (3) Pull through from chamber to muzzle in one continuous motion. Do not scrub to and fro.
- (4) Pull through a dry swab.
- (5) Pull through a very lightly lubricated swab.

b. Chamber

- (1) Clean with the chamber brush fitted to the cleaning rod handle.
- (2) Dry and lightly lubricate the chamber.

c. Bolt and Carrier

- (1) Clean the interior of the bolt key using the bolt key brush. Dry using a pipe cleaner and lightly lubricate.
- (2) Clean the firing pin, extractor and all surfaces using a swab. Dry and very lightly lubricate.
- (3) Do not use an excessive amount of lubricant as misfires may occur.

d. Upper Receiver

- (1) Clean external surfaces using a swab.
- (2) Do not use wire brushes on aluminium surfaces.
- (3) Clean the exterior of the gas tube which protrudes into the upper receiver.
- (4) Dry and lightly lubricate the inner and outer surface of the upper receiver.

e. Lower Receiver

- (1) Clean the trigger mechanism with a swab.
- (2) Dry and lightly lubricate.

f. Butt and Handguards

- (1) Clean external surfaces.
- (2) Do not oil nylon surfaces.

g. Flash Suppressor

- (1) Clean using bore cleaning brush.

h. Magazine

- (1) Wipe with a dry swab.
- (2) Lightly lubricate the spring.
- (3) Do not oil the body or magazine platform.

j. Bayonet and Scabbard

- (1) Clean and lightly lubricate metal parts.

16. Confirm by Practice.

17. Cleaning Before Firing. Inspect the weapon to determine if it requires additional cleaning. In most cases wiping exposed surfaces will be sufficient. If it is necessary to clean the weapon it should be done as for regular cleaning except that the bore, face of the bolt and the chamber must be free of lubricant.

18. Cleaning After Firing. As soon as possible after firing, a light film of CLP should be applied to the gas affected parts. If possible the CLP should be allowed to work on the weapon for a minimum of 30 minutes. Following that period, regular cleaning should be carried out.

19. Cleaning in Adverse Conditions. Explain that in adverse conditions special cleaning measures may be necessary.

- a. Hot, Dusty and Sandy Areas. Clean often. Wipe CLP from the exposed surfaces with a clean rag.
- b. Extremely Cold Climate. Keep the weapon dry. Apply CLP lightly. The CLP will provide the required lubrication at temperatures between -18°C and -37°C . However, it must be warmed to flow from the bottle below -18°C .
- c. Hot, Wet Climate. Keep the weapon dry. Inspect often. Apply CLP lightly.

- d. Water Emersion. If there is a possibility of emersion, hold the action to the rear and empty the chamber. When the weapon is removed from the water shake vigorously with the muzzle up. Release the action. As soon as possible, disassemble, dry thoroughly, clean and apply CLP.
20. Confirm by Questions and Practice.
21. Sling. The general purpose sling is mounted in accordance with the procedures shown in Figure 2-13.
22. Confirm by Practice.
23. Conclusion
 - a. Take questions from the class on the entire lesson.
 - b. Confirm by questions.
 - c. Pack kit.
 - d. Summary. To include the following:
 - (1) the importance of proper cleaning procedure; and
 - (2) a forecast of the next lesson in this subject.

LESSON 3 - AMMUNITION HANDLING, SIGHT ALTERATION, LOAD, PREPARE
TO FIRE, UNLOAD AND MAKE SAFE

207. GRAPHICS

"NOT AVAILABLE AT TIME OF PRINTING"

Figure 2-14 Magazine Changer

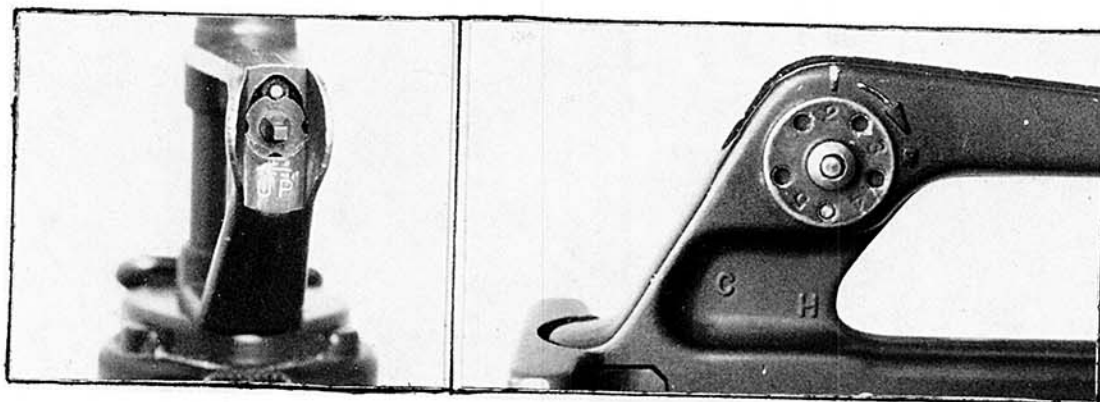

Figure 2-15 Front and Rear Sight



Figure 2-16 Standing-Load Position

208. INSTRUCTOR'S NOTES

1. Aim. To teach:
 - a. the care of ammunition and magazine filling,
 - b. sight alteration,
 - c. how to load, prepare to fire, make safe and unload, and
 - d. safety precautions with a magazine fitted.
2. Timings. Two 40-minute periods.
3. Method. A basic instructional period.
4. Stores
 - a. Rifles 1 per soldier
 - b. Dummy rounds 20 per soldier

5. Preparation

- a. Examine the sights of all rifles.
- b. Ensure dummy rounds are not damaged.

209. CONDUCT OF THE LESSON

1. Safety Precautions. Normal.

2. Review. Sight description from Lesson One.

3. Introduction. Explain that it is essential that the soldier is capable of maintaining his rifle in a state of readiness under battle conditions and is aware of the need for safe handling.

4. Ammunition Description. Explain.

- a. The ammunition is rimless.
- b. The calibre is 5.56 mm.
- c. The complete cartridge length is 57.4 mm.
- d. The muzzle exit velocity is 944 metres per second.

5. Care of Ammunition. Always ensure ammunition is clean and undamaged prior to loading it in the magazine.

6. Do not let ammunition lie in the direct rays of the sun for extended periods as the absorbed heat can cause inaccuracies.

7. Magazine Filling. Explain that ammunition may be filled into a magazine either by hand or with the aid of a magazine charger, see Figure 2-14.

8. The Magazine Charger. Explain and demonstrate.

- a. Place the charger on the magazine.
- b. Place a 10 round clip in the charger.
- c. With either thumb on the top round force the rounds down until the top round is caught by the magazine lips.

9. Sight Alteration. Explain and demonstrate.

- a. Elevation Correction. Each notch of the front sight base

changes the Mean Point of Impact (MPI) 2.8 cm at 100 m range. To raise the MPI, turn the front sight post clockwise, in the direction of the arrow, and vice versa, see Figure 2-15.

- b. Deflection Correction. Each notch of the rear sight drum moves the MPI laterally 2.8 cm at 100 m range. To move the MPI to the right, turn the rear sight clockwise, in the direction of the arrow, and vice versa, see Figure 2-15.

10. Confirm by Questions and Practice.

11. Weapon Handling Drills. Explain.

- a. The rifle is LOADED when it has a magazine on it. It is PREPARED TO FIRE when the sight is set, it is cocked, and a live round is in the chamber. It is UNLOADED when it has no magazine on and no round in the chamber.
- b. The rifle will normally be loaded in the standing position and the soldier will subsequently adopt any firing position which may be ordered. Should he be required to load the rifle in any other position he is to be given the order KNEELING, ETC...LOAD. The rifle is to be unloaded in the position adopted at the time the order is given to unload.

12. Load. Explain and demonstrate with the class imitating.

- a. On the order LOAD -
 - (1) adopt the standing - load position, see Figure 2-16, hold the rifle by the pistol grip, forefinger outside the trigger guard, muzzle pointed upward,
 - (2) unfasten the ammunition pouch and tilt the rifle to the right,
 - (3) remove a designated magazine from the pouch and place it securely on the rifle, and
 - (4) secure the ammunition pouch.

13. Confirm by practice.
14. Prepare to Fire - Action on Range Being Ordered. Explain and demonstrate.
 - a. On a range being ordered -
 - (1) set the sight,
 - (2) cock the rifle,
 - (3) ensure the bolt carrier moves fully forward - DO NOT RIDE THE COCKING HANDLE,
 - (4) strike the forward assist assembly,
 - (5) close the ejection port, and
 - (6) set the selector level to 'S'.
15. Confirm by practice.
16. Unload. Explain and demonstrate.
 - a. On the order UNLOAD -
 - (1) set the selector lever to 'S',
 - (2) remove the magazine,
 - (3) point the muzzle upward, tilt the rifle to the right and pull the cocking handle to the rear twice,
 - (4) hold the cocking handle to the rear, tilt the rifle to the left and look or feel to ensure that the chamber is empty,
 - (5) let the cocking handle go forward,
 - (6) set the selector lever to 'R' and squeeze the trigger,
 - (7) recover the ejected round, clean and replace it in the magazine, and put the magazine in the pouch, and
 - (8) close the ejection port cover.
17. Confirm by Practice. Leave the rifle loaded.
18. Make Safe. Explain and demonstrate.
 - a. On the order MAKE SAFE -

- (1) unload, and
 - (2) load.
19. **Confirm by Practice.**
20. **Safe Handling With a Magazine Fitted.**
- a. Once ordered to load the rifle the soldier is responsible for keeping it loaded until ordered to unload. He is responsible for the safe handling of his rifle. He is to ensure-
 - (1) The selector lever is always at 'S' unless an order to fire has been given,
 - (2) the rifle is always unloaded when he is no longer able to ensure its safe handling, eg, when it is handed over to another person or left under guard while he is performing some duty,
 - (3) the muzzle is always pointed at the sky, at the ground or in the direction of the target,
 - (4) if a rifle is picked up with a magazine fitted it is to be unloaded immediately, and
 - (5) the rifle is never pointed at anyone in jest.
21. **Confirm by Practice.**
22. **Conclusion**
- a. Take questions from the class on the entire lesson.
 - b. Confirm by questions and practice.
 - c. Conduct normal safety precautions.
 - d. Pack kit.
 - e. Summary. To include the following:
 - (1) the importance of safe handling when the rifle is fitted with a magazine; and
 - (2) a forecast of the next lesson in this subject.

LESSON 4 - HOLDING AND AIMING

210. GRAPHICS



Figure 2-17 Prone Position

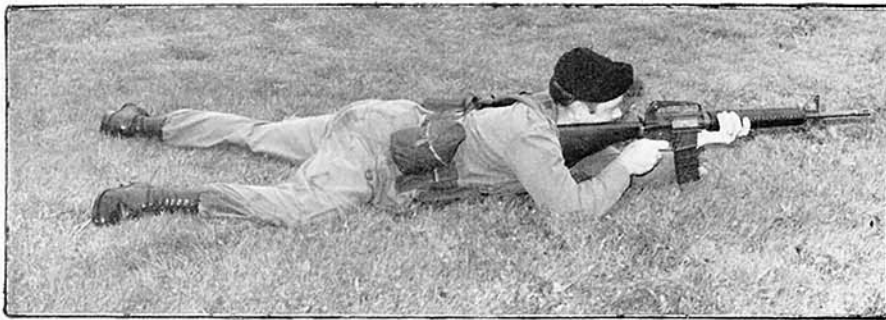

Figure 2-18 Modified Prone Position



Figure 2-19 Holding In the Prone Position

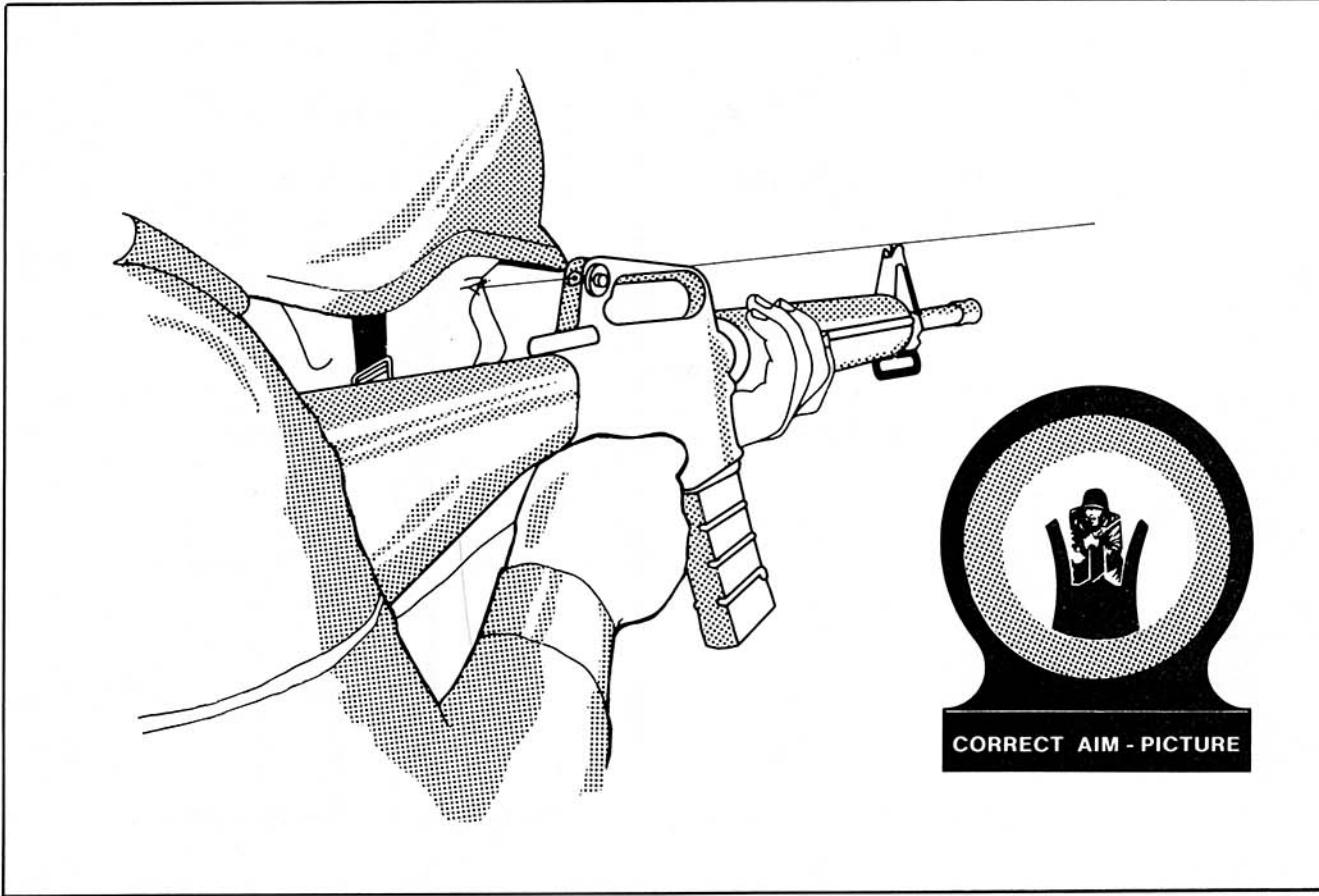

Figure 2-20 Correct Aim Picture.

211. **INSTRUCTOR'S NOTES**

1. **Aim.** To teach how to hold the rifle correctly in the prone position and how to take a correct aim.
2. **Timings.** Two 40-minute periods.
3. **Method.** A basic instructional period that can be taken indoors in a classroom or outside on the training area.

4. Stores

- a. Rifles 1 per soldier
- b. Eye discs 1 per soldier
- c. Half filled sandbags 1 per soldier
- d. Sight picture diagrams 1 per soldier
- e. Targets:
 - Figure 11 with 75 mm
 - by 100 mm removable aiming 1 per soldier
 - mark and Figure 12 1 per soldier

5. Preparation

- a. Put out targets at 100 metres or representative targets at a shorter distance.
- b. Examine all sights to ensure they are in good condition.

6. Miscellaneous

- a. Rifles are available with normal and short butts. The vast majority of firers will use a normal butt. If the normal butt is obviously too long for a firer a change should be made.
- b. If a firer shows a natural ability to shoot from the left shoulder he should be allowed to do so.
- c. An eye disc should be used to check steadiness and sight alignment. To use an eye disc correctly the instructor's eye disc should be held in both hands with the elbows rested firmly on the ground. Look through the hole in the eye disc at the firer's eye, not at the foresight. To make the firer take a fresh aim, move the position of the eye disc slightly after each shot. Using the eye disc, a check can be made on the soldier's ability to hold, to aim and, in a later

lesson, to operate the trigger. Sufficient eye discs should be available to enable the master and pupil method of practice to be used. Eye discs can be improvised from cardboard or representative snap targets.

<p>CAUTION</p> <p>DUMMY ROUNDS AND EYE DISCS ARE NEVER TO BE USED AT THE SAME TIME.</p>
--

- d. It is not possible to focus on two objects at different distances at the same time. It is important that both the instructor and the students understand this fact and closely follow the instruction in sub-paragraph c.
- e. During the practice of testing and adjusting in the prone position allow the class to rest their forearms against half filled sandbags if they have difficulty in holding their rifles steady at this stage.
- f. It is essential that the instructor fully understands the Marksmanship Principles before teaching this lesson.

212. CONDUCT OF THE LESSON

- 1. Safety Precautions. Normal.
- 2. Review. Loading, sightsetting, unloading. Leave the rifles loaded with an empty magazine. Ensure the dummy rounds are returned to the pouches. Explain the use of the eye disc.
- 3. Introduction. Explain that it is essential that a soldier is capable of firing his rifle accurately and instinctively under battle conditions. This can be achieved if he understands and applies the following marksmanship principles:

- a. The position and hold must be firm enough to support the rifle.
- b. The rifle must point naturally at the target without any physical effort.
- c. Sight alignment (aiming) must be correct.
- d. The shot must be released and followed through without disturbing the position.

4. The Prone Position. See Figure 2-17. Explain and demonstrate.

The basic shooting position is the prone position, since it gives the firer the best support, presents a small target to the enemy and is the least tiring. On the command DOWN, advance the left foot and hold the rifle in front of the body with the left hand around the handguard. Lie down, breaking the fall with the right hand. Note the following points:

- a. The flash suppressor must be kept clear of the ground.
- b. The body should be relaxed and form an angle of 200 mils with the line of fire. The left leg lies parallel to the direction of the body with the toes turned inwards and the leg muscles relaxed. The right leg is drawn up until the thigh is approximately 1600 mils to the line of the body and the lower part of the leg lies parallel to the line of fire. The right foot points outwards with the heel on the ground. By drawing up the right leg, the weight of the body is rolled to the left, thus allowing easier breathing and less restriction to the heart, which in turn reduces pulse beat. The firer is to adjust the position of the right leg to suit his build.

- c. If discomfort or difficulty is experienced in adopting the prone position the following modifications may be made:
 - (1) Lie slightly oblique to the line of fire with the legs apart. The line of the right leg will usually be along the line of fire, while the left leg is parallel with the spine, see Figure 2-18.
 - (2) Place the left elbow close into the rifle but not touching the magazine.
 - d. The rifle is supported by the left hand holding the hand-guard and the right hand firmly gripping the pistol grip. The index finger lies outside the trigger guard.
 - e. When standing up, place the right hand on the ground, draw the left hand holding the rifle to the rear, stand up.
5. Confirm by Practice.
6. Holding in the Prone Position. See Figure 2-19. Order DOWN..
- RANGE 200. Explain and demonstrate.
- a. Raise the large aperture.
 - b. Position the selector lever at 'R'. Lift the rifle and place the butt in the shoulder.
 - c. The left hand should be as far forward on the handguard as is practicable. The distance forward will vary from firer to firer and can be adjusted to some degree by a change of body position. The left elbow is brought as close to the rifle as possible without exerting lateral pressure against the magazine. The weight of the rifle is supported by the rear outside of the elbow joint, thus achieving bone support.

- d. The handguard should lie diagonally across the palm of the left hand and bear equally on the heel of the hand and the point below the index finger. No attempt should be made to either grip tight or pull backwards with the left hand; it should simply support the rifle and maintain steadiness.
- e. The position of the butt in the shoulder should not be too high, if it rests on the collar bone some pain may be felt on firing which may cause a tendency to flinch.
- f. The right hand is the controlling hand and must hold the pistol grip firmly. This must be done before the right elbow is positioned. The web between the finger and thumb should be directly behind the grip and as near to the top as possible. Better adhesion and therefore grip will be achieved if the palms are opened and the fingers fully extended before taking up the hold. With this grip the index finger should lie parallel to the axis of the barrel and rest naturally on the trigger. The right elbow must then be positioned and must not alter the position of the hand or index finger.
- g. The slack in the trigger should be taken up. The grip with the right hand must be unstrained and must pull the rifle back towards a firm shoulder. No attempt should be made to hunch the shoulder towards the butt plate.
- h. The cheek and not the cheek bone must be positioned naturally on the butt allowing the aiming eye to look squarely through the sights. The head must be upright.

h. If the magazine is rested on cover or ground, it is possible that there may be some displacement of shots.

8. **Confirm by Practice.**

9. **Aiming.** Explain and demonstrate.

a. Where to Aim. Aim at the lowest central point of the aiming mark on a target with an aiming patch. Aim at the middle of a man, a figure target or any indistinct target, see Figure 2-20. For large objects such as trees, buildings, or hedgerows, an exact point of aim will be indicated by the section commander.

b. How to Aim. Aiming can never become instinctive, though practice can induce speed. Above all, it requires concentration to achieve sight alignment together with the correct aim picture which is a four point relationship between the eye, the centre of the aperture, the tip of the foresight and the point of aim. The procedure for aiming is as follows:

(1) Close the eye not in use.

(2) Look through the centre of the aperture and centralize the tip of the foresight. The aperture is too close to the eye to be clearly seen, but the position of the top of the foresight protectors should help in centralizing the tip of the foresight.

(3) It may be necessary to move the head slightly in order to achieve correct sight alignment; it is essential, however, that once the tip of the foresight has been centralized, the position of the head remains unchanged.

(4) Maintaining this alignment, focus the tip of the foresight and place it on the point of aim to complete the aim picture. It should be noted that the aiming mark will be slightly blurred.

(5) Check that the sights are upright, and that the tip of the foresight is still central in the aperture.

- c. Eye Relief. It must be emphasized that eye relief for successive shots must be constant. By ensuring this the apparent size of the aperture remains the same and centralization of the foresight tip is simplified.

10. Confirm by Questions and Practice.

11. Testing and Adjusting the Position. Explain and demonstrate.

It is essential that the rifle points naturally at the target. To ensure that it does, the firer is to test and, if necessary, adjust his position as follows:

- a. Aim at the target, then relax the hold. No appreciable change of aim should be noticed. If the aim does move by any appreciable amount it is an indication that the position needs some adjustment.
- b. Keep the left elbow stationary and pivot the body to the right or left to correct any lateral errors. For errors in elevation, keep both elbows stationary and move the rest of the body forward or backward. The position of the butt in the shoulder should remain unchanged.
- c. To confirm that the position is correctly adjusted, rest the rifle, close the eyes and bring the rifle back to a comfortable position in the shoulder. When the eyes are opened,

the aim picture should be on or very close to the aiming mark. If further adjustment is needed it should be carried out as already taught.

- d. With practice it will become natural to adopt a position that requires little or no adjustment.

12. Confirm by Practice.

13. Conclusion

- a. Take questions from the class on the entire lesson.
- b. Confirm by questions and practice.
- c. Conduct safety precautions.
- d. Pack kit.
- e. Summary. To include the following:
 - (1) the importance of accurate aiming, alignment of sights and firm, correct holding, especially with the right hand; and
 - (2) a forecast of the next lesson in this subject.

LESSON 5 - FIRING IN THE PRONE POSITION

213. GRAPHICS

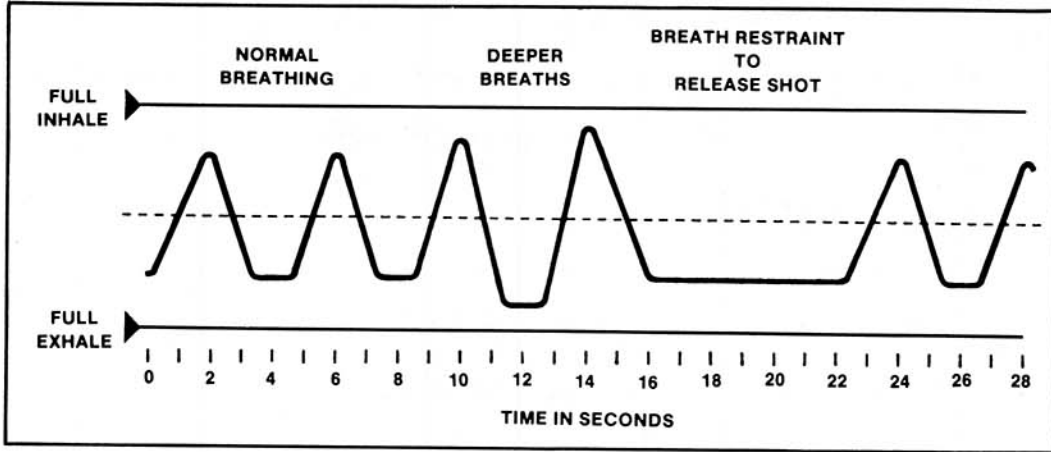

Figure 2-21 Breath Restraint

214. INSTRUCTOR'S NOTES

1. **Aim.** To teach how to fire the rifle in the prone position by combining the four marksmanship principles.
2. **Timings.** Two 40-minute periods.
3. **Method.** A basic instructional period.
4. **Stores**
 - a. Rifles 1 per soldier
 - b. Eye discs 1 per soldier
 - c. Figure or representative targets 2 per soldier
5. **Preparation**
 - a. Ensure all sights are in good condition.
 - b. If the period is to be taken outdoors every soldier lays down a groundsheet as a dry and marked base on which to work.
6. **Miscellaneous**
 - a. The soldier can only be taught to shoot properly on a range.

However, in this lesson the drill for firing can be taught without his worrying about the effect of firing a shot.

- b. After initial individual practice the eye disc should be used.

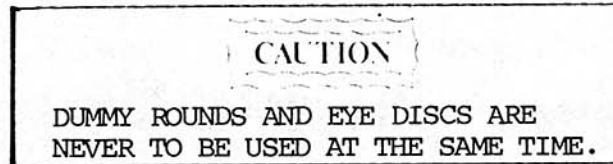

- c. The instructor must fully understand the Marksmanship Principles as defined in CFP 318(6) Shoot-to-Live, Part 2 - Marksmanship Theory and Coaching.

215. CONDUCT OF THE LESSON

1. Safety Precautions. Normal.
2. Review. Holding and aiming and the use of the eye disc.
3. Introduction. Explain that one of the marksmanship principles is that the shot is to be released and followed through without disturbing the position. This lesson deals with the technique the soldier requires in order to put into effect that principle and also combines all four principles in the prone position.
4. Firing the Shot. Explain that the shot should be fired without disturbing the aim. Provided that the position is stable with the rifle held firmly and pointing naturally at the target, all that is required is control of breathing and a smooth trigger operation. This allows the bullet to leave the muzzle without any undue movement of the weapon.
 - a. Breathing. Explain and demonstrate with the class imitating. Breathing is a natural body function which will continue without strain until an individual does something to disturb

the cycle. It is important, therefore that a firer restrains his breathing in a way which induces no strain, see Figure 2-21. To achieve this:

- (1) take two deep breaths to oxygenate the body;
- (2) slightly extend the natural pause between breathing out and in; and
- (3) release the shot within six seconds.

b. Trigger Operation. During the breathing pause it is necessary to perfect the aim as near as possible and squeeze the trigger without disturbing the aim. Trigger slack should be taken up just before restraining the breath and perfecting the aim. It is important that the squeezing action of the trigger finger is achieved without moving or reducing the grip of the right hand.

5. **Confirm by Practice.**

6. **Follow Through and Declaration.** Explain and demonstrate.

- a. Follow Through. Operation of the trigger does not complete the sequence of firing a shot. The firer must try to remain on aim, watching the sights and maintaining his position for about two seconds after operating the trigger. This follow through of the shot is intended to eliminate any movement of the rifle caused by the firer relaxing or raising his head before the bullet has left the muzzle.
- b. Declaration. As the shot is fired, the recoil action causes the muzzle of the rifle to move, usually in an upward direction. This movement should be consistent for successive shots. When a different movement occurs it may well be

sive shots. When a different movement occurs it may well be found that this particular shot is displaced from the remainder of the group. After all shots, particularly during training, the firer must watch for the movement of his sights during the follow through, and immediately declare the shot **CORRECT** or **INCORRECT** to his coach. If all is as the firer intended, then his declaration should be **CORRECT**. An **INCORRECT** declaration should be made if, for example, the aim at the moment of squeezing the trigger was not as intended, or the movement of the sights during the follow through was inconsistent with previous movement, or anything occurs that the firer did not intend. After an incorrect declaration when live firing the firer and coach should discuss the fault and its correction.

7. **Confirm by Practice.**

8. **Conclusion**

- a. Take questions from the class on the entire lesson.
- b. Confirm by questions and practice.
- c. Conduct safety precautions.
- d. Pack kit.
- e. Summary. To include the following:
 - (1) the importance of testing and adjusting the position;
 - (2) restraint of breathing when a shot is fired;
 - (3) the need to follow through;
 - (4) the importance of declaration, particularly in training; and
 - (5) a forecast of the next lesson in this subject.

LESSON 6 - FIRING DRILLS

216. GRAPHICS



Figure 2-22 Prone Alert Position

217. INSTRUCTOR'S NOTES

1. Aim. To teach:
 - a. orders during firing,
 - b. the Alert positions,
 - c. types of fire, and
 - d. rates of fire.
2. Timings. Two 40-minute periods.
3. Method. A basic instructional period for outdoors but can be successfully taught indoors.
4. Stores
 - a. Rifles 1 per soldier
 - b. Eye discs 1 per soldier
 - c. Figure or representative targets 2 per soldier
 - d. Groundsheets 1 per soldier
(for outdoor period)

5. Preparation

- a. Ensure all sights are secure and undamaged.
- b. If the period is to be taken outdoors every soldier lays down a ground sheet as a dry and marked base on which to work.

6. Miscellaneous

- a. Empty magazines are to be used in lieu of filled magazines.
- b. After the initial practice, subsequent practice can be made more realistic by dividing the class into groups of two and using eye discs.

CAUTION

DUMMY ROUNDS ARE NOT TO BE USED WHEN PRACTISING AGAINST LIVE TARGETS OR WHEN EYE DISCS ARE IN USE.

- c. During confirmation by practice of snaphooting, give the commands UP and DOWN to signify target exposures. Start off with a time limit of four seconds per shot reducing the time limit according to progress. Occasionally order MISS so that the soldier has to fire a second shot.
- d. During confirmation by practice of rapid fire, start off at a rate of five rounds in 30 seconds. Increase the number of rounds or vary the time according to progress.
- e. During final practice divide the class into groups and practise them in all types of firing.

218. CONDUCT OF THE LESSON

1. Safety Precautions. Normal.
2. Review.

- a. Holding and aiming.
- b. Firing in the prone position.

3. **Introduction.** Explain that a soldier is required to produce different types of fire on orders from his section commander, or on his own initiative. He must be familiar with these types of fire and when to use them in order to apply effective fire against the enemy with the minimum waste of time and ammunition.

4. **Orders During Firing.** Explain and demonstrate:

- a. Upon receipt of a fire order the sights and then the selector lever are set accordingly. Fire at the ordered rate of fire.
- b. On the order **STOP** cease firing and set the selector lever at 'S'. Await further fire orders.
- c. On the order **GO ON** continue firing at the same target at the same rate.

5. **Types of Fire.** Explain that there are four types of fire used in battle.

- a. Rapid Fire. Rapid fire is used to win the fire fight or when the enemy are assaulting our position. Its use must be carefully controlled to conserve ammunition. With practice up to 20 aimed shots per minute at different targets can be achieved.
- b. Deliberate. Deliberate fire is a much slower rate of fire not normally more than five rounds per minute. It is generally ordered after the fire fight has been won in order to prevent the enemy returning aimed fire, observing or moving.

- c. Snapshotting. Snapshotting is intermittent, opportunity shooting at enemy who expose themselves for short periods.
 - d. Automatic Fire. Automatic fire is normally only used in close quarter battle particularly during the final stages of an ambush, when repelling a mass attack or in house clearing. Ammunition availability will govern the rate of fire on most occasions.
6. **Deliberate Fire**. Explain and demonstrate. Order **LOAD - DOWN - RANGE 200** or give a fire order. Adopt the alert position and indicate a target.
- a. When the target has been indicated put the selector lever to 'R', aim, test and adjust as previously taught.
 - b. On the command **FIRE**, control the breathing, perfect the aim, fire and follow through. In training declare the shot.
 - c. Lower the muzzle and observe the target area.
 - d. Continue firing at the deliberate rate; keep a count of the number of rounds left in the magazine and change it when necessary.
 - e. On the command **STOP**, put the selector lever to 'S', if necessary change magazines, and await further orders.
 - f. On the command **GO ON**, put selector lever to 'R' and continue firing.
7. **Confirm by practice**. Order **STOP - MAKE SAFE**.
8. **Snapshotting**. Explain that firing at targets which show themselves for short periods only is called snapshotting. Snapshotting is similar to deliberate shooting except that the soldier speeds up his actions and reduces the interval between shots, usually firing two shots

during breath restraint. There may be less time for correct breath restraint, but the principles must be followed as closely as possible.

9. Alert Position. The alert position is adopted on the command WATCH AND SHOOT and is a good position to adopt when expecting the enemy to appear. It is an easy position to maintain while the soldier is observing his arc. There may be occasions when the indication is such that the soldier may observe through the sights. To adopt the alert position, push the selector lever to 'R', bring the butt into the shoulder with the muzzle pointing downwards and watch the target area, see Figure 2-22.

10. Explain and Demonstrate. Order DOWN - RANGE 200, or give a fire order.

- a. On the command WATCH AND SHOOT adopt the alert position.
- b. When a target appears, restrain the breathing, aim and fire quickly but with accuracy.
- c. Continue to fire until the target falls or goes to cover; stop firing, continue to observe the target area through the sights and be ready to fire again.
- d. Actions on the command STOP - GO ON and the need for counting rounds are as in deliberate fire.

11. Confirm by Practice. Order STOP - MAKE SAFE.

12. Rapid Firing. Explain, that firing a number of quick shots in succession is called rapid fire. It is similar to snapshooting, except that the soldier may fire more rounds. With practice, he will be able to fire 20 or more accurate shots at different targets in a minute.

13. Explain and Demonstrate. Order DOWN - RANGE 100. Adopt the alert position and indicate a target.

- a. On the command **RAPID**, put the selector lever to 'R', aim and watch the target area.
 - b. On the command **FIRE**, fire as quickly as possible with accuracy. Change to a fresh target as each one falls.
 - c. It is important in rapid fire to try and fire with rhythm. This will enable breath restraint, aim perfection, trigger operation and follow through to be performed in their correct sequence. Alternatives to breath restraint as previously taught are:
 - (1) Very shallow breathing between shots for the periods of rapid fire.
 - (2) Breath restraint covering the release of two or three shots provided that it does not cause strain.
 - d. Adjust the position for each target being engaged and go on firing until there are no more targets at which to fire.
 - e. Actions on the commands **STOP - GO ON** and the need for counting rounds, are the same as in deliberate fire.
14. Confirm by Practice. Order **STOP - MAKE SAFE**.
15. Automatic Fire. Explain that when this type of fire is required the order will be **BURSTS - RAPID - FIRE**. On hearing **BURSTS** the change lever is set to **AUTO**. On **FIRE**, fire as quickly as possible in bursts of two to three rounds while maintaining accuracy. To allow the chamber to cool during lulls in rapid fire, cock the rifle, engage the bolt catch and open the ejection port cover. If time permits, replace the round in the magazine. To get ready to fire again, release the bolt catch.
16. Rates of Fire. Explain that there are two rates of fire possible with the C7.

a. Repetition -

- (1) 30 rounds per minute for several minutes (normal), and
- (2) 15 rounds per minute (sustained).

b. Automatic -

- (1) 60 to 90 rounds per minute for a few minutes.

17. Confirm by Questions.

18. Conclusion

a. Take questions from the class on the entire lesson.

b. Confirm by questions and practice.

c. Conduct safety precautions.

d. Pack kit.

e. Summary. To include the following:

- (1) the importance of applying the sequence of firing a shot to all types of firing; and
- (2) a forecast of the next lesson in this subject.

LESSON 7 - FIRING FROM OTHER POSITIONS

219. GRAPHICS



Figure 2-23 Kneeling Position



Figure 2-24 Kneeling - Alert Position



Figure 2-25 Sitting Position



Figure 2-26 Sitting Alert Position



Figure 2-27 Standing Position



Figure 2-28 Squatting Position

220. INSTRUCTOR'S NOTES

1. Aim. To teach how to fire from the kneeling, sitting, standing and squatting positions, and the alert position as applied in each.
2. Timings. Two 40-minute periods.
3. Method. A basic instructional period best suited to a dry training area outdoors.
4. Stores
 - a. Rifles 1 per soldier
 - b. Eye discs 1 per soldier
 - c. Figure targets 6 (various)
5. Preparation
 - a. Reconnoitre the dry training area and note locations for targets.
 - b. Position targets at various ranges up to a maximum of 200 metres.
6. Miscellaneous
 - a. As the positions being taught are less stable than the prone position, it is impossible to hold the rifle perfectly still when aiming. An area aim on the target as opposed to a point has to be accepted. The size of the area aim will depend on the stability of the position being used and the time available to fire the shot. This will decrease in size with practice as the soldier's shooting muscles develop and his reflex actions speed up.
 - b. Additional information on all positions is contained in B-GL-318-006/PT-002 Shoot-to-Live, Part 2, Marksmanship Theory and Coaching.

221. CONDUCT OF THE LESSON

1. Safety Precautions. Normal.
2. Review. Firing in the prone position.
3. Introduction. Explain that under operational conditions or on a field firing range it is often impossible to engage targets from the prone position. The soldier, therefore, must learn to adopt either the kneeling, sitting, squatting or standing position, according to the nature of the ground and the target. With practice, it is possible to make an immediate decision as to which is the most suitable in each instance. When a decision is made, the position is to be adopted quickly; whatever the position adopted, the actions on receiving orders, **READY**, are the same as for the prone position.
4. Kneeling Position. See Figure 2-23. Explain and demonstrate with the class imitating.
 - a. Face half right to the line of fire. Kneel on the right knee, keeping it well out to the right and, if possible, sit on the heel or the side of the foot. Rest the left forearm behind or in front of the left knee and the butt on the right thigh.
 - b. On a range being ordered set the sight, cock the weapon and put the selector lever on 'S'.
 - c. On the command **WATCH AND SHOOT**, adopt the alert position, bring the butt into the shoulder and move the selector lever to 'R', see Figure 2-24. The left foot is turned inwards to lock the lower part of the foot and reduce movement. The left knee is under the rifle and the butt is higher in the shoulder than in the prone position. The weight of the body is taken over the right heel.

- d. The sequence and drill for firing the shot are as taught for the prone position.
5. **Confirm by Practice.**
6. **Sitting Position.** See Figure 2-25. Explain and demonstrate with the class imitating.
 - a. The sitting position is useful when firing from a forward slope, in low scrub, in a night ambush or at moving targets at short ranges.
 - b. Sit with the legs crossed or apart and place the feet in a comfortable position. The rifle is held as in the kneeling position.
 - c. On a range being ordered set the sight, cock the weapon and put the selector lever on 'S'.
 - d. On the command WATCH AND SHOOT, adopt the alert position, bring the butt into the shoulder and move the selector lever to 'R', see Figure 2-26. Place the elbows in front of or on the inside of the knees.
 - e. The sequence and drills for firing the shot is as taught for the prone position.
7. **Confirm by Practice.**
8. **Standing Position.** See Figure 2-27. Explain and demonstrate with the class imitating.
 - a. The standing position is used primarily when firing from behind high cover, in a trench, or during an advance to contact when targets are engaged quickly.
 - b. Adopt the standing load position.
 - c. On a range being ordered set the sight, cock the weapon and put the selector on 'S'.

- d. On the command WATCH AND SHOOT, adopt the alert position, bring the butt into the shoulder and move the selector lever to 'R', muzzle pointing forward and down.
 - e. The handguard is held and the body leans slightly forward in the direction of the target.
 - f. The sequence and drills for firing the shot are as taught for the prone position.
9. Confirm by Practice.
10. Squatting Position. See Figure 2-48. Explain and demonstrate with the class imitating.
- a. The squatting position is useful for firing from mud, shallow water and in open country where other firing positions may not easily be adopted.
 - b. Some difficulty may be experienced in adopting the position but continued practice will enable the firer to adapt the position to suit his build.
 - c. To use the squatting position halt with the feet about 100-400 mm apart and drop down onto the haunches into a natural squatting position.
 - d. The body is to be about 535 mils (30°) to the line of fire. The left foot may point at the target.
 - e. The backs of the thighs rest against the back of the calves. Allow the knees to bend to their full extent. Any tension in the thighs will cause undue strain to the calf muscles.
 - f. Adjustments for direction onto the target are quickly and easily achieved by moving the right foot either to the left front or right rear.

- g. Muscle relaxation in the legs is most important in this position and therefore some experimentation may be found necessary to suit individual firers. Adjustment of the position could entail raising the right heel slightly from the ground or both heels, ensuring the weight is evenly distributed on the ball of the feet. Some firers may prefer the inside of the right foot to be flat on the ground.
- h. The sequence and drills for firing a shot is as taught for the prone position.

11. Confirm by Practice.

12. Conclusion

- a. Take questions from the class on the entire lesson.
- b. Confirm by questions and practice.
- c. Conduct safety precautions.
- d. Pack Kit.
- e. Summary. To include the following:
 - (1) no matter which position is adopted in relation to available cover, the four marksmanship principles are to be applied;
 - (2) a change of firing position can affect accuracy; and
 - (3) a forecast of the next lesson in this subject.

LESSON 8 - MECHANISM, IMMEDIATE ACTION AND POSSIBLE STOPPAGES

222. GRAPHICS

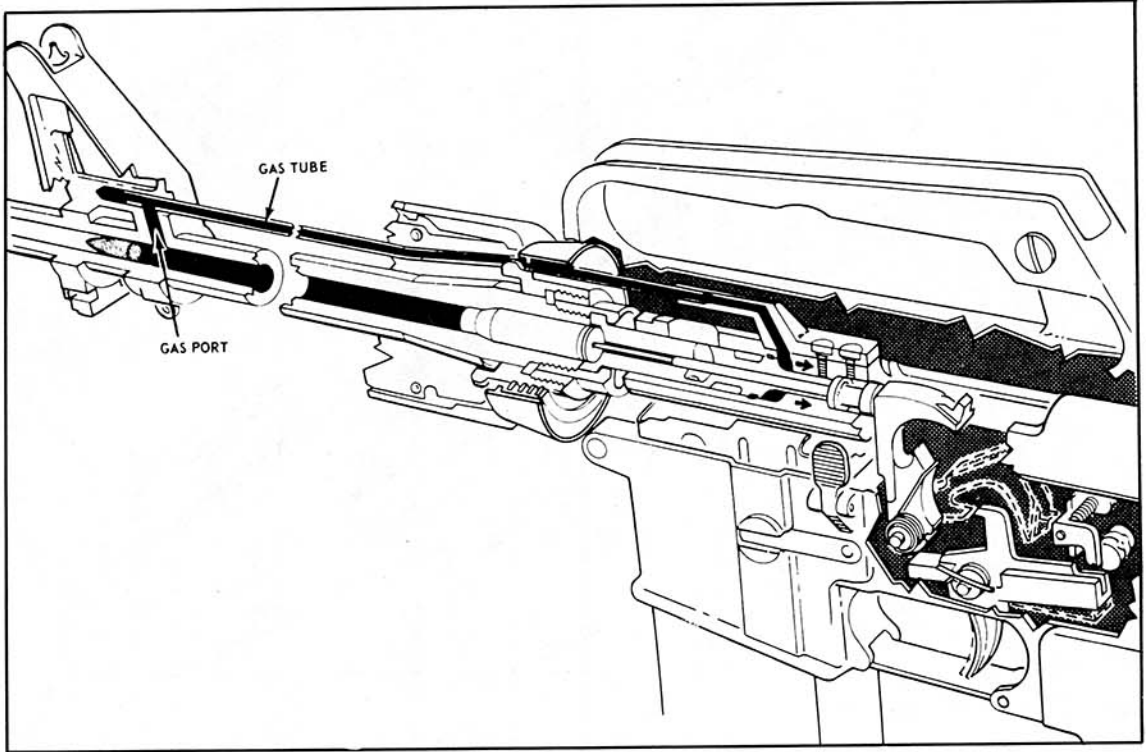

Figure 2-29 Firing

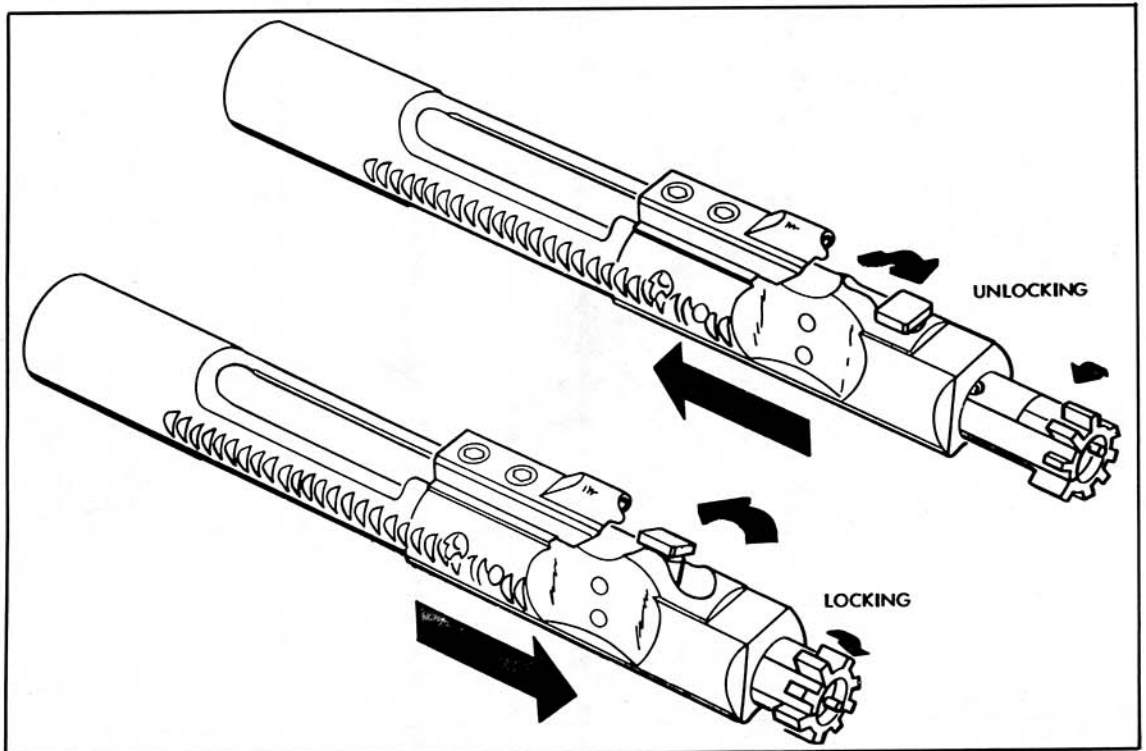

Figure 2-30 Bolt Locking and Unlocking

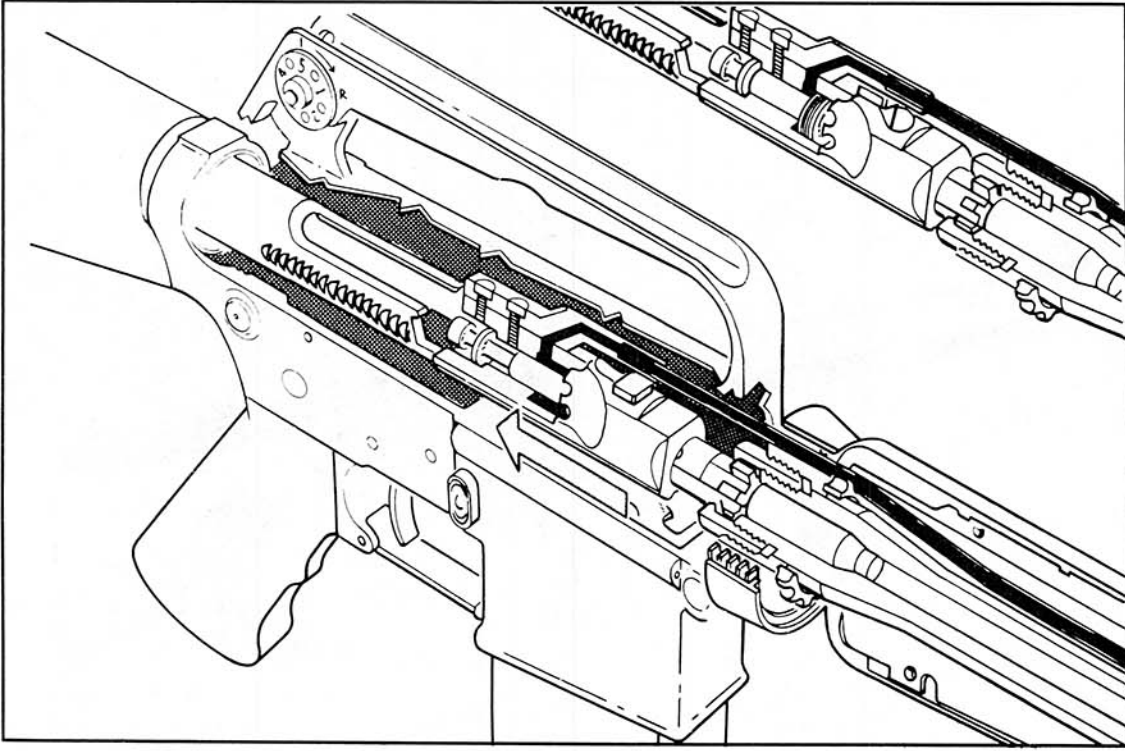

Figure 2-31 Extracting

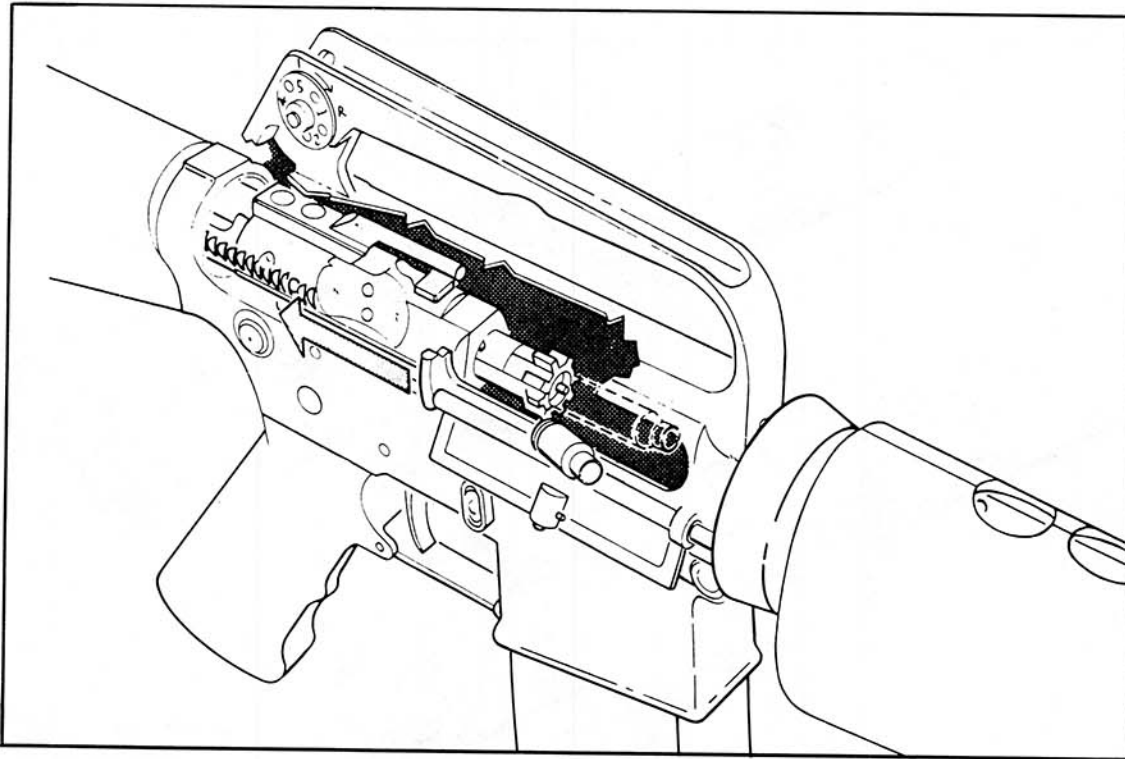

Figure 2-32 Ejecting

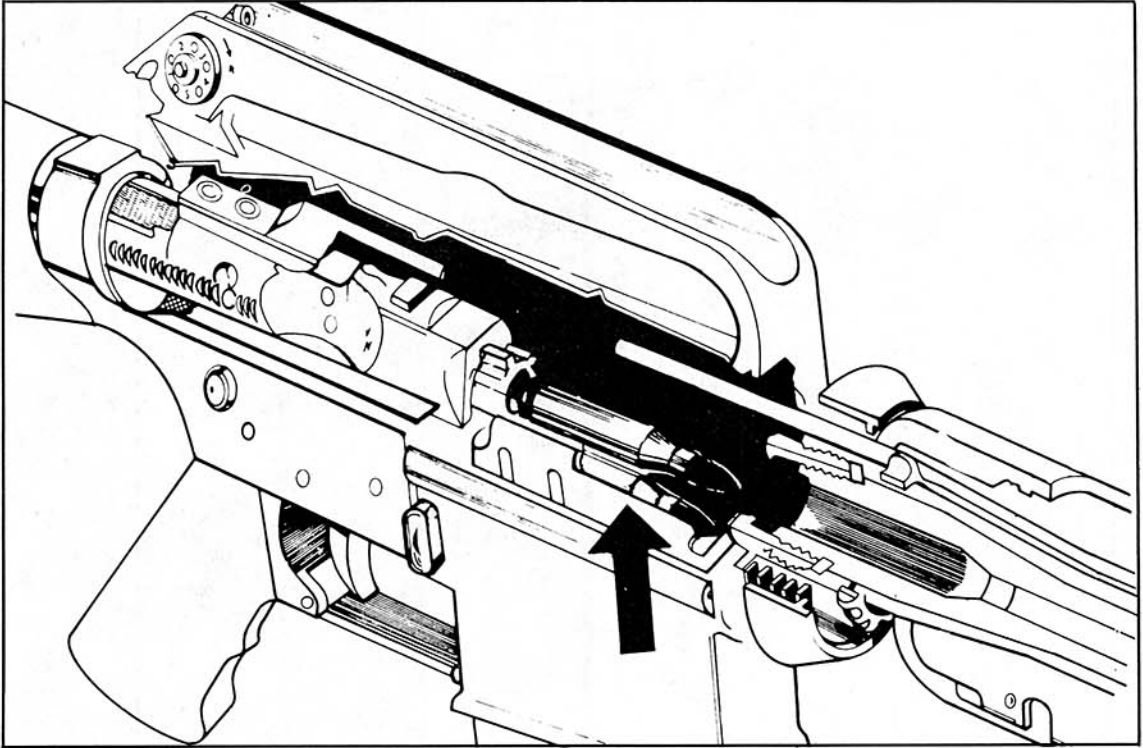

Figure 2-33 Feeding

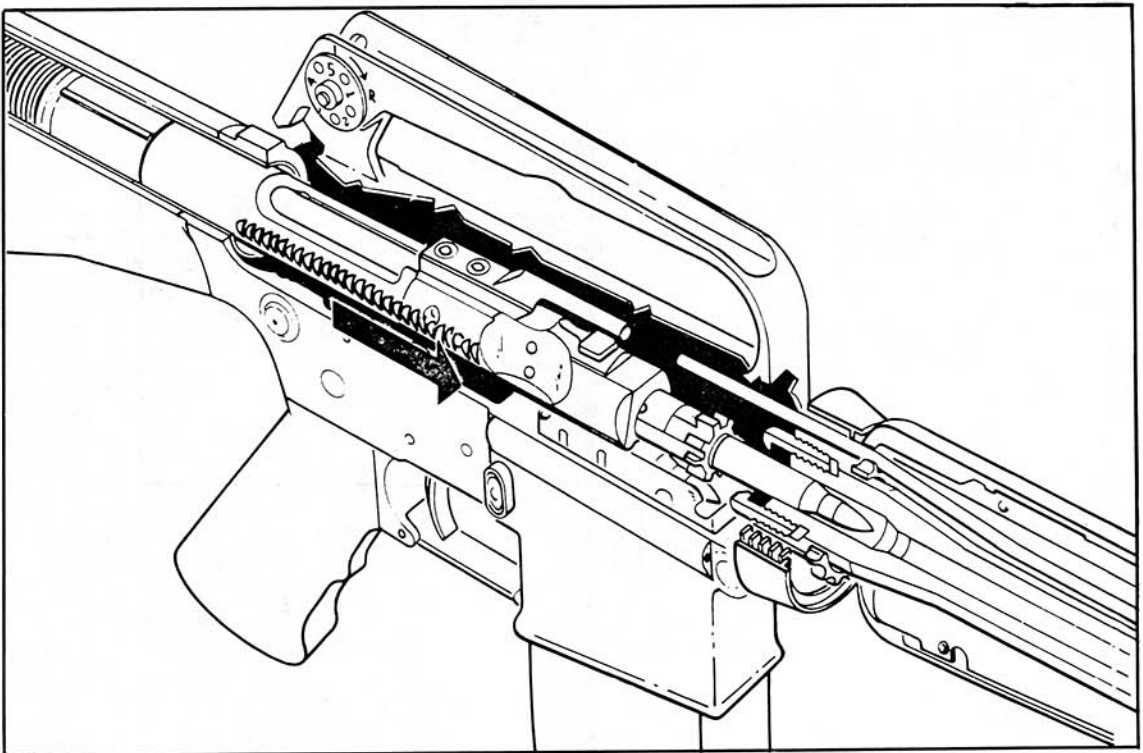

Figure 2-34 Chambering

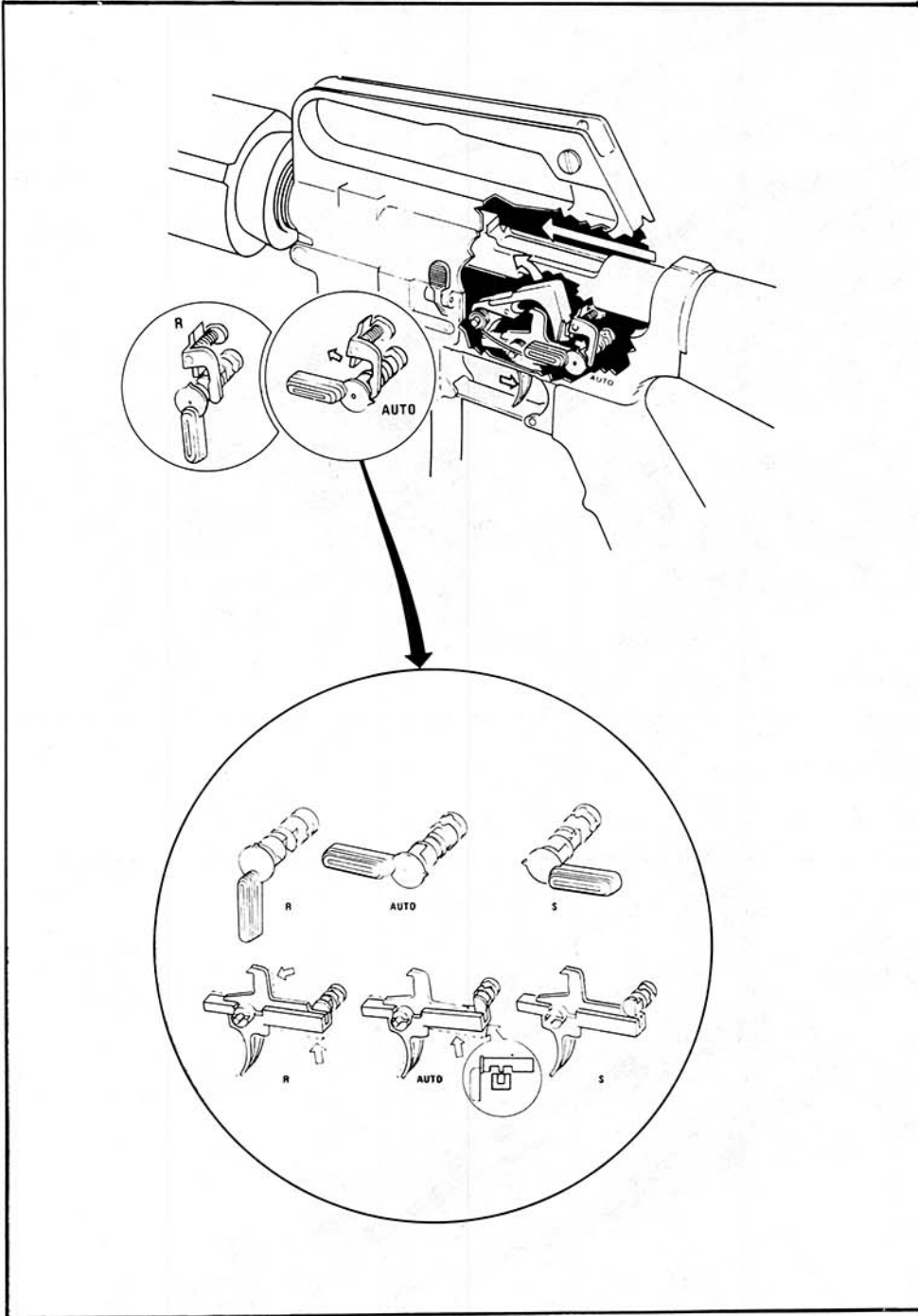

Figure 2-35 Selector Lever Action

223. INSTRUCTOR'S NOTES

1. Aim. To teach:
 - a. how the rifle operates,
 - b. the reason for stoppages, and
 - c. the prevention and remedies for stoppages.
2. Timings. Two 40-minute periods.
3. Method. A basic instructional period.
4. Stores
 - a. Rifles 1 per soldier
 - b. Dummy rounds 20 per soldier
 - c. Targets 1 per soldier
 - d. Video of mechanism
 - e. Video of immediate action
5. Preparation
 - a. Ensure dummy rounds are not damaged.
 - b. The class is to LOAD with a 30 round magazine and MAKE SAFE before the mechanism stage.
6. Miscellaneous
 - a. Allow the class to use their own rifles to aid any explanation during the confirmation stage of the basic mechanism.
 - b. To allow the working parts to go forward when the rifle is cocked during the stoppage drill stage of the lesson, it is necessary to load with a stripped magazine (remove the spring and magazine platform).
 - c. Individuals are to aim and fire on completion of any stoppage drill.

- d. During the practice stage of stoppages the instructor is to indicate the position of the working parts, ie, **FULLY FORWARD, REAR, NOT FULLY FORWARD**. When the soldier examines the magazine and/or chamber he must be told its condition.

224. CONDUCT OF THE LESSON

1. Safety Precautions. Normal.
2. Review. None.
3. Introduction. Explain that it is necessary to understand how the rifle works and why stoppages occur. In this way the soldier is better equipped to remedy stoppages and get the rifle firing again as soon as possible.
4. Basic Mechanism. Explain and demonstrate with the class imitating.
 - a. When the trigger is squeezed the hammer strikes the rear of the firing pin and drives it forward onto the cap in the base of the round. The round goes off and forms gas which drives the bullet up the barrel, see Figure 2-29.
 - b. When the bullet has passed the gas vent some of the gas goes through the vent and into the gas tube. It then passes through the tube into the gas cylinder of the bolt carrier and drives it to the rear.
 - c. As the carrier moves rearwards it causes the bolt to rotate and unlock from the firing position, see Figure 2-30. The carrier and bolt go back together, cocking the hammer as they go. The extractor pulls the empty case with it until the case is freed from the chamber, see Figure 2-31. The ejector then forces it from the face of the bolt out through the ejection opening, see Figure 2-32. The rear of the carrier goes through a hole in the butt and compresses the return spring.

d. The return spring forces the bolt and carrier forward. As it does so the front of the bolt pushes a round from the magazine into the chamber, see Figures 2-33 and 2-34. When the bolt has gone right forward the carrier continues causing the bolt to rotate and lock in position. The extractor grips the base of the round and the ejector is compressed when the bolt is fully home.

5. Confirm by Questions.

6. Selector Lever See Figure 2-35. The rifle may be fired when the selector lever, located on the left side of the lower receiver, is set to either 'R' or 'AUTO'.

a. 'R' (Repetition). When the selector lever is in the 'R' position a disconnect is used to catch and hold the hammer until the trigger is released and squeezed a second time. When the trigger is squeezed, the disconnect is rotated forward by the action of the disconnect spring. As the hammer is cocked by the recoil action of the carrier group, the hook of the disconnect engages the upper inside notch of the hammer, holding it to the rear. When the trigger is released, the trigger spring returns the trigger to its normal position which rotates the disconnect back releasing the hammer from the hook on the disconnect. Before the disconnect releases the hammer the trigger sear surface has moved in front of its hammer notch so that the hammer drops from the disconnect sear to the trigger sear. The rifle is then ready for the next shot.

b. 'AUTO' (Automatic). When the selector lever is set on 'AUTO' and the trigger is squeezed, the trigger sear

releases the hammer. The disconnecter is prevented from moving forward to engage the hammer by a cam on the selector lever. After the first shot, as the hammer is being cocked by the recoil action of the carrier group, the notch on the top outside edge of the hammer is engaged by the automatic sear. The hammer is then held in the cocked position by the automatic sear until the bolt carrier strikes the upper edge of the automatic sear in counter-recoil, causing it to release the hammer near the end of the forward travel of the carrier. The hammer then falls to fire the next round. This cycle repeats until the magazine is emptied or the trigger is released. When the trigger is released, the hammer falls from the automatic sear but is held by the trigger sear, thus ending the cycle of automatic fire.

7. **Confirm by Questions.** Unload and empty magazines. Place a stripped magazine on the weapon.

8. **Immediate Action.** Explain and demonstrate with the class imitating. If the rifle fails to fire or stops firing the immediate action is to cant the rifle to the left and look in the ejection port at the position of the bolt.

a. If the bolt is at the rear:

- (1) check for an empty magazine and load,
- (2) cock the rifle and strike the forward assist assembly,
and
- (3) resume firing.

b. If the bolt is fully forward:

- (1) tap the magazine to ensure it is fully seated and
locked in place,

- (2) strike the forward assist assembly to ensure the bolt and carrier are fully forward,
- (3) cock the rifle and watch for the ejection of a round or empty casing,
- (4) if a round or empty casing is ejected strike the forward assist assembly, and
- (5) aim and carry on firing.

c. If the bolt carrier is partially forward:

- (1) check for a round caught in the receiver or chamber,
- (2) remove the magazine,
- (3) clear the obstructing round by cocking the action,
- (4) load,
- (5) cock the rifle and strike the forward assist assembly, and
- (6) resume firing.

9. **Confirm by Practice.** The instructor must indicate the position of the bolt and carrier and the condition of the magazine and chamber.

10. **Further Action.** Explain that if after carrying out the immediate action the rifle still fails to fire and the bolt is fully forward the cause is probably excessive fouling, or broken or damaged parts. Unload, strip the rifle and examine it, clean the affected parts. A weapons technician is to replace damaged or broken parts.

11. **Gas Affected Parts.** Explain that it is essential that the gas receiver and the rear of the gas tube are cleaned regularly. If this is not done, there is a possibility that these two parts may become fused together with a round in the chamber. This will mean either that the

weapon will not cock after firing the first round or that the round in the chamber cannot be unloaded by cocking. As soon as possible strip the rifle and clean the gas affected parts.

12. In battle it may be a worthwhile risk to clear the rifle by pointing in a safe direction, removing the magazine and firing the round in the chamber.

13. Confirm by Questions and Practice.

14. Conclusion

- a. Take questions from the class on the entire lesson.
- b. Confirm by questions and practice.
- c. Conduct safety precautions.
- d. Pack kit.
- e. Summary. To include the following:
 - (1) requirement to understand the rifle mechanism; and
 - (2) the importance of regular care and maintenance in order to prevent stoppages.

LESSON 9 - ALTERATION OF POINT OF AIM,
WIND ALLOWANCE AND MISS DRILL

225. INSTRUCTOR'S NOTES

1. Aim. To teach:
 - a. how to correct errors by altering the point of aim;
 - b. the allowances to make for different types of wind; and
 - c. the correct drill to carry out on missing the target.
2. Timings. A 40-minute period.
3. Method. A basic instructional period best taught immediately prior to firing Range Practice 5 - Elementary Application.
4. Stores
 - a. Rifles 1 per soldier
 - b. Targets: 1 Figure 11
1 Figure 12
 - c. Aim picture (see Figure 2-20) 1 per soldier
5. Preparation
 - a. Issue aim pictures.
 - b. Examine all sights.
6. Miscellaneous
 - a. The wind allowances to be taught provide the soldier with simple to follow rules which will increase the probability of a first round hit in battle.
 - b. Instructors are to use the aim pictures to confirm sight alignment on to the different POA.

226. CONDUCT OF THE LESSON

1. Safety Precautions. Normal.
2. Review. Nil.
3. Introduction. Explain that in battle or during rangework, the strength and direction of the wind have a direct influence on the flight path of the bullet. It is essential that the soldier makes allowances to counter this influence and ensure a first round hit. It is also important to know how to react should the shot miss the target.
4. Range Targets. Explain that Figure 11 targets are 1145 mm (45 inches) high and 450 mm (18 inches) wide and Figure 12 targets are 570 mm (22 inches) high and 450 mm (18 inches) wide. The areas 150 mm (6 inches), 300 mm (12 inches) and 450 mm (18 inches) above and below the POA on a Figure 11 target are easily identified at longer ranges and are useful aids when altering points of aim.
5. Aiming Off For Elevation and Direction. Explain that errors in elevation and direction can be overcome by changing the point of aim. If, from the POA, the shot is seen to be high (300 mm) and to the left (100 mm), re-aim low (300 mm) and right (100 mm) of the original POA.
6. When firing at small targets at ranges of about 200 metres or less, aim at the bottom of the target.
7. Confirm by Practice.
8. Aiming Off for Wind. Explain that only a wind blowing across the front will make the bullet veer considerably from its flight path. To allow for this aim off into the wind; the direction of the wind can be determined by its effect on the face, trees, dust, smoke, etc. The amount to aim off is determined by the strength of the wind.

- a. A fresh wind has an appreciable effect on bushes and thin branches of trees and can be distinctly felt on the side of the face. It would cause range flags to stand about halfway out from the pole.
 - b. A strong wind has a noticeable effect on tree tops and lifts dust off dry ground. Range flags would tend to strain away from their poles.
9. For battle shooting, two points of aim are used at ranges over 100 metres:
- a. Freshwind: POA is halfway between the centre and edge of the target.
 - b. Strong Wind: POA is the edge of the target.
10. Confirm by Practice.
11. Miss Drill. Explain that in the event of continually missing a target:
- a. Increase the aim off to the edge of the target and fire.
 - b. If still a miss, aim and fire at the base of the target and adjust the POA from the observation of strike.
 - c. Ensure that sight alignment is correct for the adjusted POA.
12. Confirm by Practice.
13. Conclusion
- a. Take questions from the class on the entire lesson.
 - b. Confirm by questions and practice.
 - c. Conduct safety precautions.
 - d. Pack kit.
 - e. Summary. To include the following:
 - (1) the importance of aiming off for wind and applying the miss drill; and
 - (2) a forecast of the next lesson in this subject.

LESSON 10 - CLOSE QUARTER BATTLE

227. GRAPHICS



Figure 2-36 High Port



Figure 2-37 Alert Position



Figure 2-38 Cradle Carry



Figure 2-39 Low Port

228. INSTRUCTOR'S NOTES

1. Aim. To teach the methods of carrying the rifle and how to fire at close quarters.
2. Timings. One 40-minute period.
3. Method. A basic instructional period.
4. Stores
 - a. Rifles with slings fitted 1 per soldier
 - b. Bayonets 1 per soldier
 - c. Targets 3 Figure 11
3 Figure 12
 - d. Fragmentation Vest 1 per soldier

5. Preparation

- a. Reconnoitre the dry training area and note locations for targets.
- b. Put out targets at various ranges up to 50 metres.

6. Miscellaneous

- a. After the review prepare to fire with bayonets fixed.
- b. During the final confirmation by practice, use soldiers as live targets, having them suddenly appearing from different directions and then disappearing.
- c. The High Port, Alert and Low Port are firing positions to maintain for extended periods. The Cradle Carry provides a 'semi-alert' position which can be maintained for longer periods as the butt is supported on the forearm. The delay in bringing the butt into the aim from this position is only fractionally longer than from the alert position. As the butt is placed outside the elbow, it enables the soldier wearing a fragmentation vest to bring it directly into the shoulder, without extending the arms to avoid the configuration of the vest.
- d. If available, fragmentation vests should be worn during the period.

229. CONDUCT OF THE LESSON

1. Safety Precautions. Normal.
2. Review

- a. The standing alert position.
- b. The standing position for quick shooting.

3. **Introduction.** Explain that when moving in close country, on patrol or in a built-up area, the enemy may fire and attack at close quarters. In such situations, it is the quickness and accuracy of the first shots which gain success. The soldier is, therefore, to carry his rifle in a state of readiness and in a manner best-suited to the type of terrain over which he is moving.
4. **High Port.** See Figure 2-36. Explain and demonstrate with the class imitating.
 - a. Bring the rifle up across the body, left hand on the hand-guard, right hand around the pistol grip and the barrel pointing upwards.
 - b. Move the selector lever to 'R' and place the finger on the trigger.
 - c. This position is used when going through scrub or when crossing obstacles. If the soldier stumbles using this position, the muzzle of the rifle will not get entangled, get filled with dirt or point at his comrades.
 - d. The soldier is responsible for the safe handling of his rifle and is to move the selector lever to 'S' when necessary.
5. **Confirm by Questions and Practice.**
6. **Alert Position.** See Figure 2-37. Explain.
 - a. The position is as previously taught.
 - b. The soldier is responsible for the safe handling of his rifle and is to move the selector lever to 'S' when necessary, eg, when crossing an obstacle.

7. **Cradle Carry.** See Figure 2-38. Explain and demonstrate with the class imitating.
 - a. The cradle carry provides an alternative to the alert position when a fragmentation vest is being worn.
 - b. Hold the rifle as for the alert position but allow the butt to rest outside the front of the right arm with the butt weight cradled in the elbow.
8. **Low Port.** See Figure 2-39. Explain and demonstrate with the class imitating.
 - a. The low port position is used when the tactical situation does not necessitate the use of the high port or alert positions, in particular, on internal security operations when one hand is required for searching personnel, checking documents or moving barriers.
 - b. Hold the rifle by the pistol grip, finger outside the trigger guard, selector lever at 'S', the barrel pointing upwards and the heel of the butt resting on the waist belt.
9. **Close Quarter Shooting.** Explain and demonstrate with the class imitating.
 - a. To fire from the high port, alert or low port position, ensure that the selector lever is at 'R', adopt the standing, kneeling, squatting or sitting firing position and continue to fire until the enemy is killed.
 - b. When moving in the advance or on patrol, etc, soldiers are to halt momentarily to aim and fire. It should be remembered that accuracy is affected when firing with the bayonet fixed and that it is necessary to aim slightly low at close range targets.

c. The ideal is to hit with the first shot. However, two or more shots in rapid succession, ie, "double taps" will improve the chances of a kill.

10. **Confirm by Practice.**

11. **Conclusion**

- a. Take questions from the class on the entire lesson.
- b. Confirm by questions and practice.
- c. Conduct safety precautions.
- d. Pack kit.
- e. Summary. To include the following:
 - (1) the importance of speed and accuracy in firing; and
 - (2) a forecast of the next lesson in this subject.

LESSON 11 - FIRING AT CROSSING TARGETS

230. INSTRUCTOR'S NOTES

1. Aim. To teach the allowances which have to be made for crossing targets and the methods used to apply them.

2. Timings. One 40-minute period.

3. Method. A basic instructional period best programmed to a range day as a preliminary to live firing Range Practice 8.

4. Stores

- | | |
|-----------------------------|---------------|
| a. Rifles | 1 per soldier |
| b. Figure targets on stakes | 1 Figure 20 |
| c. Aim diagrams | 1 per soldier |

5. Preparation. Construct aim diagrams with a representative Figure 20 target and a moveable pointer/front sight.

6. Miscellaneous

a. Targets. Use Figure 20 targets. When Figure 11 targets are used in lieu they should be trimmed to a width of 280 mm (11 inches) to ensure that correct allowances are learned and practised.

b. Preliminaries. Order LOAD, RANGE 100, and stand the class at ease after normal precautions.

c. Crossing Target Allowances. Confirm the allowances to be made by asking questions and let the class use diagrams to illustrate their answers.

d. Methods of Engaging Crossing Targets

(1) Use the standing position during demonstrations.

Produce the swinging action from the knees and plevis.

(2) For practice, order a range, nominate the firing position to be adopted and start each practice from the ALERT position. Use each soldier of the class in turn to walk/run across the previously set out ten metre area.

(3) Allow the soldiers to practice the basic method from different firing positions.

e. Firing. As soon as possible after instruction, soldiers are to fire Range Practice 8.

231. CONDUCT OF THE LESSON

1. Safety Precautions. Normal.

2. Review. Nil.

3. Introduction. Explain that most shots fired under operational conditions will be against moving targets, some of which will be crossing the front. The standing or kneeling position will be used frequently in close country and urban areas, during the advance and in attack or mopping up. It is important that all soldiers know what allowances to make for target movement and the techniques used to apply them in any firing position. It is also important that the soldier understands that frequent practice is required to achieve and maintain a high degree of skill in engaging moving targets.

4. Crossing Target Allowance. Explain.

a. When a shot is fired at a moving target, the target continues to move during the time of flight of the bullet. To allow for this movement it is necessary to aim in front of the target otherwise shots will fall behind it. This aiming in front, to anticipate the movement of the target, is known as LEAD.

- b. The amount of lead necessary will depend on the speed, range and direction of movement. A running man will require more lead than a man walking. A target moving obliquely across the front will require less lead than a direct crossing target and one moving head on or away from the firer will require no lead at all. Finally, the further the target is away the greater is the lead required to allow for its movement.
 - c. Soldiers must acquire the 'feel' for the correct lead necessary to hit moving targets under various conditions. Only by frequent practice will proficiency be achieved.
5. Confirm by Questions.
6. Methods of Engaging Direct and Oblique Crossing Targets. Explain that crossing targets are engaged by firing when the correct lead or point of aim has been taken relevant to the target. There are two methods of engaging moving targets. Explain and demonstrate.
- a. The Basic Method
 - (1) Come into the aim behind the target.
 - (2) Swing through the target to the leading edge.
 - (3) Without checking the swing, open fire and if necessary increase the lead while firing a series of shots.
 - (4) Continue firing until the target is hit or goes to ground.
 - (5) Return to the alert position.
 - b. The Ambush Method. This method is used when it is difficult to swing with the target, ie, in the prone or sitting position with both elbows rested.
 - (1) Select a POA ahead of the target.
 - (2) Come into the aim.

- (3) Commence firing prior to the target reaching the selected POA.
 - (4) Continue firing until the target is hit, goes to ground or the selected POA falls behind the target.
7. Confirm by Questions and Practice.
 8. Shotgun Technique. Explain that operational conditions may not allow the soldier time to use the sights. In this situation the 'Shotgun' technique should be used, ie, both eyes open, head well up and concentrate on the target not the barrel line. This technique can be effective up to 150 m.
 9. Confirm by Questions and Practice.
 10. Conclusion.
 - a. Take questions from the class on the entire lesson.
 - b. Confirm by questions and practice.
 - c. Conduct safety precautions.
 - d. Pack kit.
 - e. Summary. To include the following:
 - (1) the importance of quick accurate estimation of the range, angle and speed of target;
 - (2) the need for constant practice; and
 - (3) a forecast of the next lesson in this subject.

LESSON 12 - FIRING FROM COVER

232. GRAPHICS



Figure 2-40 Firing From a Trench

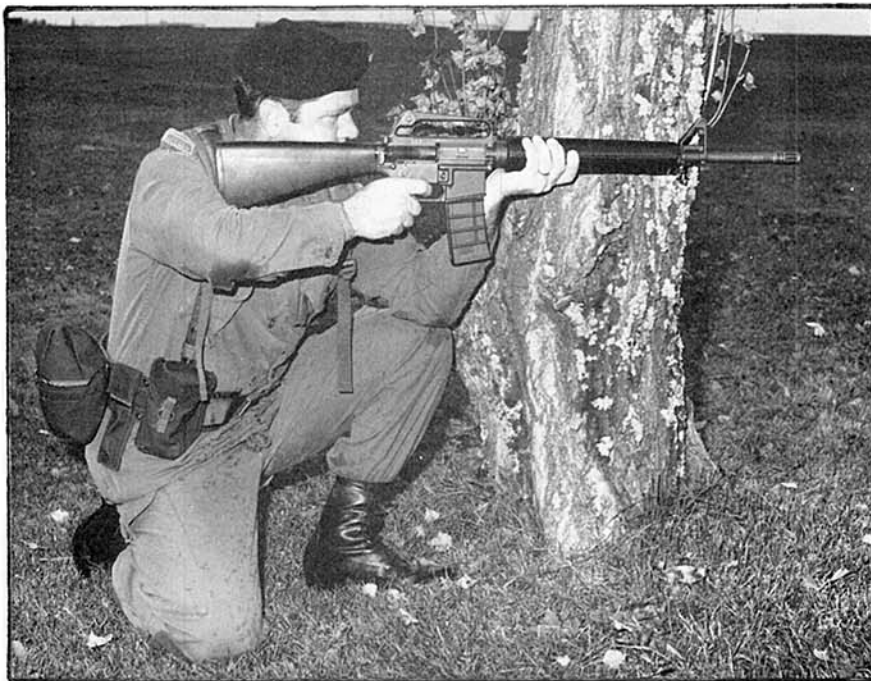

Figure 2-41 Firing Using a Post



Figure 2-42 Firing From a Corner

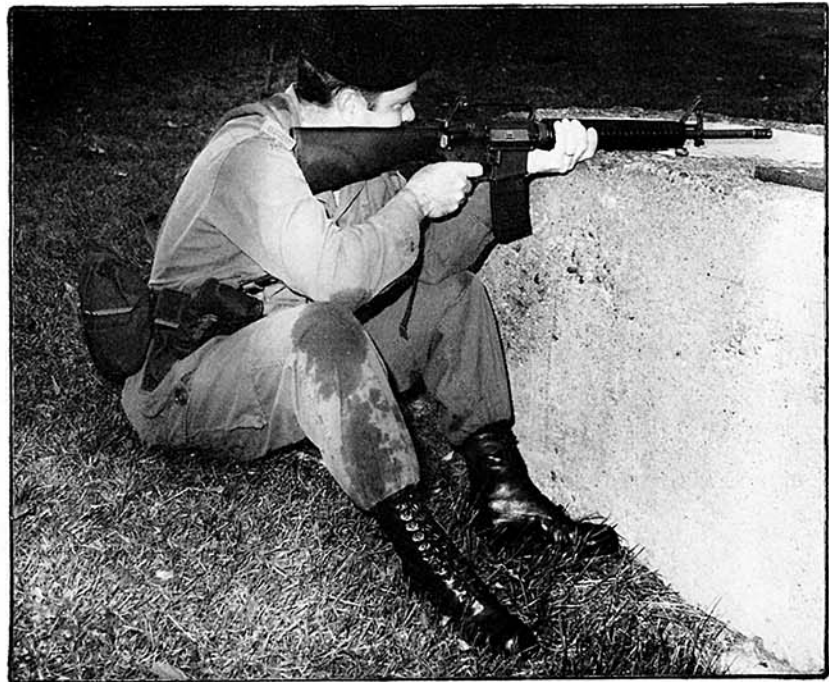

Figure 2-43 Firing Over Cover

233. INSTRUCTOR'S NOTES

1. Aim. To teach how to handle and fire a rifle from behind cover.
2. Timings. Two 40-minute periods.
3. Method. A basic outdoor instructional period best taught as a centralized demonstration followed by squad instruction and practice.
4. Stores
 - a. Rifles with slings fitted 1 per soldier
 - b. Magazines 4 per soldier
 - c. Steel Helmets 1 per soldier
 - d. Figure targets 4 (various)
5. Preparation
 - a. Reconnoitre and select ground with various types of cover such as a properly constructed fire trench, banks, ditches, bushes and trees.
 - b. Put out figure targets in suitable positions relative to the cover.
 - c. Rehearse the demonstrators.
6. Miscellaneous
 - a. Do not teach the lesson as a drill but get the soldiers to improve their positions by suggestion and reasoning.
 - b. The use of the various types of cover can be taken in any sequence.
 - c. Use demonstrators to illustrate the correct use of cover.
 - d. Show all the firing positions before practising.
 - e. Order LOAD before beginning practice.
 - f. To practise the class, give them an area in which to select fire positions and covering an allotted arc.

234. CONDUCT OF THE LESSON

1. Safety Precautions. Normal.
2. Review. Firing from other positions.
3. Introduction. Explain that in defence, fighting is normally done from a fire trench. In the attack or when patrolling, the soldier makes the best use of cover to conceal himself from view, or protect himself from enemy fire and to provide himself with a firing position.
4. Use of Cover. Explain.
 - a. Always try to rest the forearm for more accurate shooting.
 - b. When the forearm cannot be rested, rest the back of the hand on the cover. If this is not possible because the cover is too hard or has a sharp edge, then rest the rifle on the cover as close to the hand as is possible.
 - c. Do not rest the barrel as this will displace the shots fired.
 - d. No matter how the cover is used, the four marksmanship principles are to apply.
5. Fire Positions. Explain and demonstrate.
 - a. The ideal fire position is one which:
 - (1) Allows the soldier free use of his personal weapon and grenades.
 - (2) Provides cover from HE and small arms fire and also gives cover from view.
 - (3) Enables an unobstructed view of a wide arc of fire.
 - b. Cover from view can be obtained by the skilful use of trees, bushes and crops. Permanent defensive positions require camouflage placed carefully so as to appear natural.

- c. In selecting a fire position for use at night, the danger of dead ground near the position and the importance of places where the enemy will be seen in silhouette are to be considered.

6. Confirm by Questions.

7. Trenches. Explain and demonstrate.

- a. To get the best firing position, use the right corner of the trench. Place both elbows on the elbow rest and the forearm against the cover, see Figure 2-40. Left handed firers use left corner.
- b. The soldier is to be afforded the maximum protection from the cover in the front of the trench.
- c. If the trench is shallow, kneeling, squatting or standing with the feet apart will lower the position.
- d. If the trench is deep, stand on an ammunition box or sandbag.

8. Bushes, Trees and Buildings. See Figures 2-41 and 2-42.

Emphasize that cover from view does not necessarily mean cover from fire.

Explain and demonstrate.

- a. Fire around the right side of cover unless better concealment is being afforded by shadow on the other side.
- b. If the cover is narrow, get directly behind it and keep the legs together.

9. Scrub. Emphasize that scrub does not provide cover from fire.

Explain and demonstrate.

- a. When firing from scrub, the squatting or kneeling position may be used for short periods.
 - b. If the position is to be occupied for some time, use the sitting position which is the least tiring.
 - c. Firing from the lower branches of large trees sometimes provides a better view of the arc of fire.
10. Low Banks and Folds in the Ground. Explain and demonstrate.
- a. To obtain maximum protection in the position, muzzle clearance is kept as close to the top of the bank or the crest of the fold as possible.
 - b. The shape of the ground may necessitate lying at a greater angle to the line of fire than is normal.
11. Walls and Houses. See Figure 2-43. Explain and demonstrate.
- a. In street fighting, walls and houses provide useful cover for fire positions.
 - b. When possible remove a few bricks near ground level and fire through a wall, rather than over the top.
 - c. A wall, one brick thick, does not give much protection from fire but it is useful for concealment.
12. Confirm by Practice.
13. Conclusion
- a. Take questions from the class on the entire lesson.
 - b. Confirm by questions and practice.
 - c. Conduct safety precautions.
 - d. Pack kit.
 - e. Summary. To include the following:
 - (1) rest the forearm whenever possible;

- (2) apply the marksmanship principles regardless of the firing position or the type of cover being used, remembering that accuracy is affected by the way cover is used; and
- (3) a forecast of the next lesson in this subject.

LESSON 13 - BAYONET FIGHTING

235. GRAPHICS

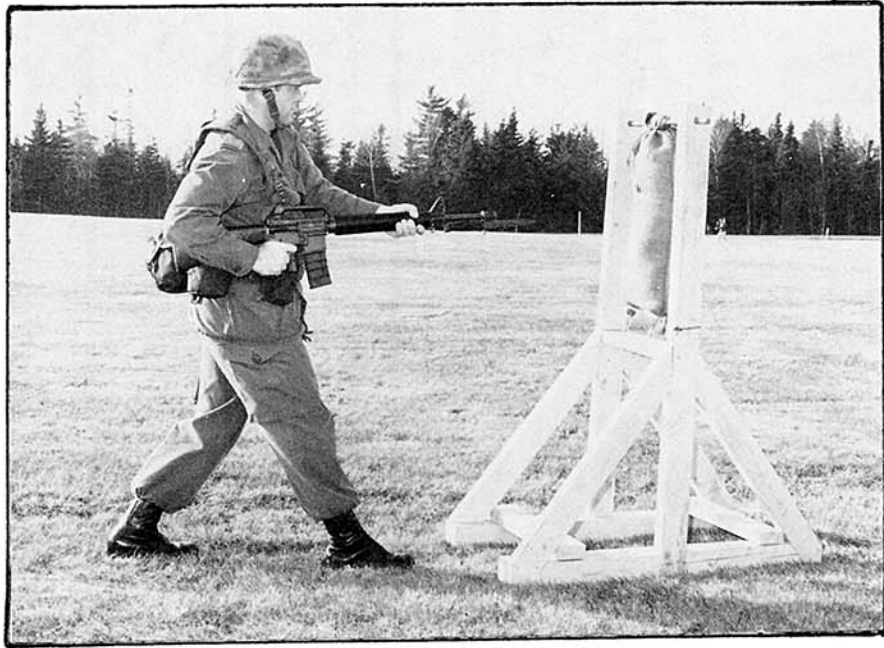

Figure 2-44 On Guard

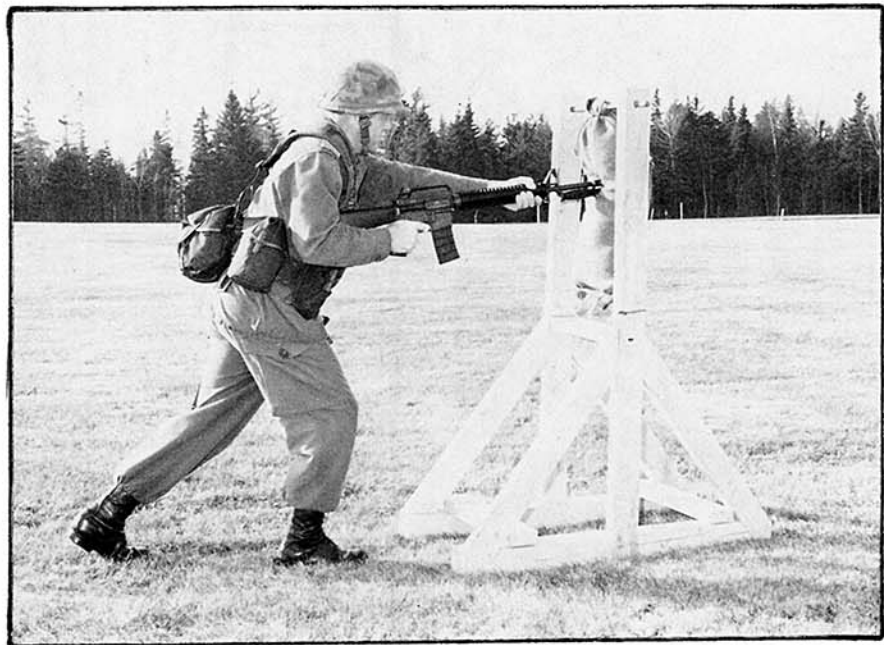

Figure 2-45 Thrust



Figure 2-46 Enemy On The Ground - On Guard



Figure 2-47 Enemy On The Ground - Thrust



Figure 2-48 Parry



Figure 2-49 Butt Stroke

236. INSTRUCTOR'S NOTES

1. Aim. To teach how to attack and kill the enemy with the bayonet and methods of self-defence.
2. Timings. Two 40-minute periods.
3. Method. Advanced instructional periods to be taken on a bayonet training area, the periods are not to be taken consecutively.
4. Stores
 - a. Rifles with slings fitted 1 per soldier
 - b. Bayonets and scabbards 1 per soldier
 - c. Dummy enemy, standing 1 per three soldiers
 - d. Dummy enemy, lying 1 per three soldiers
 - e. Gallows 1 per three soldiers
 - f. Training sticks 1 per standing dummy
 - g. First aid kit 1 complete
5. Preparation
 - a. Reconnoitre the training area and decide on locations for dummy enemy.
 - b. Put out dummies, ensuring that lateral spacing between dummies is not less than three metres.
 - c. Jackets and headdress should be removed except in inclement weather.
 - d. Left-handed soldiers are to be in the right flank of the squad as they face the dummies.
 - e. Rifles are to be prepared to fire during the period.
6. Miscellaneous
 - a. Avoid teaching bayonet fighting as a drill. It is a quick, instinctive skill with each situation likely to demand variations in technique.

- b. The instructor must instil a spirit of vigour and determination into the soldiers. Make them do everything at the double, except where it is otherwise stated. The keynote is speed and vigour; if a soldier is quick and vigorous, do not penalize him for small technical faults.
- c. Encourage the soldiers to develop a style to suit their size and build.
- d. Before beginning practice, emphasize that on the command **STOP**, the soldiers are to stop immediately and freeze. This is to enable dangerous practices to be corrected and to prevent accidents.
- e. During any practice when soldiers are required to pass one another, they are to do so with the rifle at the **HIGH PORT** and to the left of each other, ie, right shoulder to right shoulder.
- f. The instructor's position at all times is to be such as to allow him to observe from a flank, the individual actions of the entire squad.
- g. Organize the soldiers in details, ten metres from the dummies. Words of command are **FRONT RANK, ON GUARD, ONE THRUST AT THE WALK (DOUBLE) ... THRUST.**
- h. Soldiers are to pass the dummy to the left.
- j. To practise killing a number of enemy, arrange the dummies in pairs, one dummy of each pair one metre behind and to the left of the other. Increase this distance to five metres for further practice. To prevent accidents, make certain that all rear dummies are offset in the same direction from the forward dummies.

237. CONDUCT OF THE LESSON

1. Safety Precautions. Normal. Fit and test bayonets for security.
2. Review. High port position.
3. Introduction. Explain that the threat, or use of the bayonet in a Close Quarter Battle situation, can have a considerable effect on the enemy's morale.
4. ON GUARD Position. See Figure 2-44. Explain and demonstrate.
 - a. Adopt ON GUARD position when the enemy position is approached in an assault, or when about to attack the enemy with the bayonet.
 - b. To adopt the ON GUARD position, grip the rifle firmly by the pistol grip and handguard, point the bayonet at the enemy and adopt a natural fighting attitude.
5. Confirm by Practice.
6. To Kill a Standing Enemy. Explain and demonstrate.
 - a. Adopt the ON GUARD position.
 - b. Thrust at the enemy when approximately two metres away.

Grip the rifle firmly, bring the rear foot forward or jump with both feet and stick the bayonet into the enemy with the whole weight of the body behind the rifle, see Figure 2-45.
 - c. To withdraw the bayonet, pull the rifle straight back until the bayonet is out, punch forward ON GUARD and advance.
7. Confirm by Practice.

8. To Kill an Enemy on the Ground. See Figures 2-46 and 2-47.

Explain and demonstrate.

- a. Adopt the ON GUARD position.
- b. Thrust as taught but keep both feet clear of the enemy.
- c. To withdraw the bayonet, it may be necessary to stamp one foot on the enemy near to the bayonet; adopt the ON GUARD position and advance.

9. Confirm by Practice.

10. To Kill a Number of Enemy. Explain and demonstrate.

- a. Adopt the ON GUARD position.
- b. Thrust at the nearest enemy; if the next one is out of range, punch forward ON GUARD, advance on him and thrust again.
- c. If the enemy is so close as to be unable to come ON GUARD, withdraw from the first thrust and from that position thrust, withdraw and advance. Deal similarly with other enemy.

11. Confirm by Practice.

12. Firing During Bayonet Assault. Explain that when assaulting an enemy position with the bayonet, the order may be given to fire during the last few metres when the rifle is held in the ON GUARD position. The purpose of such firing is to keep the enemy's heads down after the supporting fire has ceased, or has been switched. There is a tendency to shoot high so try to keep the muzzle slightly down when firing. Keep firing on the move until gaining the enemy position, or until ordered to stop.

13. Confirm by Practice.

14. **Defensive Action.** Explain and demonstrate.
 - a. When the enemy attacks with the bayonet, be aggressive, make an opening and kill the enemy.
 - b. If the enemy's bayonet is directed to the right of the rifle, parry the thrust by straightening the left arm vigorously, thus fending off his bayonet; point the bayonet at the enemy, thrust, withdraw, come ON GUARD and advance.
 - c. If the enemy attacks to the left, beat off the thrust to the left, jump round, swing the rifle round and hit the enemy on the head with the butt or pistol grip, knocking the enemy to the ground, then thrust the bayonet into the enemy, withdraw, come ON GUARD and advance, see Figures 2-48 and 2-49.
 - d. If, when attacking, the rifle is parried off to the right, the enemy will instantly follow up with a butt stroke. To avoid this, act quickly and violently first to avoid the butt stroke, and then to kill the enemy. How it is done depends on the opening the enemy gives. These actions cannot be practised.
15. **Confirm by Practice.**
16. **Conclusion**
 - a. Take questions from the class on the entire lesson.
 - b. Confirm by questions and practice.
 - c. Conduct safety precautions.
 - d. Pack kit.
 - e. Summary. To include the following:
 - (1) the need for speed and vigour when bayonet fighting;
and
 - (2) a forecast of the next lesson in this subject.

LESSON 14 - ANTI-AIRCRAFT DRILLS

238. GRAPHICS



Figure 2-50 Aircraft Action - Kneeling Position

239. INSTRUCTOR'S NOTES

1. Aim. To teach how to fire at aircraft.
2. Timings. One 40-minute period.
3. Method. A basic instructional period.
4. Stores
 - a. Rifles 1 per soldier
 - b. Aircraft diagrams:
 - (1) Crossing left to right 2 for instructor
 - (2) Crossing right to left 2 for instructor
 - (3) Head on 4 for instructor

5. **Preparation.** Fix targets on each of two opposite walls as follows: "Crosser", "Head On", "Head On" and "Crosser" at approximately one and a half metre intervals.

6. **Miscellaneous.** Start the lesson with the class in the centre of the room facing one of the sets of aircraft diagrams.

240. **CONDUCT OF THE LESSON**

1. **Safety Precautions.** Normal then order LOAD.

2. **Review.** Nil.

3. **Introduction.** Explain that the weapon is capable of damaging low flying aircraft. It is essential that each soldier knows how to engage enemy aircraft which fly directly toward him or across his front.

4. **Rules for Engaging Aircraft.** Explain.

- a. Owing to the high speed of aircraft, it is essential that fire is delivered quickly and with reasonable accuracy. Rifle fire collectively controlled is an effective deterrent against low flying aircraft.
- b. Aircraft over 610 metres (2000 feet) are not to be engaged. As a rough guide to estimating height, not much more than a silhouette is visible above 610 metres (2000 feet) whereas details are visible below 610 metres (2000 feet).
- c. Enemy aircraft are to be engaged only when an order to do so has been given and then subject to the following conditions:
 - (1) The aircraft is recognizable by its markings as an enemy aircraft.
 - (2) The aircraft is seen to attack a ground target.
 - (3) The aircraft, excluding light aircraft and helicopters, dives onto an object. Light aircraft and helicopters

are excluded because friendly ones are liable to fly anywhere without notice and may dive suddenly in order to take evasive action. Sighting of suspected enemy light aircraft or helicopters is to be reported immediately.

5. Confirm by Questions.

6. Actions on the Command AIRCRAFT ACTION. Explain and demonstrate.

- a. Adopt the HIGH PORT position, or if applicable, hold the rifle as for the HIGH PORT and adopt the kneeling position, sitting back on the right heel. Keep the upper part of the left arm parallel, or higher, to the ground. This ensures that low firing, which could endanger friendly forces, cannot occur, see Figure 2-50.
- b. Set the sights for maximum range and move the selector lever to 'R'.

7. Confirm by Practice.

8. Firing at HEAD ON Aircraft, Action on STOP and CEASE FIRING.

Explain and demonstrate.

- a. On the command AIRCRAFT FRONT, raise the rifle quickly into the shoulder, put the finger on the trigger and aim at the centre of the aircraft. On the command RAPID FIRE, fire as previously taught. If the safety angle cannot be maintained stop firing, and adopt the high port position.
- b. On the command STOP, stop firing but do NOT put the selector lever to 'S'.

- c. On the command **CEASE FIRING**, return to **HIGH PORT** position and **MAKE SAFE**.
9. **Confirm by Practice.** Order **AIRCRAFT ACTION**.
10. **Crossing Aircraft.** Explain and demonstrate.
 - a. On the command **AIRCRAFT LEFT/RIGHT - RAPID FIRE**, aim using the sights as previously taught or by sense of direction if the aircraft is very close or moving very fast.
 - b. Swing the rifle quickly in the same direction as the aircraft movement, pass through and beyond the aircraft until a lead of at least 216 mils (12°) has been established. The spread of four fingers at arms length is approximately 200 mils. Maintaining the swing and fire at the rapid rate.
 - c. Actions on the commands **STOP**, **CEASE FIRING** and for maintaining the safety angle are as previously taught.
11. **Confirm by Practice.** Order **STOP** during the final practice.
12. **Turning.** Explain and demonstrate.
 - a. After the command **STOP**, if the command **AIRCRAFT RIGHT/LEFT/ABOUT** is given, turn quickly, pivoting on the right leg, in the direction named and aim as taught. If turning about, turn right about.
 - b. Actions on the command **RAPID FIRE** are as previously taught.
13. **Confirm by Practice.**
14. **Conclusion**
 - a. Take questions from the class on the entire lesson.
 - b. Confirm by questions and practice.
 - c. Conduct safety precautions.

d. Pack kit.

e. Summary. To include the following:

- (1) the importance of keeping the upper left arm parallel to the ground;
- (2) the importance of speed in carrying out the actions;
and
- (3) a forecast of the next lesson in this subject.

(241 to 299 Inclusive: Not Allocated)

CHAPTER 3

PRACTICE PERIODS

PRACTICE 1 - LESSONS 1, 2 AND 3

301. INSTRUCTOR'S NOTES

1. Aim. To practise:

- a. stripping, assembling, knowledge of parts and magazine filling, and
- b. load, prepare to fire, make safe, unload and safe handling.

2. Timing. Three 40-minute periods.

3. Method. An indoor practice period.

4. Stores

- a. Rifles 1 per soldier
- b. Dummy rounds 30 per soldier
- c. Cleaning kits 1 per soldier
- d. Stop watch 1 per soldier
- e. Chalkboard 1 per soldier
- f. Scoresheet 1 per soldier

5. Preparation. Prepare a chalkboard for the final practice.

Name	Magazine Filling		Stripping/Assembling		Loading		Unloading		Total Points
	Time	Points	No. of Faults	Points	Time/Faults	Points	Time/Faults	Points	

Figure 3-1 Practice 1 Scoresheet

6. **Miscellaneous**

- a. To control the timed tests during final practice, the set timings, when reached require to be called out, ie, Test 1 - Magazine Filling ' ...30..38..40..42'.
- b. Reteaching is only to be done when considered absolutely necessary.
- c. To practise the soldier in handling his weapon at night it is recommended that magazine filling, loading, ready and safe handling be conducted indoors using artificial night lighting.

302. **CONDUCT OF LESSON**

1. **Safety Precautions.** Normal.
2. **Review.** Nil.
3. **Introduction.** Explain that in battle the soldier's life and those of his comrades, depends to a great extent on his ability to carry out the basic skills of loading, unloading, making safe, etc, as instinctive actions. This ability is only acquired after a great deal of practice.
4. **Stripping and Assembling.** Explain that in the training tests the soldier is to strip his rifle as for cleaning and re-assemble it. The soldier fails if he makes any mistakes which affect safety.
5. **Practise the class in stripping and assembling different parts of their rifles.** When they can strip each part accurately practice them in complete stripping and assembling.
6. **Names of Parts.** With rifles stripped, question the class in the recognition of parts.

7. Magazine Filling
 - a. Explain. The soldier is to be tested in his ability to fill a magazine quickly and correctly. Full marks are awarded to the soldier who is able to fill a magazine with 30 rounds in 40 seconds or less.
 - b. Practise the class.
8. Load, Range, Make Safe and Unload
 - a. Explain. Skilled standard is awarded in the training tests to the soldier who loads his rifle correctly in ten seconds or less and unloads correctly in 12 seconds or less. Two seconds are added for each mistake, unless it involves safety, in which case the soldier fails.
 - b. Practise the class; use the commands LOAD, RANGE... 200, MAKE SAFE AND UNLOAD.
 - c. Question the class on the meaning of the commands.
9. Safe Handling
 - a. Question the class on safe handling rules.
 - b. Practise the class in safe handling drills involving rifles with magazines fitted/not fitted. Use simple situations, eg, leaving a rifle under guard, collecting a rifle from stores, etc, as practical illustrations.
10. Final Practice
 - a. Conduct the practice as a competition.
 - b. Divide the class into two teams, each soldier fault-checking his opposing team member.

- c. Practise each team in turn in stripping and assembling, magazine filling, loading, ready, making safe and unloading.
- d. Where applicable, call out the set timings as per training test standards as they are reached.
- e. Record individual and team scores on the chalkboard.

11. Conclusion

- a. Take questions from the class on the entire lesson.
- b. Conduct safety precautions.
- c. Pack kit.
- d. Summary. To include the following:
 - (1) the overall standard achieved and any weak points; and
 - (2) a forecast of the next lesson in this subject.

PRACTICE 2 - LESSONS 4, 5 AND 6

303. INSTRUCTOR'S NOTES

1. Aim. To practise:

- a. aiming, the prone position and hold, testing and adjusting the position, firing the shot and the follow through;
- b. correcting errors by altering the sight or the point of aim, and the allowances to make for different types of wind; and
- c. deliberate, rapid and snaphooting drills and the alert position.

2. Timings. Two 40-minute periods.

3. Method. An indoor or outdoor practice period.

4. Stores

- a. Rifles 1 per soldier
- b. Eye discs 1 per soldier
- c. Sight picture aim diagrams 1 per soldier
- d. Representative targets 1 per soldier
- e. Figure 11 Target on a
1.220 metre (four foot screen) 1
- f. Aiming rest 1 (minimum requirement)
- g. Stop watch 1
- h. Ruler 1
- j. Chalkboard 1
- k. Scoresheet 1
- m. Map pins 5

5. Preparation

- a. Position targets.
- b. Pin a sheet of paper to a vertical surface.
- c. Prepare a chalkboard for the final practice:

NAME	AIMING (HPS: 5)	HOLDING (HPS: 5)	TESTING AND ADJUSTING (HPS: 5)	AIMING OFF (HPS: 10)	FIRING (HPS: 10)	TOTAL

Figure 3-2 Practice 2 Scoresheet

d. Prepare a score sheet containing the following conditions and scoring:

- (1) Aiming. Three mm (1/8 inch) = 5 points. Five mm (3/16 inch) = 4 points. Six mm (¼ inch) = 3 points. Eight mm (5/16 inch) = 2 points. Nine mm (3/8 inch) = 1 point.
- (2) Holding. Order DOWN ... LYING POSITION HOLD ... STAND UP. Deduct one point for each mistake. HPS: five.
- (3) Testing and Adjusting. Order DOWN ... READY ... ALIGN ON TO THE EYE DISC ... REST ... EYES SHUT - RE-ALIGN. Repeat five times. Deduct one point for each incorrect alignment. HPS: 5.
- (4) Aiming off for Direction and Elevation. Explain, using a Figure 11 on a 1.220 metre (four foot) screen. The position of each shot to be indicated has been fired correctly using the correct aiming mark. Practise the class in showing, using a map pin, the amount of aim off required to bring the shot into the centre of the target. Give five examples and deduct one mark for each incorrect answer. HPS: 5.
- (5) Fire Orders. Order DOWN, RANGE 200 - FIVE ROUNDS - FIRE WATCH AND SHOOT ... STOP ... RAPID ... FIRE ... STOP.
Deduct one point for each mistake. HPS: 10.

6. **Miscellaneous**

- a. Prone Position and Hold. Practice in steady holding can be given if another member of the class balances a small coin on the barrel.
- b. Testing and Adjusting Position. Practise as follows:
 - (1) Soldiers using eye discs are to adopt a position which requires the firer to adjust his position.
 - (2) When the firer considers he is correctly aligned onto the eye disc, get him to rest his rifle, then, keeping his eyes shut, re-adopt his firing position. If his position is correct, then he should be correctly aligned when he opens his eyes and checks his aim.
- c. Aiming. Pin a sheet of paper to a vertical flat surface. Fix a rifle in a rest 3 metres (10 feet) away. Hold an eye disc against the piece of paper and let the soldier give directions for the movement of the eye disc until he considers the aim is correct. If this is repeated five times and the rifle has not been moved, a group of pin holes will have been formed. The size of this group indicates how well the principle of aiming has been mastered.
- d. Firing. Snapshooting exposures are to allow for two rounds in eight seconds. Rapid fire is to be five rounds in 30 seconds.
- e. Critics. When possible during the final competition, use the teams not being tested to act as critics.

304. **CONDUCT OF LESSON**

1. **Safety Precautions.** Normal.

2. Review. Nil.
3. Introduction. Explain that in battle the soldier is required to shoot accurately and quickly. To attain this ability the basic marksmanship principles must be practiced until they become instinctive action. It is equally important that he understands how to make alterations quickly to his POA and thus ensure a hit on the enemy. His ability to do this depends on a great deal of practise.
4. Aiming. Practise the class in the correct aim picture by using:
 - a. eye discs;
 - b. rifles in rifle rests at representative targets from a distance of ten metres; and
 - c. aim assessment sheet/eye disc, see Article 303-6,c.
5. Prone Position and Hold. Practise the class in the following:
 - a. correct drill for adopting the prone position;
 - b. correct prone hold position; and
 - c. correct actions on getting up from the prone position.
6. Eye Discs. Question the class on the correct use of the eye disc.
7. Testing and Adjusting Position. Practise the class in the following:
 - a. determine faults in the firer's position;
 - b. the methods of adjusting to eliminate faults in the firer's position; and
 - c. confirming that the position is correctly aligned.
8. Firing the Shot, Following Through and Declarations:
 - a. Practise the class in the following:
 - (1) combining the trigger slack application, the breathing pause and the aim; and

- (2) the trigger operation and the follow through.
- b. Question the class on how to determine faults in the firing drill from the movement of the foresight or point after the shot is fired.
9. **Target Sizes and Group Sizes.** Question the class on the dimensions of the Figure 11 and Figure 12 targets, the definition of a group, the meaning of MPI and firer's grouping capacity.
10. **Elevation and Wind.** Practise the class in solving problems involving alteration of sights and point of aim.
11. **Types of Fire.** Question the class on the uses of deliberate, snapshooting and rapid types of fire.
12. **Deliberate, Snapshooting and Rapid Fire.** Practise the class in the actions carried out on the commands **FIRE, WATCH AND SHOOT, RAPID... FIRE, STOP** and **GO ON**.
13. **Final Practice.**
- Conduct the practice as a competition for three teams.
 - Explain the conditions before each practice.
 - Practice each team in turn, in aiming, holding, testing and adjusting positions, deliberate, snapshooting and rapid fire.
 - Record each score on a chalkboard.
14. **Conclusion**
- Take questions from the class on the entire lesson.
 - Safety precautions.
 - Pack kit.
 - Summary. To include the following:
 - the overall standard achieved and weak points; and
 - a forecast of the next lesson in this subject.

PRACTICE 3 - LESSON 7

305. INSTRUCTOR'S NOTES

1. Aim. To practise firing from the kneeling, sitting, squatting and standing positions.
2. Timings. One 40 minute period.
3. Method. An outdoor practice period.
4. Stores
 - a. Rifles 1 per soldier
 - b. Eye discs 1 per soldier
 - c. Figure targets on small stakes 6 (minimum requirement)
 - d. Stop watch 1 per soldier
 - e. Chalkboard 1 per soldier
5. Preparation. Reconnoitre the training area and select:
 - a. A fairly flat area of ground approximately 12 by 50 metres to practise kneeling and standing positions. Position three targets at intervals at one end of the area.
 - b. A bank or forward slope as close as possible to the flat area to practise the sitting position. Position three targets 20 metres forward of it.
 - c. Check that the stopwatch functions correctly.
 - d. Prepare a chalkboard for the final practice:

Name	Match 1 (HPS: 10)	Match 2 (HPS: 10)	Total (HPS: 20)

Figure 3-3 Practice 3 Scoresheet

6. Miscellaneous

- a. Supervision should be related to the firer adopting a correct position and firing during the breathing pause.
- b. Adopting the Correct Positions. Use the flat area of ground to practise the kneeling, squatting and standing position and the bank for the sitting position. Use commands ADOPT THE KNEELING/ STANDING POSITION, ETC, ...RANGE 200 ...AIM. Allow the class up to six seconds to complete the aim each time but do not have them firing at this stage. Give sufficient practice in the kneeling and standing positions to allow each soldier to be checked individually. Move to the bank and repeat for the sitting positions.
- c. Deliberate Firing from the Positions. Divide the class into assistants and firers. Use the command KNEELING POSITION... RANGE 200...FIRE. Check each soldier's actions then order STOP. Order a new position and GO ON. Continue until each soldier has been checked in the kneeling, squatting and standing positions. Use an eye disc as appropriate. Move to the bank and repeat for the sitting positions.
- d. Snapshooting from the Positions. Divide the class into two groups; one group firing and the other using eye discs. Organize exposures of six seconds for the eye disc operators and practise the kneeling and sitting positions. Order KNEELING, ETC...RANGE 200...WATCH AND SHOOT. Check each firer's aim. Change teams and repeat. Continue until each soldier's aim has been checked.

- e. Final Practice. Two teams standing at ease 20 metres apart and facing each other paired off as opponents. Order RANGE 200 - TRAIL POSITION...KNEELING. On the command KNEELING, the teams are to run forward five metres, adopt the kneeling position and fire one shot. Award two marks to the soldier in each pair who is first to adopt the correct position and fire. Practise this five times in each match using different positions. The third team is to act as critics.
- HPS: 10 per soldier per match.

306. CONDUCT OF THE LESSON

1. Safety Precautions. Normal.
2. Review. Nil.
3. Introduction. Explain that in battle, the soldier is required to handle and fire his rifle from all the known firing positions. In order to kill the enemy, the position adopted needs to be stable enough to allow the soldier to apply the marksmanship principles. A great deal of practice is necessary before the soldier is able to adopt the correct position instinctively.
4. Suggested Practice
 - a. Question the class as to when the various fire positions are used.
 - b. Practise the class in adopting the correct positions for kneeling, standing for a quick shot, standing for a deliberate shot, squatting and sitting.
 - c. Practise the class in deliberate firing from the positions at static targets.
 - d. Practise the class in snaphooting from the positions.

5. **Final Practice**

- a. Conduct the practice as a competition.
- b. Divide the class into three teams; two competing, one checking.
- c. Practise the teams against each other in firing from the positions.
- d. Record individual and team scores on the chalkboard.

6. **Conclusion**

- a. Take questions from the class on the entire lesson.
- b. Conduct safety precautions.
- c. Pack kit.
- d. Summary. To include the following:
 - (1) the overall standard achieved and weak points; and
 - (2) a forecast of the next lesson in this subject.

PRACTICE 4 - LESSONS 8 AND 9

307. INSTRUCTOR'S NOTES

1. Aim

- a. To confirm knowledge of the rifle mechanism, the Immediate Action (IA) and stoppages.
- b. To practise correcting errors by altering the sight or the point of aim, and the allowances to make for different types of wind.

2. Timings. Two 40 minute periods.

3. Method. An indoor or outdoor practice period.

4. Stores

- | | |
|--|---------------|
| a. Rifles | 1 per soldier |
| b. Dummy rounds | 1 per soldier |
| c. Cleaning kits | 1 per soldier |
| d. Ground sheet | 1 per soldier |
| e. Representative targets | 1 per soldier |
| f. Figure 11 Target on a 1.2 m
(four foot) screen | 1 |
| g. Chalkboard | 1 per soldier |
| h. Score sheet | 1 per soldier |

5. Preparation.

- a. Prepare a chalkboard for the final practice.

Name	IA and Gas (HPS: 10)	Further Action (HPS: 5)	Aiming Off (HPS: 5)	Total (HPS: 15)

Figure 3-4 Practice 4 Scoresheet

- b. Prepare a score sheet containing the following conditions and scoring:
- (1) Immediate Action (IA) and Gas Stoppage. Order LOAD-DOWN-RANGE 100-RAPID FIRE. As soon as the trigger is pressed, order RIFLE STOPS. When, in carrying out the IA, the firer looks at the position of the bolt carrier, order BOLT CARRIER PARTIALLY FORWARD - EMPTY CASING IN THE RECEIVER. As soon as the trigger is pressed, order RIFLE STOPS. When in carrying out the IA, the firer looks at the position of the bolt carrier again, order BOLT CARRIER FORWARD. As soon as the rifle is cocked order A ROUND HAS BEEN EJECTED. Deduct one mark for each error of drill unless it affects safety, in which case award no marks. HPS: 10.
 - (2) Further Action. Order LOAD-DOWN-RANGE 150 - RAPID FIRE. As soon as the trigger is pressed, order RIFLE WON'T FIRE. When, in carrying out the IA, the firer looks at the position of the bolt carrier, order BOLT CARRIER FORWARD. As soon as the rifle is cocked, order ROUND NOT EJECTED. As soon as the firer strips the rifle order BROKEN EXTRACTOR. Deduct one mark for each error of drill unless it affects safety, in which case deduct five marks. HPS: 5.
 - (3) Aiming Off For Direction and Elevation. Explain, using a Figure 11 on a 1.2 metre screen. The position of each shot to be indicated has been fired correctly using the correct aiming mark. Practise the class in

showing, using a map pin, the amount of aim off required to bring the shot into the centre of the target. Give five examples and deduct one mark for each incorrect answer. HPS:5.

6. **Miscellaneous**

- a. IA and Stoppages. Use representative targets to aim at. Ensure that the correct firing drills are carried out after the soldier completes the stoppage drill.
- b. Elevation and Wind Allowance. Allow soldiers to indicate their answer using map pins on a Figure 11 target superimposed on the 1.2 metre screen. Make use of the positions 150 mm, 300 mm and 450 mm above and below the POA in set examples.
- c. Final Practice. During the final practice, divide the class into two groups, use one as critics and the other as firers.

308. **CONDUCT OF THE LESSON**

1. **Safety Precautions**. Normal.
2. **Review**. Nil.
3. **Introduction**. Explain that it is important that the soldier is able to recognize and remedy quickly any stoppages that may occur with his rifle. It is equally important that he understands how to make alterations quickly to his POA and thus ensure a hit on the enemy. Practice is essential.
4. **Basic Mechanism**. Question the class on the rifle mechanism. Make the soldiers use their rifles to illustrate their answers.
5. **Immediate Action (IA)**. See Article 307-6a.

6. **Further Action.** See Article 307-5b(2). Practise the class in the correct drill for a broken part.
7. **Target Sizes and Group Sizes.** Question the class on the dimensions of the Figure 11 and Figure 12 Targets, the definition of a group, the meaning of MPI and the firer's grouping capacity.
8. **Elevation and Wind Allowance.** Practise the class in solving problems involving alteration of the POA for elevation and wind strengths.
9. **Final Practice.** See Instructor's Notes.
 - a. Conduct the practice as a competition.
 - b. Explain the conditions for each practice.
 - c. Record team scores on a chalkboard.
10. **Conclusion**
 - a. Take questions from the class on the entire lesson.
 - b. Conduct safety precautions.
 - c. Pack kit.
 - d. Summary. To include the following:
 - (1) the overall standards achieved and weak points; and
 - (2) a forecast of the next lesson in this subject.

PRACTICE 5 - LESSONS 10 AND 12

309. INSTRUCTOR'S NOTES

1. Aim. To practise:
 - a. methods of carrying a rifle and firing at close quarters; and
 - b. how to handle and fire a rifle from behind cover.
2. Timings. One 40 minute period.
3. Method. An outdoor practice period.
4. Stores
 - a. Rifles 1 per soldier
 - b. Figure targets on small stakes 4 (minimum requirement)
5. Preparation
 - a. Reconnoitre the training area and select the following:
 - (1) a flat area approximately 30 - 50 metres in length; and
 - (2) an area affording use of different types of cover, ie, bushes, walls, trees, rubble, low banks, etc.
 - b. Put out targets as in Figure 3-5 on the fairly flat area.
 - c. Prepare a chalkboard for the final practice.

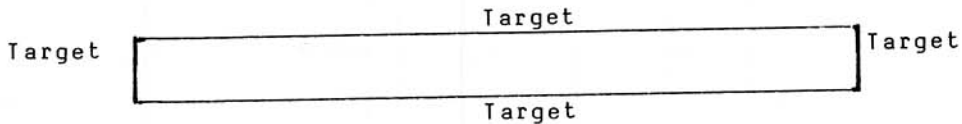

Figure 3-5 Target Layout

Name	Close quarter shooting (HPS: 5)	Use of Cover (HPS: 5)	Total (HPS: 10)

Figure 3-6 Practice 5 Score-sheet

- d. Prepare a score sheet containing the following:
- (1) Close Quarter Shooting. Two teams, rifles ready to fire at the HIGH/LOW or ALERT position, facing each other, 20 metres apart, and paired off as opponents. Order ADVANCE ... STANDING/KNEELING/SQUATTING/SITTING POSITION ... FIRE ... RANGE ... ADVANCE, etc. Award one mark to the soldier in each pair who is first to adopt the correct position and fire. Practise this five times. The third team to act as critics. HPS: 5.
 - (2) Use of Cover. Indicate to each team an area of ground to be used for fire positions and the arc of fire to be covered. Allow the teams to occupy their fire positions. Leave two teams in their positions and call out the third team to criticize the fire positions of one team only. When the critique is completed change teams until all are exercised. Deduct one mark for each error in the fire position. HPS: 5.

6. Miscellaneous

- a. Methods of Carriage and Close Quarter Shooting. For stationary practice, position the class, rifles ready, at one end of a fairly flat piece of ground. Order HIGH/LOW PORT or ALERT, etc, then HIGH/LOW PORT or ALERT... KNEELING/STANDING/SITTING POSITION ... ENEMY FRONT/RIGHT/LEFT. Use the same commands preceded by RANGE ... ADVANCE for other practice.

- b. Handling and Firing Behind Cover. Indicate an area of cover to be used for fire positions and an arc of fire to be covered. Send half of the class at a time to take up fire positions and use the other half as critics.

310. CONDUCT OF THE LESSON

1. Safety Precautions. Normal.
2. Review. Nil.
3. Introduction. Explain that in battle the soldier is required to handle and fire his rifle from all the known firing positions, both in the open at close ranges and also from behind cover.
4. Methods of Carriage and Close Quarter Shooting:
 - a. Question the class as to when the high port, low port and standing alert positions are used.
 - b. Practise the class in close quarter shooting from the high port, low port and standing alert positions, stationary and during an advance.
5. Handling and Firing Behind Cover:
 - a. Question the class on the qualities of a good fire position.
 - b. Practise the class in taking up fire positions to cover an arc of fire and using any available cover.
6. Final Practice.
 - a. Conduct the practice as a competition for three teams.
 - b. Practise each team in close quarter shooting and the use of cover.
 - c. Record team scores on a chalkboard.

7. **Conclusion.**
 - a. Take questions from the class on the entire lesson.
 - b. Conduct safety precautions.
 - c. Pack kit.
 - d. Summary. To include the following:
 - (1) the overall standard achieved and weak points; and
 - (2) a forecast of the next lesson in this subject.

PRACTICE 6 - LESSON 13

311. INSTRUCTOR'S NOTES

1. Aim. To practise bayonet fighting.
2. Timings. Two 40 minute periods (not consecutive).
3. Method. An outdoor practice period.
4. Stores
 - a. Rifles 1 per soldier
 - b. Standing dummy enemy 6 (minimum requirement)
 - c. Lying dummy enemy 3 (minimum requirement)
 - d. Training sticks 6 (minimum requirement)
 - e. First aid kit 1 complete
 - f. Chalkboard 1
 - g. Scoresheet 1
5. Preparation
 - a. Reconnoitre the area and decide on locations for dummy enemy.
 - b. Put out dummies, ensuring that lateral spacing between dummies is not less than 3 metres (ten feet).
 - c. Prepare a chalkboard for the final practice:

Name	Total Faults (HPS: 10)

Figure 3-7 Practice 6 Score-sheet

- d. Prepare a score-sheet containing the following conditions and scoring. Order ON GUARD ... ONE THRUST AT ALL ENEMY, AT THE DOUBLE ... THRUST. Ten marks are allotted for a faultless round, deduct one mark for each error.

6. Miscellaneous

- a. Jackets and headdress should be removed except in inclement weather.
- b. Left-handed soldiers are to be on the right flank of the class as they face the dummies.
- c. Rifles are to be ready to fire during the period.
- d. If a soldier is quick and vigorous, do not penalize him for small technical faults.
- e. During any practice when soldiers are required to pass one another, they are to do so with the rifle at the HIGH PORT and to the left of each other, ie, right shoulder to right shoulder.
- f. The instructor's position, at all times, is to be such as to allow him to observe from a flank the individual actions of the entire class.
- g. Organize the soldiers in details, ten metres from the dummies. Words of command are FRONT RANK ... ON GUARD ... ONE THRUST AT THE DOUBLE ... THRUST.
- h. Soldiers are to pass the dummies to the left.
- j. To practise attacking and killing a number of enemy, arrange the standing dummies in pairs, one dummy of each pair one metre behind and to the left of the other. To prevent accidents, make certain that all the rear dummies are positioned on the same side. Practise silent, stealthy use of a bayonet by getting the soldiers to attack the dummies after crawling towards them.

k. Immediately prior to practising in defence, training sticks are to be put in position and lying dummies positioned to represent a fallen enemy after a butt stroke. Unless gallows are used do not allow the soldiers to strike the dummies or their supports with the butts otherwise rifles may be damaged.

m. Final Practice

(1) Lay out a semi-circular course of standing, single and double, and lying dummies. Attach training sticks to four of them.

(2) Detail one man as critic and one man to replace training sticks. Practise the first team completely before going on to the next, etc.

312. CONDUCT OF THE LESSON

1. Safety Precautions. Normal. Fit and test bayonets for security. Order LOAD ... RANGE 100.

2. Review. Nil.

3. Introduction. Explain that the soldier's success in fighting the attack and in defence, when using only the rifle and bayonet, is determined by the confidence he has in his own ability with the weapon. such confidence is only acquired through practice.

4. In the Attack. Practise the class in fighting one, two or more enemy. Use standing or lying enemy.

5. In Defence. Practise the class in the right parry, then in the left parry butt stroke and kill.

6. Final Practice

- a. Conduct the practice as a competition for three teams.
- b. Explain the conditions before the practice.
- c. Practice each team, in turn, attacking various enemy.
- d. Record team scores on a chalkboard.

7. Conclusion

- a. Take questions from the class on the entire lesson.
- b. Conduct safety precautions.
- c. Pack kit.
- d. Summary. To include the following:
 - (1) the overall standard achieved and weak points; and
 - (2) a forecast of the next lesson in this subject.

(313 to 399 Inclusive: Not Allocated)

CHAPTER 4

INFORMATION FOR INSTRUCTORS

SECTION 1 - COACHING TECHNIQUES

401. GENERAL

1. **Introduction.** This section details the individual aspects of coaching and the sequence in which these aspects are applied. The application of the various coaching techniques is determined by the standard of shooting involved.
2. Supervising Officers must always insist on professional coaching to ensure that soldiers are given every opportunity to improve their shooting capability. Bad coaching, in addition to causing poor results, destroys the individuals' desire to become an excellent shot.
3. From the basic lesson stage to the time the Personal Weapon Test is fired, expert coaching must be given every time soldiers fire a weapon, unless the conditions of the shoot exclude coaching. A pool system of coaches must be organized during all range periods.
4. Skill at Arms training is progressive and the type of firing and coaching at each stage is specifically designed to confirm satisfactory progress and the confidence of the firer. A soldier who knows that he is improving has the desire to make even more progress.

402. THE COACH

1. **Role.** The function of a coach is to give advice when required and to endeavour to spot and correct faults as early as possible. This is done in order to improve the soldier's shooting techniques and knowledge to such a degree that he acquires the ability and gains the confidence to use his weapon effectively in battle. To do this, the

coach must be alert and supremely patient, know the characteristics of the weapon and ammunition, and allow for the effect which the ability of the firer will have on these characteristics.

2. **Traits.** All coaches must be enthusiastic and set high standards not only for the soldiers they are coaching; but also, for themselves.

3. **Knowledge.** The coach must have a thorough knowledge and understanding of the following:

- a. all the basic lessons and the principles of marksmanship;
- b. the capabilities of the rifle and ammunition;
- c. the examination, testing and zeroing of the weapon to be fired;
- d. the theory of a group;
- e. the causes of poor shooting and how to rectify it; and
- f. the factors that affect the application of fire.

403. THEORY OF A GROUP

1. Once a coach knows the firer's grouping capacity at 100 metres, he can decide the smallest area that, in theory, should contain the firer's well aimed and fired shots at any other range. The size of the group varies in direct proportion to the range. That is, at 200 metres the group is twice the size that it would be at 100 metres, at 300 metres three times, and at 25 metres, one quarter the size.

2. In a deliberate practice the firer applies his group to the centre of the target and his grouping capacity determines his expected scoring area (ESA). For example, if the firer's grouping capacity is 200 mm (8 inches) at 100 metres, his ESA at 200 metres is a 400 mm (16 inch) circle with its centre in the middle of the target. If all his shots are good ones they should all be contained within a Figure 12 Target.

3. This theory is the basis of coaching, but the coach must apply it with common sense. For instance, a 100 mm (4 inch) grouper may not contain all his shots within a 300 mm (12 inch) circle at 300 metres, although that is his ESA. Wind, light and the sighting of the weapon can all affect his shooting. In addition the point of aim is always harder to see when firing at greater than at 100 metres. Also, he will not shoot as accurately when firing rapid or at a moving target.

404. POOR SHOOTING

1. The causes of poor shooting may be within or outside the firer's control. It is important that the coach first identify whether poor shooting is within or outside the firer's control.

a. Causes within the firer's control are:

- (1) Aiming. This can be caused by not seeing the correct aim picture every time, staying in the aim too long, or aiming incorrectly when adjusting for wind. Another major cause of incorrect aiming is the firer may vary the position of his head on the butt each time he aims giving a different sight alignment for each shot.
- (2) Trigger Operation. The firer may be snatching the trigger.
- (3) Body Movement. He may move his body as he fires.
- (4) Poor Breath Control. See Article 412.2.
- (5) Anxiety. The firer may be gun shy, over anxious to do well, or not determined enough.

b. Causes outside the firer's control are:

- (1) Meteorology. Poor light or severe weather adversely affect shooting skills.

- (2) Weapon. The weapon may be incorrectly zeroed, poorly maintained or the butt may be the wrong length.
- (3) Individual Soldier. The soldier may have poor eyesight, bad health or some other ailment affecting his shooting ability.
- (4) Improper Coaching or Range Organization.

405. COACHING DURING DRY PRACTICE

1. Dry practice coaching starts during the basic lessons when the instructor is checking and correcting faults. The type of practice conducted during lessons and practice periods should be designed to show up faults. It is important at this stage that the firer has the correct butt length.

2. During dry practice each principle of marksmanship should be examined for common faults. The following articles discuss each principle of marksmanship from the coaches viewpoint.

406. POSITION AND HOLDING

1. When the basic position has been adopted the coach must check through all the features from the tip of the barrel right down to the feet making adjustments as necessary to the various parts of the position.

2. When breathing has been restrained the rifle muzzle should be relatively steady; this can be checked by the instructor using an eye disc. Any unsteadiness may indicate that the firer is trying to exert too much control with the left hand or may be over tense in the area of the right shoulder. The assistance of a sandbag support may help to overcome this.

3. Practice in steady holding can be given if another member of the class balances a small coin on the barrel. When the firer can hold the coin on the barrel he is beginning to master the first principle, though this may take some time.

407. NATURAL ALIGNMENT

1. Using an eye disc, the instructor/coach should initially be in front of the firer in a position which will require the firer to adjust his position in order to aim at the eye disc. The coach should ensure that the firer adopts a consistent position, checking his ability to aim correctly and making adjustments by moving his body.

2. A suggested method of testing the firer's ability to adjust his position is to tell him to rest the rifle on the ground as for the loading position, close his eyes, bring the rifle into the shoulder and then open his eyes. He should be correctly aligned if the adjustment was done properly. If not, the coach must point out the error and start again with the adjustment of the position.

408. AIMING

1. It is difficult to assess correct alignment when using an eye disc and, therefore, an aiming rest is often a useful aid. This can be improvised from sandbags or from a box shaped to hold the rifle steady. Small representative targets should be positioned approximately three metres (10 feet) away from the rifle muzzle and the firer told to adjust the rifle and aiming rest until the aim is correct. Without moving the rifle the instructor/coach should check for correct alignment.

2. The degree of consistency in aiming can be assessed by using an eye disc and a sheet of paper or cardboard which is pinned to a vertical flat surface, eg, a wall or chalkboard. The rifle is placed in an aiming

rest approximately three metres (10 feet) away from the paper. The instructor/coach holds the eye disc against the sheet of paper and the soldier looks through the rifle sights, directing movement of the eye disc until he considers the aim to be correct. At this point the instructor/coach pushes a pin through the hole of the eye disc, moves the eye disc away and repeats the process five times. If the rifle has not been moved a group of five pin holes will now have been formed. The size of this group is a good assessment of how well the principle of sight alignment has been mastered. The firer should be able to produce five pin holes within a 3 mm (1/8 inch) circle. Once that standard is mastered further practice can be given at aiming off points selected by the coach or as problems set on wind allowances.

3. As a means of stimulating interest and competition between individuals, charts can be used to illustrate progress in mastering sight alignment.

409. SHOT RELEASE AND FOLLOW THROUGH

1. It is important to locate faults in shot release and this is best done during live firing. However, it is possible to dry practise using an assistant. The coach should watch for the following: a build up in tension just prior to shot release, incorrect trigger operation, movement of the rifle as the hammer strikes the firing pin, closing the sight eye, and incorrect follow through procedure on the trigger. If movement occurs, try to locate the source of movement. Use an assistant to hold the eye disc in order to give an indication of any muzzle movement at the moment of firing.

2. If the direction of muzzle movement is down and to the left (as seen by the assistant using the eye disc), the coach should watch the

right hand and finger for the next shot. Such movement is usually caused by the finger being snatched instead of developing the gradual increase in pressure which is required to release the shot. Another fault could be that the trigger finger moves forward again as the hammer is released, instead of being held to the rear.

3. If the muzzle movement is down and to the right, watch the right shoulder and left hand. A possible forward movement of shoulder muscles (in anticipation of recoil) could occur. This is more noticeable during live firing. A common fault with the left hand is often made by gripping the front end of the rifle to prevent upward movement during recoil.

4. If the muzzle movement is upwards and to the left look for a tendency to flinch. A fear of recoil and noise is usually the cause. Generally it will be seen that if the eye is closed at the moment of firing there is a tendency to move the head backwards and pull down with the right hand.

410. MAINTAINING INTEREST

1. During dry practice it is easy to lose the interest of firers unless competitive practice is promoted. As soldiers like to judge performance they should be encouraged to practise one another and criticize while the instructor/coach gives individual attention to others. It should be remembered that all firers are potential coaches, therefore, the earlier they learn the faults and how to spot them the better.

2. Dry practice is essential to eliminate common faults. Ammunition and range time are wasted if devoted to firers who have not first mastered the principles of marksmanship in dry practice.

411. COACHING DURING GROUPING PRACTICES

1. The coach must appreciate that bad weather conditions affect the performance of the individual.
2. Range Practice 1 recommends four groups of five. The coach should have binoculars or a telescope to assist him.
3. It must not be assumed that each firer makes all the faults every time. If in doubt, do not invent a fault even though a bad shot has been fired. Watch the next shots until it is possible to discover where the true fault lies.

412. PROCEDURE FOR COACHING BEFORE FIRING

1. Ensure that binoculars or telescope, coaches' notebooks and pencils are available.
2. Check that the firer understands what he has to do and the type of practice he is going to fire.
3. Check that he tests and adjusts his position correctly onto his own target. Adjust the sandbag to his forearm if necessary.
4. Lie down on the open side in a position from which his face and his right hand can be seen.

413. PROCEDURE FOR COACHING DURING FIRING

1. Watch the firer during each shot that is fired to see if any errors are made and note any observations in the coach's notebook. After each shot discuss with the firer his aim at the moment of firing and the action of the rifle during recoil. Ensure that the firer rests between shots with the selector lever on 'S'. Do not over-coach, let the firer concentrate on the principles he is trying to apply.

2. In addition to faults mentioned earlier, a common fault during early stages of shooting is to stay on aim too long. Insist that the shot is fired within six seconds of breathing being restrained. If it is not, tell the firer to rest. Holding the breath too long affects the firer's ability to concentrate. The image of the aim also imprints itself on the eye after a few seconds and takes time to clear before a true clear picture is seen again. This can be proved by looking at a bright light when, for a few seconds after looking away, the image can still be seen.

3. The firer who flinches must have this fact proved to him. A good way to do this is to give the firer a magazine prefilled with a mixture of dummy and live ammunition. When the firer fires the shot with a dummy cartridge the flinch will be very apparent provided that he does not know when the dummy cartridge is being fed into the chamber. Progressive practice and encouragement from his coach will soon cure this harmful instinctive reaction. It should be emphasised that the use of dummy cartridges and live rounds for this form of practice must be sanctioned by a Commanding Officer or equivalent Training Officer and be done in accordance with B-GL-304-003/TS-001 Operational Training, Volume 3, Ranges and Training Safety.

414. PROCEDURES FOR COACHING AFTER FIRING

1. When firing is completed examine the target with the firer. Compare the declaration made by the firer as each shot was fired with the order of arrival of shots on the target.
2. Check the size of the group, or, if more than one group has been fired, determine the average size of the groups. Check the position of the MPI to determine whether adjustments are needed to the rifle.

3. Check whether the pattern indicates any fault being made by the firer, or in the rifle. If in doubt, test the rifle by firing.

4. These procedures are not drills but are points that should be considered by the coach. After consideration, the coach should discuss essential points with the firer that will lead to improvement in his shooting. Make every effort to encourage the firer.

415. COACHING DURING APPLICATION OF FIRE

1. In practices, other than grouping, the aim of coaching is to ensure that the firer applies the centre of his group to the centre of the target. This means that he will obtain the maximum number of hits relative to his ability.

2. It must be appreciated that a single shot fired at a target will fall in a position related to where it would have fallen if it had been one of a series forming a group. If a shot falls within a firer's ESA, even if it misses the target, no adjustment is needed. If a shot falls outside the ESA, unless an error has been made, fire is not correctly applied and a correction may be required to the sights or point of aim.

3. Some of the common factors that can affect the application of fire are inefficient zero, wind, light, firing position, position support, attachments to the rifle, and wet/oily ammunition or chamber.

4. There are certain facts to be remembered if the coach wishes to alter a firer's point of aim or his sights:

- a. Do not alter on a bad shot - that is, a shot declared incorrect by the firer or observed to be incorrect by the coach.

- b. It is unwise to alter on a first shot unless it was declared correct by the firer and observed to miss well clear of the target.
- c. Do not alter if the shot is within his ESA.
- d. Alterations must be bold.

416. AIDS TO OBSERVATION

1. If a witness screen is not available it is difficult for the coach to pin point shots which have missed the target. The coach must try to obtain this information for himself, by positioning himself behind the firer at a point from which he can observe. Three aids he can make use of when observing are swirl, strike, and tracer.

2. **Swirl.** When the bullet passes through the air, air is displaced and a swirling effect is seen. Swirl is seen at the culminating point of the trajectory, which, is approximately two-thirds of the distance to the target and approximately 200 mm (eight inches) above the line of sight. It follows, therefore, that if a bullet is to hit the centre of a Figure 11 Target, swirl will appear at about face level. To see swirl accurately, the coach must look along and slightly above, the line of the barrel from a position directly behind the firer.

3. **Strike.** This can be seen on the stop butt of a gallery range or on the ground of an MTR. Strike can be misleading if the round ricochets from the target or the angle from the firing point to the target is not appreciated.

4. **Tracer.** If the firer misses with three consecutive shots on certain shoots, the use of tracer is permitted. Hits obtained with tracer ammunition are subtracted from the score.

417. COACHING DURING RAPID PRACTICES

1. Time is against the coach, therefore, he has to think quickly and is unable to discuss what is happening with the firer. To coach a rapid practice properly:

- a. binoculars are essential;
- b. the coach must be directly behind the firer; and
- c. coaching must be brief, to the point and as an order, eg,
GO SLIGHTLY RIGHT - STEADY.

418. GROUP COACH SYSTEM

1. It would be ideal to have one coach per firer but this is often not possible. To overcome this problem firers of different standards should be grouped with one coach, eg, a 100 mm (4 inch) grouper, a 200 mm (8 inch) grouper and a 300 mm (12 inch) grouper. The firers should be instructed to stop firing and raise their hands if they miss with a given number of consecutive shots, eg, one shot for the 100 mm (4 inch) grouper, or two shots for the 200 mm (8 inch) and 300 mm (12 inch) groupers.

2. This method permits the coach to concentrate more of his help on the poorer firers of the group.

419. SUMMARY

1. The techniques of coaching have no fixed rules, only guiding principles. A coach must understand that grouping is the foundation of shooting and that he must know where each round has gone. Good coaching eliminates many bad shots but bad coaching can achieve just the opposite. Coaching is never complete until the firer is able to shoot well by himself. Correct assessment of the firer's expected scoring area is the foundation of good coaching.

SECTION 2 - ZEROING

420. GENERAL

1. **Purpose.** To determine the true position of the Mean Point of Impact (MPI) a large number of shots, not less than 20, should be fired at the same aiming mark under the same conditions. If a smaller number of shots is fired the true position of the MPI cannot be determined accurately because of the random dispersal of the shots in the group. The act of zeroing is to superimpose the true position of the MPI on the correct zero position so that with the appropriate sight setting and use of wind allowance the group will form centrally at all other ranges.
2. It is essential that each soldier zero his own weapon. It is unusual for any two persons to have exactly the same zero with the same weapon.
3. **Distance.** Zeroing should be done on an open range at 100 m. If necessary it may be done at 25 m, however, the shorter the distance the greater the error which may be expected at longer ranges.
4. **Aperture.** The battle sight (large aperture) will be used to zero. On the C7 after zeroing if the small aperture is used to fire at ranges up to 300 m then the POA must be lowered to compensate for the difference between MPI's. The POA's and MPI's are coincidental at 300 m when using the small aperture.
5. **When to Zero**
 - a. On initial issue, or, when a weapon changes hands.
 - b. Before, and if possible, during combat.
 - c. Before firing the Personal Weapon Test.
 - d. After any repair which could affect the sighting system.
 - e. Whenever the accuracy of the weapon is in doubt.

6. How to Zero
 - a. Ensure the battle sight aperture is centered in the sight housing.
 - b. Fire four 5-round groups at a target at 100 m.
 - c. Adjust the front sight for elevation and the rear sight for deflection as required to move the MPI.

WEAPON	SIGHT	DISTANCE		MPI + POA
		AT	FOR	
C7	Battle	100	200	+ 6 cm
		25	200	- 3 cm
C8	Battle	100	200	+ 7 cm
		25	200	- 3.5

Figure 4-1 Zero Location.

SECTION 3 - EXAMINATION OF THE RIFLE

421. GENERAL

Introduction. Officers and NCO's must know how to examine a rifle efficiently in order to determine that it is being maintained properly.

422. EXAMINATION

1. **Stripping.** The rifle is to be detailed stripped as for comprehensive cleaning.
2. **Magazine Assembly.** Visually inspect:
 - a. Magazine box for cracks and chipped lips;
 - b. Base plate retaining tabs;
 - c. Rear of follower for chips or excessive wear; and
 - d. Spring for corrosion and proper assembly to follower.
3. **Upper Receiver Group.** Inspect for cracks and small dents which would affect function.

- a. Handguard Assembly. Inspect for cracks, separation of handguard from liner, and check the slip ring for adequate tension.
 - b. Barrel. Check for rust, cuts, bulging and fouling.
 - (1) Pull the barrel through; rust will show on the flannelette or as dark patches in the barrel.
 - (2) A cut looks like a short hair.
 - (3) A bulge shows as a dark circle.
 - (4) Metallic fouling shows as streaks or patches on the lands or in the grooves near the muzzle.
 - (5) Check the outer surface for cracks and other defects.
 - c. Barrel Extension. Check for burrs and broken or worn locking lugs.
 - d. Sights and Gas Tube
 - (1) Check that the front sight is not bent.
 - (2) Check the front sight post and detent for rust.
 - (3) Check the gas tube for cracks, dents or eccentric (irregular) wear at the rear tip.
 - e. Ejection Port Cover Assembly. Check for a bent, twisted or dented cover and broken cover spring.
 - f. Forward Assist. Check for corrosion and free function.
4. Bolt Carrier Group
- a. Check for cracks or deformities in bolt (cam pin hole).
 - b. Inspect bolt for pitting and chipped face.
 - c. Inspect the locking lugs for cracks.
 - d. Check the bolt carrier and key for cracks, rust, burrs and excessive fouling in the key base.

- e. Check extractor and ejector for cracks and chipping, test their springs for tension.
- f. The firing pin should be well rounded.

5. **Lower Receiver Group**

- a. Inspect for cracks, corrosion and dents.
- b. Check magazine and bolt catch for proper functioning.
- c. Inspect butt for cracks and that the butt trap catch functions properly.
- d. Check the pistol grip for cracks and that it is properly secured.
- e. Check rear sight for proper function and rust.

6. **Trigger Mechanism (Rifle Assembled)**

- a. Cock the rifle, place the selector lever on "S" and squeeze the trigger; the hammer should not move.
- b. Place the selector lever on "R", press to trigger and hold it there; the hammer should go forward. Cock the rifle, the hammer should stay down; check by releasing the trigger and then squeezing it.
- c. Cock the rifle, place the selector lever on "AUTO"; squeeze the trigger and hold it there. The hammer should go forward. Cock the rifle, the hammer should move forward. Check by releasing the trigger and then squeezing it.

SECTION 4 - NIGHT FIRING

423. **GENERAL**

- 1. **Safety.** For the safe conduct of night firing on any range it is necessary that the light level be sufficient for the firer to distinguish

his firing lane and the target outline from its background. The conducting officer and supervisors must be able to see sufficiently well to control the actions of the firers and, if necessary, correct weapon handling.

2. The maximum range of engagement permitted will depend on:
 - a. type of weapon,
 - b. type of ammunition,
 - c. weather conditions (limit of night visibility - LNV),
 - d. capability of the night sight, and
 - e. means of illumination (mortar/trip flare, artificial light, etc.).
3. **Limit of Night Visibility.** There are two methods of establishing the limit of night visibility (LNV).
 - a. Fixed Target Locations. From the target line dress back until a point is reached where the targets cannot be seen. Advance towards the targets 5 metres and establish the firing point.
 - b. Fixed Firing Point. Send a man forward along the firing line until he reaches the point at which he cannot be seen, order **STOP**, move him towards the firing point by 5 metres and establish the "stick in target" line at that point. The limit is based on the level of light at the time of measurement. It will be necessary to re-examine the distance during the course of shooting and possibly move the targets or firing line. This would particularly apply if any form of competition was in progress.

(426 to 499 Inclusive: Not Allocated)

CHAPTER 5
RANGE PRACTICES
GENERAL

501. INTRODUCTION

1. All range practices should be conducted as an extension of previously taught lessons. Prior to any live firing commanders should examine the aim of the range practices to be conducted and review the appropriate lessons.
2. Range practices for the C7 rifle and C8 carbine are contained in Annexes A and B respectively. Grouping standards are at Annex C.

502. AIM

Live fire range practices are designed to confirm and assess the basic skills of the firer in target engagement by day and by night.

503. GENERAL

1. Stores. A standard set of stores required for every range practice includes:

a. Rifles/carbines	1 per soldier
b. Ear defenders	1 per soldier
c. First aid kit	1
d. Binoculars	1 per coach
e. Cleaning materials	as required
f. Targets	as required
g. Ammunition	as required
h. Empty sandbags (for casings)	as required
j. Filled sandbags	as required

2. Additional stores, targets and ammunition required are listed with each practice.
3. **Preparation**
 - a. Prior to the day of firing:
 - (1) book the range and confirm the booking and the targets required;
 - (2) read Range Standing Orders;
 - (3) indent for ammunition;
 - (4) identify review lessons; and
 - (5) reconnoitre the range allotted for the range practice.
 - b. On the day of firing:
 - (1) check each soldier for ear defenders; and
 - (2) prepare rifles for firing.
4. **Miscellaneous.** All range staff are to be fully conversant with the details in Chapter 4 - Coaching Techniques.
5. **Safety Precautions**
 - a. Normal safety precautions as applicable to the range being used.
 - b. All range staff are to be fully conversant with the information contained in B-GL-304-03/TS-001 Operational Training. Volume 3, Ranges and Training Safety and applicable Range Standing Orders.

(504 to 599 inclusive: Not allocated)

C7 RIFLE

SUMMARY OF RANGE PRACTICES

APPX	PRACTICE	RANGE (METRES)	RDS	AIM
1	Grouping Prone Supported	20	20	To confirm the firer can aim, hold, and fire in the prone position.
2	Grouping Other Positions	20	30	To confirm the firer can group accurately from the kneeling, sitting, and standing positions.
3	Grouping All Positions	100	40	To determine the firer's grouping ability in the prone, kneeling, sitting and standing positions.
4	Zeroing	100	30	To superimpose the firer's Mean Point of Impact (MPI) onto the Correct Zero Position (CZP).
5	Elementary Application	100 200 300	60/40	To practise the firer in engaging targets by deliberate fire at ranges of 100, 200 and 300 metres from various firing positions. (Infantry only at 300)
6	Advanced Application Rapid and Snapshooting	100 200 300	50/36	To practise the firer in taking up a fire position and engaging targets by rapid and snapshooting at ranges of 100, 200 and 300 metres. (Infantry only at 300)
7	Elementary Application (Bursts)	25 50 75 100	60	To practise the firer in taking up a fire position and engaging targets by bursts at ranges of 25, 50, 75 and 100 metres.
8	Advanced Application Firing at Crossing Targets	25 50 200	78/66	To practise the methods of engaging targets using hand-held targets on a gallery range, (Infantry only at 200).
9	Introduction to Night Shooting	LNV	24	To teach the techniques of firing at night and methods to be used for daylight practice of these techniques.
10	Night Shooting with Illumina-	100 50	30	To practise firing using artificial illumination. (Hand-held flares or light mortars)

RANGE PRACTICE 1. C7 GROUPING PRONE SUPPORTED

AIM: To confirm the firer can aim, hold and fire in the prone position.

SER	PRACTICE	TARGET	RANGE	RDS	INSTRUCTION	SCORE	REMARKS
1.	Grouping	Two 25 m aiming marks super-imposed on a suitable background	20 m	20	a. Prone supported. b. Fire a 5 round group at each aiming mark. c. Discuss groups and repeat.		

NOTES: 1. To enable firers and coaches to gain the maximum information from the shots fired, members of waiting relays should be employed with binoculars to spot the location of each shot.
 2. Firers who do not attain the required standard are to be given further coaching before being allowed to fire again.
 3. Standards. See Annex C.

RANGE PRACTICE 2. C7 GROUPING OTHER POSITIONS AT 20 M

AIM: To confirm the firer can group accurately from the kneeling, sitting and standing positions.

SER	PRACTICE	TARGET	RANGE	RDS	INSTRUCTION	SCORE	REMARKS
1.	Grouping Sitting	Two 25 m aiming marks superimposed on a suit- able background	20 m	10	Firers to fire a 5 round group at each aiming mark.		Firers are to be coached and each group measured and discussed after completion of the serial.
2.	Grouping Kneeling Supported	As Ser 1	20 m	10	As Serial 1.		As Serial 1.
3.	Grouping Standing	As Ser 1	20 m	10	As Serial 1.		As Serial 1.

NOTES: 1. To enable firers and coaches to gain the maximum information from the shots fired, members of waiting relays should be employed with binoculars to spot the arrival of each shot.
 2. Firers who do not attain the required standard are to be given further coaching before being allowed to fire again.
 3. Standards. See Annex C.

RANGE PRACTICE 3. C7 GROUPING ALL POSITIONS AT 100 M

AIM: To determine the firer's grouping ability in the prone, kneeling, sitting and standing positions.

SER	PRACTICE	TARGET	RANGE	RDS	INSTRUCTION	SCORE	REMARKS
1.	Grouping Prone Supported	1.3 metre screen with a Fig 11 target superimposed	100	10	a. Fire a 5 round group at the target. b. Discuss the group and repeat.		The Fig 11 Target is to have a 100 x 75 mm white aiming mark superimposed on the centre.
2.	Grouping Kneeling Supported	As Ser 1	100	10	As Serial 1.		
3.	Grouping Sitting	As Ser 1	100	10	As Serial 1.		
4.	Grouping Standing	As Ser 1	100	10	As serial 1.		

NOTES: 1. Firers who do not attain the required standard are to given further coaching, before being allowed to fire again.
 2. Standards. See Annex C.

RANGE PRACTICE 4. C7 ZEROING AT 100 M

AIM: To superimpose the firer's Mean Point of Impact (MPI) onto the Correct Zero Position (CZP).

SER	PRACTICE	TARGET	RANGE	RDS	INSTRUCTION	SCORE	REMARKS
1.	Grouping Prone Supported	One Fig 11 superimposed on a 1.3 m screen with a suitable white aiming mark	100	15	a. Fire three 5 round groups at the same aiming mark. b. Stand up and move about between each group. c. Identify the MPI and adjust for zero. d. Patch the target.	Nil	a. Firers must have achieved a 200 mm group size in Range Practice 3 before commencing this shoot. b. Firers will not be expected to achieve a 200 mm group size in this range practice with 15 rds. It is likely the 15 rd group will increase to about 250 mm due to the random dispersal of the three groups. However, this concern is only with the position of the MPI of 15 rds.
2.	Confirmation Grouping Prone Supported	As Ser 1	As Ser 1	5	a. Fire one 5 round group to confirm zero.	Nil	
3.	Grouping Kneeling Supported	Two Fig 11 superimposed on a 1.3 m screen with a suitable white aiming mark or stan- dard zeroing targets.	As Ser 1	5	a. Fire one 5 round group at the left target. b. Note any aim off required from MPI for prone position.	Nil	
4.	Grouping Standing Unsupported	As Ser 3	As Ser 1	5	a. Fire one 5 round group at the right target. b. Note any aim off required from MPI for prone position.	Nil	
NOTE: The CZP at 100 m for 200 m is 6 cm above the POA							

RANGE PRACTICE 5. C7 ELEMENTARY APPLICATION

AIM: To practise the firer in engaging targets by deliberate fire at ranges of 100, 200 and 300 metres from various firing positions (Infantry only at 300 m).

SER	PRACTICE	TARGET	RANGE	RDS	INSTRUCTION	SCORE	REMARKS
1.	Application	Fig 12 on a 1.3 metre screen with two inscribed circles of 750 mm and 1.3 metres.	100	10	a. Five rounds to be fired first in the standing position and then repeated in the kneeling unsupported position on a clean target. b. No time limit.	HPS 40	Each shot to be signalled.
2.	Application	One Fig 12	100	10	As Serial 1.	HPS 40	As Serial 1.
3.	Application	Fig 11 on a 1.3 metre screen with two inscribed circles of 750 mm and 1.3 metres.	200	10	a. Five rounds to be fired first in the prone supported position and then repeated in the kneeling/sitting supported position on a clean target. b. No time limit.	HPS 40	As Serial 1.
4.	Application	One Fig 11	200	10	As Serial 3.	HPS 40	As Serial 1.
5.	Application	As Serial 3	300	10	a. Five rounds to be fired first in the prone supported position and then repeated in the fire trench supported position on a clean target.	HPS 40	a. As Serial 1. b. Infantry only.
6.	Application	As Serial 4	300	10	As for Serial 5.	HPS 40	a. As Serial 1. b. Infantry only.

NOTES:

- Each shot location and value to be signalled.
 - Infantry only to fire practices 5 & 6.
 - Scoring:
 - Practices 1, 3 and 5
 - Hits on figure within the 750 mm circle - 4 points
 - Hits on the 750 mm circle off the figure - 2 points
 - Hits within the 1.3 metre circle - 1 point
 - Practices 2, 4 and 6 four points per hit.
 - Standards:
 - Pass Infantry 168 points (70% HPS)
 - Pass Others 112 points (70% HPS)
- c. Highest possible score (HPS)
 Inf 240
 Others 160

RANGE PRACTICE 6. C7 ADVANCED APPLICATION RAPID AND SNAPSHOTTING

AIM: To practise the firer in taking up a fire position and engaging targets by rapid and snapshotting at ranges of 100, 200 and 300 metres (Infantry only at 300 m).

SER	PRACTICE	TARGET	RANGE	RDS	INSTRUCTION	SCORE	REMARKS
1.	Kneeling Unsupported or Squatting	Fig 12 in the target frame.	100	4	a. Firers are 50 m behind the firing point, standing, rifles at the trail. b. Order "KNEELING UNSUP- PORTED WATCH & SHOOT". c. When the targets appear the firers run to the firing point, adopt the nominated position, cock the rifle and fire 4 rounds.	HPS 4	One exposure of 25 seconds.
2.	Standing	Fig 12 hand-held	100	4	a. Order "STANDING POSITION WATCH & SHOOT". b. The firers fire 1 round at each exposure.	HPS 4	a. Four exposures of 5 seconds with irregular intervals between exposures. b. Targets are to be brought down when hit.
3.	Prone Unsupported	As for Serial 2	100	6	a. Firers are to be in the prone unsupported position Order "WATCH & SHOOT". b. The firers fire 1 round at each exposure.	HPS 6	a. Six exposures of 4 seconds with irregular intervals between exposures. b. Targets are to be brought down when hit.

RANGE PRACTICE 6. C7 ADVANCED APPLICATION RAPID AND SNAPSHOTTING

SER	PRACTICE	TARGET	RANGE	RDS	INSTRUCTION	SCORE	REMARKS
4.	Kneeling Supported or Squatting	Fig 11 Hand-held	200	2	a. Firearms stand at the back of the firing point rifles prepared to fire, selector lever on Safe. b. Nominate the firing position order "WATCH AND SHOOT". c. When the target appears the firers move forward on the firing point, adopt the nominated position, and fire one round at each exposure. d. After each double exposure order "APPLY SELECTOR LEVERS - STAND-UP DRESS BACK".	HPS 6	a. Exposures (1) 8 and 4 seconds (2) 8 and 4 seconds (3) 10 and 4 seconds b. Three seconds between exposures. No time limit between positions. c. Targets are to be brought down when hit.
5.	Sitting	Fig 11 in the target frame	200	6	a. Firearms are to be in the sitting position order "WATCH AND SHOOT". b. The firers fire 6 rounds.	HPS 6	a. One exposure of 18 seconds. b. Targets do not come down when hit.
6.	Fire Trench Supported	As Serial 4	200	6	Firems are to be in the fire trench.	HPS 6	a. Six exposures of 4 seconds with irregular intervals between exposures. b. Targets down when hit.

RANGE PRACTICE 6. C7 ADVANCED APPLICATION RAPID AND SNAPSHOTTING

SER	PRACTICE	TARGET	RANGE	RDS	INSTRUCTION	SCORE	REMARKS
7.	Prone Unsupported	As Serial 4	200	4	a. Fireers are to be in the prone unsupported position. Order "WATCH & SHOOT". b. Fireers fire 1 round at each exposure.	HPS 4	a. Four exposures of 4 seconds with irregular intervals between exposures. b. Targets are to be brought down when hit.
8.	Prone Supported	As Serial 4	300	4	a. Fireers are to be in the prone supported position. Order. "WATCH & SHOOT". b. Fireers fire 1 round at each exposure.	HPS 4	a. Four exposures of 4 seconds with irregular intervals between exposures. b. Targets are to be brought down when hit. c. Infantry only.
9.	Fire Trench Supported or Prone Supported if trench not available.	As Serial 4	300	10	a. Fireers are to load initially with a magazine containing 6 rounds and have a magazine of 4 rounds in the pouch. b. No warning to change magazines is to be given c. Fireers are to be in the fire trench. Order "WATCH & SHOOT". d. Fireers are to fire 1 round at each exposure.	HPS 10	a. Ten exposures of 4 seconds with irregular intervals between exposures. b. Targets are to be brought down when hit. c. Infantry only.

NOTES:

- Scoring Infantry.
 - On all practices one point per hit.
 - HPS 50 points.
 - Pass 35 points (70% of HPS).
- Scoring Other Arms.
 - On all practices one point per hit.
 - HPS 36 points.
 - Pass 25 points (70% of HPS).
- The Butt Party should be thoroughly rehearsed.
 - It is important that all targets be held at the proper height. To assist in this a reference mark should be placed on the target stick.
 - The commander of the Butt Party should use a time chart.
 - Infantry only to fire practices 8 & 9.

RANGE PRACTICE 7. C7 ELEMENTARY APPLICATION BURSTS

AIM: To practise the firer in taking up a fire position and engaging targets by bursts.

SER	PRACTICE	TARGET	RANGE	RDS	INSTRUCTION	SCORE	REMARKS
1.	Prone Unsupported Bursts	One Fig 11	100	10	a. Firers are in the prone unsupported "ALERT" position. Order "PRONE-BURSTS-WATCH AND SHOOT". b. Firers fire 3 bursts when the target appears.	HPS 1	One exposure of 8 seconds.
2.	Kneeling Unsupported Bursts	One Fig 11	75	20	a. Firers are to be in the kneeling unsupported position. Order "KNEELING-BURSTS-WATCH AND SHOOT". b. Firers fire 3 or 4 bursts per exposure.	HPS 2	Two exposures of 8 seconds each.
3.	Standing Shoulder	One Fig 11	50	20	a. Firers are in the standing "ALERT" position. Order "STANDING-SHOULDER-BURSTS-WATCH AND SHOOT". b. Firers fire 3 or 4 bursts per exposure.	HPS 2	Two exposures of 8 seconds each.
4.	Standing Hip	One Fig 11	25	10	a. Firers are in the standing position. Order "STANDING-HIP-BURSTS-WATCH AND SHOOT". b. Firers fire 3 bursts when the target appears.	HPS 1	One exposure of 8 seconds each.

NOTES:

1. Scoring.
 - a. A successful target engagement is 1 or more hits on each target exposure.
 - b. 1 point per successful target engagement.

RANGE PRACTICE 8. C7 ADVANCED APPLICATION FIRING AT CROSSING TARGETS

AIM: To practise the methods of engaging crossing targets using hand held targets on a gallery range.

SER	PRACTICE	TARGET	RANGE	RDS	INSTRUCTION	SCORE	REMARKS
1.	Application Bursts	Fig 20 Hand-held	25	10	a. Firers are to be in the standing position. Order "BURSTS-HIP-WATCH AND SHOOT". b. Once the target appears fire three bursts from the hip.	HPS 2	a. One exposure. b. Coaches are to be used. c. After the run, targets are to be exposed in the centre of the run with a spotting disc indicating MPI.
2.	Application Bursts	Fig 20 Hand-held	50	20	a. Firers are to be in the standing position. Order "BURSTS-SHOULDER-WATCH AND SHOOT". b. Once the target appears fire two or three bursts per run.	HPS 4	a. Two exposures, the start of the run is to be from a different end each time. b. Coaches are to be used. c. Targets are brought down when hit. d. After each run, targets are to be exposed in the centre of the run with a spotting disc to indicate MPI.
3.	Application Standing	Fig 20 Hand-held	50	6	a. Firers are to be in the standing "ALERT" position. Order "WATCH & SHOOT". b. Once the target appears fire 1 to 3 shots per run of the target. c. Firers are to adopt the "ALERT" position after each run.	Nil	a. Two exposures, the start of the run is to be from a different end each time. b. Coaches are to be used. c. Targets are brought down when hit. d. After each run, targets are to be exposed in the centre of the run with a spotting disc to assist the coach and firer in assessing the lead used by the firer.
4.	Application Standing	As Serial 3	50	6	As Serial 3.	2 points per successful engagement HPS 4	a. Two exposures. b. Targets are to be brought down when hit. c. Coaches are to be used.
5.	Application Standing	As Serial 3	75	6	As Serial 3.	Nil	As Serial 3.
6.	Application Standing	As Serial 3	75	6	As Serial 3.	As Serial 4 HPS 4	As Serial 4.

RANGE PRACTICE 8. C7 ADVANCED APPLICATION FIRING AT CROSSING TARGETS

SER	PRACTICE	TARGET	RANGE	RDS	INSTRUCTION	SCORE	REMARKS
7.	Application Kneeling Unsupported	As Serial 3	100	6	a. Firers are to be in the kneeling unsupported "ALERT" position. Order "WATCH & SHOOT". b. Once the target appears fire 1 to 3 shots per run of the target. c. Firers are to adopt the "ALERT" position after each run.	Nil	As Serial 3.
8.	Application Kneeling Unsupported	As Serial 3	100	6	As Serial 7.	As Serial 4 HPS 4	As Serial 4.
9.	Application Prone Unsupported	As Serial 3	200	6	a. Firers are to be in the prone unsupported "ALERT" position. Order "WATCH & SHOOT". b. Once the target appears fire 1 to 3 shots per run of the target. c. Firers are to adopt the "ALERT" position after each run.	Nil	As Serial 3.
10.	Application Prone Unsupported	As Serial 3	200	6	As Serial 9.	As Serial 4 HPS 4	As Serial 4.

NOTES: 1. This practice may be conducted on a conventional range, using hand-held targets moved along the gallery by the butt party.
 2. Target speed approximately 1 metre per second.
 3. Distance of target movement is measured from centre to centre of target frame.
 4. A successful target engagement is 1 or more hits on each target exposure.
 5. Safety
 a. An increased danger area is to be applied to range danger area and approval must be given by Range Control.
 b. Due to increased danger area the first three and last three firing positions on firing point must not be used.
 c. The target should move through no more than 5 butt positions, for example; firing point No. 9 engages targets moving from target No. 7 to target No. 11.
 d. On ranges where the use of tracer ammunition is permitted, allow the use of tracer on the first run of Serials 3, 5, 7 and 9.
 6. Scoring.
 a. 2 points per successful target engagement.
 b. Infantry only fire serials 9 and 10.
 c. Infantry HPS 22 Pass 70% = 15.
 d. Other Arms HPS 18 Pass 50% = 9.

RANGE PRACTICE 9. C7 INTRODUCTION TO NIGHT SHOOTING

AIM: To teach the techniques of firing at night and methods to be used for daylight practice of these techniques.

SER	PRACTICE	TARGET	RANGE	RDS	INSTRUCTION	SCORE	REMARKS
1.	Daylight Prone Unsupported	One Fig 11	Estimated Limit of Night Vision (LNV)	6	a. Fireers are to fire 6 rounds, double tap. b. Assess the grouping. c. No time limit.	Nil	
2.	Darkness Prone Unsupported	One Fig 11 draped with hessian.	LNV	12	a. As Serial 1. b. Repeat the practice. c. Record the scores.	One point per hit. HPS 12	
3.	Darkness Kneeling Unsupported	As Serial 2.	As Serial 2.	6	a. Three exposures of 4 seconds. b. Fireers are to fire 2 rounds at each exposure. c. Record the scores.	One point per hit. HPS 6	

NOTES:

1. Training in night shooting should not be rushed. Good coaching is as important at night as it is by day.
2. Strict discipline is necessary for control at night. All parties moving into or out of the butts or to and from the targets must be accounted for and the Range Safety Officer informed.
3. Flashlights used to check weapons and targets should be fitted with red filters.
4. Timed exposures can be controlled by whistle blasts.
5. Fig 11 targets are to be stuck into the ground with the bottom of the target touching the ground. They should be positioned between firing points and draped with hessian for Serials 2 & 3. Targets should be scored using chalk.
6. Serial 1 should be fired in daylight using night firing techniques. It should be used as a rehearsal for Serials 2 and 3.
7. 30 minutes should be allowed at night for fireers to adapt their night vision.
8. This shoot could be conducted with Range Practice 10.
9. Scoring
 - a. Serials 2 & 3 only - one point per hit
 - b. HPS = 18 points Standard
10. a. Pass = 50% = 9 points

RANGE PRACTICE 10. C7 NIGHT SHOOTING WITH ILLUMINATION

AIM: To practise firing using artificial illumination. (Hand held flares or Light Mortar illuminating bombs)

SER	PRACTICE	TARGET	RANGE	RDS	INSTRUCTION	SCORE	REMARKS
1.	Prone Unsupported or Fire Trench.	One Fig 11	100 m	4	a. Order "WATCH & SHOOT". b. Firers are to fire 4 rounds during the illumination of the target.	Nil	This serial is used as a teaching serial and is not scored.
2.	Prone Unsupported or Fire Trench.	One Fig 11	100 m	6	a. As for Serial 1. b. Firers are to fire 6 rounds.	One point per hit. HPS 6	
3.	Standing Shoulder Bursts	One Fig 11	50 m	10	a. Firers are standing. b. Order "BURSTS-SHOULDER-WATCH & SHOOT". c. Firers are to fire 3 bursts during the illumination of the target.	One point per successful engagement HPS 1	
4.	Standing Hip Bursts	One Fig 11	25 m	10	a. Firers are standing. b. Order "BURSTS-HIP-WATCH AND SHOOT". c. Firers are to fire 3 bursts during the illumination of the target.	As Serial 3.	

NOTES:

1. Firers should be able to shoot almost as accurately at night with artificial illumination as they can in daylight.
2. It is possible to use the iron sights as in daylight and this method should be encouraged.
3. Firers cannot expect to see a perfect sight picture since artificial light produces strong shadows and often makes the target more difficult to see. It is wrong for firers to delay firing in hope that the light will improve.
4. Firers should close one eye as an immediate reaction to artificial light in order to protect some night vision while still aiming to fire the rifle. Service illuminants do not seriously affect night vision and adaption usually returns within five seconds of the return of darkness.
5. This shoot could be conducted with Range Practice 9.
6. Scoring: a. Serial 2 = 1 point per hit.
b. Serials 3 & 4 = 1 point per successful target engagement.
c. HPS = 8.
7. Standard. Pass = 50% (4 points).

C8 CARBINE

SUMMARY OF RANGE PRACTICES

APPX	PRACTICE	RANGE (METRES)	RDS	AIM
1	Grouping Prone Supported	20	20	To confirm the firer can aim, hold, and fire in the prone position.
2	Grouping Other Positions	20	30	To confirm the firer can group accurately from kneeling, sitting, and standing positions.
3	Grouping All Positions	100	40	To determine the firer's grouping ability in the prone, kneeling, sitting and standing positions.
4	Zeroing	100	30	To superimpose the firer's Mean Point of Impact (MPI) onto the Correct Zero Position (CZP).
5	Elementary Application	100 200	40	To practise the firer in engaging targets by deliberate fire at ranges of 100 and 200 metres from various firing positions.
6	Advanced Application Rapid and Snapshooting	100 200	36	To practise the firer in taking up a fire position and engaging targets by rapid and snapshooting at ranges of 100 and 200 metres.
7	Elementary Application (Bursts)	25 50 75 100	60	To practise the firer in taking up a fire position and engaging targets by bursts at ranges of 25, 50, 75 and 100 metres.
8	Advanced Application Firing at Crossing Targets	25 50 75 100	66	To practise the methods of engaging targets using hand-held targets on a gallery range.
9	Introduction to Night Shooting	LNV	24	To teach the techniques of firing at night and methods to be used for daylight practice of these techniques.
10	Night Shooting with Illumination	100 50 25	30	To practise firing using artificial illumination. (Hand-held flares or light mortars).

RANGE PRACTICE 1. C8 GROUPING PRONE SUPPORTED

AIM: To confirm the firer can aim, hold and fire in the prone position.

SER	PRACTICE	TARGET	RANGE	RDS	INSTRUCTION	SCORE	REMARKS
1.	Grouping	Two 25 m aiming marks super-imposed on a suitable background	25 m	20	a. Prone supported. b. Fire a 5 round group at each aiming mark. c. Discuss groups and repeat.		

NOTES: 1. To enable firers and coaches to gain the maximum information from the shots fired, members of waiting relays should be employed with binoculars to spot the location of each shot.
 2. Firers who do not attain the required standards are to be given further coaching before being allowed to fire again.
 3. Standards. See Annex C.

RANGE PRACTICE 2. C8 GROUPING OTHER POSITIONS AT 20 M

AIM: To confirm the firer can group accurately from the kneeling, sitting and standing positions.

SER	PRACTICE	TARGET	RANGE	RDS	INSTRUCTION	SCORE	REMARKS
1.	Grouping Sitting	Two 25 m aiming marks superimposed on a suitable background	20 m	10	Firers to fire a 5 round group at each aiming mark.		Firers are to be coached and each group measured and discussed after completion of the serial.
2.	Grouping Kneeling Supported	As Ser 1	20 m	10	As Serial 1.		As Serial 1.
3.	Grouping Standing	As Ser 1	20 m	10	As Serial 1.		As Serial 1.

NOTES: 1. To enable firers and coaches to gain the maximum information from the shots fired, members of waiting relays should be employed with binoculars to spot the arrival of each shot.
 2. Firers who do not attain the required standard are to be given further coaching before being allowed to fire again.
 3. Standards. See Annex C.

RANGE PRACTICE 3. C8 GROUPING ALL POSITIONS AT 100 M

AIM: To determine the firer's grouping ability in the prone, kneeling, sitting and standing positions.

SER	PRACTICE	TARGET	RANGE	RDS	INSTRUCTION	SCORE	REMARKS
1.	Grouping Prone Supported	1.3 metre screen with a Fig 11 target superimposed	100	10	a. Fire a 5 round group at the target. b. Discuss the group and repeat.		The Fig 11 target is to have a 100 x 75 mm white aiming mark superimposed on the centre.
2.	Grouping Kneeling Supported	As Ser 1	100	10	As Serial 1.		
3.	Grouping Sitting	As Ser 1	100	10	As Serial 1.		
4.	Grouping Standing	As Ser 1	100	10	As serial 1.		

NOTES: 1. Firers who do not attain the required standard are to be given further coaching, before being allowed to fire again.
 2. Standards. See Annex C.

RANGE PRACTICE 5. C8 ELEMENTARY APPLICATION

AIM: To practise the firer in engaging targets by deliberate fire at ranges of 100 and 200 metres from various firing positions.

SER	PRACTICE	TARGET	RANGE	RDS	INSTRUCTION	SCORE	REMARKS
1.	Application	Fig 12 on a 1.3 metre screen with two inscribed circles of 750 mm and 1.3 metres.	100	10	a. Five rounds to be fired first in the standing position and then repeated in the kneeling unsupported position on a clean target. b. No time limit.	HPS 40	Each shot to be signalled.
2.	Application	One Fig 12	100	10	As Serial 1.	HPS 40	As Serial 1.
3.	Application	Fig 11 on a 1.3 metre screen with two inscribed circles of 750 mm and 1.3 metres.	200	10	a. Five rounds to be fired first in the prone supported position and then repeated in the kneeling/sitting supported position on a clean target. b. No time limit.	HPS 40	As Serial 1.
4.	Application	One Fig 11	200	10	As Serial 3.	HPS 40	As Serial 1.

NOTES:

1. Each shot location and value to be signalled.
2. Scoring:
 - a. Practices 1 and 3
 - (1) Hits on figure within the 750 mm circle - 4 points
 - (2) Hits on the 750 mm circle off the figure - 2 points
 - (3) Hits within the 1.3 metre circle - 1 point
 - b. Practices 2 and 4
 - four points per hit.
4. Standards:
 - a. Pass 112 points (70% HPS)
 - c. HPS 160

RANGE PRACTICE 6. C8 ADVANCED APPLICATION RAPID AND SNAPSHOTTING

AIM: To practise the firer in taking up a fire position and engaging targets by rapid and snapshotting at ranges of 100 and 200 metres.

SER	PRACTICE	TARGET	RANGE	RDS	INSTRUCTION	SCORE	REMARKS
1.	Kneeling Unsupported or Squatting	Fig 12 in the target frame.	100	4	a. Firers are 50 m behind the firing point, standing, carbines at the trail. b. Order "KNEELING UNSUP- PORTED WATCH & SHOOT". c. When the targets appear the firers run to the firing point, adopt the nominated position, cock the carbine and fire 4 rounds.	HPS 4	One exposure of 25 seconds.
2.	Standing	Fig 12 hand-held	100	4	a. Order "STANDING POSITION WATCH & SHOOT". b. The firers fire 1 round at each exposure.	HPS 4	a. Four exposures of 5 seconds with irregular intervals between exposures. b. Targets are to be brought down when hit.
3.	Prone Unsupported	As for Serial 2	100	6	a. Firers are to be in the prone unsupported position. Order "WATCH & SHOOT". b. The firers fire 1 round at each exposure.	HPS 6	a. Six exposures of 4 seconds with irregular intervals between exposures. b. Targets are to be brought down when hit.

RANGE PRACTICE 6. C8 ADVANCED APPLICATION RAPID AND SNAPSHOTTING

SER	PRACTICE	TARGET	RANGE	RDS	INSTRUCTION	SCORE	REMARKS
4.	Kneeling Supported or Squatting	Fig 11 Hand-held	200	2	a. Firers stand at the back of the firing point carbines prepared to fire selector lever on Safe. b. Nominate the firing position order "WATCH AND SHOOT". c. When the target appears the firers move forward on the firing point, adopt the nominated position, and fire one round at each exposure. d. After each double exposure order "APPLY SELECTOR LEVERS - STAND-UP DRESS BACK".	HPS 6	a. Exposures (1) 8 and 4 seconds (2) 8 and 4 seconds (3) 10 and 4 seconds b. Three seconds between exposures. No time limit between positions. c. Targets are to be brought down when hit.
5.	Sitting	Fig 11 in the target frame	200	6	a. Firers are to be in the sitting position. Order "WATCH AND SHOOT". b. The firers fire 6 rounds.	HPS 6	a. One exposure of 18 seconds. b. Targets do not come down when hit.
6.	Fire Trench Supported	As Serial 4	200	6	Firers are to be in the fire trench.	HPS 6	a. Six exposures of 4 seconds with irregular intervals between exposures. b. Targets down when hit.

RANGE PRACTICE 6. C8 ADVANCED APPLICATION RAPID AND SNAPSHOTTING

SER	PRACTICE	TARGET	RANGE	RDS	INSTRUCTION	SCORE	REMARKS
7.	Prone Unsupported	As Serial 4	200	4	a. Firers are to be in the prone unsupported position. Order "WATCH & SHOOT". b. Firers fire 1 round at each exposure.	HPS 4	a. Four exposures of 4 seconds with irregular intervals between exposures. b. Targets are to be brought down when hit.
NOTES:							
1. Scoring Other Arms. a. On all practices one point per hit. b. HPS 36 points. c. Pass 25 points (70% of HPS).							
2. The Butt Party should be thoroughly rehearsed.							
3. It is important that all targets be held at the proper height. To assist in this a reference mark should be placed on the target stick.							
4. The commander of the Butt Party should use a time chart.							

RANGE PRACTICE 7. C8 ELEMENTARY APPLICATION BURSTS

AIM: To practise the firer in taking up a fire position and engaging targets by bursts.

SER	PRACTICE	TARGET	RANGE	RDS	INSTRUCTION	SCORE	REMARKS
1.	Prone Unsupported Bursts	One Fig 11	100	10	a. Firers are in the prone unsupported "ALERT" position. Order "PRONE-BURSTS-WATCH AND SHOOT". b. Firers fire 3 bursts when the target appears.	HPS 1	One exposure of 8 seconds.
2.	Kneeling Unsupported Bursts	One Fig 11	75	20	a. Firers are to be in the kneeling unsupported position. Order "KNEELING-BURSTS-WATCH AND SHOOT". b. Firers fire 3 or 4 bursts per exposure.	HPS 2	Two exposures of 8 seconds each.
3.	Standing Shoulder	One Fig 11	50	20	a. Firers are in the standing "ALERT" position. Order "STANDING-SHOULDER-BURSTS-WATCH AND SHOOT". b. Firers fire 3 or 4 bursts per exposure.	HPS 2	Two exposures of 8 seconds each.
4.	Standing Hip	One Fig 11	25	10	a. Firers are in the standing position. Order "STANDING-HIP-BURSTS-WATCH AND SHOOT". b. Firers fire 3 bursts when the target appears.	HPS 1	One exposure of 8 seconds each.
NOTES:							
1. Scoring.							
a. A successful target engagement is 1 or more hits on each target exposure.							
b. 1 point per successful target engagement.							

RANGE PRACTICE 8. C8 ADVANCED APPLICATION FIRING AT CROSSING TARGETS

AIM: To practise the methods of engaging crossing targets using hand-held targets on a gallery range.

SER	PRACTICE	TARGET	RANGE	RDS	INSTRUCTION	SCORE	REMARKS
1.	Application Bursts	Fig 20 Hand-held	25	10	a. Firers are to be in the standing position. Order "BURSTS-HIP-WATCH AND SHOOT". b. Once the target appears fire three bursts from the hip.	HPS 2	a. One exposure. b. Coaches are to be used. c. After the run, targets are to be exposed in the centre of the run with a spotting disc indicating MPI.
2.	Application Bursts	Fig 20 Hand-held	50	20	a. Firers are to be in the standing position. Order "BURSTS-SHOULDER-WATCH AND SHOOT". b. Once the target appears fire two or three bursts per run.	HPS 4	a. Two exposures, the start of the run is to be from a different end each time. b. Coaches are to be used. c. Targets are brought down when hit. d. After each run, targets are to be exposed in the centre of the run with a spotting disc to indicate MPI.
3.	Application Standing	Fig 20 Hand-held	50	6	a. Firers are to be in the standing "ALERT" position. Order "WATCH & SHOOT". b. Once the target appears fire 1 to 3 shots per run of the target. c. Firers are to adopt the "ALERT" position after each run.	Nil	a. Two exposures, the start of the run is to be from a different end each time. b. Coaches are to be used. c. Targets are brought down when hit. d. After each run, targets are to be exposed in the centre of the run with a spotting disc to assist the coach and firer in assessing the lead used by the firer.
4.	Application Standing	As Serial 3	50	6	As Serial 3.	2 points per successful engagement HPS 4	a. Two exposures. b. Targets are to be brought down when hit. c. Coaches are to be used.
5.	Application Standing	As Serial 3	75	6	As Serial 3.	Nil	As Serial 3.
6.	Application Standing	As Serial 3	75	6	As Serial 3.	As Serial 4 HPS 4	As Serial 4.

RANGE PRACTICE 8. C8 ADVANCED APPLICATION FIRING AT CROSSING TARGETS

SER	PRACTICE	TARGET	RANGE	RDS	INSTRUCTION	SCORE	REMARKS
7.	Application Kneeling Unsupported	As Serial 3	100	6	a. Firers are to be in the kneeling Unsupported "ALERT" position. Order "WATCH & SHOOT." b. Once the target appears fire 1 to 3 shots per run of the target. c. Firers are to adopt the "ALERT" position after each run.	Nil	As Serial 3.
8.	Application Kneeling Unsupported	As Serial 3	100	6	As Serial 7.	As Serial 4 HPS 4	As Serial 4.

NOTES: 1. This practice may be conducted on a conventional range, using hand-held targets moved along the gallery by the Butt Party.
 2. Target speed approximately 1 metre per second.
 3. Distance of target movement is measured from centre to centre of target frame.
 4. A successful target engagement is 1 or more hits on each target exposure.
 5. Safety
 a. An increased danger area is to be applied to range danger area and approval must be given by Range Control.
 b. Due to increased danger area the first three and last three firing positions on firing point must not be used.
 c. The target should move through no more than 5 butt positions, for example; firing point No. 9 engages targets moving from target No. 7 to target No. 11.
 d. On ranges where the use of tracer ammunition is permitted, allow the use of tracer on the first run of Serials 3, 5 and 7.
 6. Scoring.
 a. 2 points per successful target engagement.
 b. HPS 18 Pass 50% = 9.

RANGE PRACTICE 9. C8 INTRODUCTION TO NIGHT SHOOTING

AIM: To teach the techniques of firing at night and methods to be used for daylight practice of these techniques.

SER	PRACTICE	TARGET	RANGE	RDS	INSTRUCTION	SCORE	REMARKS
1.	Daylight Prone Unsupported	One Fig 11	Estimated Limit of Night Vision (LNV)	6	a. Fireers are to fire 6 rounds, double tap. b. Assess the grouping. c. No time limit.	Nil	
2.	Darkness Prone Unsupported	One Fig 11 draped with hessian.	LNV	12	a. As Serial 1. b. Repeat the practice. c. Record the scores.	One point per hit. HPS 12	
3.	Darkness Kneeling Unsupported	As Serial 2.	As Serial 2.	6	a. Three exposures of 4 seconds. b. Fireers are to fire 2 rounds at each exposure. c. Record the scores.	One point per hit. HPS 6	

NOTES:

1. Training in night shooting should not be rushed. Good coaching is as important at night as it is by day. See Chapter 4, Section 4.
2. Strict discipline is necessary for control at night. All parties moving into or out of the butts or to and from the targets must be accounted for and the Range Safety Officer informed.
3. Flashlights used to check weapons and targets should be fitted with red filters.
4. Timed exposures can be controlled by whistle blasts.
5. Fig 11 Targets are to be stuck into the ground with the bottom of the target touching the ground. They should be positioned between firing points and draped with hessian for Serials 2 & 3. Targets should be scored using chalk.
6. Serial 1 should be fired in daylight using night firing techniques. It should be used as a rehearsal for Serials 2 and 3.
7. 30 minutes should be allowed at night for fireers to adapt their night vision.
8. This shoot could be conducted with Range Practice 10.
9. Scoring
 - a. Serials 2 & 3 only - one point per hit
 - b. HPS = 18 points
10. Standard
 - a. Pass = 50% = 9 points

RANGE PRACTICE 10. C8 NIGHT SHOOTING WITH ILLUMINATION

AIM: To practise night firing using artificial illumination. (Hand-held flares or light mortar illuminating bombs)

SER	PRACTICE	TARGET	RANGE	RDS	INSTRUCTION	SCORE	REMARKS
1.	Prone Unsupported or Fire Trench.	One Fig 11	100 m	4	a. Order "WATCH & SHOOT". b. Firers are to fire 4 rounds during the illumination of the target.	Nil	This serial is used as a teaching serial and is not scored.
2.	Prone Unsupported or Fire Trench.	One Fig 11	100 m	6	a. As for Serial 1. b. Firers are to fire 6 rounds.	One point per hit. HPS 6	
3.	Standing Shoulder Bursts	One Fig 11	50 m	10	a. Firers are in the standing position. b. Order "BURSTS-SHOULDER-WATCH & SHOOT". c. Firers are to fire 3 bursts during the illumination of the target.	One point per successful engagement HPS 1	
4.	Standing Hip Bursts	One Fig 11	25 m	10	a. Firers are in the standing position. b. Order "BURSTS-HIP-WATCH AND SHOOT". c. Firers are to fire 3 bursts during the illumination of the target.	As Serial 3.	

NOTES:

1. Firers should be able to shoot almost as accurately at night with artificial illumination as they can in daylight.
2. It is possible to use the iron sights as in daylight and this method should be encouraged.
3. Firers cannot expect to see a perfect sight picture since artificial light produces strong shadows and often makes the target more difficult to see. It is wrong for firers to delay firing in hope that the light will improve.
4. Firers should close one eye as an immediate reaction to artificial light in order to protect some night vision while still aiming to fire the rifle. Service illuminants do not seriously affect night vision and adaption usually returns within five seconds of the return of darkness.
5. This shoot could be conducted with Range Practice 9.
6. Scoring: a. Serial 2 = 1 point per hit.
b. Serials 3 & 4 = 1 point per successful target engagement.
c. HPS = 8.
7. Standard. Pass = 50% (4 points).

CHAPTER 6

TESTS AND STANDARDS

GENERAL

601. INTRODUCTION

1. This chapter details the weapon handling and shooting tests and the standards to be achieved with the rifle and carbine as personal and alternative personal weapons.
2. The tests provide a means for instructors to monitor progress during training and for commanders to assess the standard of training of their troops.
3. Standards should be measured:
 - a. at appropriate stages during training; and
 - b. annually in all units.

602. HANDLING TESTS

1. **Conduct.** The tests are to be done consecutively. They may be conducted:
 - a. in barracks using dummy or blank ammunition or
 - b. on a range using live or blank ammunition.
2. **Dress.** Fighting order, less steel helmet, will be worn for all tests.
3. **Standards.** The following standards will apply
 - a. Skilled - skilled standard in all tests.
 - b. Average - minimum of average in one or more tests.
 - c. Fail - fail in one or more tests.

603. GROUPING STANDARDS

To ensure that a firer has a reasonable chance of passing the personal Weapon Test or Alternative Personal Weapon Assessment, grouping standards should be achieved prior to attempting the tests, see Annex A. If a firer is not grouping to the standard listed it is unlikely that he will pass any of the tests.

(604 to 699 inclusive: Not allocated)

GROUPING STANDARDS C7 and C8

POSN	PERSONAL WEAPON			ALTERNATIVE PERSONAL WEAPON				
	20 m		100 m	20 m		100 m		
	Inf	OA/S	Inf	OA/S	Inf	OA/S		
Prone Sp	25	38	100	150	25	38	100	150
Kneeling Sp	25	38	100	150	25	38	125	175
Sitting	38	56	150	200	56	75	175	225
Standing	75	100	250	250	110	110	300	300

NOTE: OA/S = Other Arms and Services.

HANDLING TESTS - C7 and C8

TEST NO.	SUBJECT	STORES	CONDITIONS	MARKING
(a)	(b)	(c)	(d)	(e)
1	Safety Precautions	Rifle loaded. Selector lever at 'R'. Rifle lying on ground.	Order the soldier to pick up the rifle. The soldier without further direction is to carry out individual safety precautions.	The soldier is awarded FAIL if the safety actions are not carried out properly.
2	Stripping, Cleaning and Assembling	Rifle unloaded. Cleaning kit.	a. Order the soldier to strip the rifle for regular cleaning. b. Order the soldier to assemble the rifle. c. Test after assembling.	a. The purpose of this test is to assess the soldier's ability to strip and assemble the rifle. b. Skilled - No mistakes Average - 1 to 3 mistakes Fail - More than 3 mistakes
3	Magazine filling	30 rounds loose. Stop watch.	a. On the command GO, the man fills the magazine by hand. b. Instructors note: Leave magazine filled.	Skilled - 60 seconds Average - 61-70 seconds Fail - More than 70 seconds, or an incorrectly filled magazine.

HANDLING TESTS - C7 and C8

TEST NO.	SUBJECT	STORES	CONDITIONS	MARKING
(a)	(b)	(c)	(d)	(e)
4	Loading-Standing position	Rifle. One full magazine in fastened pouch. Stop watch.	a. Give the command LOAD and take the time from the command until the soldier has completed the load. b. Pouches must be fastened but this is not included in the time limit. c. Time Limit seven seconds. d. Instructor's note: Leave rifle loaded for test No. 5.	a. Skilled - 7 seconds. Average - 8-12 seconds. Fail - More than 12 seconds or if any mistake effects safety. b. Add 2 seconds to over-all time for each mistake.
5	Immediate Action	Loaded rifle. Targets. Stop watch.	a. Order DOWN. b. Give simple fire orders. c. As soon as the target is engaged give command RIFLE FIRES PROPERLY - RIFLE STOPS - BOLT AT REAR. Firer must carry out Immediate Action, re-aim and fire in 10 seconds. d. While the firer is engaging the target give command RIFLE FIRES PROPERLY - RIFLE STOPS - BOLT FULLY FORWARD. Firer must carry out the Immediate Action, re-aim and fire in 15 seconds. e. While the firer is engaging the target give command RIFLE FIRES PROPERLY - RIFLE STOPS - BOLT CARRIER PARTIALLY FORWARD. Firer must carry out the Immediate Action, re-aim and fire in 20 seconds.	a. Skilled - All actions correct. Average - 1 to 2 mistakes. Fail - More than two mistakes, or if any mistake effects safety.

HANDLING TESTS - C7 and C8

TEST NO.	SUBJECT	STORES	CONDITIONS	MARKING
(a)	(b)	(c)	(d)	(e)
6	Unloading Prone position	Rifle loaded Stop watch	a. This test follows on from Test No. 5. b. Give the command UNLOAD and take the time from the command until the soldier has finished unloading. He is to stand up, recover the ejected round and fasten the pouch, but this is not included in the time limit.	a. Skilled - 9 seconds or less Average - 10 to 15 seconds Fail - more than 15 seconds, or if any mistake effects safety. b. Add 2 seconds to overall time for each mistake.
7	Application of Fire	Figure Targets Map P in	a. Ask the soldier to indicate (using the map pin) five different points of aim using the battle sight. (1) strong wind L to R target distance 300. (2) stationary or head on target distance 300. (3) stationary or head on target distance 100. (4) strong wind R to L, target distance 300. (5) moving target L to R, brisk running pace at 200 m.	a. Skilled - All correct b. Average - 2 correct answers c. Fail - Less than two correct answers
8	Preparation for firing	Rifle. Magazine. Cleaning Kit.	1. Order the soldier to prepare his rifle for firing. Explain that it does require cleaning. Without further direction the soldier should: (1) Carry out regular cleaning. (2) Ensure that the bore, face of the bolt and the chamber are free of lubricant.	a. Skilled - up to two mistakes Average - 3 to 5 mistakes Fail - over 5 mistakes, or if any mistake effects safety.

C7 and C8

PERSONAL WEAPON TEST

SERIAL	PRACTICE	TARGETS	RANGE (METRES)	ROUNDS	POSITION AND FIRER'S INSTRUCTIONS	SCORING	RANGE INSTRUCTIONS
1	Sighting	1.3 m (4 feet) Figure 11 with white aiming mark.	100	5	Firers choice.	Nil	a. No time limit. b. Each round and MPI indicated. c. Provides check on zeroing.
2	Grouping	1.3 m (4 feet) Figure 11 w/aiming mark.	100	5	Prone supported or unsupported (firers choice)	150mm (6-inch) - 5 points 200mm (8-inch) - 3 points HPS - 5	a. No time limit. b. No Indication. c. 5 round group best 4 shots only to count.
3	Application	Figure 11 in target frame.	200	5	Prone unsupported.	One point per hit HPS - 5	a. No time limit. b. Target falls when hit then reappears.
4	Snap shooting	Figure 11 on stick.	200	10	a. Prone unsupported - four rounds. Kneeling supported - six rounds. b. Sight adjusted. Selector lever at 'R'. Rifle out of shoulder after each exposure. c. Two rounds per exposure.	One point per hit HPS - 10	a. One trial exposure. b. Two exposures of 5 seconds + three of 8 seconds interval between exposures not less than 10 seconds. c. Position of target varies at each exposure.

C7 and C8

PERSONAL WEAPON TEST

SER	PRACTICE	TARGETS	RANGE (METRES)	ROUNDS	POSITION AND FIRER'S INSTRUCTIONS	SCORING	RANGE INSTRUCTIONS
5	Rapid fire	Figure 11 in target frame.	200	15	a. Fire trench (if available) or prone supported. b. Rifle loaded with 10 round magazine. Firer may be in aim when target appears. c. Change magazines.	One point per hit HPS - 15	a. No trial exposure. b. Exposure: 40 seconds. c. Hits NOT indicated.
6	Application	Figure 11 in target	300	5	Prone supported	One point per hit. HPS - 5	a. Infantry only. b. C7 only. c. No time limit. d. Target falls when hit then re-appears.
7	Snap shooting	Two Figure 11's in target frame.	300	10	a. Fire trench (prone supported if trench not available). b. Rifle loaded. Selector lever on 'R'. Rifle out of shoulder at start and after each exposure. c. Two rounds at each exposure, one at each target.	One point per hit. HPS - 10	a. Infantry only. b. C7 only. c. One trial exposure. d. Five exposures of five seconds each. Interval between exposures not less than 10 seconds.
8	Fire and Movement		400	28 (2 magazines of 14 rounds each)	a. Preparatory Stage (1) Firer, with two magazines adopts prone position at 400 M and loads. (2) Selector lever on 'S'.	a. One point per hit. b. In Phase 1 and 2 no more than 6 hits count on each target. c. In Phase 3 no more than 4 hits will count on each Figure 12 target. d. In Phase 4 one point per hit for first Figure 11 and Figure 12. and one point for each successful target	a. Preparatory Stage (1) DIC Exercise explains practice after rifles are loaded and selector levers at 'S'. (2) DIC Exercise orders Butt Officer to commence the practice and control target exposure time.

C7 and C8

PERSONAL WEAPON TEST

SER	PRACTICE	TARGETS	RANGE (METRES)	ROUNDS	POSITION AND FIRER'S INSTRUCTIONS	SCORING	RANGE INSTRUCTIONS
		Two Figure 11's in forward target frame.	300	6	<p>b. Phase 1</p> <p>(1) When the target appears, the firer doubles forward, at the trail, to the 300 M firing point and fires three rounds from the prone supported or unsupported position (optional to firer) at each of two Figure 11 targets.</p> <p>(2) Firing will STOP when targets disappear.</p> <p>(3) Selector levers on '5'.</p>	<p>engagement firing bursts, ie, one hit per exposure.</p> <p>e. HPS - 28</p>	<p>b. Phase 1</p> <p>(1) Infantry only.</p> <p>(2) C7 only.</p> <p>(3) Firer advances automatically when targets are exposed.</p> <p>(4) Targets (2 x Figure 11) are exposed for 45 seconds.</p>
		Same targets as Phase 1.	200	8	<p>c. Phase 2</p> <p>(1) When targets appear, the firer doubles forward to 200 M firing point at the trail and fires four rounds from kneeling supported position at each Figure 11.</p> <p>(2) Firing will STOP when targets disappear.</p>		<p>c. Phase 2. After 10 seconds pause two Figure 11 targets are exposed for 45 seconds.</p>

C7 and C8

PERSONAL WEAPON TEST

SER	PRACTICE	TARGETS	RANGE (METRES)	ROUNDS	POSITION AND FIRER'S INSTRUCTIONS	SCORING	RANGE INSTRUCTIONS
					(3) Selector lever on 'S'. Magazines changed when first is empty or when targets disappear.		
		Two Figure 12 in rear target frame	100	8	d. Phase 3 (1) When targets appear, firer doubles forward at the trail to 100 m firing point and fires four rounds from the prone unsupported at each Figure 12 target.		d. Phase 3. After 10 seconds pause two Figure 12 targets are exposed for 45 seconds.
					(2) Firing will STOP when targets go down. Selector lever set on 'S'. STAND UP.		
		One Figure 11 on stick	100	2	e. Phase 4 (1) Commence 10 seconds after end Phase 3. ALERT position. WATCH AND SHOOT. When target appears adopt kneeling unsupported position and fire two rounds at a Figure 11.		e. Phase 4 (1) A pause of 10 seconds is taken from end of last 45-second exposure (Phase 3). (2) One Figure 11 target (on stick) is exposed for 8 seconds. (3) A pause of 35 seconds is taken and a Figure 11 targets is exposed for 5 seconds.

C7 and C8

PERSONAL WEAPON TEST

SERIAL	PRACTICE	TARGETS	RANGE (METRES)	ROUNDS	POSITION AND FIRER'S INSTRUCTIONS	SCORING	RANGE INSTRUCTIONS
					(2) Command. ADVANCE, given 10 seconds after target disappears. Firer moves forward at walk, rifle at ALERT, selector lever at 'S'.		(4) A pause of 25 seconds is taken and a Figure 12 target is exposed for 5 seconds.
		Same target	75	2	(3) Firer walks 25 M stops and fires two rounds from the standing position at Figure 11 when it appears.		(5) A pause of 25 seconds is taken and a Figure 11 target on a stick is exposed for 5 seconds twice.
		One Figure 12 on stick	50	2	(4) When target disappears firer continues to walk in ALERT position about 25 M. stops and fires two rounds from the standing position at Figure 12 when it appears.		Notes: a. Timings for Butt Officer: (1) Phase 1 - Two Figure 11 - 45 seconds (2) Between Phases 1 and 2 - 10 seconds (3) Phase 2 - two Figure 11 - 45 seconds (4) Between Phases 2 and 3 - 10 seconds (5) Phase 3 - two Figure 12 - 45 seconds (6) Between Phases 3 and 4 - 10 seconds (7) Phase 4 - One Figure 11 - 8 seconds. Pause 35 seconds - one Figure 11 - 5 seconds. Pause 25 seconds - one Figure 12 - 5 seconds. Pause 25 seconds - one Figure 11 - 5 seconds. Pause 5 seconds - same Figure 11 - 5 seconds. Dressing must be controlled during this phase.
		One Figure 11 on stick	25	6	(5) When target disappears command ADVANCE, STANDING BURSTS, WATCH AND SHOOT. Firer walks 25 M stops and fires one burst per exposure from the standing shoulder or hip position. (6) Firing will stop when targets go down (98 seconds after ADVANCE).		

C7 and C8

PERSONAL WEAPON TEST

SER	PRACTICE	TARGETS	RANGE (METRES)	ROUNDS	POSITION AND INSTRUCTIONS	FIRER'S INSTRUCTIONS	SCORING	RANGE INSTRUCTIONS
NOTES:								
1. Practices 6, 7 and Phase 1 of Practice 8 are not fired for all C8 Personal Weapon Tests.								
2. Practices 6, 7 and Phase 1 of Practice 8 are not fired for non-infantry C7 Personal Weapon Tests.								
3. Scoring								
a. Infantry C7								
HPS - 78								
MKSM - 66								
PASS - 55								
FAIL - Below 55								
b. Other Arms and Services (OAS) C7								
All Arms and Services C8								
HPS - 57								
MKSM - 48								
PASS - 40								
FAIL - Below 40								
4. A successful target engagement is 1 or more hits on each target exposure.								

C7 and C8

INFANTRY ANNUAL PERSONAL WEAPON TEST

(NIGHT SUPPLEMENT)

SER	PRACTICE	TARGET	RANGE	RDS	INSTRUCTION	SCORE	REMARKS
1	Prone	Draped Figure 11	(LNV) Limit of Night Visibility	10	a. Fire 10 rounds deliberate. b. Examine targets, determine the MPI.	Nil	Use DOUBLE-TAP firing method.
2	Prone	As per Serial 1	LNV	10	a. Order LOAD - WATCH AND SHOOT. b. 5 exposures of 5 seconds each. c. Intervals of 5-10 seconds. d. Fire 2 rounds at each exposure. e. Targets may fall when hit if using MTR.	HPS 10.	As per Serial 1.
3	Prone	As per Serial 1	LNV	10	a. Order LOAD, WATCH & SHOOT. b. One exposure of 20 seconds. c. 10 rounds to be fired. d. Targets do not fall when hit.	HPS 10.	As per Serial 1.

NOTES:

1. This supplement constitutes part of the PWT (Inf only) and is mandatory for all firers regardless of the score achieved during the first portion (daylight practices).
2. When firing at LNV on conventional ranges, strict control over all persons is essential. The conducting officer is to ensure that the conditions for night firing as laid down in CFP 304(3) Ranges and Training Safety along with local Range Standing Orders are complied with.
3. Scoring
 - a. One point per hit HPS 20 points
 - b. Pass mark 50% 10 points
4. A marksman from the daylight practices must achieve a pass in this supplement in order to retain for the marksman qualification. A firer may become a marksman by the addition of his score from the night supplement or he may be granted a pass if the combined score exceeds the pass standard.

C7 and C8

ALL ARMS AND SERVICES

ALTERNATIVE PERSONAL WEAPON ASSESSMENT

SER	PRACTICE	RANGE	RDS	TARGET	SCORE	REMARKS
1	Grouping Prone Supported	100	5	One 1.3 m target screen with a Figure 11 superimposed with a suitable white aiming mark.	Nil.	a. Fire a 5 round group. b. Move down range and examine the target. c. Note the MPI and any change necessary to his point of aim.
2	Grouping Prone Supported	100	5	As per Serial 1.	150mm (6 inch) 1- 5 points 200mm (8 inch) 1- 3 points HPS - 5	a. Fire a 5 round group. b. Butt marker to point out position of MPI. c. This allows confirmation of firers Point of Aim. d. Measure group size best four to count.
3	Grouping Kneeling Supported	100	5	As per Serial 1.	HPS 5	As per Serial 2.
4	Grouping Standing	100	5	As per Serial 1.	HPS 5	As per Serial 2.
5	Application Prone Supported	200	5	a. 1 x 1.3 m target screen with Figure 11 target superimposed. b. Scoring circles superimposed (1) 750 mm circle. (2) 1.3 m circle.	HPS 20	a. No time limit. b. All shots signalled.
6	Rapid Prone Supported	200	5	As per Serial 5.	HPS 20	a. Firers in prone supported position. b. Order WATCH & SHOOT. c. Target exposed for 20 seconds. 5 shots to be fired. d. No signalling of shots.

C7 and C8

ALL ARMS AND SERVICES

ALTERNATIVE PERSONAL WEAPON ASSESSMENT

SER	PRACTICE	RANGE	RDS	TARGET	SCORE	REMARKS
7	Snap Prone Supported	200	5	a. Figure 11 target hand held. b. Five exposures of 5 seconds with 5-10 seconds interval between exposures.	HPS 5	a. Firers adopt prone supported position. b. Order WATCH & SHOOT. c. Fire one round at each exposure. d. Targets fall when hit.
<p>NOTES</p> <p>1. Scoring:</p> <p>a. Serials 2, 3 and 4 points are awarded for ability to group within the standard at Annex A.</p> <p>b. Serials 5 and 6:</p> <p>(1) Hits on the Figure 11 target within the 750 mm circle - 4 points. (2) Hits of the Figure 11 target within the 750 mm circle - 2 points. (3) Hits within the 1.3 m circle - 1 point.</p> <p>c. Serial 7 - one point per hit. d. HPS - 60 points. e. Pass - 30 points.</p>						

CHAPTER 7

DESTRUCTION AND REFERENCES

701. METHODS OF DESTRUCTION

Annex A contains the recommended methods of destruction.

702. REFERENCES AND STANDARDIZATION AGREEMENTS

Annex B contains a list of related publications and standardization agreements.

(703 to 799 inclusive: Not allocated)

METHODS OF DESTRUCTION

PRIORITY OF DESTRUCTION

1. The following priorities should be followed when destroying the rifle:
 - a. breech mechanism;
 - b. barrel and
 - c. sights.

GUIDELINES GOVERNING DESTRUCTION

2. The following guidelines should be observed when destroying rifles:
 - a. the destruction must be as complete as circumstances will permit;
 - b. if there is insufficient time for complete destruction the parts essential to the operation of the weapon will be destroyed, beginning with those parts listed in order of priority in paragraph one; and
 - c. the same essential parts of each weapon must be destroyed to prevent the reconstruction of a complete weapon from several damaged ones.

DESTRUCTION PRIMARY METHOD

3. The primary method of destruction is:
 - a. break or dispose of the firing pin;
 - b. break or dispose of the extractor;
 - c. bend the barrel;
 - d. destroy sights;

ALTERNATE METHOD

4. Bend the barrel.

DISPOSAL

5. To ensure proper disposal the broken weapon and parts should be buried or dumped into streams, mud, snow, sumps or latrines.