

REPORT ON THE M-16
RIFLE PROGRAM

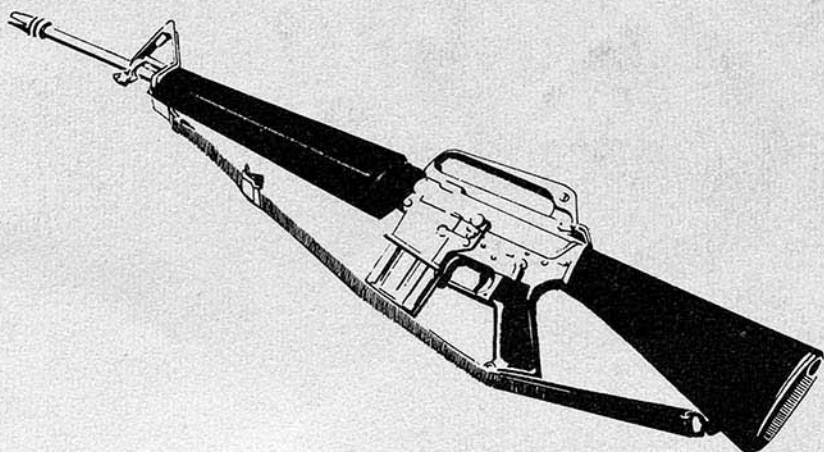

DEUTSCHLAND ORDNANCE CO.

P. O. BOX 801

SANTA CLARA, CALIFORNIA, U. S. A. 95052

Digitized by:

MARS TM-160

15 JANUARY 1968

REPORT ON THE M-16
RIFLE PROGRAM

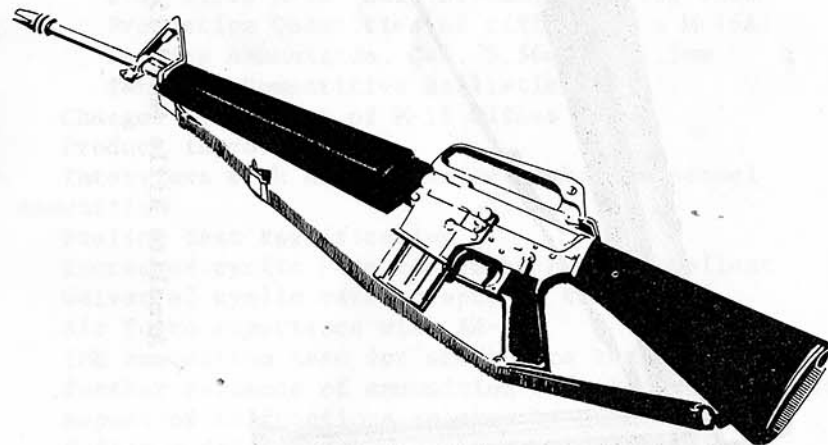

DEUTSCHLAND ORDNANCE CO.

P. O. BOX 801

SANTA CLARA, CALIFORNIA, U. S. A. 95052



ArmaLite Rifle Model 15, Caliber .223

	Page
Background of M-16 rifle	1
Historical background on Army rifles	1
Air Force procurement of AR-15 rifle	5
Test of AR-15 rifle in Vietnam by ARPA/OSD	5
Comparison of AR-15 & M-14 rifles by Comptroller, DOD	6
Question of objectivity of Army evaluation	9
Army procurement of AR-15 rifle	11
Fiscal year 1964 procurement	11
Modifications to the rifle	13
Second Army procurement of AR-15 rifle	19
Army small arms weapons system program (SAWS)	15
Sole source procurement of AR-15 rifle	17
Acquisition of rights and data	19
Excessive profits by Colt's	22
Establishment of a second source of production	22
Mobilization base for M-14 rifles	23
Vietnam investigation	23
Army problems with the M-16	23
Special Section	25
Photographs	25
U.S. Rifle M-16, Cal. 5.56mm, Interior View	29
Production Quantities of rifle M-16 & M-16A1	30
Service Ammunition, Cal. 5.56mm x 44.5mm	31
Table of Comparative Ballistics	32
Changes in support of M-16 rifles	33
Product improvement	33
Interviews with Army & Marine combat personnel	35
Ammunition	38
Fouling test specification	41
Increased cyclic rate caused by ball propellant	42
Waiver of cyclic rate acceptance test	42
Air Force experience with AR-15	43
IMR ammunition used for acceptance test	43
Further evidence of ammunition effect on cyclic rate	44
Report of malfunctions related to ammunition	45
Buffer modification	46
Ammunition deficiencies called to attention of DOD	46
Quality assurance program	48
Lubricants	50
M-16 training publications	51
Foreign sales	51
Possible conflict of interest	52
Royalties	54
Actions taken subsequent to subcommittee's inquiry	55
Findings and recommendations	56

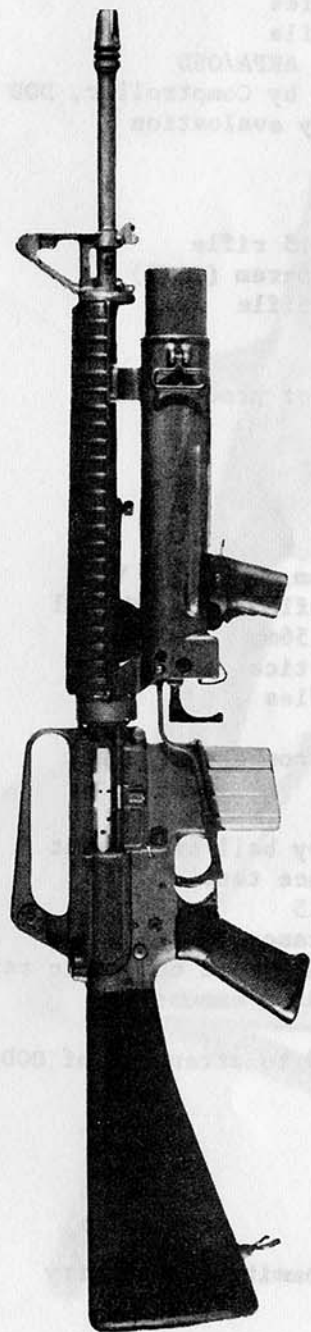

U.S. Rifle M16 with Grenade Launcher M148

REPORT OF THE SPECIAL SUBCOMMITTEE ON THE M-16 RIFLE PROGRAM

By letter dated May 3, 1967, a special subcommittee on the M-16 rifle was established by the Honorable L. Mendel Rivers, chairman of the House Committee on Armed Services. Members appointed to the subcommittee were: Mr. Richard Ichord, of Missouri, chairman; Mr. Speedy O. Long, of Louisiana; and Mr. William G. Bray, of Indiana. The subcommittee was directed to make inquiry into the development, history, distribution, sale, and adequacy of the present M-16 rifle. Also, the subcommittee was directed to determine the advisability of relying on a sole source for production of the rifle and any military proposals for a followon weapon.

Extensive hearings were conducted by the subcommittee between May 15 and August 22, 1967. Many contacts or inquiries were received by members of the subcommittee. In addition, field investigations were conducted at Fort Benning, Ga.; Camp Pendleton and Hamilton Air Force Base, Calif.; several military hospitals; and throughout South Vietnam. Also, visits were made to the producer's plant at Hartford, Conn., and to the facilities of two former M-14 rifle producers, Olin-Mathieson and Harrington & Richardson. An interim report was submitted to the chairman of the Armed Services Committee on June 30, 1967, shortly after the subcommittee returned from Vietnam.

BACKGROUND

The M-16 rifle was designed in 1957 by Mr. Eugene M. Stoner, chief engineer of Armalite, a division of Fairchild Engine and Airplane Corp. The M-16, originally known as the AR-15 was subsequently identified as the XM16E1 and the M-16A. Regardless of designation, all models are almost identical. The major difference is a manual assist bolt closure device added to the Army and Marine version first known as the XM16E1 and classified "standard" by the Army in February 1967 as the M-16A1. The original AR-15 adopted by the Air Force is now known as the M-16 rifle. The rifle is a 5.56-millimeter, magazine-fed, gas-operated, air-cooled, shoulder weapon. It is a lightweight, high-velocity system designed to fire a .223-caliber cartridge.

HISTORICAL BACKGROUND ON ARMY RIFLES

The following historical background of the Army rifle program is based on an Army study, dated January 9, 1963,¹ and other information contained in the subcommittee files or the hearing record:

¹ "Rifle Evaluation," a study made under monitorship, Office, Deputy Chief of Staff for Military Operations, Headquarters, Department of the Army.

Since the introduction of the .30 caliber small arms round in 1903, the U.S. Army has consistently required that the rifle and automatic small arms (BAR and machine guns) fire the same cartridge. The .30 caliber cartridge was considered the optimum size for general purpose use for these reasons:

(1) The bullet was large enough to facilitate development of special purpose rounds, i.e., ball, tracer, incendiary, and armor piercing.

(2) The round was the most powerful that could be tolerated in a shoulder weapon and still adequately meet the extended range performance required in the automatic weapon.

Satisfactory performance of the .30 caliber family of weapons in World War I led to its general acceptance as a reliable and efficient system. The Ballistics Research Laboratory, Aberdeen, Maryland, as early as 1928 recommended investigation of a small caliber, high-velocity system (caliber .276 and .25 and smaller) because of the promised savings in weight and possible increase in lethality. However, the Army, at that time, preferred to increase the effectiveness of the infantry soldier by developing a semi-automatic rifle for the proven .30 caliber cartridge and maintain the desirable feature of ammunition interchangeability with the automatic weapons already in the Army inventory.

The semi-automatic M-1 (Garand) rifle was the outgrowth of this development and served very effectively during World War II and Korea. However, in 1945 the Army recognized that the M-1 rifle was heavier than desired and began to investigate systems which would be lighter and capable of full automatic fire. By again specifying the use of the full size, .30 caliber cartridge, the possibility of designing a truly lightweight weapon was severely handicapped. Several models were built, but none was adopted.

In 1954 the adoption of the NATO 7.62mm round required reorientation of the U.S. rifle program to accommodate the shorter length of the NATO round. The T44E4 was specifically designed for the NATO round but incorporated the best features of the developmental weapons preceding it. In June 1957, the T44E4 was classified standard as the M-14 rifle although it was recognized that it provided only a minor technical improvement over the M-1.² The primary advantages of its adoption were its ability to replace the M-1, the BAR and the carbine while simultaneously fulfilling the NATO agreement with respect to standardization of small arms ammunition.

(The subcommittee notes that the Army requirements development plan 1969-72 provides the following guidance to the Army staff on the development of new material: "Marginal improvements in existing weapons and equipment are not desired. As a general order of magnitude, an improvement of less than 25 percent is considered marginal. R. & D. projects which do not promise an improvement of at least 25 percent should either be reoriented or terminated.")

In 1958 the AR-15 caliber .223 rifle was first tested by the Army at Aberdeen Proving Ground, Fort Benning, Ga., and Fort Greely, Alaska. Although the concept and the rifle reportedly were well received by CONARC, there were reservations as to the suitability of the caliber .223 round as a military cartridge.

The advantages and disadvantages of the AR-15 system led to divergent positions within the Army as to its suitability. A board of general officers, headed by a General Powell, was convened late in 1958 to review the entire rifle program and, if possible, reconcile the conflicting opinions. The Powell Board liked the small-caliber high-velocity concept but allegedly recommended no further consideration be given to the caliber .223 round. They further recommended "that the M-14 be retained for the automatic rifle role but that development of an AR-15-type weapon chambered for a caliber .258 round be expedited to replace the M-14 in the rifle role."³ The caliber .258 reportedly was the Powell Board's estimate of the optimum small-caliber round.

² Emphasis added.

³ "Rifle Evaluation," a study made under monitorship, Office, Deputy Chief of Staff for Military Operations, Headquarters, Department of the Army.

In late 1958, Headquarters, Continental Army Command (CONARC) directed the Army Combat Development Experimentation Center, Fort Ord, Calif., to conduct a lightweight, high-velocity rifle experiment. The stated purpose of the experiment was "(a) to compare the relative effectiveness of variously organized rifle squads armed with M-14 rifles; and (b) to determine the impact of the lightweight, high-velocity rifles on squad organization, techniques, and logistics."

The report states that the experiment "was an exhaustive comparison of target hit performance, in simulated attack and defense situations, of squads armed with the U.S. rifle M-14, caliber .30 (7.62mm-NATO); the Armalite AR-15 rifle, caliber .222; and the Winchester lightweight military rifle, caliber .224." The experiment was conducted by the U.S. Army Combat Development Experimentation Center during the period December 1, 1958-March 22, 1959.

The final report, dated May 30, 1959, contained the following conclusions:

a. With a total combat weight per man equivalent to that planned for riflemen armed with the M-14, a squad consisting of from 5 to 7 men armed with the LWHVR system would have better hit distribution and greater hit capability than the present eleven-man M-14 squad. Furthermore, employment of the smaller squad armed with the lightweight rifle system would permit more economical use of manpower on the battlefield.

b. By opinion poll, the experimentation troops favor the LWHVR system, as represented by the Armalite, because of its demonstrated characteristics of lightness in weight, reliability, balance and grip, and freedom from recoil and climb on full automatic (ease of firing).

c. The Winchester rifle is comparable to the M-14 in hit probability.

d. The Armalite rifle is comparable to the M-14 in reliability.

e. Both candidate weapons of the lightweight high-velocity rifle system are superior to the M-14 in hit distribution.

f. The presently developed representatives of the lightweight high-velocity rifle system require the following improvements before further experimentation with them should be considered:

(1) Winchester Lightweight Military Rifle, caliber .224, must be redesigned so that the component parts, including the bolt assembly, are strengthened and made more resistant to breakage, to bring the functional reliability equal to or above that of the M-14.

(2) Armalite, AR-15, caliber .222, must be modified and improved, with special emphasis on the sights, to bring the hit capability equal to or above that of the M-14.

g. Automatic fire with an LWHV rifle appears to have exceptional tactical value when the rifle is fired in short bursts (three to six rounds) on full automatic.

h. The attributes demonstrated by the prototype weapons of the lightweight high-velocity category indicate an overall combat potential superior to that of the M-14. Such advantages include: inherent characteristics of lightness in weight of arms and ammunition, ease of handling, superior full automatic firing capability, accuracy of the Winchester, and functional reliability of the Armalite.

The report recommended:

a. That emphasis be placed on the development of a lightweight high-velocity rifle combining the accuracy characteristics of the Winchester with the reliability characteristics of the Armalite, and not exceeding the weapon/ammunition weight of either.

b. That such a lightweight high-velocity rifle be developed with a view toward early replacement of current rifles.

c. That concurrent with the adoption of a lightweight high-velocity rifle, serious consideration be given to reduction in the size of the present squad with resultant great saving in manpower.

In January 1959, before the above rifle experiment was completed, the Army Chief of Staff, allegedly after analysis of all available facts

including the recommendations of the earlier mentioned Powell Board, decided that the M-14 production would remain as scheduled; that the 7.62-millimeter round would be continued unless a new concept offered a very significant improvement; and that any product improvement would be kept in the 7.62-millimeter caliber.

As a result of this decision, the Army abandoned attempts to develop a conventional small caliber high-velocity system and concentrated its efforts on an unconventional system which allegedly promised significant advantages in combat effectiveness. This effort led to the special-purpose individual weapon (SPIW) program which it is claimed will produce a significantly improved weapons system in the future.

The SPIW concept is intended to combine and improve the point target capability as represented by the M-14 rifle and the area target capability as represented by the M-79 grenade launcher in one weapon. By firing multiple projectiles simultaneously, or almost simultaneously, in an optimum dispersion pattern, the hit probability or the point target component on man-sized targets is predicted to be at least double that of conventional rifle systems. The area target component will be at least as good as the M-79 grenade launcher.

The Army anticipated the availability of the SPIW for late fiscal year 1965. However, the weapon encountered development problems and still remains a research and development system not expected to be completed for several more years, if then.

The Air Force continued to test and evaluate the AR-15 rifle with very favorable results and on May 22, 1961, validated the quantitative requirement to procure the AR-15 rifle and ammunition. In January 1962 the AR-15 was classified as a "standard" weapon for the Air Force inventory.

The Air Force was advised by Colt that the .223 caliber 55 grain, metal-jacketed bullet manufactured by Remington Arms, Inc., was developed in cooperation with Armalite for use in the AR-15 rifle. The Remington cartridge was given a status classification of "development" on December 19, 1961. A test was conducted at Hill Air Force Base, Utah, on February 20, 1962, to determine if the Remington round was of sufficient quality to justify complete testing and development for USAF use. The conclusions of the test were:

Based on the results of this test conducted at OOMA (Ogden Air Materiel Area) and the requirements for the New Basic Weapon as outlined by USAF, the Cartridge, Caliber .223 manufactured by Remington Arms Inc. and used in this test appears to have the qualities desired in this weapon system.

Killing and wounding power of the cartridge is excellent at ranges of at least 500 yards. The cartridges weigh approximately one-half as much as a .30-06 cartridge.

The bullet, having a high velocity, travels a flatter trajectory than slower bullets, giving less vertical error with a fixed iron sight.

It was recommended that a large sample of the ammunition tested be acquired to complete the testing required before adopting the round as a U.S. Air Force item. The Remington specifications on this ammunition called for single base powder suitable to ballistic requirements of this cartridge with maximum average pressure of 52,000 pounds per square inch and an average velocity of 3,245 plus or minus 40 feet per second.

On May 23, 1962, the Air Force awarded a contract to Colt Patent Firearms Manufacturing Co. (Colt's Inc.) for 8,500 rifles, spare parts, and 8,500,000 rounds of ammunition. Colt subcontracted manufacture of the ammunition to Remington Arms Co., Inc., with inspection and acceptance of ammunition to be based on independent laboratory certification that ammunition conforms to established commercial standards. The Remington specification was the same as that tested 3 months earlier by the Air Force at Hill Air Force Base, Utah.

The Air Force change of ammunition from the single base extruded powder to the double base ball powder occurred on the subsequent procurement of ammunition in October 1963. This will be discussed in a separate section of the report under "Ammunition."

TEST OF AR-15 RIFLE IN VIETNAM BY ARPA/OSD

The problem of selecting the most suitable basic weapon for the Vietnamese soldier is complicated by his small stature and light weight. The average soldier stands 5 feet tall and weighs 90 pounds. In 1961 the principal U.S. weapons issued to Vietnamese troops included the U.S. rifle, caliber .30 M-1; Browning automatic rifle (BAR), caliber .30; the Thompson submachinegun, caliber .45; and the U.S. carbine, caliber .30, M-1.

Reportedly because of its availability and the results of extensive studies and previous testing by military agencies, the Colt Armalite AR-15 rifle was selected in July 1961 as the most suitable weapon for initial tests to determine if it was compatible with the small stature, body configuration and light weight of the Vietnamese soldier and to evaluate the weapon under actual combat condition in South Vietnam.

Based upon favorable observations of the AR-15 by both U.S. advisers and Republic of Vietnam Armed Forces (RVNAF) commanders following limited firing demonstrations conducted in Vietnam during August 1961, weapons were requested in numbers sufficient to conduct a full-scale combat evaluation of the AR-15 by selected units of the RVNAF. In December 1961, the Secretary of Defense approved the procurement of 1,000 AR-15 rifles, necessary ammunition, spare parts and accessories for evaluation.

The Advanced Research Projects Agency of the Office of the Secretary of Defense negotiated a contract with the firm of Cooper-Macdonald, Inc., Baltimore, Md., for procurement and air shipment of all material. The first shipment was received on January 27, 1962. Operational evaluation and testing began on February 1 and terminated on July 15, 1962. It is reported that the ammunition used was produced by Remington under normal commercial specifications.

To accomplish the stated purpose of this test, it was divided into two parts. One part was a combat evaluation of the AR-15 in which the weapons were issued to specially selected ARVN units for use in their operations against the Vietcong. The other part of the test consisted of a comparison between the AR-15 rifle and the M-2 carbine. The test report contains the following:

RESULTS, COMBAT EVALUATION

Summary.—The Vietnamese Unit Commanders and U.S. Advisors who participated in the evaluation consider the AR-15 Rifle to be a more desirable weapon

for use in Vietnam than the M-1 Rifle, BAR, Thompson Sub-machine, and M-1 Carbine for the following reasons:

(a) It is easier to train the Vietnamese troops to use the AR-15 than the M-1 Rifle, BAR, M-1 Carbine, or the submachine gun.

(b) The AR-15's physical characteristics are well-suited to the small stature of the Vietnamese soldier.

(c) It is easier to maintain the AR-15 both in the field and in garrison than the M-1 Rifle, BAR, Sub-machine gun, or the M-1 Carbine.

(d) The ruggedness and durability of the AR-15 are comparable to that of the M-1 Rifle and superior to that of the BAR, Sub-machine gun, and M-1 Carbine.

(e) The AR-15 imposes less logistical burden than any of the four principal weapons presently being used by Vietnamese Forces.

(f) The AR-15 is tactically more versatile than any present weapon being used by Vietnamese Forces.

(g) In Semi-automatic fire, the accuracy of the AR-15 is considered comparable to that of the M-1 Rifle, and superior to that of the M-1 Carbine.

(h) In automatic fire, the accuracy of the AR-15 is considered comparable to the Browning Automatic Rifle and superior to the Sub-machine Gun.

The report states that the lethality of the AR-15 and its reliability record were particularly impressive. No parts breakage was encountered while firing approximately 80,000 rounds during the comparison test. Only two parts were issued to replace breakage for the entire 1,000 weapons tested.

The report further stated that no deficiencies in the weapon requiring correction prior to adoption were found during the test in Vietnam, although two minor changes are recommended for product improvement. These were: (1) Roughen the surface of the upper hand guard to make it easier to grip when hands are sweaty; and (2) add an additional section and provide a T-shaped handle to the cleaning rod.

As a result of the ARPA test, the commander of the U.S. Military Advisory Command in Vietnam (COMUSMACV), General Harkins, on October 19, 1962, requested a substantial quantity of AR-15 rifles and ammunition to equip certain South Vietnamese Army units. This request was supported by the Department of the Army but opposed by the commander in chief, Pacific Forces (CINCPAC), even though he recognized the AR-15 as an excellent weapon. CINCPAC's objection was based on the cost of introducing this weapon into the military assistance program and the requirement for other projects with higher priority which were bidding for limited funds.

On March 14, 1963, the Joint Chiefs of Staff concurred in the CINCPAC position stating that the AR-15 rifle should not be programmed under the military assistance program for Southeast Asia because of increased cost, logistic complications, the inferior nature of enemy weapons and worldwide MAP implications. On March 25, 1963, the Secretary of Defense approved the JCS recommendation.

COMPARISON OF AR-15 AND M-14 RIFLES BY COMPTROLLER, DEPARTMENT OF DEFENSE

On September 27, 1962, a report was submitted to the Secretary of Defense by the Office of the Comptroller, Department of Defense. This report was stated to be a cost-effectiveness comparison of the M-14 rifle then being procured by the U.S. Army, with the AR-15 then being procured by the U.S. Air Force.

The comparison was relative to general combat use of the AR-15 by Army units in both normal and special combat situations. The study concluded that the AR-15 was decidedly superior in many of the factors considered and in none of them was the M-14 superior. It further concluded that in combat the AR-15 was the superior weapon. Other conclusions contained in the report were:

1. The study concluded that "taking into account the greater lethality of the AR-15 rifle and improvements in accuracy and rate of fire in this weapon since 1959, in overall squad kill potential the AR-15 rifle is up to 5 times as effective as the M-14 rifle."

2. In automatic fire capability and tactical flexibility the AR-15 rifle is markedly superior to the M-14 rifle.

3. The AR-15 rifle can replace, with gains in each case, all standard shoulder-fired weapons.

4. The M-14 rifle is marginal, at best, as a replacement for the BAR, is somewhat less satisfactory as a semi-automatic rifle than the M-1 rifle, and is not capable of replacing the sub-machine gun or the M-79 grenade launcher.

5. The AR-15 rifle can be produced with less difficulty, to a higher quality, and at a lower cost than the M-14 rifle.

6. In reliability, durability, ruggedness, performance under adverse conditions, and ease of maintenance the AR-15 is a significant improvement over any of the standard weapons including the M-14 rifle. The M-14 rifle is weak in the sum of these characteristics. Earlier reports that the AR-15 rifle is deficient in performance under Arctic conditions or with rain in the barrel are incorrect.

7. In lethality the AR-15 rifle bullet is markedly superior to that of the M-14 rifle or any other known bullet.

8. It is significantly easier to train the soldier with the AR-15 than with the M-14 rifle.

9. Three times as much ammunition can be carried on the individual soldier within the standard weapon-and-ammunition load, or alternately the soldier's combat load can be reduced by 40%, with the AR-15 rifle as compared with the M-14.

10. In accuracy, at all ranges of U.S. Army interest for rifles, the AR-15 rifle is at least as effective as the M-14 rifle, and the AR-15 rifle ammunition has further growth potential in this respect.

11. In meeting the U.S. Army penetration requirement the M-14 and AR-15 rifles are essentially equal.

12. In the ability of the bullet to penetrate brush the AR-15 and M-14 rifles are approximately equal and both are adequate.

The subcommittee notes that the ARPA test and the evaluation of the AR-15 rifle by the Defense Comptroller were based on the performance of the rifle using a single-base extruded powder (IMR).

After receiving the report from the office of his Comptroller, the Secretary of Defense directed a memorandum on October 12, 1962, to the Secretary of the Army stating that he had seen certain evidence which appeared to indicate that the M-14 was definitely inferior in firepower and combat effectiveness to the assault rifle of the Soviets and their satellite forces worldwide. Also, that the AR-15 was markedly superior to the M-14 rifle in every respect of importance to military operations. The Secretary of Defense requested the view of the Department of the Army on the relative effectiveness of the M-14, the AR-15, and the Soviet rifle (AK-47).

In response to Secretary McNamara's memorandum, the Secretary of the Army directed an "impartial and objective evaluation of the relative effectiveness of the three weapons to include appropriate comparison tests." These tests and evaluations were conducted on an Army-wide basis, with the exception of the Pacific Command. The Combat Developments Command conducted the tactical evaluation and troop testing. The Army Materiel Command conducted technical

evaluation and testing of the rifles. The report was submitted on January 9, 1963.⁴ It indicated that "throughout the numerous reports available on this subject it is apparent that opinions and positions are many and varied as are their origins. It appears that the divergencies encountered are due to the extreme personal nature of a hand-held weapon. Personal likes and dislikes on intimate or personal implications are comparable to the variance in preference for rifles."⁵

The report stated that the study was "based on recently compiled inputs that stressed impartiality and objectivity and on past evaluations that are deemed to have been objective."

The Army evaluation went far beyond the request of the Secretary of Defense. It considered the weapons and ammunition; logistical implications; doctrine and concepts; political implications (international and domestic); Soviet small-arms characteristics, doctrine, concept of development trends; technical aspects of the three weapons and the special-purpose individual weapon (SPIW) and the impact on standardization.

The Army evaluation concluded:

An analysis of all data submitted indicated that, of the weapons tested, only the M-14 is acceptable for general use in the U.S. Army. The AR-15, although lighter than the M-14, is not considered suitable as a replacement weapon because: it is less reliable; it has poor pointing and night firing characteristics; its penetration is marginally satisfactory; and its adoption would violate the NATO standardization agreements.

The Army study recommended "that the M-14 be retained as the standard U.S. Army rifle until the SPIW can be developed on an expedited basis." At this point in time the target date for initial procurement of the SPIW, under an accelerated research and development program, was January 1, 1965.

The Army rifle evaluation considered three courses of action as alternatives to the then existing program. Course of action A would continue M-14 rifle production until a radically improved individual weapon could be procured, such as the SPIW or its equal. Course of action B was to terminate production of the M-14 rifle at the end of the fiscal year 1963 procurement, to procure a military version of the AR-15 to complete the inventory objective as rapidly as possible, and to reorient the research and development small arms program to provide a weapon meeting or surpassing SPIW characteristics in a future time frame. Course of action C was to continue procurement of the M-14 rifle and procure, in fiscal year 1964, the military version of the AR-15 to equip in priority, air assault units, airborne units and Special Forces, and to continue with SPIW under normal research and development program with procurement commencing in fiscal year 1967.

Course of Action A was recommended in the Army evaluation report submitted January 9, 1963. The commanding general, U.S. Army Combat Development Command (the command responsible for summarizing the results of troop tests in Alaska, the Canal Zone, West Germany, Fort Carson, Colo., and Fort Hood, Tex.) recommended continued use of the M-14 by the U.S. Army force in Europe and equipping all units earmarked for deployment to Europe with the M-14 except airborne

⁴ "Rifle Evaluation," a comparative evaluation of U.S. Army rifle 7.62 millimeter, M-14; ArmaLite rifle caliber .223, AR-15; Soviet assault rifle AK-47.

⁵ The committee takes note also of the "NIH" (not invented here) attitude.

and Special Forces units. He further recommended equipping all air assault, airborne, and Special Forces units with the AR-15 "after the deficiencies in reliability and night-firing capabilities are corrected."

The Army Materiel Command (the command responsible for summarizing the results of tests conducted by the Army Infantry Board (Fort Benning, Ga.), Arctic Test Board (Fort Greely, Alaska), Ballistics Research Laboratory and Development and Proof Services at Aberdeen Proving Grounds, Md.) concluded, "based on assumption that the two major deficiencies of firing in the rain and in cold dense air are shown to be acceptable, easily correctible, or nonexistent, that the AR-15 rifle would be preferable to the M-14 for worldwide use under the assumption that this would be the initial introduction of a weapon into an army." This conclusion was said to be based primarily on the fact that the AR-15 offers a substantial weight reduction without sacrifice of essential performance characteristics.

The Army Materiel Command recommended that the AR-15 not be adopted as an across-the-board replacement for the M-14. It recommended "that the AR-15 be procured for Special Forces units and airborne forces to exploit the weight advantage and gain experience with the system, if tests in progress prove it to be acceptable." Continued development of the SPIW program on an expedited basis to insure earliest possible availability was also recommended.

Question of objectivity of Army evaluation

Apparently there was reason to question the objectivity of the Army-wide test and evaluation of the weapons considered. In December 1962 the Secretary of the Army directed that the Department of the Army Inspector General investigate the circumstances surrounding the November-December 1962 evaluation and tests to ascertain their validity.

The purpose of the Inspector General investigation was set forth in a directive from the Secretary of the Army dated December 21, 1962,⁶ which stated:

In October 1962, I directed that there be conducted an impartial and objective evaluation of the relative effectiveness of the M-14, the AR-15, and the Soviet assault rifle to include appropriate comparison tests.

As a matter of the highest priority I desire you to conduct a thorough investigation into all of the circumstances surrounding the conduct and evaluation of such tests, including, but not limited to—

- a. Instructions (formal, informal, official, or unofficial) which may have been issued with respect to such tests at any echelon within the Department of the Army;
- b. The conditions under which such tests have been or are being carried out;
- c. The conduct of the tests themselves;
- d. The methods by which the results of such tests are recorded;
- e. The methods by which such tests are evaluated; and
- f. The attitude towards such tests by any personnel in any way connected with their conduct or evaluation.

The purpose of your investigation will be to ascertain whether there is any ground upon which the thoroughness, accuracy or objectivity of such tests, or of the conclusions based on such tests, can be questioned.

The investigation revealed that (not verbatim)—

a. An informal planning conference concerned with conduct of a comparative evaluation of the AR-15 and the M-14 rifles was held in Headquarters, U.S.

⁶ "Summary of Facts Pertaining to Investigation Concerning Comparative Evaluation of AR-15, M-14, and AK-47 Rifles" submitted by the Department of the Army, Sept. 15, 1967.

Army Materiel Command on 22 October 1962, with representatives from the following agencies: Headquarters, U.S. Army Materiel Command; Ballistic Research Laboratories, Aberdeen Proving Ground; Headquarters, U.S. Army Test and Evaluation Command; Development and Proof Services, Aberdeen Proving Ground; and the U.S. Army Infantry Board. The point was made during the discussion of the tests to be conducted and the agencies responsible for their conduct that those phases of previous tests which had reflected adversely on the AR-15 would be retested.⁷ The representative of the U.S. Army Infantry Board, in his memorandum for the record of the meeting, included the statement, "The U.S. Army Infantry Board will conduct only those tests that will reflect adversely on the AR-15 rifle plus other tests that may be considered appropriate * * *." Other written records of the meeting did not confirm the implication contained in the statement. All persons attending the meeting were interrogated and denied under oath that the implication conveyed by the statement was expressed at the meeting. The Army Colonel responsible explained that the statement from his memorandum for record was not a reflection of what he intended to say and could only have resulted through administrative error.

b. After test plans had been approved and tests were under way at Development and Proof Services (D&PS), Aberdeen Proving Ground, an officer from the Office of the Chief of Research and Development telephoned USATEC and suggested that the AR-15 be subjected to a specific form of rain test * * *. The AR-15 was subjected to the test, failed it, and this fact was noted in the D&PS test report. The M-14 was not subjected concurrently to this same test * * *.

c. During the conduct of the lethality tests at the Ballistics Research Laboratory, the M-14 rifle being tested gave indications of being inaccurate. The test weapon was replaced by another model of the M-14 for the continuance of the test.

d. M-14 rifles provided for the conduct of the test at Aberdeen Proving Ground were specially selected and showed closer than normal tolerances * * *.

e. M-14 ammunition used for the initial stages of the lethality tests at BRL (Aberdeen) was more accurate than an average lot of M-14 ammunition. (The handpicked ammunition was apparently "matchgrade").⁸

f. Personnel selected for firing the AR-15 were less familiar with their weapon than those firing the M-14, thus providing a handicap to the personnel with the AR-15.

g. The wooden stock and forearm of the M-14's subjected to the rain test at Aberdeen became swollen and discolored, a fact which was not recorded in the test results.

h. A separate summary report, which forwarded an evaluation of the test reports of subordinate agencies, indicated that wording used in interpreting tests did not appear to be as favorable to the AR-15 as test results indicated.

i. The analysis, conclusions, and recommendations of the Army Infantry Board test report indicated bias or prejudice against the AR-15 and in favor of the M-14.

j. The test report of the Arctic Test Board indicated some irregularities.

The report of investigation submitted by the Inspector General concluded that—

a. Instructions governing the tests, conditions under which the tests were run, conduct of the tests themselves and the methods of recording the test data were fair, impartial, objective and nonprejudicial.

b. Methods of evaluating the test data, as pertains to analytical processes involved and treatment of certain test results at the U.S. Army Infantry School (USAIS) and the U.S. Army Infantry Board (USAIB), were subjective and tended to favor the M-14 (USAIB).

c. Reporting of the test results, as pertains to presentation of the data, mixing personal observations with the analysis and the tone of the verbiage of the report at USAIS and USAIB, was subjective and tended to favor the M-14.

d. Attitudes of certain personnel at USAIS and USAIB were favorable to the M-14 to a degree that these attitudes may have caused subjective treatment of tests results in analysis and reporting.

⁷ Emphasis added.

⁸ Committee observation.

Shortly after completion of the evaluation of the Inspector General's investigation and the Army-wide test and evaluation of the M-14 versus the AR-15 and the AK-47, the decision was made to procure 85,000 AR-15 rifles to equip Airborne, Assault, and Special Forces units. Since the Air Force was also procuring the AR-15 at this time, the Secretary of Defense designated the Army as the Defense agent for all users of the rifle and ammunition. The Air Force contract negotiations for its fiscal year 1963 buy were at an advanced stage, so they were allowed to continue. However, beginning with the fiscal year 1964 buy, the Army was designated as the procuring agency for all services.

In a memorandum to the three service Secretaries, dated March 11, 1963, Secretary McNamara instructed: "so that beginning with the fiscal year 1964 procurement only one rifle, rather than separate service versions, is produced and that it is produced with minimum delay, modifications of the weapon and its ammunition are to be concurred in by all four services. Only such modifications as are absolutely necessary should be made."

In an effort to insure this objective, a Technical Coordinating Committee was established with representation from each military service. A desire was stated to formalize AR-15 rifle technical matters at technical committee meetings to be held probably on a monthly basis or more frequently, if required. The AR-15 rifle project manager was designated as Chairman of the Committee.

Fiscal year 1964 procurement

On April 5, 1963, the Secretary of the Army submitted a memorandum to the Secretary of Defense outlining the Army's plans for standardization and procurement of the AR-15 rifle and ammunition. The Army stated the plan was based "on the assumption that requirements for the weapon will be approximately 104,000 in fiscal year 1964 (85,000 Army; 19,000 Air Force) and that subsequent fiscal year's requirements will primarily be limited to 33,500 rifles in fiscal year 1965 for the Air Force. The fiscal year 1965 procurement will complete the total known Air Force requirements of 80,000." The Army memorandum stated that General Harkins' (COMUSMACV) request for 20,000 AR-15 rifles for Vietnamese units was not considered in view of the unfavorable decision of the Joint Chiefs of Staff.

The Army memorandum of April 5, 1963, stated that consideration was given to the comparative costs of sole source versus competitive procurement in developing the procurement plan. The comparison indicated that sole-source procurement was expected to result in the lowest cost, earlier production, with fewer administrative, legal, and employment problems.

It was estimated that production of the 104,000 rifles under the sole-source procurement plan could be accomplished within 29 months after initiation of the program whereas competitive procurement would require 33 months to complete deliveries. The unit cost of the rifle under the sole-source program was expected to be \$125.44 compared to a competitive procurement cost of \$138.74.

The memorandum also included changes to the then current AR-15 rifle which were considered absolutely essential. Agreement of all

services on these changes was expected provided it would not result in excessive increase in cost, degradation of performance, or delay in production. The modifications or changes listed were as follows:

- (1) Design a manual bolt closure device,
- (2) Redesign of magazine,
- (3) Modification of the chamber throat to assist extraction of entire cartridge upon clearing weapon.

It was said that these modifications were interrelated and could not be separated.

Other modifications listed and the associated problems were:

- (4) Eliminate slope at the rear right ramp to improve pointing-night-firing characteristics,
- (5) Determine desirable rifle twist to improve stability of round.

The last problem cited was a dimensional incompatibility of ammunition with the rifle chamber. It was proposed to modify the chamber and consider current ammunition configuration as standard. If, after the chamber was modified, the ballistics of the ammunition round were not satisfactory, consideration should be given to modifying the ammunition.

The memorandum also stated that it was planned to procure the .223-caliber ammunition for the AR-15 competitively, soliciting proposals from all commercial sources. Military standards specifications were being developed at this time for the caliber .223 ammunition. These specifications were to assure high-quality ammunition being procured by the services in fiscal year 1963, as well as 1964.

In closing his memorandum the Secretary of the Army stated:

In view of the current limited follow-on requirements for the AR-15 rifle and ammunition, it is considered that an adequate production base will be established. Colt Patent Firearms Company is expected to have established by about 1 July 1963, as a result of the fiscal year 1963 Air Force procurement, a multi-shift capacity of 5,000 rifles per month.

The Army rifle production base plan was reviewed by the Secretary of Defense who, in a memorandum dated June 27, 1963, stated:

My conclusions are that the plan is sound; however, some elements of the Army cost estimates are too high, and the lead times for the rifle and ammunition are unnecessarily long as is the time required for completion of deliveries of the rifle. I also conclude from this review that most of the modifications proposed in the plan are not essential or have already been accomplished.

Secretary McNamara approved the plan with certain provisions and modifications. One of the provisions was as follows:

*To exploit the advantages of this commercial development, the modifications and changes necessary to place the weapons system in development should be accomplished by request to the manufacturer concerned in consultation with the weapons designer.**

According to testimony and other information received by the subcommittee, this provision calling for consultation with the weapon designer on modifications and changes was not followed by the Army or whenever the designer was consulted it was after the fact and the decisions had been made and actions already taken. For example, the subcommittee received evidence to the effect that Mr. Frank Vee, a Department of Defense representative on the Technical Coordinating Committee, solicited the weapon designer's opinion about the decision

* Emphasis added.

to authorize WC-846 (ball propellant) for use in 5.56 ammunition. The weapon designer reportedly advised against implementing the decision. The fact of such a conversation was not refuted. Mr. Vee, when queried about the conversation, testified as follows at pages 4668, 4669, 4670, and 4671 of the hearing record.

Mr. VEE. . . . I cannot positively state that I can recall that we discussed the ammunition or the propellants in the ammunition; but I won't say I didn't discuss it. . . .

Mr. ICHORD. 1964 or 1965, along about that time did you have a conversation with him in which you solicited his opinion on the use of the ball propellant in your ammunition?

Mr. VEE. I don't remember that directly, sir. If he had a recorder—if we had a recorder, then I could be positively sure. I am not doubting it; I just can't prove it now.

Mr. ICHORD. . . . Did you not say to him during one of the meetings that the Army wanted to have everything, in ball propellant, that they could, in small arms?

Mr. VEE. Well, I won't deny it. I don't remember.

Mr. ICHORD. . . . So, obviously you talked about two things at that meeting—primer sensitivity, and also the powder. They are two very closely related subjects are they not?

Mr. VEE. Like I say, I am not denying we didn't discuss it. I can't be positive. I know that to be the only time—that the big depth on the private meeting was on sensitivity. That was the important problem.

On November 4, 1963, the Army awarded a letter contract to Colt Patent Firearms Co. (now known as Colt's, Inc.) for 104,000 AR-15 rifles. Of these, 19,000 were for the Air Force and 85,000 were for the Army.

Modifications to the rifle

Prior to the award of the first production contract by the Army, two major modifications were made to the rifle. The first and most expensive was the addition of the manual assist bolt-closure device. This modification was made at the insistence of the Army and over the objection of the Air Force and Marine Corps. The Air Force position on the manual closing device was as follows:

1. The Air Force does not consider a manual bolt closing device to be an essential part of the AR-15 rifle for the following reasons:

a. The design of this weapon has eliminated all mechanical linkage that was subject to binding during adverse operating conditions. Without the mechanical linkage, the requirement for the manual closing device is eliminated.

b. During more than 3 years of testing and operation of the AR-15 rifle under all types of conditions the Air Force has no record of malfunctions that could have been corrected by use of a manual bolt device.

c. The ARIA tests in South Vietnam did not reveal any requirement for the manual bolt closing device.

d. The recent Marine Corps tests have not indicated any requirement for the manual bolt closing device.

e. The 1958-1960 Army tests of the AR-15 did not reveal a requirement for the manual bolt closing device. The Infantry Board discussed this item during their initial tests, but concluded that there was no justifiable reason for the manual closing device.

f. The Air Force has discussed this matter with the designer of the weapon. The designer reported that he had considered this but did not find it necessary with the free floating bolt.

2. Modification of the AR-15 rifle to incorporate the manual bolt closing feature is considered to be undesirable for several reasons.

a. The modification will probably add weight to the weapon.

b. It will undesirably complicate the mechanism.

c. It will probably add additional parts to the weapon.

d. It will probably increase the cost of the weapon.

e. It will possibly introduce other malfunctions into the operation of the weapon.

f. Designs conceived to date are unproven and may introduce a personnel hazard if the components should malfunction. As designed a malfunction could result in the charging handle being driven to the rear into the face of the shooter.

g. Attempting to incorporate a design change of such magnitude into the weapon will probably delay procurement of the weapon if proper preproduction testing is to be accomplished.

3. During operation of the AR-15 rifle and other hand-held weapons, it has been found that it is not advisable to attempt to manually force the bolt of a weapon closed when a malfunction occurs. Forcing the bolt closed, driving live ammunition into the chamber not only aggravates the malfunction, but is also a dangerous practice. The recommended procedure is to clear the round by pulling the bolt to the rear for recycle. The U.S. Army Training Manuals for both the M-1 and M-14 rifles do not recommend manually forcing the bolt closed during a malfunction but rather specify that the bolt should be pulled to the rear to eject the bad round.

4. In view of the above and the fact that the Air Force will have 27,500 rifles in the inventory without this feature, it is not considered justifiable to include the manual bolt closing feature in the AR-15 rifle.

Both the Navy and the Marine Corps considered the modification to be nonessential. The manufacturer (Colt) took the original position that the manual bolt closure device was not necessary in view of the weapon's reliability. The rifle project manager, Col. Harold W. Yount, admitted in testimony that the modification was not supported by test results but was dictated or directed to be incorporated by "higher authority" in the Department of the Army.

Despite the lack of service agreement and adequate justification, the bolt closure modification was approved by the Secretary of Defense and incorporated into the production rifles to be delivered to the Army. This modification increased the unit cost of the Army rifles by \$4.53 and over the life of the production contracts will cost the taxpayers millions of dollars.

In discussing the bolt closure modification during the subcommittee's hearings the following testimony was received (page 4701 of hearings):

Mr. MORGAN. Was this modification justified on the basis of tests conducted?

Colonel YOUNT. I was unable to justify it on the basis of prior tests.

Mr. ICHORD. You state, Colonel Yount, you weren't able to justify it on the basis of tests. What were you able to justify it on?

Colonel YOUNT. On the basis of direction.

Mr. ICHORD. Where did that direction come from?

Colonel YOUNT. Well, as many decisions which were made on this rifle, this decision emanated from the Department of the Army staff, sir. It was further coordinated with the Department of Defense, and Secretary McNamara personally approved it.

The second major modification changed the barrel twist from a ratio of 1-in-14 to 1-in-12 inches. This change allegedly was made to improve the bullet stability in extremely cold temperatures but it reduced the lethality of the bullet as much as 40 percent according to information provided by witnesses appearing before the subcommittee.¹⁰ The subcommittee notes that the Army now is testing a barrel with a 1-in-14-inch twist again. The subcommittee questions the validity of a re-

¹⁰ Memorandum for the Under Secretary of the Army dated Feb. 10, 1967. Subject "Modifications to the M-16" signed by Wilbur B. Payne, Chief, Office of Operations Research.

quirement for a rifle to meet performance characteristics at minus 65° temperatures that are identical to the performance at a temperature of 125°.

Recently the Army amended the production contract to provide 2,000 rifle barrels containing a 1-in-14-inch twist for further test and evaluation. The subcommittee recommends that this test and evaluation be expedited and conducted in an objective fashion. If it is determined that this barrel twist ratio restores the bullet lethality of the M-16 to that demonstrated in the 1962 ARPA test conducted in Vietnam, an accelerated retrofit program should be initiated immediately.

At the time that Secretary McNamara approved the Army decision to procure the first 85,000 rifles, February 1963, it is reported that he instructed deferral of any further procurement of M-14 rifles. Subsequently, in December 1963 the Army advised the Senate Armed Services Committee that there would be no further procurement of the M-14 rifle. In view of this announced decision by the Army, it is difficult for the subcommittee to understand why little effort was made on the first procurement to obtain reproduction rights and technical data to enable competitive procurement on future requirements.

If the M-14 was not to be procured and the SPIW was not anticipated to be available for several years under the most optimistic expectations, what did the Army propose to procure to meet its operational requirements?

The subject of acquisition of the rights and data package will be discussed in greater detail later in the report.

ARMY SMALL ARMS WEAPONS SYSTEM PROGRAM (SAWS)

In December 1964, the Acting Chief of Staff, U.S. Army, directed a letter to the Commanding General, U.S. Army Combat Developments Command, requesting a comprehensive review and evaluation of small arms weapons systems in being or under development and feasible for adoption within the time frame 1967-80. The study was to determine whether any small arms weapons system or systems provide a degree of superiority over current small arms weapons systems sufficient to warrant acquisition by the U.S. Army and to determine the specific impacts of adoption of individual candidate weapons systems. The commands and agencies having a major area of responsibility in the preparation of supporting study material were:

- (1) U.S. Army Europe, Pacific, Alaska and Southern Commands,
- (2) U.S. Army Continental Army Command,
- (3) U.S. Army Materiel Command,
- (4) Combat Developments Command Experimentation Command, and
- (5) Combined Arms Research Office.

The study submitted on August 30, 1966, was "based upon information gathered and analyses performed primarily by the USACDC, Command Developments Command Infantry Agency under the pro-ponency of the USACDC, Command Developments Command Combat Arms Group."¹¹ The conclusions and recommendations of the

¹¹ U.S. Army Combat Developments Command, Army Small Arms Weapons Systems Study (SAWS).

study submitted were stated to be those of the Commanding General, U.S. Army Combat Developments Command.

The study outlined five alternative courses of action based on the results of the review and evaluation. These ranged from a recommended procurement of no additional rifles or automatic rifles beyond those XM16E1 rifles currently on order until SPIW becomes available to a course of action recommending the procurement of over 1 million XM16E1 rifles as replacement for current M-1 and M-14 rifles.

The SAWS study with its recommendations was reviewed and analyzed by the Army staff and on December 17, 1966, the Secretary of the Army submitted a memorandum to the Secretary of Defense outlining the objectives for the Army rifle program recommended by the Chief of Staff. These were:

- a. Rifle procurement in the foreseeable future should be limited to the XM16E1 rifle.
- b. Steps should be taken to permit early replacement of the caliber .30 rifles (M-1 and BAR) in the Army's inventory with the XM16E1 rifle.
- c. Rifle procurement planning over the long term should be based on the replacement of the M-14 rifle with the XM16E1.
- d. An additional production source for the XM16E1 rifle should be provided in the FY 68 budget.
- e. An active and broadened research and development program should be continued to bring about further major improvements in the Army's small arms."

The memorandum cited actions taken to attain the five objectives outlined and requested approval of the Secretary of Defense.

The Army Secretary's memorandum stated:

Significant findings of our view of the SAWS study include the following:

- a. The XM16E1 rifle is generally superior for Army combat use.
- b. The current SPIW program is unlikely to result in a satisfactory competitive weapon as early as previously forecast.
- c. Based on our experimental results, it is likely that some minor changes in the M-16 system are justified. These include use of a different powder grain in the cartridge and a change in the barrel twist.

By memorandum dated January 14, 1967, the Deputy Secretary of Defense approved for planning purposes objectives *a*, *d*, and *e*; however, approval was withheld on objectives *b* and *c* pending the following additional information:

1. A comprehensive cost/effectiveness evaluation of a one-rifle weapon system versus the present three system family and a mixed M-16/M-14 family which phases out the M-1. The study should explicitly treat the logistic implications of going from a three to a two and then to a one-rifle family, and the marginal benefits and marginal costs of a rifle modernization program which envision replacement of serviceable assets.
2. Your replacement and distribution schedule.
3. NATO implications of your proposed program.
4. Details of proposed changes in the M-16 system with a concurrence of the M-16/XM16E1 Technical Coordinating Committee, to include the effects on the manufacturing process and the availability of production facilities to provide a different powder grain.

Testimony before the subcommittee by Dr. Robert A. Brooks, Assistant Secretary of the Army (p. 4718) indicated that the decision was made last December (1966) to replace the .30-caliber rifles in the Army inventory with the M-16. The subcommittee questions the accuracy of Dr. Brooks' testimony in the light of Secretary Vance's memorandum dated January 14, 1967, which requested information by August 1, 1967, on items 1, 2, and 3 above, and by May 1, 1967, on item 4 above on which a decision would be based.

Apparently, the decision was made to replace the .30-caliber weapons in the Army inventory with the .223-caliber M-16 rifle. However, that decision and the question of ultimately replacing the M-14 rifle with the M-16 is not documented by testimony received or information furnished to the subcommittee.

SOLE SOURCE PROCUREMENT OF AR-15

The first major procurement of the AR-15 rifle was made in May 1962, by the Air Force for a total quantity of 8,500 rifles and spare parts and ammunition. This procurement of the AR-15 by the Air Force was to equip guard and security forces. Later, in October 1962, the Army procured a small quantity of 338 rifles for test and evaluation purposes.

The Air Force procured an additional 19,000 AR-15 rifles and spare parts in April 1963. This quantity was increased by the letter contract dated November 4, 1963, by an additional quantity of 104,000 rifles of which 85,000 were procured for the Army.

The 1963 decision by the Army to procure the AR-15 was authorized to equip airborne, assault and the Special Forces. This allegedly was then intended as a one-time-only procurement. A direct bearing on the Army's decision to order the AR-15 was the Secretary of Defense's disapproval of the Army's request to continue to procure the M-14 to replace all of the M-1's.

Prior to the negotiations for the fiscal year 1964 buy, the Army decided to include in its request for quotation (RFQ) a provision to obtain a complete technical data package including manufacturing rights for the AR-15 rifle. The justification for this action was to obtain competitive procurement on the follow-on buy of AR-15's and spare parts, and also to eliminate the high royalty of 15 percent paid for repair parts.

On September 3, 1963, Colt's responded to the RFQ dated August 3, 1963, and rejected the Army's request for quotation on the procurement of the technical data package and the manufacturing rights for the AR-15. Colt's letter stated:

Should the sum total of requirements for this rifle exceed 500,000 units, we will at that time consider licensing other sources of production and providing manufacturing know-how to them."

Colt's also stated that it did not intend to propose as a part of or in conjunction with the present procurement of 104,000 rifles to sell or license all or any portion of its proprietary rights to the U.S. Government.

The nature of this response was unquestionably a direct refusal by Colt's in light of the fact that up to that time only about 28,000 AR-15's had been sold to the U.S. Government and the RFQ contemplated an additional procurement of approximately 104,000 rifles and repair parts. Subsequently, Colt's clarified its position on this point on September 30, 1963, when it advised the Army that they had not meant to imply that Colt's would never consider such a sale of licensing, but as previously stated, "Colt's will consider licensing other sources of production and providing manufacturing know-how to them at such time as the total requirements for this rifle shall exceed 500,000 units."

¹² Emphasis added.

A meeting was held in the Office of the Assistant Secretary of the Army Ignatius on October 4, 1963, to discuss Colt's refusal to negotiate with the Army for the proprietary rights to manufacture the AR-15 for the fiscal year 1964 procurement. A memorandum for the record on the meeting, signed by Lt. Col. Arthur G. Moors, indicated that the request to attempt to procure these rights stemmed from the Assistant Secretary's impression that Department of Defense instructions called for competitive procurement. Further discussion ensued on this point and the memorandum shows as follows:

It was pointed out that the Secretary of Defense had approved the procurement plan for sole-source procurement of the rifles and competitive procurement of the ammunition subsequent to this letter. Secretary Ignatius then stated he fully understood why it would be difficult to negotiate with Colt for proprietary rights on such a small quantity of rifles. After some discussion of the problem and further review of the background, Secretary Ignatius stated it was his opinion we should amend the RFQ to delete the requirement regarding "Technical Data Package" for the fiscal year 1964 procurement and that negotiations should be continued with Colt after the award to obtain proprietary rights in the event of a possible future requirement. . . .

The meeting resulted in the Assistant Secretary's decision to "amend the RFQ for this buy to delete the requirement (for proprietary rights of manufacture) and to continue to negotiate after award in the event of a new requirement in the future."

The Commanding General, Army Weapons Command, Maj. Gen. Nelson M. Lynde, Jr., when notified of the Assistant Secretary's decision on October 4, 1963, stated "he thought we were in a position where it would be very difficult to negotiate the rights necessary for competitive procurement in the future, but apparently the decision has been made."

An undated "résumé of award" on the procurement of the 104,000 rifles from Colt's, prepared by J. C. Linnberg, Chief, Procurement Division, Headquarters, U.S. Army Weapons Command, stated that "on 4 October 1963, a briefing was presented to Major General Lynde covering the results of the negotiations held with Colt's. *The General approved the prices as negotiated and directed the preparation of the approval of award for submission to higher authority.*"¹³

It is obvious to the subcommittee that the Government never fully recovered from the Army's failure to push through an agreement to obtain the rights in 1963 at the time of the first large military procurement of the AR-15. Unquestionably, the Government was in its best bargaining position at that time and lost the advantage. Available information indicated that there appeared to be no particular urgency to this procurement; it was considered to be a one-time buy, even though at least two Army studies indicated a possible requirement of well over 500,000 AR-15 rifles during the next 5 years. The rifle was procured by the Army as experimental; the proponents for and defenders of the M-14 rifle were opposed to the small caliber weapon; and the contractor had no real customer for its product other than the U.S. Government.

Armed with information available only to the Army, it seems to the subcommittee, therefore, that the military was in a favored position to not only negotiate a binding agreement for the rights in the event that a follow-on requirement developed for the weapon, but also that a reasonable price for the rights could have been negotiated.

Over 2 years elapsed before another significant order for the AR-15 was placed by the Army. On December 7, 1965, Colt's was awarded a letter contract for 100,000 additional rifles—68,000 for the Army and 32,000 for the Marine Corps. The requirement for additional rifles allegedly generated from a Defense decision to equip U.S. troops, and our South Vietnam and Korean allies with this rifle. According to the Army, with U.S. buildup of combat troops and the escalation of the war in South Vietnam, the need for additional rifle procurement became apparent. General Westmoreland, the U.S. commander in Vietnam, also on December 6, 1965, formally requested that U.S. free world and RVNAF ground combat troops be supplied with the M-16 to replace semiautomatic weapons on a phased and selective basis determined by unit mission.

ACQUISITION OF RIGHTS AND DATA

In the interim 2-year period between the first large buy of the M-16 rifle in 1963 and the December 1965 order for 100,000 rifles, the Army had not purchased or reached an agreement to purchase the manufacturing rights for the rifle from Colt's. As a result, since Colt's exclusively owned the proprietary rights, the Army was placed in a position of dealing with another sole-source buy of the M-16 with the disadvantage of paying higher prices than if competition existed and, more importantly, of not filling the requirement of maintaining the security of the procurement base.

The Assistant Secretary of the Army's decision to delete from the 1963 buy the requirement to negotiate for the rights also included the requirement to continue to negotiate for the rights in the event of a new requirement in the future. The Army continued its efforts on an intermittent basis to acquire the rights from Colt's. However, these efforts were primarily informal discussions with the result that verbal offers only were elicited from Colt's as to the terms under which the U.S. Government could obtain a complete technical data package and a manufacturing license covering the M-16 rifle.

The most attractive of these offers was made in October 1964 when four separate verbal proposals were outlined by Colt's as follows:

Proposal No. 1 would establish a price of \$5,400,000.00 for the tech data package on which Colt could give the government a \$10.00 credit on each gun already delivered and to be delivered under existing contracts. This cost is in addition to a 5% royalty. Counting the number of rifles already delivered and to be delivered under present contract this would amount to a credit of \$1,600,000.00 leaving a balance of \$3,800,000.00 to be paid. The tech data package would be delivered on request at any time providing the unpaid balance was made up. Credit would also be given for spare part purchases. This proposal would cover the M-16 rifle, the M16E1 and the two shot burst control, but would not include any technical data for the blank ammunition, grenade launcher or grenade.

Proposal No. 2 provides for an immediate delivery of the tech data package upon a cash payment of \$3,600,000.00 plus a 7½% royalty. In this proposal and Proposal No. 1 no mention was made as to the length of time the royalty payment would continue.

Proposal No. 3 called for a firm commitment of 400,000 guns plus 5% royalty.

Proposal No. 4 called for a cash payment of \$2,500,000.00 plus a firm commitment for 200,000 guns and 50% of all future procurement in addition to a 4% royalty.

¹³ Emphasis added.

The most favorable offer-proposal, No. 1, when interpreted meant that if the Department of Defense would agree to buy 540,000 rifles, the only cost to the Government would have been the 5-percent royalty. At that time, the Army stated the offer was unattractive because there were no indications that Defense would require 540,000 or more rifles in the future. It is interesting to note, however, that this decision again conflicts with a 1962 Army study which for planning purposes considered that the AR-15 would be procured in quantity through fiscal year 1968. Also, the January 9, 1963, Rifle Evaluation Report of the Department of the Army considered a course of action which would have required the procurement of 800,000 AR-15 rifles through fiscal year 1968. Subsequently, in June 1965 when the Army opened the prior discussions relating to the acquisition of the rights and attempted to secure reaffirmation of this offer, Colt presented a different proposal.

This reluctance by Colt's in establishing firm terms for the acquisition of the rights is exceeded only by the Army's failure to formalize its position and negotiate seriously for the rights. The Army's vacillation in this matter is indefensible commencing with the stretching out of the acquisition of the rights over a considerable period of time, the informality of its actions, the indecision involved, and the delays of one type or another.

It is noteworthy to mention that after a 2-year period of simply discussing the acquisition of Colt's proprietary interests in the AR-15, the Army in its December 1965 buy for 100,000 units accepted Colt's argument, rather meekly it seems, that negotiations for the rights would be quite protracted and would certainly delay delivery of the rifles. As a result, the Army because of the stated urgency for the rifle due to Vietnam requirements decided to award the contract without including a provision in the contract binding Colt to negotiate for the rights. Subsequently, on June 17, 1966, the date of definitization of the letter contract, the Army's perseverance finally showed concrete results as a provision was incorporated into the contract whereby both the Army and Colt's agreed to negotiate in good faith so that the Government could obtain an irrevocable, nonexclusive license to manufacture, or cause to be manufactured, Colt's AR-15 rifles. The provision also stated that the negotiations for such rights and for the technical data package were to be completed on or before December 1, 1966. This, then, was the first time a formal commitment was obtained by the Army to negotiate for the rights in a serious manner. However, the subcommittee notes that this target date was missed by 7 months.

It is inconceivable that the search for the "right terms" under which the Army would consider acquiring the rights for the AR-15 rifle could have continued for so many years without bringing the contractor to the negotiation table in a formal manner, particularly in view of the continued congressional interest in the rights for the purpose of establishing a second production source since 1963, and the innumerable times that various congressional Members of both bodies had inquired into this matter. Time and time again, Defense witnesses testified that they understood the Government's policy. They also testified in a manner indicating that *active* negotiations were taking place on the acquisition of the rights when in fact very little was being done.

For instance, supplemental information submitted to support the February 21, 1966, testimony of Lt. Gen. W. W. Dick, Jr., Army Chief of Research and Development, before the House Armed Services Committee indicated that "the Army has submitted a proposal to Colt's to obtain the production rights in order that Colt's will not be the sole-source producer in the future" (p. 8363, Posture hearings). Also, Secretary McNamara advised the Congress less than 3 weeks later when he testified to the committee (p. 7572, 1966 Posture hearings):

... As far as the M-16 is concerned, Mr. Chairman, I believe I am correct in saying that we are already discussing the possibility of a second source, and I think I am correct in saying Colt has not made it at all difficult for us to obtain a license.

Yet, the records made available to the subcommittee during our investigation reveal that no formal contact between the military and Colt's apparently had been made on this subject for the previous 9 months, June 9, 1965, to March 9, 1966. In fact, it appears that after a conference on June 9, 1965, between Mr. Paul A. Benke, president of Colt's, and Mr. Kendall M. Barnes, General Counsel of the Army Materiel Command, the next contact on the subject of production rights was not until April 13, 1966. On that date a letter was sent by Mr. Barnes to Mr. Benke with a draft of a proposed license agreement, which was not accepted by Colt's.

It wasn't until June 19, 1966, that the Army converted the letter contract of December 6, 1965, into a definitive contract. This was done as a modification to the original letter contract and increased the quantity of rifles on contract from 100,000 to 403,905. The definitive contract also contained a section headed "Negotiation for Government Acquisition of Technical Data Package and License To Manufacture." This section clearly stated that "Negotiations for such rights and for the technical data package are to be completed on or before December 1, 1966."

It is a matter of history now that the Army finally purchased the rights on June 30, 1967. As suspected under the terms of the agreement with Colt's, the Government will pay handsomely for the rights. The basic terms commit the Government to pay:

- (a) \$1,500,000 in cash;
- (b) A royalty of 5½ percent of the selling price to the Government on all weapons and repair parts sold to the Government by sources other than Colt's;¹⁴ and
- (c) The Government agreed to contract with Colt's (on a sole-source basis) for delivery of 27,500 weapons per month each month through April 1968, and each month for 24 months thereafter except July, for which only 13,750 are to be delivered.

This agreement clearly guarantees the procurement of an additional 632,500 rifles from Colt's through April 1970.

There is no question that Colt's dictated the terms and the Government could either accept those terms or continue the risk of depending on only one producer which could be critical for a major weapon in the event of a production stoppage or slowdown of work effort. Such a work stoppage occurred at the Colt plant almost immediately after the signing of the contract.

¹⁴ Even though Colt's pays only 3-percent royalty on sublicenses.

The Secretary of the Army testified before the House Armed Services Committee in April 1967, in answer to a question on the status of licensing a second source to produce the M-16, that "It has been a tough negotiation." This testimony of Secretary Resor differs from that of Secretary McNamara which was mentioned earlier.

Under the various Air Force and Army procurement contracts for M-16 rifles and the recent agreement relating to production rights, Colt's has received orders for delivery of over 1,400,000 rifles plus repair parts. Colt's production capability has increased from the 5,000 rifles per month objective under the first Army contract of November 1963 to a present capacity of over 27,500 per month.

EXCESSIVE PROFITS BY COLT'S

At the request of the subcommittee, the General Accounting Office conducted an examination of the limited records made available by Colt's to determine profit rates experienced on M-16 contracts.

A 10-percent profit rate was negotiated on all production contracts. The records and information made available by Colt's indicate that profits before taxes were 19.6 percent for calendar year 1965; 16.8 percent for calendar year 1966; and 13.4 percent for the first 4 months of 1967, for an average of 16.8 percent.

The General Accounting Office review of a recent Defense Contract Audit Agency (DCAA) survey indicated that a prior examination of price proposals disclosed a lack of adequate and sufficient support for proposed costs and bases for estimating.

Because of possible deficiencies in Colt's accounting system, the recent profit rates experienced, the amount of questions raised by the Defense Contract Audit Agency in their reviews of Colt's proposals, and in their review of Colt's estimating practices and procedures, the possibility exists that Public Law 87-653 may have been circumvented in the M-16 rifle procurements. (Public Law 87-653 requires reporting by the contractor of the most recent and accurate cost and pricing data on negotiated contracts with the Defense Department.)

It is recommended that the General Accounting Office conduct a complete audit of Colt's military contracts to determine the profit rates experienced, the adequacy of their accounting system and whether the provisions of Public Law 87-653 were circumvented on their military contracts.

ESTABLISHMENT OF A SECOND SOURCE

Subsequent to the Army's negotiating for the production rights and technical data package, a bidder's conference was scheduled by the Army Weapons Command to solicit interest from potential producers of the rifle. Some 25 firms were invited to attend the conference at Rock Island Arsenal, Ill., in mid-September. Before the scheduled date arrived, the conference was postponed to October 3, 1967. On that date, some 21 industrial firms sent representatives to the conference. A solicitation for proposal was issued to each interested firm. The solicitation calls for a two-step multiyear procurement of 167,000 M-16 rifles. However, the Army indicated a possible desire for a Government option to increase this quantity by as much as 150 percent.

The subcommittee is advised that the technical data package, necessary for proposals to establish a second source, will not be available

until January 1968. Direct proposals are to be submitted on or before February 5, 1968, with firm fixed-price proposals to be submitted by May 10, 1968. Under the schedule outlined, first deliveries of rifles from a second source are not anticipated before August 1969.

MOBILIZATION BASE FOR M-14 RIFLES

During the procurement of the M-14 rifle, the Army established three industrial producers and furnished Government production equipment valued at almost \$19 million. Since the last procurement of M-14's 4 years ago, more than \$2 million has been expended to maintain the production equipment at all three facilities in a standby condition.

In view of the reported Defense decision in December of last year to replace all .30 caliber rifles with the M-16 and the subsequent adoption in February of this year of the M-16 as a "standard" weapon, the subcommittee finds it hard to understand why it is necessary to continue to maintain such a broad mobilization base for a weapon that hasn't been procured since 1963. According to information furnished the subcommittee between 75 and 95 percent of the M-14 production machinery could be used to produce M-16 rifles.

In view of these facts, the subcommittee recommends that serious consideration be given to utilizing the equipment and facilities of at least one of these rifle mobilization designees for the production of M-16 rifles.

VIETNAM INVESTIGATION

Shortly after beginning its review of the M-16 rifle program, the subcommittee witnessed two malfunctions during firing demonstrations on the range at Fort Benning, Ga., and Camp Pendleton, Calif. Many reports of similar or worse malfunctions being experienced in Vietnam continued to come to our attention. In view of these reports and the malfunctions personally witnessed by members of the subcommittee, the chairman of the House Armed Services Committee, the Honorable L. Mendel Rivers, directed the subcommittee to visit Vietnam and attempt to determine the extent of the problem and the possibility of immediate corrective action, if such were necessary.

The subcommittee departed for Vietnam on June 1 and returned on June 11, 1967. While there we visited units representing all infantry divisions of both the Army and the Marine Corps in Vietnam. In addition, meetings were held with logistics support and maintenance personnel at various levels.

Army problems with the M-16

At Headquarters, U.S. Army Vietnam, the subcommittee was briefed on problems experienced by several Army units last fall and first reported in October. At the request of this Army headquarters, a technical assistance team consisting of representatives of the Army Weapons Command and Colt Firearms was sent to Vietnam on October 19, 1966, to determine the cause and solution for excessive malfunctions being experienced with the M-16 rifle. The technical assistance team, organized into four units of two men each, visited units throughout Vietnam during the period October 21 through December 7. Classes were held for the purpose of providing maintenance instruc-

tion to the military personnel. The following was contained in their report dated December 15, 1966, which was addressed to the Commanding General, U.S. Army Materiel Command:

In all classes the students brought their own weapons, magazines, ammunition, cleaning material, and accessories. A detailed inspection of each weapon, as well as the ammunition and magazines, revealed that with the exception of the 1st Brigade of the 101st Abn Division, the 173d Abn Brigade, and the 5th Special Forces Group, the weapons were in an unbelievable condition of rust, filth, and lack of repair. The filthy condition ranged from actual dirt, grit, and mud on various components of the weapon and ammunition to a heavy carbon deposit on various components. The most significant trouble spots were the chamber, the outside of the gas tube extension in the upper receiver, and the inside of the carrier key. Questions asked of the students in the 1st and 2d echelon classes revealed (with the exception of the three units mentioned) that the weapons had been issued to the units just before they came to Vietnam or after they were in Vietnam, CONUS replacements had had training in marksmanship only, there was a shortage of technical manuals, and there was a shortage of cleaning equipment, there was a shortage of repair parts, and there was a shortage of officers and NCO's who knew anything about maintenance of the rifle.

The report by the technical assistance team further states:

In all units there was a lack of attention to the magazines and ammunition. Both were inspected during the 1st and 2d echelon classes. Approximately 5% of the ammunition was unserviceable due to corrosion and an additional 10% would have given trouble due to being dirty. From 30 to 50% of the magazines appeared to be unserviceable due to bent or spread lips.

The technical assistance team also reported that:

The instruction given by the team, if properly disseminated and followed up, will alleviate most of the difficulties and the rifles will perform well. The shortages of repair parts, cleaning materials, and technical manuals are basically an internal problem within Vietnam which can be corrected only by command emphasis by USARV and the commanders of the units concerned.

It is concluded that the malfunction problem with the XM16E1 rifle did exist and was the result of insufficient training of the personnel prior to using the weapon; a shortage of technical manuals, repair parts, and cleaning equipment; a lack of knowledgeable officers and NCO's and an apparent lack of CONUS emphasis on maintenance training.

The subcommittee was advised that the technical assistance teams achieved outstanding results as units implemented maintenance procedures they prescribed. We were further advised that:

To spread the gospel, command directives and messages from the Military Assistance Command and this headquarters have stressed the need for adequate command supervision of maintenance programs. Command emphasis also has been placed on the importance of maintenance through the use of "advertisement" type publications such as the USARV *Combat Lessons Bulletin* and a special USARV Pamphlet 750-5 on preventive maintenance of the M16A1. The aforementioned publications have received wide dissemination to company level in USARV. *The pamphlet is distributed to every soldier.*

The subcommittee later discovered that the referenced pamphlet on preventive maintenance had not been distributed to individual Marines at the time of our visit. However, 5,000 to 10,000 copies had been requested by the Marines.

A serious malfunction of the M-16 was reported to be the failure to extract the spent cartridge. The Army Weapons Command contends that the major cause of this type failure is not the design of the weapon, but rather inadequate cleaning and a failure to replace worn components. To emphasize proper operator maintenance, the Weapons Command, on October 25, 1966, made wide distribution of a list of instructions that were considered essential to overcome or substantially





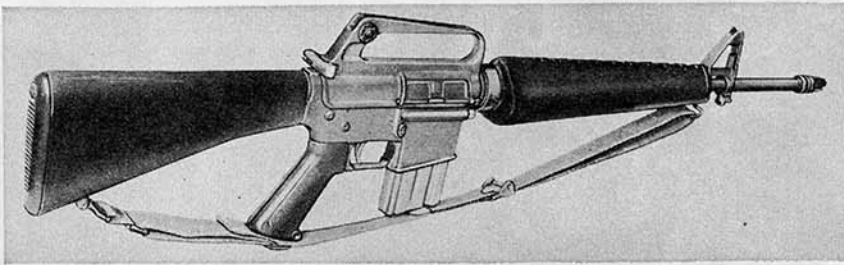

U.S. Rifle M16, Caliber 5.56mm



U.S. Rifle M16A1, Caliber 5.56mm

U.S. Rifle M16A1,
Caliber 5.56mm
(note bolt closure push rod)

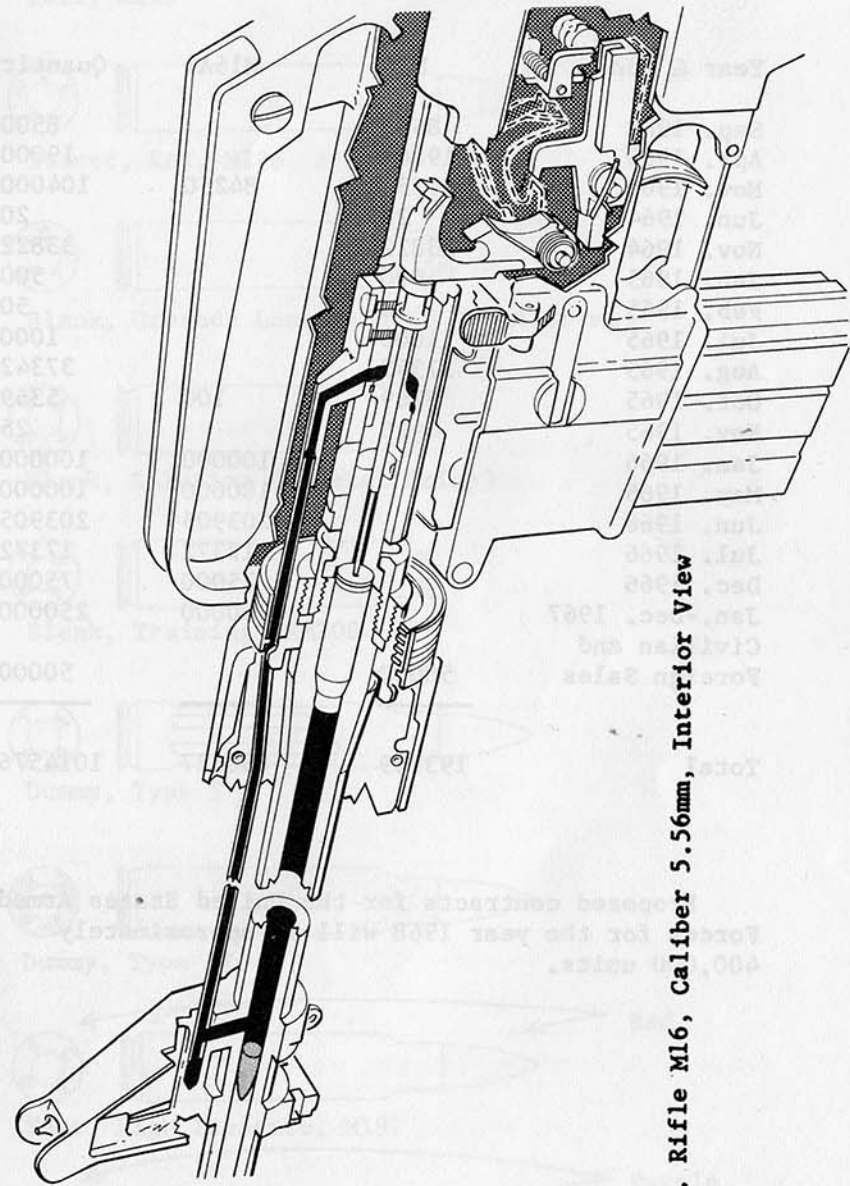

U.S. Rifle M16, Caliber 5.56mm, Interior View

PRODUCTION QUANTITIES OF RIFLE M16 AND M16A1

Year & Month	M16	M16A1	Quantity
Sep. 1962	8500		8500
Apr. 1963	19000		19000
Nov. 1963	19750	84250	104000
Jun. 1964	20		20
Nov. 1964	33822		33822
Jan. 1965	500		500
Feb. 1965	50		50
Jul. 1965	1000		1000
Aug. 1965	37342		37342
Oct. 1965	5269	100	5369
Nov. 1965	25		25
Jan. 1966		100000	100000
May. 1966		100000	100000
Jun. 1966		203905	203905
Jul. 1966		17372	17372
Dec. 1966		75000	75000
Jan.-Dec. 1967		250000	250000
Civilian and Foreign Sales	50000		50000
Total	193949	830627	1014576

Proposed contracts for the United States Armed Forces for the year 1968 will be approximately 400,000 units.

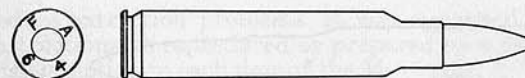

Ball, M193

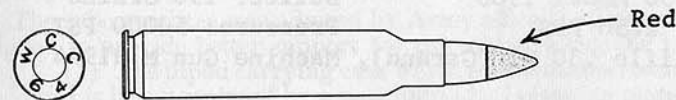

Tracer, Red, M196

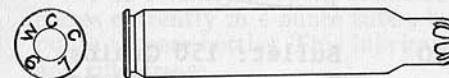

Blank, Grenade Launching (8 Petal Crimp)

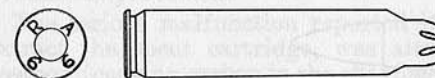

Blank, Saluting (5 Petal Crimp)

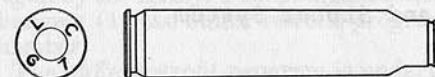

Blank, Training, XM200

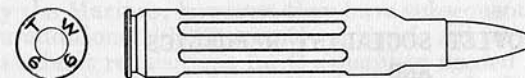

Dummy, Type I



Dummy, Type II

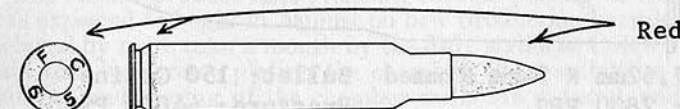

Test, High Pressure, M197

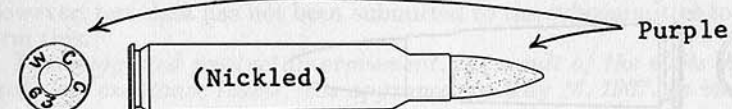

Test, High Pressure, M197 (Alternate Marking)

UNITED STATES



Caliber .30 Model 1906 Bullet: 150 Grains
 Velocity: 2750 FPS Pressure: 50000 PSI
 Weapon: Rifle .30 M1 (Garand), Machine Gun M1919A4

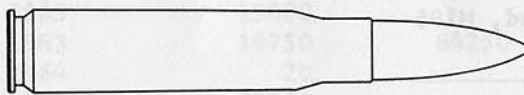

Caliber 7.62mm X 51mm NATO Bullet: 150 Grains
 Velocity: 2750 FPS Pressure: 50000 PSI
 Weapon: Rifle M16, Machine Guns M60 and M73

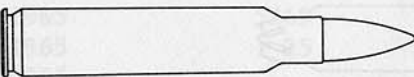

Caliber 5.56mm X 44.5mm Bullet: 55 Grains
 Velocity: 3250 FPS Pressure: 52000 PSI
 Weapon: Rifles AR15, M16 and Stoner System

UNION OF SOVIET SOCIALIST REPUBLICS
 AND
 COMMUNIST CHINA

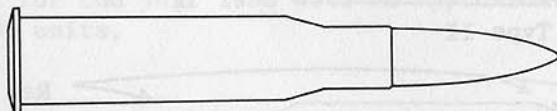
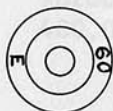

Caliber 7.62mm X 54mm Rimmed Bullet: 150 Grains
 Velocity: 2800 FPS Pressure: 44000 PSI
 Weapons: Rifle M91 Moisin/Nagant, Maxim Machine Gun



Caliber 7.62mm X 39mm M43 Bullet: 122 Grains
 Velocity: 2400 FPS Pressure: 42000 PSI
 Weapons: Rifles SKS46, AK47, Machine Gun RPD

reduce extraction problems. It was suggested that this short list of instructions be reproduced or prepared on a local basis for immediate dissemination to each user of the M-16 rifle. *At the time of the subcommittee's visit there was no evidence that this had been done.*

Changes in support of M-16 rifles

The subcommittee was advised by Army officials of two changes designed to provide better support for the soldier using the M-16 rifle:

(1) The bipod carrying case which also contains cleaning material is being replaced by a new individual cleaning materials case. The new case is much smaller and will contain a newly designed four-piece cleaning rod.

(2) A recently adopted standard lubricant (MIL-L-46000A) comes currently in 4-ounce tubes, but will be available soon in 2-ounce squeeze bottles. This lubricant replaces the preservative oil and rifle grease.

These items were not in the hands of the troops at the time of the subcommittee's visit.

Product improvement

The serious malfunction reported in October 1966, the failure to extract the spent cartridge, was attributed to overlubricating the weapon (causing carbon in the chamber according to the Army), dirty ammunition, and failure to replace worn parts. Reportedly, in recognition of potential problems, a product improvement program was begun by the Army. This program consists primarily of two important changes: (1) the buffer retrofit program, and (2) chrome plating the chamber.

The buffer retrofit program is underway now, and instructions have been given to the field for its implementation. However, at the time of the subcommittee's visit, only 12,500 of the 50,000 modified buffers received in Vietnam had been distributed; none had been received by the Marines; however, they have subsequently received 10,000 with an additional 12,292 recently shipped. All units have been instructed to submit requisitions for the quantity needed along with serial numbers of the rifles to be modified. The new buffer is designed to reduce slightly the cyclic rate of fire. *If this was intended to improve the weapon and reduce certain malfunctions, it is difficult for the subcommittee to understand the lackadaisical manner in which it was implemented. Administrative issue of the new buffers should have been made as soon as possible after arriving in Vietnam with reporting from the units after the fact. Distribution could have been made on a pro rata basis while accounting procedures were being established.*

The second product improvement, chrome plating of the chamber, was expected to begin in August on new production barrels. This was delayed by more than a month by the July strike at Colt's plant. It is said that by chrome plating the chamber, the possibilities of carbon buildup and scoring of the chamber walls are reduced, and cleaning of the weapon is facilitated. A test of a few weapons in Vietnam with chrome chambers reportedly confirmed the value of this improvement; however, test data has not been submitted to the subcommittee to confirm this.

This suggested product improvement, the result of the visits by the technical assistance teams, was approved on May 26, 1967. In view of

its importance, the subcommittee is greatly disturbed by the timelag of over 4 months before the improvement is reflected in the production line. The subcommittee observes that if this product improvement that allegedly will eliminate or drastically reduce the extraction problem, it should have been accelerated and incorporated into production rifles as soon as possible.

During 1967 two additional Army Weapons Command teams have visited Vietnam as followup on the recommendations made by the first team and to provide additional training and technical assistance to the soldier. The latest team was in Vietnam during the first 2 weeks of May. Their report dated May 25, 1967, stated that the team "examined large numbers of M-16A1 rifles in the hands of troops with primary emphasis on determining the status of maintenance, availability of cleaning materials, and the condition of rifle barrels and chambers."

The report contained the following:

The Army units contacted report little or no problems with the M-16A1 rifle. The extraction problem still exists to some degree, but the frequency with which this malfunction occurs has been reduced and minimized due to the increased emphasis on care and cleaning at the unit level, increased logistical and command emphasis on making cleaning materials available and the continuing education program in effect to teach the soldiers how to avoid the problem. The personnel of all ranks with whom I spoke expressed satisfaction with the weapon and agree that it is superior to the M-14 rifle in this tactical environment.

The Weapons Command team reported that a condition frequently observed was the accumulation of thick deposits of copper fouling in the rifle bores. "This condition appeared worse in those units which habitually fire a large volume of tracer ammunition. In one brigade it was reported that 800 barrels had been replaced in recent months due to this condition alone."

The May 25 report indicated that all Army units except one had an ample quantity of cleaning material on hand. The one unit had recently arrived in Vietnam and had not had as high usage of cleaning items as the other more well-established units; therefore, its requisitioning objectives had not been as high. It was stated that this one unit did have some quantity of all items on hand.

The Army Weapons Command team concluded in its May 25 report:

The M-16A1 rifles in the Army units visited were in good condition. Logistical and Command emphasis on making cleaning materials available and the continued education and emphasis on care and cleaning have contributed significantly to the reduction of weapon malfunctions. Amazingly few weapons were found in the shops awaiting repairs and no weapons were found to be unrepairable due to a lack of parts.

The major problem found was the deterioration of rifle barrels due to chamber pitting and accumulation of copper fouling. The chamber pitting may be due to the previous short supply of cleaning materials and previous lack of emphasis on the need for frequent and thorough cleaning. The copper fouling may be attributed to the use of a large volume of tracer ammunition.

The team recommended:

(1) That both tactical and logistical units continue to stress the importance of frequent and thorough cleaning of the M-16A1 rifle, with particular emphasis on the chamber and bore.

(2) That continued emphasis be placed on making cleaning materials available to the troops. This emphasis must continue throughout the pipeline—from manufacturer to ultimate user. The selective management techniques presently being employed to insure an adequate supply of these items must continue until

such time as all needs have been met and the pipeline is sufficiently filled to permit return to normal supply procedures to satisfy requirements.

(3) That Division and Separate Brigade T/O & E's be reviewed by appropriate agencies to determine if the number of Small Arms Repairmen MOS 42110 (45B20) authorized in organic Direct Support Maintenance units is adequate to support the assigned weapon densities. In those units where the repair requirements exceed the capability of organic personnel, assistance should be sought from back-up support DS and GS units assigned to the 1st Log Command.

(4) Field Commanders should be advised of the potential problems associated with the use of tracer ammunition. Tracer ammunition characteristically leaves more fouling in rifle bores, causes more rapid deterioration, and necessitates more frequent and thorough cleaning. It is recommended, therefore, that the use of tracer be limited to the least proportion which provides the necessary visual display for any particular tactical situation. The use of tracer for general purpose ammunition should be discouraged.

(5) That a supply control study be conducted by the Supply and Maintenance Directorate, U.S. Army Weapons Command, to determine if present rifle barrel production is adequate to support the anticipated usage of barrels (estimated 10% per quarter). If the study indicates a requirement above present production capacity, additional production capability should be added as soon as possible.

(6) That U.S. Army agencies charged with the responsibility for small arms product improvement continue to seek methods of reducing rifle malfunctions. Of primary importance is the extraction problem which is aggravated by pitted chambers. Pitting and deterioration of rifle chambers is caused by improper or insufficient cleaning. Suggested as a possible product improvement is chromium plating of rifle chambers. Another product improvement presently being incorporated in new rifle production and as a part of an existing retrofit program is the replacement of the present buffers (Guide Assembly, Action Spring (62219)) with a buffer of improved design. This program must be closely monitored by all responsible agencies to insure that it is completed without delay.

(7) That the improved lubricant (MIL-L-46000A) recently adopted as the preferred lubricant/preservative for M-16A1 rifles be procured and distributed to the field as soon as possible. Once made available, every practical means should be used to disseminate the proper lubrication/preservation procedures to the using units. In addition to timely changes to appropriate technical manuals, such media as PS Magazine and AFRS Radio and TV should be considered as a means of disseminating this information.

(8) That a borescope, similar to the AMCI Borescope manufactured by the American Cystoscope Makers, Inc., be procured and issued to all Direct and General Support units with an M-16A1 rifle support mission to permit closer inspection of rifle chambers and bores. No visual aids are presently available to the maintenance personnel to perform this inspection.

Interviews with Army combat personnel

During our visit to Vietnam the subcommittee interviewed combat personnel from the delta area of the south to the demilitarized zone (DMZ) in the north. Hundreds of GI's were questioned on their experiences with the M-16. Among the Army units visited in the II Field Force area, only two soldiers stated a preference for the M-14 over the M-16. Many had experienced malfunctions in the past but few were now having any problem. Most Army units were required to clean their weapons prior to going out on patrol and upon return. One unit of the 1st Infantry Division had just returned from patrol before our visit. They reported that in testing their weapons upon return, 20 rounds were fired in each weapon with only two weapons out of 154 failing to fire. The two malfunctions were readily cleared by hand and were not considered serious.

The men of the 173d Airborne Brigade stated that they had no problems with the M-16 rifle as long as it was properly assembled and adequately cleaned. They stated that under extreme conditions, the unit commander issued orders during halts and rest periods for half

of the men to disassemble and clean their weapons while the other half remained ready for action. This practice was repeated whenever possible. The men stated a preference for the M-16 but indicated that it required more detailed and frequent cleaning than does the M-14. An armorer of this unit was of the opinion that chrome-plating of the chamber would make the weapon much easier to clean. A company commander of this unit stated that he had instructed his men to use tracer ammunition only when necessary because of his belief that it was harmful to the weapon. The unit commander stated that he was completely satisfied with the M-16 rifle and wanted no other weapon under this type combat condition. The unit had no trouble getting adequate cleaning equipment. The officers and NCO's of the unit supervised the cleaning and care of the rifle.

A unit of the 4th Infantry Division that had just completed a severe firefight stated that they had very few malfunctions during the fight. It was their experience that some magazines would hold 20 rounds while others would take only 19. Because of this inconsistency, the members of the fire teams loaded only 17 to 18 rounds to insure that the weapon would fire the first time. The platoon leaders supervised the daily cleaning of the rifles and the loading of the magazines. This unit believed that the magazine and ammunition played a great role in the malfunctions experienced.

The information obtained from members of the other Army divisions visited was very similar with the exception of the 1st Cavalry Division and the units participating in Task Force Oregon. Of approximately 75 members of the 1st Infantry Division units in Task Force Oregon, almost 40 percent stated a preference for the M-14 rifle over the M-16. Malfunctions experienced were: selector switch sticking, stoppage due to dirty ammunition, failures to extract, and failures to extract rounds left in chamber overnight. There was evidence of some shortages of cleaning materials. Some men were having to share cleaning rods.

Of the 30 members of the 1st Cavalry Division interviewed, 21 had experienced failures to extract at one time or another. Some of these men lubricated the ammunition in the magazine, which is not in accordance with instruction. At least four of the men interviewed did not have cleaning rods and a similar number were without brushes.

The information received from the 1st Cavalry Division was most disturbing in view of the December report of the Army Weapons Command technical assistance team, which stated:

1st, 2d, and 3rd echelon instruction was not given to the combat brigade of the 1st Cavalry Division. This Division stated that they were not having any trouble with the rifle and requested that the instruction be given only to the small arms shop of their maintenance battalion.

The instructions for preventive maintenance, mentioned earlier in the report, which reportedly was to have been distributed to every user of the M-16 rifle, had not been received by the men of the 1st Cavalry Division at the time of our visit. The units of the 1st Infantry Division participating in Task Force Oregon were also without the preventive maintenance pamphlets and the cleaning instructions to prevent extraction problems.

Interviews with Marine Corps combat personnel

Interviews were conducted with units from all Marine regiments presently in Vietnam. Of the Marines interviewed, approximately 50

percent had experienced some type of malfunction such as: failure to fire, failure of the bolt to close, failure to feed, failure to eject, failure of the selector lever, and failure to extract. Of these malfunctions, the most prevalent and most serious is the failure to extract, which comprised about 80 percent of the total malfunctions. Most, if not all, of the others can be corrected with the individual's bare hands or by using a knife or bayonet. In the case of a failure to extract, it usually requires a forceful push of the cleaning rod from the muzzle of the rifle barrel. Since the cleaning rods are to be carried disassembled in the carrying case, it takes time to locate and assemble the rod before one can remove the stuck cartridge. If a soldier fails to carry a cleaning rod, this necessitates borrowing a rod from another soldier, hopefully nearby.

The reported death of one corporal, killed while running up and down the line of his squad pushing out cartridges which failed to extract with the only cleaning rod in the squad, was confirmed by our investigation.

One battalion commander, who was no longer with the unit, gave instructions to the battalion armorer to issue only one cleaning kit for every four men. In case a cleaning rod was lost or broken this meant further doubling up in the use of this vital equipment. At the time of the subcommittee's visit this situation still prevailed in at least one company. Prior to our departure from Vietnam, cleaning kits had been issued to each man in that company. However, the cleaning kits did not include the new lubricant which was reported to be in Vietnam at the time.

Because of the malfunctions personally experienced or reported by others, many of the Marines lacked confidence in the M-16 rifle. In addition to the malfunctions experienced, much of the dissatisfaction with the M-16 might be attributed to a lack of proper training and familiarity with the rifle. None of the enlisted Marines had possession of preventive maintenance pamphlets, manuals, or other written instructions. Many had received very little oral instruction in the care and cleaning of the weapon. While it was reported that sufficient cleaning materials were on hand at the battalion levels, numerous shortages were noted at the company and squad levels.

Several of the Marine units visited had no organized supervision in the care and cleaning of the rifle. In checking the rifle of one Marine who had returned from a patrol some 14 hours earlier, it was found to be clogged with wet sand. Daylight was not visible through the barrel. It is suspected that the rifle would have exploded had it been fired in that condition. However, that same Marine had fired over 500 rounds with the M-16 rifle in combat and had experienced only two failures to extract.

Many of the M-16 rifles issued to the Marines contain the new buffer, designed to slow down the cyclic rate of fire; however, these new weapons are still experiencing failures to extract. The subcommittee was advised prior to going to Vietnam that the rifles produced after December 1966 have the improved buffer (action spring guide assembly). It is noted that the reason given by the Army for this product improvement was "to improve reliability by reducing cyclic rate and eliminating possible bolt carrier bounce and increase parts life." Therefore, the subcommittee questions the effect this "product improvement" will have on the problem of failing to extract.

One possible cause of malfunctions of Marine rifles is the use of an improper cleaning solvent. The accepted cleaning solvent for the chamber and bore of any weapon is a commercial cleaning solvent. Many of the marines questioned were using diesel oil to clean the chamber and bore of the M-16. According to technical publications, this is not the proper cleaning material to clean the weapon of corrosion, carbon, and other chemicals resulting from firing the weapon.

While in Vietnam, the subcommittee received suggestions from several of those interviewed that the ammunition should be checked as a possible cause of malfunctions. This was done upon our return and is covered in the next section of the report.

AMMUNITION

According to Dr. Wilbur B. Payne, Chief, Office of Operations Research, Army, for 26 years the military has been locked into a sole-source procurement of a propellant for which the design objective was to permit reuse of scrap and surplus cannon powder.

Dr. Payne stated in a memorandum of February 10, 1967, to the Under Secretary of the Army that ball propellant was adopted with a total absence of comparative tests from the time of its adoption to the M-16 rifle experience.

Ball propellant was adopted by the U.S. military for .30 caliber carbine ammunition in 1942. The Army adopted ball propellant in 1951 as the "preferred" propellant for caliber .30 and caliber .50 ammunition. Ball propellant was adopted in 1953 as the "standard" for .20 mm., M-50 series ammunition, and also as the "standard" for 7.62-mm. ammunition.

In April 1954, the Chief of Ordnance directed that all military small arms ammunition should eventually be loaded with ball type propellant powder which was (and is) produced only by Olin Mathieson.¹⁵ This is a double-base (nitrocellulose-nitroglycerine) propellant commonly called ball powder and is a spherical grain coated with dibutylphthalate.

The M-16 (AR-15) rifle was initially developed, tested, and evaluated using commercial ammunition loaded with IMR 4475 propellant. The initials IMR stand for improved military rifle. IMR 4475 is a grade of rifle powder first introduced by the Du Pont Co. in 1936 for use in both military and commercial cartridges.

Propellants of this type are single-base (nitrocellulose) tubular-grain and employ dinitrotoluene (DNT) as a deterrent coating to control the rate of burning. Of this type ammunition it is said that the ballistic and chemical stability has been found generally excellent both in accelerated aging tests and in long-term service use. The IMR powder supplied for the 5.56-mm. cartridge is the same, except for minor modifications, as the propellants supplied by Du Pont for military small arms loading since the early 1920's, and was the type used in practically all of the U.S. and most of the British rifle and machine-gun ammunition from caliber .30 through .20 mm. in World War II. IMR 4475 has also been used in loading 7.62-mm. ammunition for the M-14 rifle. Propellants of the IMR type are commercial products exclusively of the Du Pont Co. in the United States.

Between the time the M-16 program was authorized and the placement of the initial contract, there was much discussion before the Technical Coordinating Committee on the problem of establishing an ammunition specification acceptable to all services. The first Air Force procurement of the rifle was accompanied by a procurement of 8½ million rounds of ammunition loaded with a single base extruded propellant (IMR 4475). This ammunition was procured as an off-the-shelf commercial item and was produced under Remington's commercial specification.

It was testified that this Remington ammunition was the same as that used in the rifle during earlier tests by the Air Force, the Army, and the Advanced Research Projects Agency (ARPA). However, during the life of this first ammunition contract, the Air Force received adverse reports from various users. Because of these adverse reports, the Air Force conducted a test at Hill Air Force Base to determine the status of the .223 ammunition then in Air Force inventory. Approximately 1,000 rounds from each of eight lots were tested. These rounds were observed for penetrating ability, function and casualty pressures, velocity, waterproof, accuracy, bullet extraction, and a mercurous nitrate test. The test report dated July 1963 concluded "That the Air Force inventory of caliber .223 cartridges met the requirement of MIL-C-9963A and performance characteristics for the new USAF specification weapon." It was recommended that this ammunition be released for unrestricted field use.

The ballistic specification of the commercial cartridge used in the development and testing of the M-16 included a normal mean velocity of $3,250 \pm 30$ feet per second (f.p.s.) and a mean chamber pressure not to exceed 52,000 pounds per square inch (p.s.i.). In June 1963, Frankford Arsenal issued a report based on examination of the manufacturer's test reports as well as the ballistic testing of chambers at the arsenal which contained the following observation regarding the attainment of the stated commercial ballistics.

While these ballistics are attainable, the achievement of the required velocity has in experience allowed a very small margin below the maximum permissible chamber pressure for most lots of ammunition. For large-scale production of military ammunition (should that hypothetically be contemplated) experience has shown that a somewhat more conservative margin should be maintained between the typical chamber pressure of production lots and the maximum level permitted.

It was recommended at that time by Frankford Arsenal that consideration be given to a reduction in muzzle velocity which would permit lower chamber pressure and a concomitant adoption of an alternate bullet having improved aerodynamic design which would at the same time improve impact energies at all ranges beyond 100 yards. This recommendation was not approved.

The initial Army technical data package for 5.56-mm. ammunition (MIL-C-46381(MU) dated June 26, 1963) was based on the commercial ballistics requirements with only a slight amendment based on further review of commercial manufacturing experience. The mean velocity was specified as 3250 ± 40 f.p.s., while the mean chamber pressure specification remained the same, that is, not to exceed 52,000 p.s.i. The same requirements appeared in three successive revisions of the technical data package. However, an attempt to utilize this specification for military procurement in January 1964 elicited statements

¹⁵ General Accounting Office Report No. B-146977 dated March 31, 1965.

from commercial producers that a relaxation of these requirements was required to enable procurement from them.

On October 8, 1963, the Air Force awarded a contract to Remington Arms Co. for 19 million rounds of ammunition under the USAF specification, MIL-C-9963A, which was coordinated with the Army. The specification called for IMR-4198 propellant and stated that IMR 4475 was considered an equal and interchangeable type propellant. According to the Air Force, the specification further stated that any propellant meeting the pressure, velocity, and environmental requirements of the specification would be considered equal to the propellant specified.

Remington chose to load the ammunition with WCC-846 propellant, a doublebase ball propellant which uses both nitrocellulose and nitroglycerine. The preproduction lot test reports met the requirements of the military specification and all production lots were loaded with the ball propellant.

After a conference of January 17, 1964, between Government and contractor personnel, the maximum acceptable mean chamber pressure was increased to 53,000 p.s.i. It is said that this change enabled the procurement of 1 million rounds required but illustrated the likelihood that some change in design of the commercial .223 cartridge might be required if the stated ballistics requirements were to be met consistently in large-scale production. The 1 million cartridges were loaded with IMR 4475 propellant and were the last ball ammunition to be loaded with IMR 4475.

In February 1964, the Army requested the three U.S. propellant manufacturers to submit candidate propellants for testing as replacements to the IMR 4475. The desired propellant was to allow achievement of the required velocity of 3,250 f.p.s. and a chamber pressure substantially less than that produced with IMR 4475. Further it was required that any propellants to be recommended should not be significantly inferior to IMR 4475 in other characteristics such as smoke, flash, fouling, barrel erosion, storage stability, or performance at environmental extremes and were to be producible in large quantities from available materials in the event of their successful performance and adoption for use.

Based on the tests conducted, the candidate propellant submitted by Du Pont (CR 8136) and the propellant submitted by Olin Mathieson (WC 846) were recommended to be approved for use as permissible alternates to IMR 4475 in the loading of 5.56-mm. ball ammunition. It was concluded that "cartridges loaded with these two propellants afford substantial advantage over IMR 4475 as regards velocity/pressure relationship."

On the fiscal year 1964 ammunition procurements, Olin Mathieson chose to load with WC 846 ball propellant and Remington elected to use IMR (CR) 8136. After production of approximately 50 million rounds loaded with this IMR propellant, Remington again indicated difficulties in meeting the velocity/pressure requirements and began loading with WC 846 ball propellant in December 1964. Of the 132 million rounds of 5.56-mm. ammunition procured during fiscal year 1964, 1 million rounds were loaded with IMR 4475, 50 million with IMR (CR) 8136, and 81 million rounds were loaded with WC 846 ball propellant.

In February 1965 the Army again requested the propellant manufacturers to submit new candidates for the 5.56-mm. cartridge. Du Pont submitted IMR 8208M and Hercules Powder submitted its HC-11. Olin Mathieson reported that they were unable to offer a candidate better than WC 846. Of the two submitted, the one loaded with IMR 8208M reportedly met all requirements and was approved. The Hercules powder failed the fouling test requirement and was disqualified, according to the Army.

The subcommittee notes that samples of ammunition containing propellant candidates were received by Frankford Arsenal in September 1965 for testing; however, it was not until April 1966 that the test reports were approved by the Technical Coordinating Committee and IMR 8208M submitted by Du Pont was qualified and the Hercules submission disqualified. This delayed action indicates to the subcommittee a lack of any sense of urgency on the part of the Army.

Initial production of 5.56-mm. ammunition loaded with IMR 8208M began in May 1966. Deliveries of ammunition loaded with this propellant were not scheduled to arrive in South Vietnam before June or July of 1967. However, the Marine Corps reported that as of August 10, 1967, the Marine units in Vietnam have not received any 5.56-mm. ammunition using IMR propellant.

Fouling test specification

The initial ammunition specification of the Air Force and that adopted for the initial Army procurement failed to include a fouling requirement for acceptance testing. A subcommittee was appointed in March 1964 by the Chairman of the Technical Coordinating Committee to study various proposals for a technical data package for ammunition. At a meeting of the Technical Coordinating Committee on March 24, 1964, the subcommittee recommended an engineering change to the proposed technical data package to include a fouling requirement in the ammunition test procedure. The reason for the change was stated "To prevent the acceptance of ammunition which may cause weapon stoppages due to excessive deposition of residue on firing." As further justification for this change, it was stated that "Ammunition utilized in acceptance testing for Colt has exhibited various degrees of fouling characteristics. In certain lots several thousand rounds may be fired from the weapon (without clearing) without any evidence of malfunction due to fouling. In other lots stoppages have occurred due to fouling in as little as 500 to 600 rounds."

The contractor (Colt's) and the four services agreed that this engineering change should be incorporated into the technical data package with application to fiscal year 1965 procurement. The engineering change required a 1,000-round fouling test to be successfully conducted on each preproduction lot as a condition of acceptance.

The subcommittee notes that this specification calls for testing of fouling characteristics of preproduction lots only and does not apply to normal production lots. Therefore, it is possible for an ammunition contractor to continue to produce ammunition indefinitely without production lots being subjected to this test once the initial preproduction sample has been approved. Under this specification, an ammunition contractor could produce millions of cartridges over an indefinite time period after the first 1,000 rounds passed the fouling test so long

as there was no change in the ammunition specification. (The subcommittee notes one contract with Olin-Mathieson was for 59 million cartridges.)

It is the subcommittee's view that the fouling test should be applied to all production lots of ammunition and not just to the initial preproduction lot in view of the possible malfunctions related to excessive fouling within the weapon.

Increased cyclic rate caused by ball propellant

At this same meeting of the Technical Coordinating Committee, March 24, 1964, a Colt representative remarked that the current Army contract "imposes a cyclic rate restriction of 650 to 850 rounds per minute as a condition of acceptance. The current USAF contract (fiscal year 1963) permits 900 as the upper limit on cyclic rate." He further stated that a recent test conducted at Colt's using 10 weapons and two lots of ammunition resulted in six of the 10 weapons exceeding the cyclic rate test when firing ammunition loaded with WCC-846 ball propellant. Of the 10 tested firing IMR-4475 propellant, one weapon exceeded the upper limit of the cyclic rate by five rounds per minute. Colt's requested that the upper limit of the cyclic rate acceptance requirement be increased to 900 rounds per minute for those weapons delivered during April 1964 on the fiscal year 1964 contract.

Waiver of cyclic rate acceptance test

With reference to the shipment of the first 300 guns scheduled for delivery in March under the Army contract, it was stated that Colt's had been able to meet the cyclic rate problem through selection of weapons meeting the established criteria. The service representatives attending the Technical Coordinating Committee meeting concurred in the request by Colt. However, "it was emphasized that this change would apply only to the weapons delivered in April." This waiver was subsequently extended to production in the months of May, June, and July of 1964. The subcommittee observes from the delivery schedule that under this waiver some 12,400 rifles were delivered and accepted by the Army that failed to meet the intended operational specification. There is no evidence that the Army made any attempt to recall these weapons or determine their operational suitability after it was determined that the high cyclic rate was related to certain malfunctions of the rifle. It is conceivable that a substantial quantity of these rifles was issued to the troops in Vietnam and could be among those exhibiting less than desirable reliability.

(Following the 4-month waiver on the upper limit of the cyclic rate for the acceptance test, Colt's apparently was allowed to select the ammunition used in the rifle acceptance tests. Colt's chose ammunition loaded with IMR extruded powder because of the cyclic rate test and the consistency of favorable test results obtained when firing IMR ammunition. Between the date of incorporating a new buffer in the rifle in production, December 1966, to slow down the cyclic rate, approximately 330,000 rifles were accepted from Colt's by the military. More than 218,000 of these were delivered to the Army. Undoubtedly many thousands of these were shipped or carried to Vietnam, with the Army on notice that the rifles failed to meet design and performance specifications and might experience excessive malfunctions when firing ammunition loaded with ball propellant. It was also known that 90

percent or more of the 5.56 millimeter ammunition delivered to Vietnam was loaded with ball propellant.)

Air Force experience with AR-15

The March 24, 1964, meeting of the Technical Coordinating Committee also included a review by the Air Force representative of the endurance testing data developed at Colt's as a result of the Air Force fiscal year 1963 procurement program. The data presented to the committee indicated that 27 guns had each been fired 6,000 rounds. Malfunctions totaled 55, or one per 3,000 rounds. The parts replacement rate was one per 6,200 rounds.

The Air Force representative, Mr. Aumen, made the following conclusions concerning the weapons being received on the fiscal year 1963 Air Force procurement program:

1. Weapons function well.
2. Require minimum parts replacement,
3. Good velocity life,
4. No apparent decrease in accuracy,
5. Serviceable life beyond 6,000 rounds.

In testimony before the subcommittee, Mr. Aumen indicated that the endurance testing statistics were expanded to include an additional 13 rifles subsequently tested. The last 13 rifles tested gave an average malfunction rate of one stoppage per 6,500 rounds.

The subcommittee notes that the reported reliable performance of the Air Force weapons was obtained with the IMR-4475 propellant even though the velocity obtained was below the specification of $3,245 \pm 40$ feet per second.

The subcommittee was told that IMR-4475 propellant subsequently became unacceptable to the Army and the Air Force because it failed to meet consistently the velocity and pressure specifications of 3,245 feet per second ± 40 feet per second and 52,000 pounds per square inch. However, the rifle didn't seem to realize this and had performed in a reliable manner when firing ammunition loaded with this propellant.

IMR ammunition used for acceptance test

Army witnesses testified that subsequent to the waiver of the cyclic rate for the July 1964 deliveries, Colt's was able to meet the cyclic rate specification by tightening the action spring. The subcommittee observes that the ammunition used for acceptance testing probably was the basis for meeting the acceptance test rather than the reason given by the Army. Colt's chose to use IMR ammunition in their acceptance test rather than ammunition loaded with ball propellant. The Army position on this matter was that there was no indication that malfunctions would be caused by the higher cyclic rate of fire when using ammunition loaded with ball propellant. Therefore, Colt's had the option of using ammunition from the nearest source of supply for their test purposes. The nearest Government producer of 5.56-millimeter ammunition was Remington which at the time was loading ammunition with IMR propellant. However, the subcommittee notes that even after Remington began loading ball propellant in its WCC-846 ammunition, Colt's continued to use IMR ammunition for acceptance tests.

Further evidence of ammunition effect on cyclic rate

The adverse effect on the cyclic rate of fire was further called to the attention of the Army at a June 3, 1965, meeting of the Technical Coordinating Committee and by a report submitted by Colt's dated November 8, 1965, entitled "The Effect of Ammunition Variables on Acceptance Testing of XM-16E1 Rifles." This report was prepared by Mr. W. C. Davis, engineering project manager, Colt's Firearms Division. During the subcommittee's hearing it was brought out that this same Mr. Davis was formerly an employee of Frankford Arsenal, where most of the ammunition testing has been conducted, and he is now a technical assistant to the M-16 rifle project manager, Army Weapons Command, Rock Island, Ill. The report stated that "During testing of production rifles a marked change in the cyclic rate was observed to correspond with a change from ammunition employing tubular-grain propellant to ammunition employing spherical-grain (ball) propellant. Whereas the typical cyclic rate with the former ammunition was quite close to the desired rate of 750 rounds per minute, the typical cyclic rate with the latter ammunition was substantially higher." The test results indicated that the cyclic rate obtained with the rifles firing ammunition loaded with ball propellant exceeded by over 100 rounds per minute that obtained firing ammunition loaded with tubular grain propellant (IMR). The report further stated that aside from the consideration of rejecting rifles presented for inspection on grounds of cyclic rate, there was a probability of more frequent fatigue failures of the bolt when the cyclic rate of fire is significantly increased. It was stated that "there are also certain malfunctions which occur more frequently when the timing of the gun cycle is materially speeded up."

The conclusions contained in the report were as follows:

There is a clearly significant change in typical cyclic-rate performance of XM16E1 rifles, associated with a change in ammunition types, such as those represented by M193 Ball Lots RA5060 and RA5135 respectively. The conspicuous difference between these lots of ammunition is that different types of propellant were employed.

Weapons which readily meet the present cyclic-rate requirement when using ammunition such as Lot RA5060 will frequently fail the present requirement when using ammunition such as Lot RA5135. The increased frequency of failure is ascribable to an increase in both the mean cyclic rate and in the typical standard deviation of cyclic rate. *For weapons such as those used in this experiment, none are likely to fail with ammunition such as Lot RA5060, whereas more than half are likely to fail with ammunition such as RA5135.*¹⁶

The difference in cyclic rate produced by ammunition differences is such that no controls which might be exercised over manufacture of XM16E1 rifles could guarantee compliance with the present limits imposed upon cyclic rate, if both types of ammunition are to be accommodated. It can be estimated, from the foregoing data, that the upper limit must be extended from 850 rds/min to 1000 rds/min to accommodate ammunition of both types.

*The increase in cyclic rate, associated with use of ammunition such as Lot RA5135, can be expected to reduce the endurance of certain parts (notably the bolt), and to increase the frequency of certain malfunctions*¹⁷ (notably the failure of bolt to latch rearward when magazine is empty. The accumulation of data for a quantitative assessment of these effects is not yet available, because many thousands of rounds are necessary for rendering a statistically sound judgment on parts life and malfunction rate. Nevertheless, it is clear that the present allowances for parts replacement, and for certain types of malfunctions, must be increased if ammunition such as Lot RA5135 is to be accommodated in endurance testing of rifles.

¹⁶ Emphasis added.

¹⁷ Emphasis added.

The subcommittee was advised that no further waivers were approved on increased cyclic rates experienced in the acceptance testing. However, Colt's was allowed to use only IMR ammunition for the acceptance tests.

Report of malfunctions related to ammunition deficiencies

At about this same point in time, November 1965, reports were received from the U.S. Army Combat Developments Command Experimentation Command (CDCEC) Fort Ord, Calif., a participant in the SAWS study, that an unusual number of rifle malfunctions were being experienced because of ammunition deficiencies. These reports were later included in the printed report dated May 10, 1966. Included in that report was the following section citing "Major Causes of Malfunctions in 5.56-mm. Weapons."

Major causes of most malfunctions in the 5.56mm weapons are attributed to an interaction of ammunition (and belt link) deficiencies:

1. Weapon fouling, judged to be caused primarily by qualities of the propellant used in standard ball 5.56mm cartridge.
2. Cycling of weapons in excess of design rates, judged to be caused by combinations of:
 - a. Pressure characteristics of the propellant used in the standard ball 5.56mm cartridge
 - b. Factory calibration of M16E1 rifles for a propellant with different pressure characteristics than that in the standard ball 5.56mm cartridge.
 - c. Mismatch in internal ballistic (pressure) characteristics between the standard 5.56mm ball and tracer cartridges.
3. Misfires caused by too low primer sensitivity and possibly (in the case of the Stoner machinegun) an interaction of low primer sensitivity with effects of too rapid weapon cycling caused by the pressure characteristics of the propellant.
4. Incorrectly manufactured machinegun belt links.

a. Fouling.

Fouling in the 5.56 weapons occurred throughout the experiment. Dirty chambers resulting from rapid carbon buildup caused most of the failure to extract. Fouling remained a problem throughout the experiment, although cleaning and inspection of weapons were considered more stringent than would be possible during combat.

*Inquiry to AMC determined that the propellant adopted for the standard 5.56mm ball cartridge is different from the original propellant used during the development and service testing of the M16E1 rifle*¹⁸ and during the development of the Stoner weapons. A USACDCEC test of samples from the lot of standard ammunition used in the experiment showed more fouling than an AMC provided sample containing the original propellant. This supplemental fouling test was conducted using ammunition lots WCC 6008 and RA 5074. This limited test firing of 12,620 rounds indicated a malfunctions rate of 5.6 per 1000 rounds for the cartridge loaded with ball propellant as opposed to 0.91 for IMR propellant loaded cartridges.

b. Excessive cyclic rate.

Excessive cyclic rates were noted early in the experiment. In addition, surging (uneven firing) was noted when ball and tracer were fired together. There was also an increasing incidence of malfunctions attributed to ammunition cycling the weapons beyond their design rates. The cyclic rates were higher than the design cyclic rates, particularly with the M16E1 rifle and Stoner machinegun. Surging also was most noticeable with the Stoner machinegun. It is concluded that this excessive cyclic rate (through induced cyclic and impact problems) caused, complicated, and multiplied such malfunctions as failures of the bolt to remain to the rear after the last round was fired from the magazine, failures to eject, and magazine feeding problems.

A concurrent propellant investigation by Frankford Arsenal showed that the propellant currently used in the 5.56mm ball cartridge cycles weapons faster than the original propellant.

¹⁸ Emphasis added.

Inquiry to AMC determined that, to meet a government acceptance requirement, M16E1 rifles are calibrated at the factory for the gas port pressure of the original propellant rather than that of the propellant currently used in standard ball 5.56mm cartridges. Interaction of the higher gas port pressure of the current propellant and the sizing of the gas port for a propellant with a lower gas port pressure is considered the reason for the excessive cyclic rate in the M16E1 rifle.

Buffer modification

The Army's response to these reported malfunctions associated with the 5.56-mm. ammunition was to design a heavier buffer to slow down the cyclic rate of the weapon. The buffer modification was approved by the members of the Technical Coordinating Committee as early as January 1966; however, it was not incorporated into the rifle production line until December 1966, 11 months later. No evidence was presented to the subcommittee that any attempt was made to improve or correct the undesirable characteristics of the ammunition loaded with ball propellant, even though Frankford Arsenal was instructed on March 29, 1966, to continue to investigate the problems caused by ball propellant and determine what changes to the ammunition purchase description could be made to define acceptable performance with ball as well as IMR propellant. To this date, ammunition loaded with ball propellant still is being procured in large quantities, and millions of rounds of this ammunition are in the inventory of the services both in the United States and South Vietnam.

Ammunition deficiencies called to attention of DOD

The problems experienced with the M-16 rifle and the ammunition loaded with ball powder came to the attention of Dr. Wilbur B. Payne, Chief, Office of Operations Research in the Office of the Secretary of the Army, in November 1965. After analyzing the problem, Dr. Payne submitted a memorandum to his counterpart in the Department of Defense expressing his concern over the problem and the possibilities that the same problems might exist in Vietnam. He stated there was reason to question the wisdom of some of the earlier technical decisions on the standardization and acceptance test procedures. The first indication of a possible problem reportedly came from conversations with the rifle project manager.

Dr. Payne indicated in his memorandum that "at least two of the problems seem to be important enough to warrant further investigation and corrective action if they are verified. They are as follows: (a) the choice of ball powder in the 5.56 ammunition; (b) primer sensitivity."

As to the choice of ball powder, he stated that the decision did not derive from any evidence that increased effectiveness could be expected and that there was no record of subsequent engineering tests comparing ball powder with IMR.

Dr. Payne in his memorandum further stated:

The symptoms of trouble reported from the SAWS test are as follows: (a) the cyclic rate of the weapons is much higher (200 rounds per minute) than in acceptance test or previous engineering test; (b) excessive parts breakage; (c) excessive fouling leading to excessive failures after about 300 to 400 rounds.

He concluded by writing:

I think it is clear that if these faults are present, it is not only important to the SAWS program, it is quite probable that the same problems exist in Vietnam.

The adverse effect of the ball powder in the 5.56-mm ammunition was confirmed in a subsequent test conducted by Frankford Arsenal; however, no action was taken to recall any ammunition loaded with ball powder, or to remove it from the qualified list of ammunition as was done with IMR 4475 when it failed to meet the velocity/pressure specification.

Army witnesses before the subcommittee testified that there was no relationship between malfunction of the M-16 as experienced in Vietnam and the excessive fouling demonstrated in the SAWS program.

It is the opinion of the subcommittee that the question of excessive fouling being associated with excessive malfunctions of the rifle has not received an adequate test and evaluation. Until this theory is adequately proved or disproved, the subcommittee is convinced that there is a direct relationship between the two. Obviously, excessive fouling requires more intensive and more frequent cleaning.

One of the modifications proposed by the Army to reduce malfunctions is the chrome plating of the barrel chamber. This will simplify the cleaning of the chamber and reduce pitting within the chamber; however, it will have no effect on the carbon build-up on the working parts of the rifle caused by the fouling characteristics of ball powder.

In the final report on the Army Small Arms Weapons Systems study (SAWS study) dated August 30, 1966, the Army Test and Evaluation Command of Combat Developments Command concluded that, "The relatively low level of functional reliability of the XM16E1 rifle in these tests is not considered representative of the normal performance which can be expected from this weapon, which has been demonstrated in past tests, but is considered to indicate a need for improvement in quality control, in weapon manufacture, and for investigation of the effect of ammunition upon weapon functioning."¹⁹

Based upon the results of a field experiment, the U.S. Army Combat Development Company Experimentation Command concluded, among other things, that "The standard 5.56-mm. ammunition provided for the experiment is not satisfactory because of fouling characteristics, the pressure mismatch of propellants in the ball and tracer cartridges, and primer sensitivity." However, it was stated that these "ammunition deficiencies are judged readily correctable."

Malfunctions related to ammunition

As early as March 1964, the problem of excessive cyclic rates when using ball propellant was called to the attention of the Technical Coordinating Committee by the rifle contractor when he cited his experience on the acceptance tests when using both ball and IMR propellant. It was pointed out that of 10 weapons tested, six exceeded the upper limit of a cyclic rate test for acceptance when firing ball propellant, whereas one of 10 tested exceeded the cyclic rate when using IMR propellant. At that time, the contractor requested, and the Technical Coordinating Committee approved, a waiver of the upper cyclic rate limit for acceptance purposes of those rifles delivered in April. Subsequently, it was necessary to extend the waiver for the months of May, June, and July. After that time, the contractor used only IMR propellants for the cyclic rate test, thereby qualifying the rifles for delivery to the Army.

¹⁹ Emphasis added.

The relationship between high cyclic rates and ball propellant ammunition was again called to the attention of Army officials in June 1965 by Colt's and in November 1965 by a test report submitted by Colt's citing the exceedingly high cyclic rate when using ball propellant for test acceptance purposes. In view of their favorable experience in 1964 in obtaining a waiver in this area, Colt again suggested raising the upper cyclic rate limit by 150 rounds per minute to accommodate both IMR and ball propellant ammunition. Colt's test concluded that for weapons such as those used in their experiment, none are likely to fail with IMR, whereas more than one-half are likely to fail with ball ammunition. This report also pointed out that fatigue failures of the bolt are somewhat more frequent when the cyclic rate of fire is significantly increased.

Colt's reported there are also certain malfunctions which occur more frequently when the timing of the gun cycle is materially speeded up. Especially there is increased frequency of the failure of the bolt catch to arrest the bolt after firing the last round in a magazine.

This relationship of ball propellant ammunition and excessive cyclic rates and broken parts was also confirmed in the early reports from the test agencies participating in the SAWS study, in particular the reports from the Combat Developments Command Experimentation Center at Fort Ord, Calif. The relationship was further confirmed by tests conducted at Frankford Arsenal in December 1965²⁰ as well as later reports from Colt's in January and March of 1966.

Another cause of malfunctions was called to the Army's attention in the same March 1964 meeting of the Technical Coordinating Committee when it was reported that ammunition utilized in acceptance testing at Colt's had exhibited various degrees of fouling characteristics. It was stated that in certain lots several thousand rounds may be fired from weapons (without cleaning) without any evidence of malfunction due to fouling. In other lots, stoppages occurred due to fouling in as little as 500 to 600 rounds.

The subcommittee notes that at that point in time, March 1964, the ammunition specification failed to include restrictions against fouling caused by the ammunition. Subsequently the specification was amended to include a 1,000 round fouling test to be successfully conducted on each preproduction lot as a condition of acceptance. This requirement applies only to the preproduction lot as a condition of acceptance and not to follow-on production quantities. However, as pointed out to the subcommittee, unless close quality control is maintained in the loading of each lot of cartridges, the chemical composition and performance characteristics can differ. It is inconceivable that the Army would accept as many as 59 million cartridges on the basis of testing only one preproduction lot.

QUALITY ASSURANCE

Prior to the receipt by Colt's of the first Army contract on November 4, 1963, Colt's had no formal detailed quality assurance procedures for the inspection of AR-15 rifles, including those sold to the U.S.

²⁰ The test report was dated February 1966. It pointed out that the malfunction and stoppage rates per 1,000 rounds were 18.5 and 5.2, respectively, when firing ammunition loaded with ball propellant versus 3.2 and 0.75, respectively when firing ammunition loaded with IMR propellant.

Air Force. The Army contract, however, contained requirements for a quality assurance program which Colt's was required to submit to the Government for approval. Representatives of Springfield Armory, Boston Procurement District, and Army Weapons Command, assisted Colt's personnel in preparing a quality assurance program which the Army approved on February 7, 1964.

Reports prepared by Army Weapons Command personnel in connection with their periodic surveillance of Colt's quality assurance program indicate that during 1964 Colt's experienced certain difficulties in implementing the approved quality assurance program. These difficulties ranged from failing to coat all metallic surfaces with preservative oil after cleaning the rifle to an uneven flow of material, resulting in rush and jamups toward the end of the month in an effort to meet commitments. It wasn't until February 1965 that Colt's quality assurance program was concluded to be generally satisfactory in operation and conformance. During the balance of 1965 and through 1966, Colt's received satisfactory ratings from the Springfield Armory teams who periodically reviewed their quality assurance program.

Generally, the quality assurance procedures at Colt's now consist of both visual and functional examinations of all raw materials, purchased parts and parts manufactured by Colt's for the M-16 rifle as well as finished products, that is, rifles and spare parts. Visual examinations include the inspector's insuring that the proper type or quantity of gages are at each work station and insuring that the proper operation tags are attached to the various machines. Examples of functional examinations include the inspector's witnessing rifles fired for target and accuracy and the inspector's changing of parts in rifles to insure interchangeability.

At the request of the subcommittee, General Accounting Office representatives made a limited review of Colt's quality assurance program currently in effect and found no instances where the contractor was not properly following the approved program.

The Government supervisory inspector at Colt's plant, Mr. Christo W. Kantany, appeared as a witness before the subcommittee. Mr. Kantany testified that the current quality assurance procedures at Colt's production and assembly facilities are adequate. However, he recommended returning to the previous function firing test of 40 rounds, compared to the present practice of firing only 20 rounds.

Another suggestion made by Mr. Kantany was to take a large sample of production rifles, "say 500 to 1,000," and fire each of these weapons 200 to 300 rounds apiece. In this manner one can readily determine what the problems are with the M-16 rifle.

Mr. Kantany also testified that he did not receive any instructions from anyone to tighten inspection procedures when reports of excessive malfunctions were received from Vietnam. He took the initiative upon reading newspaper accounts of the problems in March or April, some 6 months or more after reports were submitted to the Army Materiel Command and the rifle project manager. Mr. Kantany tightened the inspection procedure on the chamber of the barrel. He testified that out of a 50-barrel sample, 12 were defective. This was said to be higher rejects than normally experienced under quality control standards.

Mr. Kantany is to be commended for taking the initiative in this vital area of responsibility.

With respect to the question of the possible connection between rifle malfunctions and proper lubrication, the subcommittee views with concern the following facts:

1. After months of unequivocally defending the authorized rifle and small arms lubricant (known as VV-L-800 or PL Special) being issued in Vietnam, the Army has acknowledged in its report dated June 1967, that a better lubricant for the difficult environmental conditions of Vietnam has existed in the inventory since 1959, and since late May has been rushing it out to the troops.

2. The special qualities of this purportedly superior lubricant (known as MIL-L-46000A) became known to the Army, according to its own account, as the result of tests designed specifically to weigh the claims of a commercial, molybdenum disulfide base lubricant (known as Dri-Slide), which has won considerable acclaim from many of the troops in Vietnam who have procured it by mail order at their own expense and inconvenience. Without such outside stimulus there is no indication as to when the Army would have reviewed the lubricating qualities of MIL-L-46000A and considered making it available for use in Vietnam.

3. As a further result of this special Army test it was discovered that the official rifle maintenance instructions were improper in that the lubricant was required to be sparingly applied to certain parts of the M-16; and revised instructions prescribing liberal lubrication have been issued as of June 2, 1967.

4. In 1966 the Marine Corps tested, approved, and procured approximately 100,000 units of Dri-Slide as a supplemental lubricant for use in Vietnam along with the authorized lubricant (VV-1-800). According to testimony before the subcommittee on May 16, Marine Corps spokesmen reported that the troop response to Dri-Slide was "very enthusiastic" and that they were in the process of reordering this type of lubricant. It was also stated that a test was being made of the new Army lubricant MIL-L-46000A. In a memorandum dated July 24, 1967, the Commandant of the Marine Corps announced, in releasing the final report of this test that:

a. Mil-L-46000A would replace VV-L-800 as the "standard general purpose lubricant for all small arms."

b. Contrary to the findings of the test and the recommendation of the testing facility, the supplemental lubricant (Dri-Slide) would not be retained in the supply system.

In testimony before the subcommittee on August 8-9, this test, which was identical in scope to the one conducted in 1966, was acknowledged by Marine Corps representatives to have shown that Dri-Slide was "significantly more effective" under dry, sandy conditions and "equally effective" as MIL-L-46000A on the M-16 and M-16A1 rifles under muddy water conditions. However, when questioned as to why the Marine Corps did not accept the results of its own test, the witness disclosed that certain test findings were subsequently rejected on the basis of a further analysis ordered by the Marine Corps. Upon request a copy of this analysis was submitted for the record and the document bears the date of June 30, 1967. Since the final test report dated July 24, 1967, contains no reference to such an analysis or any suggestion that the test was invalid in any way, the subcommittee can only conclude that it

was misled by the witness when told that further analysis had caused the Marine Corps to reject the results of its own test. To compound matters, this same Marine Corps analysis, it was learned after study, raised questions about the 1967 Army lubricant test as well.

Therefore, in view of the confused, uncoordinated, crisis-oriented, self-protective manner which has characterized all too much the handling of the matter of rifle lubrication, so vital to the welfare of the foot soldier in the field, the subcommittee recommends that:

The Secretary of Defense—

a. Authorize an independent research facility to conduct a thorough analysis of the tests procedures of the various services to ascertain their reliability; and to conduct such additional tests of such lubricants as are found necessary to clearly establish their effectiveness as lubricants under various conditions.

b. Initiate efforts to improve coordination among the services to insure an orderly, continuous research and development program in the field of weapons lubricants; and to report to the committee the steps he has undertaken to accomplish this.

M-16 TRAINING PUBLICATIONS

At the present time the two major publications providing training and maintenance instructions on the M-16 rifle are the Army field manual FM23-9, and a technical manual TM-9-1005-249-14. An examination of the manuals indicates unnecessary duplication on one hand, while providing a lack of information and instructions on another. For instance, the field manual fails to contain adequate instruction on stoppages and actions for correction. Also, certain training publications appear to provide misleading instructions in that the language tends to oversell the reliability of the rifle.

Examples of this language are as follows:

This weapon requires the least maintenance of any type weapon within the Army arsenal today.

This rifle will fire longer without cleaning or oiling than any other known rifle. An occasional cleaning will keep the weapon functioning indefinitely.

Working parts can be cleaned by wiping with a clean cloth.

The recent experience in Vietnam tends to refute the above statements. In fact, military personnel are now instructed to provide what some consider to be an excessive amount of care and cleaning of the weapon.

Consideration should be given to consolidating into one publication the field and technical manuals to provide consistency of information and a lack of duplication.

Training instructions at all levels should emphasize the proper care and cleaning of the rifle in view of the characteristics of the ammunition utilized.

FOREIGN SALES

Since the AR-15 rifle has been in production by Colt's Inc., approximately 55 foreign countries have procured or accepted small quantities for test and evaluation. Two exceptions from the standpoint of quantity are England and Singapore. In these two instances, England received 5,000 rifles in 1965 and Singapore is to receive 20,300 during 1967 and 1968.

In addition, the Army has supplied substantial quantities of M-16A1 rifles to our allies fighting in Southeast Asia.

The one sale causing the subcommittee to be greatly concerned was that of 20,300 rifles to Singapore. The concern was not one of fear that the weapons would fall into unfriendly hands or that the security forces of Singapore should not be equipped with a modern and efficient weapon, but whether or not the U.S. inventory of this weapon was sufficient to provide the quantities needed for our fighting forces in South Vietnam, including United States and allies. In addition there existed at the time of the approval of the Singapore sale an unfulfilled requirement for M-16 rifles for training of U.S. military personnel prior to their deployment to Southeast Asia and for equipping support units in Southeast Asia.

State Department witnesses admitted in testimony that someone "goofed" in failing to obtain proper approval from the Department of Defense prior to issuing the export license. Subsequent to that instance the coordinating instructions have been reemphasized and now require approval of the military department involved prior to the issuances of export license for weapons.

POSSIBLE CONFLICT OF INTEREST

Maj. Gen. Nelson M. Lynde, Jr., U.S. Army, retired, was commanding general of the Army Weapons Command from May 16, 1962, until February 29, 1964, the date of his retirement. From March 1963, at which time the Technical Coordinating Committee was established and Lt. Col. Harold W. Yount was designated rifle project manager under the Army Weapons Command which reported to the Army Material Command, General Lynde's Command was directly involved in the negotiations for procurement of the M-16 rifle. General Lynde testified that he was responsible for the development, procurement, and field service support of Army weapons.

As previously mentioned in the report, General Lynde on October 4, 1963, is recorded as approving the prices as negotiated and directed the preparation of approval of award for submission to higher authority.

On October 31, 1963, 4 days before the award of the initial letter contract for production of 104,000 rifles for the Army and the Air Force, General Lynde appointed his deputy, Brig. Gen. Roland B. Anderson, as the contracting officer on the one-time basis to permit the award of the contract to the Colt's Patent Firearms Manufacturing Co. He stated that his reason for the appointment was that he would be absent from the command at the time of the contract award.

General Lynde retired from the Army on March 1, 1964. Two days before his retirement he sought an opinion of the Army Adjutant General regarding an offer of employment from the Fairbanks Whitney Corp., the parent company to Colt's. He indicated in his letter to the Adjutant General that he was the head of the procurement activity as commanding general of the U.S. Army Weapons Command during the negotiation, evaluation, and recommendation for award and award of Contract DA-11-199-AMC-508 (Y). He also indicated that the "proposed employment does not contemplate, nor would I, of course, engage in any activity with regards to the M-16 rifle where the U.S. Government might be directly involved." He indicated further that the offer must be accepted on or before March 15, 1964.

The Adjutant General's letter of reply was dated March 5, 1964. It is as follows:

Your letter indicates that you will be employed by the Fairbanks Whitney Corporation as an executive consultant accountable to the president for professional and technical guidance to the Corporation and/or its subsidiaries, in planning for new products for the future and in evaluating current product or projects, particularly in the area of military weapons. It does not appear from the position description submitted with your letter that your duties will require you to sell any property or service to the United States. If these conclusions are correct, then your employment will not be contrary to any pertinent laws or regulations.

Since it appears that you were involved in munitions procurement activities while on active duty, you should bear in mind while carrying out the duties fixed by your private employment that you remain subject to the restrictions fixed by title 18, United State Code, section 207. Section 207 (a) permanently prohibits retired Regular Army officers from knowingly acting as agents or attorney for anyone other than the United States in connection with any proceeding, application, contract, request for a ruling, or other particular matter involving a specific party or parties, in which the United States is a party or has a direct and substantial interest, and in which they participated personally and substantially while on active duty. Section 207 (b) of the same title bars retired Regular Army officers, for one year after retirement from appearing personally as agent or attorney before any court or agency of the government for anyone other than the United States in connection with any proceedings, application, contract, or other particular matter involving a specific party or parties in which the United States is a party or directly and substantially interested, and which was under his official responsibility as an officer within one year prior to retirement.

You are advised that the foregoing is advisory only, as the interpretation and enforcement of Federal statutes are matters for final determination by the Department of Justice and the Federal Courts.

General Accounting Office personnel assisting the subcommittee in obtaining information on the M-16 procurement program were advised by Colt's officials that their records showed that General Lynde was hired as an executive consultant on August 1, 1964.

General Lynde testified before the subcommittee that he was employed by Fairbanks Whitney, now Colt Industries, Inc., on August 3, 1964, and since his employment he had refrained from association with the M-16.

The General Accounting Office inquiry also disclosed a letter dated October 26, 1964, signed by General Lynde, as a retired general, to the U.S. Army procurement district requesting copies of four classified documents including one entitled "Comparative Effectiveness Evaluation of the AR-15, M-14."

The records at Colt's also reveal General Lynde's name appearing on the distribution list for many intercompany memorandums involving the M-16.

Without passing judgment on the legality of General Lynde's activities since becoming associated with the company producing a rifle contracted for by his immediate command while he was on active duty, the subcommittee does seriously question the wisdom of such action in view of the suspicion aroused by this type of association. It is actions such as these that cause the American taxpayer to lose faith in the integrity of both military and civilian officials associated with the expenditure of millions of dollars yearly in the procurement of supplies and material to meet our military requirements.

Several discrepancies are noted between the testimony of General Lynde and the facts obtained by the subcommittee:

1. Chairman Ichord questioned General Lynde: "Did you approve the 1963 procurement contract of the M-16 rifles from Colt, Inc.?" His reply was that he "appointed Brig. Gen. Roland B. Anderson as a contracting officer on a one-time basis to permit the award of contract."

The record shows that General Lynde, as Commanding General of the Army Weapons Command, *approved the prices negotiated* and directed the preparation of approval of award for submission to higher authority. The mere fact that he did not sign the contract as contracting officer does not mean that he did not participate in the negotiations right up to the eve of contract award.

2. General Lynde testified and stated in his letter to the Adjutant General that he did not or would not engage in any activity with regard to the M-16 rifle where the U.S. Government would be directly involved, yet the record shows that on October 26, 1964, he requested from the U.S. Army a classified document which compared the effectiveness of the AR-15 with the M-14 rifle;

3. In spite of his assertion of no interest in the M-16 rifle activities, his name appears on distribution lists for intercompany memorandums involving the M-16 rifle; and

4. The delay of 5 months between his retirement from the Army and his employment by the M-16 rifle producer would appear not to constitute a sufficient cooling-off period in view of the fact that the employment offer was made before his date of retirement and, by his own admission, had to be accepted on or before March 15, 1964, 2 weeks after his retirement date.

ROYALTIES

In accordance with a license and technical assistance agreement dated January 7, 1959, Colt's acquired from Hiller Corp., Hagerstown, Md. (formerly Fairchild-Stratos Corp., and Fairchild Engineering & Airplane Corp.) the rights and licenses to make, to use and to sell the AR-15 rifle in the United States and elsewhere in the world. As a consideration for the rights and licenses Colt agreed to pay Fairchild certain royalties as provided for in the agreement and a lump sum payment of \$75,000. The agreement also committed Colt to the payment of royalties on all spare or replacement parts and components manufactured and sold by Colt.

Cooper-Macdonald, Inc., Baltimore, Md., an authorized representative of Colt for the sale of various Colt products throughout the world, was instrumental in consummating the agreement between Colt and Fairchild. For its efforts in securing this agreement, Cooper-Macdonald obtained a fixed sum of \$250,000 as a "finders fee" and a commission of 1 percent of the selling price of each rifle, spare parts, and accessories.

Colt, according to its various agreements with Fairchild, is obligated to pay royalties on the selling price of weapons (rifles) and spare parts sold for military and commercial use. The current agreement between Colt and Fairchild, dated April 1, 1963, grants Colt an exclusive right and license to make, use, and sell weapons (rifles) and spare parts in the United States territory and to sell such weapons and spare parts throughout the world. Included in the agreement is a provision which requires Colt to pay the following:

- (a) To Domestic Licensor:
 - (i) a royalty of four and one-half percent (4½%) of the Selling Price of Weapons and Spare Parts manufactured and Sold by Licensee in the United States Territory or as otherwise permitted by Section 3(a), for military use;
 - (ii) a royalty at the following percentages of the Selling Price of Weapons and Spare Parts manufactured and Sold by Licensee in the United States Territory or as otherwise permitted by Section 3(a) for Commercial Use during each calendar year:
 - Five percent (5%) of the first \$200,000 of sales of Weapons and Spare Parts;
 - Four and one-half percent (4½%) of any amount of such sales excess of \$200,000;
- (b) Only to Foreign Licensor:
 - (i) a royalty of four and one-half percent (4½%) of the Selling Price of Weapons and Spare Parts manufactured and sold by Licensee as permitted by Section 3(b), for Military Use or Commercial Use.

In the event a sublicense is granted by Colt the agreement subjects Colt under domestic patent rights to a royalty arrangement of not less than 3 percent of the selling price of weapons and spare parts for military use. On commercial sales the royalty payments decrease from a high of 5 percent to a low of 3 percent as sales increase. Any foreign sublicense granted by Colt requires royalty rates of not less than 4 percent of the selling price of weapons and spare parts.

During the period July 1960 through the first quarter 1967; Colt's royalty payments to Fairchild totaled \$2,628,283 based on military and commercial sales of rifles and parts. Of this amount, \$2,339,651 represented payments on military sales.

ACTIONS TAKEN SUBSEQUENT TO SUBCOMMITTEE'S INQUIRY

Marine Corps witnesses testified that subsequent to the subcommittee's visit to Vietnam, the Commanding General, III Marine Amphibious Force, established an orientation team for the M-16 rifle. The team visited every Marine unit explaining the problems experienced and the measures which must be taken to get the most out of the M-16 weapon. In a later submission of information for the record, the Marine Corps reported as follows:

In addition to the visit of the Orientation Team, the following actions have been taken since the subcommittee visit to Vietnam.

- a. Commanding General, III Marine Amphibious Force, has formed a contact team of M16A1 experts from the Force Logistic Command. This team has been tasked with the mission of visiting M16A1-using units and training similar teams. The Unit Teams, in turn, will conduct a technical inspection of each M16A1 rifle, provide instruction on care and cleaning, and supervise test firing of each weapon to insure proper weapon functioning. (Copy of message establishing and directing team activities is attached.)
- b. Interim instructions were promulgated on 4 August 1967 for the use of lube oil, semi-fluid MIL-L-46000A with the M16A1 rifle in lieu of lube oil general purpose (PL Special) and rifle grease (9150-754-0063). The interim instructions will be used pending receipt of III MAF of Marine Corps Supply instructions. (Copy of interim instruction attached.)
- c. Articles have been published in the June 1967, July 1967, and August 1967 "Tactical Trends and Training Tips" regarding care, cleaning, and use of the M16A1. The August 1967 article was printed to provide for removal from the publication and separate retention. (Copies attached.)
- d. A Force Bulletin on the M16A1 was promulgated on 16 June 1967. The bulletin contains special instructions for care, cleaning, and correction of common malfunctions of the M16A1. (Copy attached.)
- e. Copies of USARV pamphlet 750-5 of 14 December 1966 have been distributed to each Marine armed with the M16A1.

f. Copies of a pocket/wallet sized card with instructions regarding care and cleaning of the M16A1 are being provided for distribution to each Marine armed with the weapon.

On the problem of cleaning equipment, Chairman Ichord asked Brig. Gen. Gordon D. Gayle, Deputy Assistant Chief of Staff, G-3, Headquarters, U.S. Marine Corps, "What, if anything, after the committee visit, was done to assure that every man using the M-16 rifle has the necessary cleaning equipment, particularly a cleaning rod and chamber and bore brushes?"

The reply was that the Marines have instituted "Operation M-16" where cleaning equipment has been airlifted to our forces in Vietnam. Also, it is reported that accelerated procurement of additional quantities of cleaning equipment is underway to cope with the unexpected utilization of equipment being approximately three times the expected rate.

The actions taken by the Army are reported elsewhere in the report. The Deputy Secretary of Defense, the Honorable Paul Nitze, on July 31, 1967, issued a memorandum directing a technical evaluation and field survey of the performance of the M-16 rifle. The purpose of the survey and evaluation was stated to be "to determine whether any major deficiencies exist in the weapon, and, if so, to recommend corrective action."

To conduct the technical evaluation, the Director of Defense Research and Engineering, with the assistance of the Assistant Secretary of Defense (I. & L.) and the Assistant Secretaries for Research and Development of the military departments, was requested to compile and analyze existing data available in continental United States and determine the following:

1. How does the M-16 rifle perform under a variety of circumstances, i.e., environmental, level of training, modes of fire?
2. Considering its mode of employment, what should be the standards of performance and reliability for the M-16 rifle?
3. What have been the causes of malfunction in the M-16 rifle; what has been or is being done to improve the weapon's reliability; and what further can be done?

In addition, the Assistant Secretary of Defense (Administration) was requested to conduct a field survey of the M-16 rifle in South Vietnam. He was instructed to "ascertain the degree to which corrective actions to eliminate causes of M-16 malfunction have been implemented; and general performance and acceptability of the M-16 rifle in the field; and general performance and acceptability of the M-16 rifle under combat conditions."

A final report together with appropriate recommendations was requested to be submitted no later than October 15, 1967.

FINDINGS AND RECOMMENDATIONS

Based on our extensive review the subcommittee's findings and recommendations are as follows:

1. That both Army and Marine Corps personnel have experienced serious and excessive malfunctions with the M-16 rifle, the most serious being the failure to extract the spent cartridge.
2. That proper care and cleaning are of the utmost importance to the effective operation of the rifle.

3. That shortages of cleaning equipment, lack of proper training and instructions contributed to the excessive malfunction rate of the M-16 rifle in Vietnam.

4. That various levels of command in both the Army and the Marine Corps have been negligent in failing to provide proper supervision in the care and cleaning of the rifle, as well as failing to distribute cleaning material and written instructions.

5. That the past experience of the Army with the M-16 rifle in Vietnam was not properly called to the attention of the Marines when the weapon was issued to them in Vietnam.

6. That the major contributor to malfunctions experienced in Vietnam was ammunition loaded with ball propellant.

7. That the change from IMR extruded powder to ball propellant in 1964 for 5.56-mm. ammunition was not justified or supported by test data.

8. That the sole-source position enjoyed by Olin Mathieson on ball propellants for many years and their close relationship with the Army may have influenced the decisionmakers at Army Munitions Command, Army Weapons Command, and the Army Materiel Command. The House Armed Services Committee repeatedly has cautioned the military departments against sole-source procurements. *Therefore, it is recommended that the General Accounting Office conduct an audit and investigation of the contracts awarded to Olin Mathieson for ball propellant loaded in both 5.56-mm. and 7.62-mm. ammunition and the justification for sole-source procurement over the past 26 years.*

9. That a number of modifications to the M-16 rifle were made necessary only after ball propellant was adopted for 5.56-mm. ammunition.

10. That the AR-15/M-16 rifle as initially developed was an excellent and reliable weapon.

11. That certain modifications made to the rifle at the insistence of the Army were unnecessary and were not supported by test data.

12. That two of these modifications increased the unit cost of the rifle substantially and another decreased its performance characteristics. These modifications were the bolt closure device, chrome plating of the barrel chamber, and the change in barrel twist.

13. That corrective action on deficiencies reported and product improvement of the weapon have been unnecessarily delayed.

14. A sole source of production of both the ball propellant and the M-16 rifle have contributed to the delay in product improvement and the corrective action required.

15. That officials in the Department of the Army were aware of the adverse effect of ball propellant on the cyclic rate of the M-16 rifle as early as March 1964, when it was brought to the attention of the Technical Coordinating Committee, yet continued to accept delivery of additional thousands of rifles that were not subjected to acceptance or endurance tests using the ammunition of greatest density in the field and in the supply system (ball-propellant-loaded ammunition). Up to September 1966, about 99 million rounds of 5.56-mm. ammunition were consumed in Vietnam, of which 89 million rounds were loaded with ball propellant.

16. That the rifle project manager, the administrative contracting officer, the members of the Technical Coordinating Committee, and

others as high in authority as the Assistant Secretary of Defense for Installations and Logistics knowingly accepted M-16 rifles that would not pass the approved acceptance test. Colt's officials advised the Army that more than half of the rifles would not pass the acceptance test on cyclic rate if they were made to use both ball propellant and IMR extruded propellant in their testing procedure. Colt's was allowed to test using only IMR propellant at a time when the vast majority of ammunition in the field, including Vietnam, was loaded with ball propellant.

17. That the failure on the part of officials with authority in the Army to cause action to be taken to correct the deficiencies of the 5.56-mm. ammunition borders on criminal negligence.

18. That there still is no proof that the modifications proposed will eliminate the malfunctions experienced with the M-16 in Vietnam. *It is recommended that the Department of Defense direct and expedite a thorough and objective test by an independent organization of the weapon system consisting of the modified rifle and the ammunition in Vietnam, as well as both types of propellant currently being loaded in 5.56-mm. ammunition.*

19. That the fouling characteristics of ball propellant will require continued emphasis on proper care and cleaning of the M-16 rifle. Carbon deposit buildup will continue to pose a problem for the extractor, various parts of the bolt mechanism, bolt carrier key, the gas port, and possibly other areas in both the upper and lower receiver.

20. That there is a possible pressure mismatch between tracer and regular ball ammunition that could cause the rifle not to operate properly.

21. That there was a shortage of M-16 rifles for training purposes both in the United States and Vietnam at the time of the approval of the sale of 20,300 rifles to Singapore.

22. That there was a lack of proper coordination between the State and Defense Departments on the sale of the rifles to Singapore.

23. That no instructions regarding tightening of production quality controls were issued by the rifle project manager, Army Materiel Command, or anyone in high authority after continued reports of malfunctions were received from Vietnam.

The Government inspector at Colt's plant took the initiative only after reading newspaper reports of problems being experienced. These newspaper reports were not published until about 6 months after notices of excessive malfunctions were received by the rifle project manager and the Army Materiel Command.

The only inspection tightened as a result of these adverse reports was the one on barrel chambers. This tightened inspection revealed an excessive number failed to meet specifications. *It is difficult for the subcommittee to understand why quality controls were not tightened immediately upon receipt of adverse reports from the troops in Vietnam.*

24. That the bias and prejudices of individuals associated with Army commands or agencies responsible for development and testing of new weapons made it extremely difficult for higher authority to obtain objective information upon which decisions should have been made relative to the rifle program.

25. That the Army system of development, production, and introduction of a new weapon into the inventory should be thoroughly

reviewed to determine if the rifle program is typical of the manner in which the Army operates. The manner in which the Army rifle program has been managed is unbelievable. The existing command structure was either inadequate or inoperative. The division of responsibility makes it almost impossible to pinpoint responsibility when mistakes are made. There is substantial evidence of lack of activity on the part of responsible officials of highest authority even when the problems of the M-16 and its ammunition came to their attention. It appears that under the present system problems are too slowly recognized and reactions to problems are even slower.

The rifle project manager doesn't appear to have control over ammunition. Yet, the weapon system consists of both the rifle and ammunition. It is possible that internal politics and jealousies between the Army Weapons Command and the Army Munitions Command are roadblocks to the successful management of new weapons systems.

26. That it was at least unethical for Major General Lynde to accept employment with the producer of the M-16 rifle upon his retirement from the Army. General Lynde was commanding general of the Army Weapons Command throughout the negotiations for the first Army procurement of the M-16 rifle and in fact approved the terms of the contract negotiated by his subordinates.

27. That minimum effort was expended by the Army and the Department of Defense in attempting to acquire the production rights and technical data package for the purpose of establishing additional sources for production of the M-16 rifle.

Based on Army reports in 1962 and 1963, there was reasonable doubt that the 1963 buy was to be only a "one-time buy" for the Army. The 1966 analysis of the SAWS study and the rifle procurement plan proposed by the Army clearly indicated the need to acquire the rights and data package, yet the Army failed to complete negotiations of a contract until mid-1967. The 1965 procurement contract was amended in June 1966 to increase the quantity by an additional 300,000 rifles. The same amendment provided for negotiations to be completed on the terms for acquiring technical data and production rights not later than December 1, 1966. The negotiations were not completed until over 1 year later, June 30, 1967.

28. That both the Army and Colt's failed to negotiate in good faith in an attempt to comply with the terms of the 1965 production contract; i.e., come to terms on the rights and data package on or before December 1, 1966.

29. That this lack of action delayed the establishment of additional production sources by at least 7 months.

30. That based on information and records made available by the contractor and the Army, it appears that Colt's has enjoyed an excessive profit on M-16 production contracts to date.

Colt's has enjoyed negotiated fixed-price contracts on a 10 percent profit rate basis. Our review revealed profits of 19.6 percent for calendar year 1965; 16.8 percent for calendar year 1966; and 13.4 percent for the first 4 months of 1967. *It is recommended that the General Accounting Office conduct a complete audit of Colt's military contracts to determine actual profit rates experienced, the adequacy of their accounting system and whether provisions of Public Law 87-653 were circumvented.*

31. It is recommended that proper action be taken by the Secretary of Defense and the Secretary of the Army to insure that the design, contracting, procurement, manufacture, development, supply, and testing of future weapons not suffer the same fate.

The subcommittee recommends that the Secretary of Defense and the Secretary of the Army make adequate studies to determine if the abolishment by the Secretary of Defense of the Office of the Chief of Ordnance (which was accomplished along with the abolishment of the position of other chiefs of various Army services in 1962) could have been partly responsible for the failure of proper control and supervision in the matter of the M-16.

RICHARD H. ICHORD, *Chairman.*
SPEEDY O. LONG.
WILLIAM G. BRAY.

I have read the foregoing report and find myself in full accord with the views and recommendations of the subcommittee.

L. MENDEL RIVERS, *Chairman.*

○

REPORT ON THE M-16
RIFLE PROGRAM

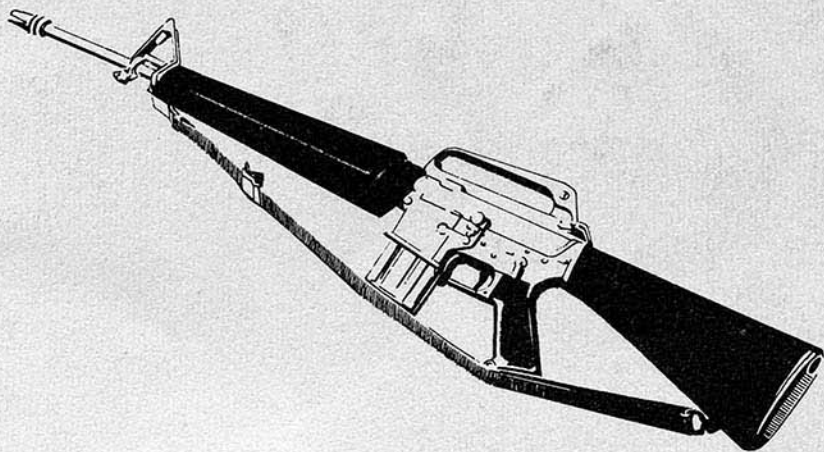

DEUTSCHLAND ORDNANCE CO.

P. O. BOX 801

SANTA CLARA, CALIFORNIA, U. S. A. 95052

Digitized by:

MARS TM-160

15 JANUARY 1968

REPORT ON THE M-16
RIFLE PROGRAM

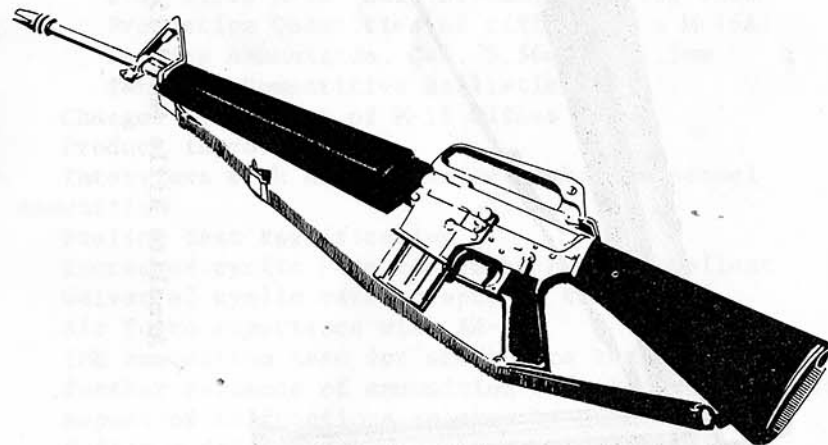

DEUTSCHLAND ORDNANCE CO.

P. O. BOX 801

SANTA CLARA, CALIFORNIA, U. S. A. 95052



ArmaLite Rifle Model 15, Caliber .223

	Page
Background of M-16 rifle	1
Historical background on Army rifles	1
Air Force procurement of AR-15 rifle	5
Test of AR-15 rifle in Vietnam by ARPA/OSD	5
Comparison of AR-15 & M-14 rifles by Comptroller, DOD	6
Question of objectivity of Army evaluation	9
Army procurement of AR-15 rifle	11
Fiscal year 1964 procurement	11
Modifications to the rifle	13
Second Army procurement of AR-15 rifle	19
Army small arms weapons system program (SAWS)	15
Sole source procurement of AR-15 rifle	17
Acquisition of rights and data	19
Excessive profits by Colt's	22
Establishment of a second source of production	22
Mobilization base for M-14 rifles	23
Vietnam investigation	23
Army problems with the M-16	23
Special Section	25
Photographs	25
U.S. Rifle M-16, Cal. 5.56mm, Interior View	29
Production Quantities of rifle M-16 & M-16A1	30
Service Ammunition, Cal. 5.56mm x 44.5mm	31
Table of Comparative Ballistics	32
Changes in support of M-16 rifles	33
Product improvement	33
Interviews with Army & Marine combat personnel	35
Ammunition	38
Fouling test specification	41
Increased cyclic rate caused by ball propellant	42
Waiver of cyclic rate acceptance test	42
Air Force experience with AR-15	43
IMR ammunition used for acceptance test	43
Further evidence of ammunition effect on cyclic rate	44
Report of malfunctions related to ammunition	45
Buffer modification	46
Ammunition deficiencies called to attention of DOD	46
Quality assurance program	48
Lubricants	50
M-16 training publications	51
Foreign sales	51
Possible conflict of interest	52
Royalties	54
Actions taken subsequent to subcommittee's inquiry	55
Findings and recommendations	56

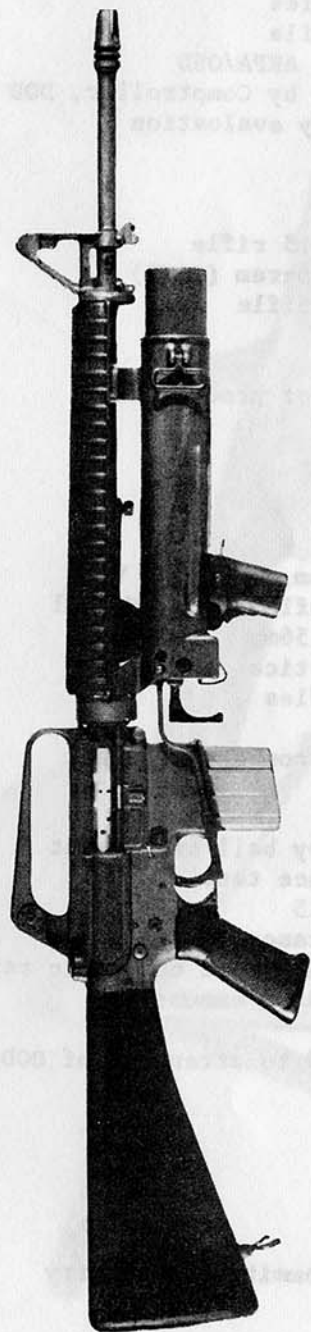

U.S. Rifle M16 with Grenade Launcher M148

REPORT OF THE SPECIAL SUBCOMMITTEE ON THE M-16 RIFLE PROGRAM

By letter dated May 3, 1967, a special subcommittee on the M-16 rifle was established by the Honorable L. Mendel Rivers, chairman of the House Committee on Armed Services. Members appointed to the subcommittee were: Mr. Richard Ichord, of Missouri, chairman; Mr. Speedy O. Long, of Louisiana; and Mr. William G. Bray, of Indiana. The subcommittee was directed to make inquiry into the development, history, distribution, sale, and adequacy of the present M-16 rifle. Also, the subcommittee was directed to determine the advisability of relying on a sole source for production of the rifle and any military proposals for a followon weapon.

Extensive hearings were conducted by the subcommittee between May 15 and August 22, 1967. Many contacts or inquiries were received by members of the subcommittee. In addition, field investigations were conducted at Fort Benning, Ga.; Camp Pendleton and Hamilton Air Force Base, Calif.; several military hospitals; and throughout South Vietnam. Also, visits were made to the producer's plant at Hartford, Conn., and to the facilities of two former M-14 rifle producers, Olin-Mathieson and Harrington & Richardson. An interim report was submitted to the chairman of the Armed Services Committee on June 30, 1967, shortly after the subcommittee returned from Vietnam.

BACKGROUND

The M-16 rifle was designed in 1957 by Mr. Eugene M. Stoner, chief engineer of Armalite, a division of Fairchild Engine and Airplane Corp. The M-16, originally known as the AR-15 was subsequently identified as the XM16E1 and the M-16A. Regardless of designation, all models are almost identical. The major difference is a manual assist bolt closure device added to the Army and Marine version first known as the XM16E1 and classified "standard" by the Army in February 1967 as the M-16A1. The original AR-15 adopted by the Air Force is now known as the M-16 rifle. The rifle is a 5.56-millimeter, magazine-fed, gas-operated, air-cooled, shoulder weapon. It is a lightweight, high-velocity system designed to fire a .223-caliber cartridge.

HISTORICAL BACKGROUND ON ARMY RIFLES

The following historical background of the Army rifle program is based on an Army study, dated January 9, 1963,¹ and other information contained in the subcommittee files or the hearing record:

¹ "Rifle Evaluation," a study made under monitorship, Office, Deputy Chief of Staff for Military Operations, Headquarters, Department of the Army.

Since the introduction of the .30 caliber small arms round in 1903, the U.S. Army has consistently required that the rifle and automatic small arms (BAR and machine guns) fire the same cartridge. The .30 caliber cartridge was considered the optimum size for general purpose use for these reasons:

(1) The bullet was large enough to facilitate development of special purpose rounds, i.e., ball, tracer, incendiary, and armor piercing.

(2) The round was the most powerful that could be tolerated in a shoulder weapon and still adequately meet the extended range performance required in the automatic weapon.

Satisfactory performance of the .30 caliber family of weapons in World War I led to its general acceptance as a reliable and efficient system. The Ballistics Research Laboratory, Aberdeen, Maryland, as early as 1928 recommended investigation of a small caliber, high-velocity system (caliber .276 and .25 and smaller) because of the promised savings in weight and possible increase in lethality. However, the Army, at that time, preferred to increase the effectiveness of the infantry soldier by developing a semi-automatic rifle for the proven .30 caliber cartridge and maintain the desirable feature of ammunition interchangeability with the automatic weapons already in the Army inventory.

The semi-automatic M-1 (Garand) rifle was the outgrowth of this development and served very effectively during World War II and Korea. However, in 1945 the Army recognized that the M-1 rifle was heavier than desired and began to investigate systems which would be lighter and capable of full automatic fire. By again specifying the use of the full size, .30 caliber cartridge, the possibility of designing a truly lightweight weapon was severely handicapped. Several models were built, but none was adopted.

In 1954 the adoption of the NATO 7.62mm round required reorientation of the U.S. rifle program to accommodate the shorter length of the NATO round. The T44E4 was specifically designed for the NATO round but incorporated the best features of the developmental weapons preceding it. In June 1957, the T44E4 was classified standard as the M-14 rifle although it was recognized that it provided only a minor technical improvement over the M-1.² The primary advantages of its adoption were its ability to replace the M-1, the BAR and the carbine while simultaneously fulfilling the NATO agreement with respect to standardization of small arms ammunition.

(The subcommittee notes that the Army requirements development plan 1969-72 provides the following guidance to the Army staff on the development of new material: "Marginal improvements in existing weapons and equipment are not desired. As a general order of magnitude, an improvement of less than 25 percent is considered marginal. R. & D. projects which do not promise an improvement of at least 25 percent should either be reoriented or terminated.")

In 1958 the AR-15 caliber .223 rifle was first tested by the Army at Aberdeen Proving Ground, Fort Benning, Ga., and Fort Greely, Alaska. Although the concept and the rifle reportedly were well received by CONARC, there were reservations as to the suitability of the caliber .223 round as a military cartridge.

The advantages and disadvantages of the AR-15 system led to divergent positions within the Army as to its suitability. A board of general officers, headed by a General Powell, was convened late in 1958 to review the entire rifle program and, if possible, reconcile the conflicting opinions. The Powell Board liked the small-caliber high-velocity concept but allegedly recommended no further consideration be given to the caliber .223 round. They further recommended "that the M-14 be retained for the automatic rifle role but that development of an AR-15-type weapon chambered for a caliber .258 round be expedited to replace the M-14 in the rifle role."³ The caliber .258 reportedly was the Powell Board's estimate of the optimum small-caliber round.

² Emphasis added.

³ "Rifle Evaluation," a study made under monitorship, Office, Deputy Chief of Staff for Military Operations, Headquarters, Department of the Army.

In late 1958, Headquarters, Continental Army Command (CONARC) directed the Army Combat Development Experimentation Center, Fort Ord, Calif., to conduct a lightweight, high-velocity rifle experiment. The stated purpose of the experiment was "(a) to compare the relative effectiveness of variously organized rifle squads armed with M-14 rifles; and (b) to determine the impact of the lightweight, high-velocity rifles on squad organization, techniques, and logistics."

The report states that the experiment "was an exhaustive comparison of target hit performance, in simulated attack and defense situations, of squads armed with the U.S. rifle M-14, caliber .30 (7.62mm-NATO); the Armalite AR-15 rifle, caliber .222; and the Winchester lightweight military rifle, caliber .224." The experiment was conducted by the U.S. Army Combat Development Experimentation Center during the period December 1, 1958-March 22, 1959.

The final report, dated May 30, 1959, contained the following conclusions:

a. With a total combat weight per man equivalent to that planned for riflemen armed with the M-14, a squad consisting of from 5 to 7 men armed with the LWHVR system would have better hit distribution and greater hit capability than the present eleven-man M-14 squad. Furthermore, employment of the smaller squad armed with the lightweight rifle system would permit more economical use of manpower on the battlefield.

b. By opinion poll, the experimentation troops favor the LWHVR system, as represented by the Armalite, because of its demonstrated characteristics of lightness in weight, reliability, balance and grip, and freedom from recoil and climb on full automatic (ease of firing).

c. The Winchester rifle is comparable to the M-14 in hit probability.

d. The Armalite rifle is comparable to the M-14 in reliability.

e. Both candidate weapons of the lightweight high-velocity rifle system are superior to the M-14 in hit distribution.

f. The presently developed representatives of the lightweight high-velocity rifle system require the following improvements before further experimentation with them should be considered:

(1) Winchester Lightweight Military Rifle, caliber .224, must be redesigned so that the component parts, including the bolt assembly, are strengthened and made more resistant to breakage, to bring the functional reliability equal to or above that of the M-14.

(2) Armalite, AR-15, caliber .222, must be modified and improved, with special emphasis on the sights, to bring the hit capability equal to or above that of the M-14.

g. Automatic fire with an LWHV rifle appears to have exceptional tactical value when the rifle is fired in short bursts (three to six rounds) on full automatic.

h. The attributes demonstrated by the prototype weapons of the lightweight high-velocity category indicate an overall combat potential superior to that of the M-14. Such advantages include: inherent characteristics of lightness in weight of arms and ammunition, ease of handling, superior full automatic firing capability, accuracy of the Winchester, and functional reliability of the Armalite.

The report recommended:

a. That emphasis be placed on the development of a lightweight high-velocity rifle combining the accuracy characteristics of the Winchester with the reliability characteristics of the Armalite, and not exceeding the weapon/ammunition weight of either.

b. That such a lightweight high-velocity rifle be developed with a view toward early replacement of current rifles.

c. That concurrent with the adoption of a lightweight high-velocity rifle, serious consideration be given to reduction in the size of the present squad with resultant great saving in manpower.

In January 1959, before the above rifle experiment was completed, the Army Chief of Staff, allegedly after analysis of all available facts

including the recommendations of the earlier mentioned Powell Board, decided that the M-14 production would remain as scheduled; that the 7.62-millimeter round would be continued unless a new concept offered a very significant improvement; and that any product improvement would be kept in the 7.62-millimeter caliber.

As a result of this decision, the Army abandoned attempts to develop a conventional small caliber high-velocity system and concentrated its efforts on an unconventional system which allegedly promised significant advantages in combat effectiveness. This effort led to the special-purpose individual weapon (SPIW) program which it is claimed will produce a significantly improved weapons system in the future.

The SPIW concept is intended to combine and improve the point target capability as represented by the M-14 rifle and the area target capability as represented by the M-79 grenade launcher in one weapon. By firing multiple projectiles simultaneously, or almost simultaneously, in an optimum dispersion pattern, the hit probability or the point target component on man-sized targets is predicted to be at least double that of conventional rifle systems. The area target component will be at least as good as the M-79 grenade launcher.

The Army anticipated the availability of the SPIW for late fiscal year 1965. However, the weapon encountered development problems and still remains a research and development system not expected to be completed for several more years, if then.

The Air Force continued to test and evaluate the AR-15 rifle with very favorable results and on May 22, 1961, validated the quantitative requirement to procure the AR-15 rifle and ammunition. In January 1962 the AR-15 was classified as a "standard" weapon for the Air Force inventory.

The Air Force was advised by Colt that the .223 caliber 55 grain, metal-jacketed bullet manufactured by Remington Arms, Inc., was developed in cooperation with Armalite for use in the AR-15 rifle. The Remington cartridge was given a status classification of "development" on December 19, 1961. A test was conducted at Hill Air Force Base, Utah, on February 20, 1962, to determine if the Remington round was of sufficient quality to justify complete testing and development for USAF use. The conclusions of the test were:

Based on the results of this test conducted at OOMA (Ogden Air Materiel Area) and the requirements for the New Basic Weapon as outlined by USAF, the Cartridge, Caliber .223 manufactured by Remington Arms Inc. and used in this test appears to have the qualities desired in this weapon system.

Killing and wounding power of the cartridge is excellent at ranges of at least 500 yards. The cartridges weigh approximately one-half as much as a .30-06 cartridge.

The bullet, having a high velocity, travels a flatter trajectory than slower bullets, giving less vertical error with a fixed iron sight.

It was recommended that a large sample of the ammunition tested be acquired to complete the testing required before adopting the round as a U.S. Air Force item. The Remington specifications on this ammunition called for single base powder suitable to ballistic requirements of this cartridge with maximum average pressure of 52,000 pounds per square inch and an average velocity of 3,245 plus or minus 40 feet per second.

On May 23, 1962, the Air Force awarded a contract to Colt Patent Firearms Manufacturing Co. (Colt's Inc.) for 8,500 rifles, spare parts, and 8,500,000 rounds of ammunition. Colt subcontracted manufacture of the ammunition to Remington Arms Co., Inc., with inspection and acceptance of ammunition to be based on independent laboratory certification that ammunition conforms to established commercial standards. The Remington specification was the same as that tested 3 months earlier by the Air Force at Hill Air Force Base, Utah.

The Air Force change of ammunition from the single base extruded powder to the double base ball powder occurred on the subsequent procurement of ammunition in October 1963. This will be discussed in a separate section of the report under "Ammunition."

TEST OF AR-15 RIFLE IN VIETNAM BY ARPA/OSD

The problem of selecting the most suitable basic weapon for the Vietnamese soldier is complicated by his small stature and light weight. The average soldier stands 5 feet tall and weighs 90 pounds. In 1961 the principal U.S. weapons issued to Vietnamese troops included the U.S. rifle, caliber .30 M-1; Browning automatic rifle (BAR), caliber .30; the Thompson submachinegun, caliber .45; and the U.S. carbine, caliber .30, M-1.

Reportedly because of its availability and the results of extensive studies and previous testing by military agencies, the Colt Armalite AR-15 rifle was selected in July 1961 as the most suitable weapon for initial tests to determine if it was compatible with the small stature, body configuration and light weight of the Vietnamese soldier and to evaluate the weapon under actual combat condition in South Vietnam.

Based upon favorable observations of the AR-15 by both U.S. advisers and Republic of Vietnam Armed Forces (RVNAF) commanders following limited firing demonstrations conducted in Vietnam during August 1961, weapons were requested in numbers sufficient to conduct a full-scale combat evaluation of the AR-15 by selected units of the RVNAF. In December 1961, the Secretary of Defense approved the procurement of 1,000 AR-15 rifles, necessary ammunition, spare parts and accessories for evaluation.

The Advanced Research Projects Agency of the Office of the Secretary of Defense negotiated a contract with the firm of Cooper-Macdonald, Inc., Baltimore, Md., for procurement and air shipment of all material. The first shipment was received on January 27, 1962. Operational evaluation and testing began on February 1 and terminated on July 15, 1962. It is reported that the ammunition used was produced by Remington under normal commercial specifications.

To accomplish the stated purpose of this test, it was divided into two parts. One part was a combat evaluation of the AR-15 in which the weapons were issued to specially selected ARVN units for use in their operations against the Vietcong. The other part of the test consisted of a comparison between the AR-15 rifle and the M-2 carbine. The test report contains the following:

RESULTS, COMBAT EVALUATION

Summary.—The Vietnamese Unit Commanders and U.S. Advisors who participated in the evaluation consider the AR-15 Rifle to be a more desirable weapon

for use in Vietnam than the M-1 Rifle, BAR, Thompson Sub-machine, and M-1 Carbine for the following reasons:

(a) It is easier to train the Vietnamese troops to use the AR-15 than the M-1 Rifle, BAR, M-1 Carbine, or the submachine gun.

(b) The AR-15's physical characteristics are well-suited to the small stature of the Vietnamese soldier.

(c) It is easier to maintain the AR-15 both in the field and in garrison than the M-1 Rifle, BAR, Sub-machine gun, or the M-1 Carbine.

(d) The ruggedness and durability of the AR-15 are comparable to that of the M-1 Rifle and superior to that of the BAR, Sub-machine gun, and M-1 Carbine.

(e) The AR-15 imposes less logistical burden than any of the four principal weapons presently being used by Vietnamese Forces.

(f) The AR-15 is tactically more versatile than any present weapon being used by Vietnamese Forces.

(g) In Semi-automatic fire, the accuracy of the AR-15 is considered comparable to that of the M-1 Rifle, and superior to that of the M-1 Carbine.

(h) In automatic fire, the accuracy of the AR-15 is considered comparable to the Browning Automatic Rifle and superior to the Sub-machine Gun.

The report states that the lethality of the AR-15 and its reliability record were particularly impressive. No parts breakage was encountered while firing approximately 80,000 rounds during the comparison test. Only two parts were issued to replace breakage for the entire 1,000 weapons tested.

The report further stated that no deficiencies in the weapon requiring correction prior to adoption were found during the test in Vietnam, although two minor changes are recommended for product improvement. These were: (1) Roughen the surface of the upper hand guard to make it easier to grip when hands are sweaty; and (2) add an additional section and provide a T-shaped handle to the cleaning rod.

As a result of the ARPA test, the commander of the U.S. Military Advisory Command in Vietnam (COMUSMACV), General Harkins, on October 19, 1962, requested a substantial quantity of AR-15 rifles and ammunition to equip certain South Vietnamese Army units. This request was supported by the Department of the Army but opposed by the commander in chief, Pacific Forces (CINCPAC), even though he recognized the AR-15 as an excellent weapon. CINCPAC's objection was based on the cost of introducing this weapon into the military assistance program and the requirement for other projects with higher priority which were bidding for limited funds.

On March 14, 1963, the Joint Chiefs of Staff concurred in the CINCPAC position stating that the AR-15 rifle should not be programmed under the military assistance program for Southeast Asia because of increased cost, logistic complications, the inferior nature of enemy weapons and worldwide MAP implications. On March 25, 1963, the Secretary of Defense approved the JCS recommendation.

COMPARISON OF AR-15 AND M-14 RIFLES BY COMPTROLLER, DEPARTMENT OF DEFENSE

On September 27, 1962, a report was submitted to the Secretary of Defense by the Office of the Comptroller, Department of Defense. This report was stated to be a cost-effectiveness comparison of the M-14 rifle then being procured by the U.S. Army, with the AR-15 then being procured by the U.S. Air Force.

The comparison was relative to general combat use of the AR-15 by Army units in both normal and special combat situations. The study concluded that the AR-15 was decidedly superior in many of the factors considered and in none of them was the M-14 superior. It further concluded that in combat the AR-15 was the superior weapon. Other conclusions contained in the report were:

1. The study concluded that "taking into account the greater lethality of the AR-15 rifle and improvements in accuracy and rate of fire in this weapon since 1959, in overall squad kill potential the AR-15 rifle is up to 5 times as effective as the M-14 rifle."

2. In automatic fire capability and tactical flexibility the AR-15 rifle is markedly superior to the M-14 rifle.

3. The AR-15 rifle can replace, with gains in each case, all standard shoulder-fired weapons.

4. The M-14 rifle is marginal, at best, as a replacement for the BAR, is somewhat less satisfactory as a semi-automatic rifle than the M-1 rifle, and is not capable of replacing the sub-machine gun or the M-79 grenade launcher.

5. The AR-15 rifle can be produced with less difficulty, to a higher quality, and at a lower cost than the M-14 rifle.

6. In reliability, durability, ruggedness, performance under adverse conditions, and ease of maintenance the AR-15 is a significant improvement over any of the standard weapons including the M-14 rifle. The M-14 rifle is weak in the sum of these characteristics. Earlier reports that the AR-15 rifle is deficient in performance under Arctic conditions or with rain in the barrel are incorrect.

7. In lethality the AR-15 rifle bullet is markedly superior to that of the M-14 rifle or any other known bullet.

8. It is significantly easier to train the soldier with the AR-15 than with the M-14 rifle.

9. Three times as much ammunition can be carried on the individual soldier within the standard weapon-and-ammunition load, or alternately the soldier's combat load can be reduced by 40%, with the AR-15 rifle as compared with the M-14.

10. In accuracy, at all ranges of U.S. Army interest for rifles, the AR-15 rifle is at least as effective as the M-14 rifle, and the AR-15 rifle ammunition has further growth potential in this respect.

11. In meeting the U.S. Army penetration requirement the M-14 and AR-15 rifles are essentially equal.

12. In the ability of the bullet to penetrate brush the AR-15 and M-14 rifles are approximately equal and both are adequate.

The subcommittee notes that the ARPA test and the evaluation of the AR-15 rifle by the Defense Comptroller were based on the performance of the rifle using a single-base extruded powder (IMR).

After receiving the report from the office of his Comptroller, the Secretary of Defense directed a memorandum on October 12, 1962, to the Secretary of the Army stating that he had seen certain evidence which appeared to indicate that the M-14 was definitely inferior in firepower and combat effectiveness to the assault rifle of the Soviets and their satellite forces worldwide. Also, that the AR-15 was markedly superior to the M-14 rifle in every respect of importance to military operations. The Secretary of Defense requested the view of the Department of the Army on the relative effectiveness of the M-14, the AR-15, and the Soviet rifle (AK-47).

In response to Secretary McNamara's memorandum, the Secretary of the Army directed an "impartial and objective evaluation of the relative effectiveness of the three weapons to include appropriate comparison tests." These tests and evaluations were conducted on an Army-wide basis, with the exception of the Pacific Command. The Combat Developments Command conducted the tactical evaluation and troop testing. The Army Materiel Command conducted technical

evaluation and testing of the rifles. The report was submitted on January 9, 1963.⁴ It indicated that "throughout the numerous reports available on this subject it is apparent that opinions and positions are many and varied as are their origins. It appears that the divergencies encountered are due to the extreme personal nature of a hand-held weapon. Personal likes and dislikes on intimate or personal implications are comparable to the variance in preference for rifles."⁵

The report stated that the study was "based on recently compiled inputs that stressed impartiality and objectivity and on past evaluations that are deemed to have been objective."

The Army evaluation went far beyond the request of the Secretary of Defense. It considered the weapons and ammunition; logistical implications; doctrine and concepts; political implications (international and domestic); Soviet small-arms characteristics, doctrine, concept of development trends; technical aspects of the three weapons and the special-purpose individual weapon (SPIW) and the impact on standardization.

The Army evaluation concluded:

An analysis of all data submitted indicated that, of the weapons tested, only the M-14 is acceptable for general use in the U.S. Army. The AR-15, although lighter than the M-14, is not considered suitable as a replacement weapon because: it is less reliable; it has poor pointing and night firing characteristics; its penetration is marginally satisfactory; and its adoption would violate the NATO standardization agreements.

The Army study recommended "that the M-14 be retained as the standard U.S. Army rifle until the SPIW can be developed on an expedited basis." At this point in time the target date for initial procurement of the SPIW, under an accelerated research and development program, was January 1, 1965.

The Army rifle evaluation considered three courses of action as alternatives to the then existing program. Course of action A would continue M-14 rifle production until a radically improved individual weapon could be procured, such as the SPIW or its equal. Course of action B was to terminate production of the M-14 rifle at the end of the fiscal year 1963 procurement, to procure a military version of the AR-15 to complete the inventory objective as rapidly as possible, and to reorient the research and development small arms program to provide a weapon meeting or surpassing SPIW characteristics in a future time frame. Course of action C was to continue procurement of the M-14 rifle and procure, in fiscal year 1964, the military version of the AR-15 to equip in priority, air assault units, airborne units and Special Forces, and to continue with SPIW under normal research and development program with procurement commencing in fiscal year 1967.

Course of Action A was recommended in the Army evaluation report submitted January 9, 1963. The commanding general, U.S. Army Combat Development Command (the command responsible for summarizing the results of troop tests in Alaska, the Canal Zone, West Germany, Fort Carson, Colo., and Fort Hood, Tex.) recommended continued use of the M-14 by the U.S. Army force in Europe and equipping all units earmarked for deployment to Europe with the M-14 except airborne

⁴ "Rifle Evaluation," a comparative evaluation of U.S. Army rifle 7.62 millimeter, M-14; ArmaLite rifle caliber .223, AR-15; Soviet assault rifle AK-47.

⁵ The committee takes note also of the "NIH" (not invented here) attitude.

and Special Forces units. He further recommended equipping all air assault, airborne, and Special Forces units with the AR-15 "after the deficiencies in reliability and night-firing capabilities are corrected."

The Army Materiel Command (the command responsible for summarizing the results of tests conducted by the Army Infantry Board (Fort Benning, Ga.), Arctic Test Board (Fort Greely, Alaska), Ballistics Research Laboratory and Development and Proof Services at Aberdeen Proving Grounds, Md.) concluded, "based on assumption that the two major deficiencies of firing in the rain and in cold dense air are shown to be acceptable, easily correctible, or nonexistent, that the AR-15 rifle would be preferable to the M-14 for worldwide use under the assumption that this would be the initial introduction of a weapon into an army." This conclusion was said to be based primarily on the fact that the AR-15 offers a substantial weight reduction without sacrifice of essential performance characteristics.

The Army Materiel Command recommended that the AR-15 not be adopted as an across-the-board replacement for the M-14. It recommended "that the AR-15 be procured for Special Forces units and airborne forces to exploit the weight advantage and gain experience with the system, if tests in progress prove it to be acceptable." Continued development of the SPIW program on an expedited basis to insure earliest possible availability was also recommended.

Question of objectivity of Army evaluation

Apparently there was reason to question the objectivity of the Army-wide test and evaluation of the weapons considered. In December 1962 the Secretary of the Army directed that the Department of the Army Inspector General investigate the circumstances surrounding the November-December 1962 evaluation and tests to ascertain their validity.

The purpose of the Inspector General investigation was set forth in a directive from the Secretary of the Army dated December 21, 1962,⁶ which stated:

In October 1962, I directed that there be conducted an impartial and objective evaluation of the relative effectiveness of the M-14, the AR-15, and the Soviet assault rifle to include appropriate comparison tests.

As a matter of the highest priority I desire you to conduct a thorough investigation into all of the circumstances surrounding the conduct and evaluation of such tests, including, but not limited to—

- a. Instructions (formal, informal, official, or unofficial) which may have been issued with respect to such tests at any echelon within the Department of the Army;
- b. The conditions under which such tests have been or are being carried out;
- c. The conduct of the tests themselves;
- d. The methods by which the results of such tests are recorded;
- e. The methods by which such tests are evaluated; and
- f. The attitude towards such tests by any personnel in any way connected with their conduct or evaluation.

The purpose of your investigation will be to ascertain whether there is any ground upon which the thoroughness, accuracy or objectivity of such tests, or of the conclusions based on such tests, can be questioned.

The investigation revealed that (not verbatim)—

a. An informal planning conference concerned with conduct of a comparative evaluation of the AR-15 and the M-14 rifles was held in Headquarters, U.S.

⁶ "Summary of Facts Pertaining to Investigation Concerning Comparative Evaluation of AR-15, M-14, and AK-47 Rifles" submitted by the Department of the Army, Sept. 15, 1967.

Army Materiel Command on 22 October 1962, with representatives from the following agencies: Headquarters, U.S. Army Materiel Command; Ballistic Research Laboratories, Aberdeen Proving Ground; Headquarters, U.S. Army Test and Evaluation Command; Development and Proof Services, Aberdeen Proving Ground; and the U.S. Army Infantry Board. The point was made during the discussion of the tests to be conducted and the agencies responsible for their conduct that those phases of previous tests which had reflected adversely on the AR-15 would be retested.⁷ The representative of the U.S. Army Infantry Board, in his memorandum for the record of the meeting, included the statement, "The U.S. Army Infantry Board will conduct only those tests that will reflect adversely on the AR-15 rifle plus other tests that may be considered appropriate * * *." Other written records of the meeting did not confirm the implication contained in the statement. All persons attending the meeting were interrogated and denied under oath that the implication conveyed by the statement was expressed at the meeting. The Army Colonel responsible explained that the statement from his memorandum for record was not a reflection of what he intended to say and could only have resulted through administrative error.

b. After test plans had been approved and tests were under way at Development and Proof Services (D&PS), Aberdeen Proving Ground, an officer from the Office of the Chief of Research and Development telephoned USATEC and suggested that the AR-15 be subjected to a specific form of rain test * * *. The AR-15 was subjected to the test, failed it, and this fact was noted in the D&PS test report. The M-14 was not subjected concurrently to this same test * * *.

c. During the conduct of the lethality tests at the Ballistics Research Laboratory, the M-14 rifle being tested gave indications of being inaccurate. The test weapon was replaced by another model of the M-14 for the continuance of the test.

d. M-14 rifles provided for the conduct of the test at Aberdeen Proving Ground were specially selected and showed closer than normal tolerances * * *.

e. M-14 ammunition used for the initial stages of the lethality tests at BRL (Aberdeen) was more accurate than an average lot of M-14 ammunition. (The handpicked ammunition was apparently "matchgrade").⁸

f. Personnel selected for firing the AR-15 were less familiar with their weapon than those firing the M-14, thus providing a handicap to the personnel with the AR-15.

g. The wooden stock and forearm of the M-14's subjected to the rain test at Aberdeen became swollen and discolored, a fact which was not recorded in the test results.

h. A separate summary report, which forwarded an evaluation of the test reports of subordinate agencies, indicated that wording used in interpreting tests did not appear to be as favorable to the AR-15 as test results indicated.

i. The analysis, conclusions, and recommendations of the Army Infantry Board test report indicated bias or prejudice against the AR-15 and in favor of the M-14.

j. The test report of the Arctic Test Board indicated some irregularities.

The report of investigation submitted by the Inspector General concluded that—

a. Instructions governing the tests, conditions under which the tests were run, conduct of the tests themselves and the methods of recording the test data were fair, impartial, objective and nonprejudicial.

b. Methods of evaluating the test data, as pertains to analytical processes involved and treatment of certain test results at the U.S. Army Infantry School (USAIS) and the U.S. Army Infantry Board (USAIB), were subjective and tended to favor the M-14 (USAIB).

c. Reporting of the test results, as pertains to presentation of the data, mixing personal observations with the analysis and the tone of the verbiage of the report at USAIS and USAIB, was subjective and tended to favor the M-14.

d. Attitudes of certain personnel at USAIS and USAIB were favorable to the M-14 to a degree that these attitudes may have caused subjective treatment of tests results in analysis and reporting.

⁷ Emphasis added.

⁸ Committee observation.

Shortly after completion of the evaluation of the Inspector General's investigation and the Army-wide test and evaluation of the M-14 versus the AR-15 and the AK-47, the decision was made to procure 85,000 AR-15 rifles to equip Airborne, Assault, and Special Forces units. Since the Air Force was also procuring the AR-15 at this time, the Secretary of Defense designated the Army as the Defense agent for all users of the rifle and ammunition. The Air Force contract negotiations for its fiscal year 1963 buy were at an advanced stage, so they were allowed to continue. However, beginning with the fiscal year 1964 buy, the Army was designated as the procuring agency for all services.

In a memorandum to the three service Secretaries, dated March 11, 1963, Secretary McNamara instructed: "so that beginning with the fiscal year 1964 procurement only one rifle, rather than separate service versions, is produced and that it is produced with minimum delay, modifications of the weapon and its ammunition are to be concurred in by all four services. Only such modifications as are absolutely necessary should be made."

In an effort to insure this objective, a Technical Coordinating Committee was established with representation from each military service. A desire was stated to formalize AR-15 rifle technical matters at technical committee meetings to be held probably on a monthly basis or more frequently, if required. The AR-15 rifle project manager was designated as Chairman of the Committee.

Fiscal year 1964 procurement

On April 5, 1963, the Secretary of the Army submitted a memorandum to the Secretary of Defense outlining the Army's plans for standardization and procurement of the AR-15 rifle and ammunition. The Army stated the plan was based "on the assumption that requirements for the weapon will be approximately 104,000 in fiscal year 1964 (85,000 Army; 19,000 Air Force) and that subsequent fiscal year's requirements will primarily be limited to 33,500 rifles in fiscal year 1965 for the Air Force. The fiscal year 1965 procurement will complete the total known Air Force requirements of 80,000." The Army memorandum stated that General Harkins' (COMUSMACV) request for 20,000 AR-15 rifles for Vietnamese units was not considered in view of the unfavorable decision of the Joint Chiefs of Staff.

The Army memorandum of April 5, 1963, stated that consideration was given to the comparative costs of sole source versus competitive procurement in developing the procurement plan. The comparison indicated that sole-source procurement was expected to result in the lowest cost, earlier production, with fewer administrative, legal, and employment problems.

It was estimated that production of the 104,000 rifles under the sole-source procurement plan could be accomplished within 29 months after initiation of the program whereas competitive procurement would require 33 months to complete deliveries. The unit cost of the rifle under the sole-source program was expected to be \$125.44 compared to a competitive procurement cost of \$138.74.

The memorandum also included changes to the then current AR-15 rifle which were considered absolutely essential. Agreement of all

services on these changes was expected provided it would not result in excessive increase in cost, degradation of performance, or delay in production. The modifications or changes listed were as follows:

- (1) Design a manual bolt closure device,
- (2) Redesign of magazine,
- (3) Modification of the chamber throat to assist extraction of entire cartridge upon clearing weapon.

It was said that these modifications were interrelated and could not be separated.

Other modifications listed and the associated problems were:

- (4) Eliminate slope at the rear right ramp to improve pointing-night-firing characteristics,
- (5) Determine desirable rifle twist to improve stability of round.

The last problem cited was a dimensional incompatibility of ammunition with the rifle chamber. It was proposed to modify the chamber and consider current ammunition configuration as standard. If, after the chamber was modified, the ballistics of the ammunition round were not satisfactory, consideration should be given to modifying the ammunition.

The memorandum also stated that it was planned to procure the .223-caliber ammunition for the AR-15 competitively, soliciting proposals from all commercial sources. Military standards specifications were being developed at this time for the caliber .223 ammunition. These specifications were to assure high-quality ammunition being procured by the services in fiscal year 1963, as well as 1964.

In closing his memorandum the Secretary of the Army stated:

In view of the current limited follow-on requirements for the AR-15 rifle and ammunition, it is considered that an adequate production base will be established. Colt Patent Firearms Company is expected to have established by about 1 July 1963, as a result of the fiscal year 1963 Air Force procurement, a multi-shift capacity of 5,000 rifles per month.

The Army rifle production base plan was reviewed by the Secretary of Defense who, in a memorandum dated June 27, 1963, stated:

My conclusions are that the plan is sound; however, some elements of the Army cost estimates are too high, and the lead times for the rifle and ammunition are unnecessarily long as is the time required for completion of deliveries of the rifle. I also conclude from this review that most of the modifications proposed in the plan are not essential or have already been accomplished.

Secretary McNamara approved the plan with certain provisions and modifications. One of the provisions was as follows:

*To exploit the advantages of this commercial development, the modifications and changes necessary to place the weapons system in development should be accomplished by request to the manufacturer concerned in consultation with the weapons designer.**

According to testimony and other information received by the subcommittee, this provision calling for consultation with the weapon designer on modifications and changes was not followed by the Army or whenever the designer was consulted it was after the fact and the decisions had been made and actions already taken. For example, the subcommittee received evidence to the effect that Mr. Frank Vee, a Department of Defense representative on the Technical Coordinating Committee, solicited the weapon designer's opinion about the decision

* Emphasis added.

to authorize WC-846 (ball propellant) for use in 5.56 ammunition. The weapon designer reportedly advised against implementing the decision. The fact of such a conversation was not refuted. Mr. Vee, when queried about the conversation, testified as follows at pages 4668, 4669, 4670, and 4671 of the hearing record.

Mr. VEE. . . . I cannot positively state that I can recall that we discussed the ammunition or the propellants in the ammunition; but I won't say I didn't discuss it. . . .

Mr. ICHORD. 1964 or 1965, along about that time did you have a conversation with him in which you solicited his opinion on the use of the ball propellant in your ammunition?

Mr. VEE. I don't remember that directly, sir. If he had a recorder—if we had a recorder, then I could be positively sure. I am not doubting it; I just can't prove it now.

Mr. ICHORD. . . . Did you not say to him during one of the meetings that the Army wanted to have everything, in ball propellant, that they could, in small arms?

Mr. VEE. Well, I won't deny it. I don't remember.

Mr. ICHORD. . . . So, obviously you talked about two things at that meeting—primer sensitivity, and also the powder. They are two very closely related subjects are they not?

Mr. VEE. Like I say, I am not denying we didn't discuss it. I can't be positive. I know that to be the only time—that the big depth on the private meeting was on sensitivity. That was the important problem.

On November 4, 1963, the Army awarded a letter contract to Colt Patent Firearms Co. (now known as Colt's, Inc.) for 104,000 AR-15 rifles. Of these, 19,000 were for the Air Force and 85,000 were for the Army.

Modifications to the rifle

Prior to the award of the first production contract by the Army, two major modifications were made to the rifle. The first and most expensive was the addition of the manual assist bolt-closure device. This modification was made at the insistence of the Army and over the objection of the Air Force and Marine Corps. The Air Force position on the manual closing device was as follows:

1. The Air Force does not consider a manual bolt closing device to be an essential part of the AR-15 rifle for the following reasons:

a. The design of this weapon has eliminated all mechanical linkage that was subject to binding during adverse operating conditions. Without the mechanical linkage, the requirement for the manual closing device is eliminated.

b. During more than 3 years of testing and operation of the AR-15 rifle under all types of conditions the Air Force has no record of malfunctions that could have been corrected by use of a manual bolt device.

c. The ARIA tests in South Vietnam did not reveal any requirement for the manual bolt closing device.

d. The recent Marine Corps tests have not indicated any requirement for the manual bolt closing device.

e. The 1958-1960 Army tests of the AR-15 did not reveal a requirement for the manual bolt closing device. The Infantry Board discussed this item during their initial tests, but concluded that there was no justifiable reason for the manual closing device.

f. The Air Force has discussed this matter with the designer of the weapon. The designer reported that he had considered this but did not find it necessary with the free floating bolt.

2. Modification of the AR-15 rifle to incorporate the manual bolt closing feature is considered to be undesirable for several reasons.

a. The modification will probably add weight to the weapon.

b. It will undesirably complicate the mechanism.

c. It will probably add additional parts to the weapon.

d. It will probably increase the cost of the weapon.

e. It will possibly introduce other malfunctions into the operation of the weapon.

f. Designs conceived to date are unproven and may introduce a personnel hazard if the components should malfunction. As designed a malfunction could result in the charging handle being driven to the rear into the face of the shooter.

g. Attempting to incorporate a design change of such magnitude into the weapon will probably delay procurement of the weapon if proper preproduction testing is to be accomplished.

3. During operation of the AR-15 rifle and other hand-held weapons, it has been found that it is not advisable to attempt to manually force the bolt of a weapon closed when a malfunction occurs. Forcing the bolt closed, driving live ammunition into the chamber not only aggravates the malfunction, but is also a dangerous practice. The recommended procedure is to clear the round by pulling the bolt to the rear for recycle. The U.S. Army Training Manuals for both the M-1 and M-14 rifles do not recommend manually forcing the bolt closed during a malfunction but rather specify that the bolt should be pulled to the rear to eject the bad round.

4. In view of the above and the fact that the Air Force will have 27,500 rifles in the inventory without this feature, it is not considered justifiable to include the manual bolt closing feature in the AR-15 rifle.

Both the Navy and the Marine Corps considered the modification to be nonessential. The manufacturer (Colt) took the original position that the manual bolt closure device was not necessary in view of the weapon's reliability. The rifle project manager, Col. Harold W. Yount, admitted in testimony that the modification was not supported by test results but was dictated or directed to be incorporated by "higher authority" in the Department of the Army.

Despite the lack of service agreement and adequate justification, the bolt closure modification was approved by the Secretary of Defense and incorporated into the production rifles to be delivered to the Army. This modification increased the unit cost of the Army rifles by \$4.53 and over the life of the production contracts will cost the taxpayers millions of dollars.

In discussing the bolt closure modification during the subcommittee's hearings the following testimony was received (page 4701 of hearings):

Mr. MORGAN. Was this modification justified on the basis of tests conducted?

Colonel YOUNT. I was unable to justify it on the basis of prior tests.

Mr. ICHORD. You state, Colonel Yount, you weren't able to justify it on the basis of tests. What were you able to justify it on?

Colonel YOUNT. On the basis of direction.

Mr. ICHORD. Where did that direction come from?

Colonel YOUNT. Well, as many decisions which were made on this rifle, this decision emanated from the Department of the Army staff, sir. It was further coordinated with the Department of Defense, and Secretary McNamara personally approved it.

The second major modification changed the barrel twist from a ratio of 1-in-14 to 1-in-12 inches. This change allegedly was made to improve the bullet stability in extremely cold temperatures but it reduced the lethality of the bullet as much as 40 percent according to information provided by witnesses appearing before the subcommittee.¹⁰ The subcommittee notes that the Army now is testing a barrel with a 1-in-14-inch twist again. The subcommittee questions the validity of a re-

¹⁰ Memorandum for the Under Secretary of the Army dated Feb. 10, 1967. Subject "Modifications to the M-16" signed by Wilbur B. Payne, Chief, Office of Operations Research.

quirement for a rifle to meet performance characteristics at minus 65° temperatures that are identical to the performance at a temperature of 125°.

Recently the Army amended the production contract to provide 2,000 rifle barrels containing a 1-in-14-inch twist for further test and evaluation. The subcommittee recommends that this test and evaluation be expedited and conducted in an objective fashion. If it is determined that this barrel twist ratio restores the bullet lethality of the M-16 to that demonstrated in the 1962 ARPA test conducted in Vietnam, an accelerated retrofit program should be initiated immediately.

At the time that Secretary McNamara approved the Army decision to procure the first 85,000 rifles, February 1963, it is reported that he instructed deferral of any further procurement of M-14 rifles. Subsequently, in December 1963 the Army advised the Senate Armed Services Committee that there would be no further procurement of the M-14 rifle. In view of this announced decision by the Army, it is difficult for the subcommittee to understand why little effort was made on the first procurement to obtain reproduction rights and technical data to enable competitive procurement on future requirements.

If the M-14 was not to be procured and the SPIW was not anticipated to be available for several years under the most optimistic expectations, what did the Army propose to procure to meet its operational requirements?

The subject of acquisition of the rights and data package will be discussed in greater detail later in the report.

ARMY SMALL ARMS WEAPONS SYSTEM PROGRAM (SAWS)

In December 1964, the Acting Chief of Staff, U.S. Army, directed a letter to the Commanding General, U.S. Army Combat Developments Command, requesting a comprehensive review and evaluation of small arms weapons systems in being or under development and feasible for adoption within the time frame 1967-80. The study was to determine whether any small arms weapons system or systems provide a degree of superiority over current small arms weapons systems sufficient to warrant acquisition by the U.S. Army and to determine the specific impacts of adoption of individual candidate weapons systems. The commands and agencies having a major area of responsibility in the preparation of supporting study material were:

- (1) U.S. Army Europe, Pacific, Alaska and Southern Commands,
- (2) U.S. Army Continental Army Command,
- (3) U.S. Army Materiel Command,
- (4) Combat Developments Command Experimentation Command, and
- (5) Combined Arms Research Office.

The study submitted on August 30, 1966, was "based upon information gathered and analyses performed primarily by the USACDC, Command Developments Command Infantry Agency under the pro-ponency of the USACDC, Command Developments Command Combat Arms Group."¹¹ The conclusions and recommendations of the

¹¹ U.S. Army Combat Developments Command, Army Small Arms Weapons Systems Study (SAWS).

study submitted were stated to be those of the Commanding General, U.S. Army Combat Developments Command.

The study outlined five alternative courses of action based on the results of the review and evaluation. These ranged from a recommended procurement of no additional rifles or automatic rifles beyond those XM16E1 rifles currently on order until SPIW becomes available to a course of action recommending the procurement of over 1 million XM16E1 rifles as replacement for current M-1 and M-14 rifles.

The SAWS study with its recommendations was reviewed and analyzed by the Army staff and on December 17, 1966, the Secretary of the Army submitted a memorandum to the Secretary of Defense outlining the objectives for the Army rifle program recommended by the Chief of Staff. These were:

- a. Rifle procurement in the foreseeable future should be limited to the XM16E1 rifle.
- b. Steps should be taken to permit early replacement of the caliber .30 rifles (M-1 and BAR) in the Army's inventory with the XM16E1 rifle.
- c. Rifle procurement planning over the long term should be based on the replacement of the M-14 rifle with the XM16E1.
- d. An additional production source for the XM16E1 rifle should be provided in the FY 68 budget.
- e. An active and broadened research and development program should be continued to bring about further major improvements in the Army's small arms."

The memorandum cited actions taken to attain the five objectives outlined and requested approval of the Secretary of Defense.

The Army Secretary's memorandum stated:

Significant findings of our view of the SAWS study include the following:

- a. The XM16E1 rifle is generally superior for Army combat use.
- b. The current SPIW program is unlikely to result in a satisfactory competitive weapon as early as previously forecast.
- c. Based on our experimental results, it is likely that some minor changes in the M-16 system are justified. These include use of a different powder grain in the cartridge and a change in the barrel twist.

By memorandum dated January 14, 1967, the Deputy Secretary of Defense approved for planning purposes objectives *a*, *d*, and *e*; however, approval was withheld on objectives *b* and *c* pending the following additional information:

1. A comprehensive cost/effectiveness evaluation of a one-rifle weapon system versus the present three system family and a mixed M-16/M-14 family which phases out the M-1. The study should explicitly treat the logistic implications of going from a three to a two and then to a one-rifle family, and the marginal benefits and marginal costs of a rifle modernization program which envision replacement of serviceable assets.
2. Your replacement and distribution schedule.
3. NATO implications of your proposed program.
4. Details of proposed changes in the M-16 system with a concurrence of the M-16/XM16E1 Technical Coordinating Committee, to include the effects on the manufacturing process and the availability of production facilities to provide a different powder grain.

Testimony before the subcommittee by Dr. Robert A. Brooks, Assistant Secretary of the Army (p. 4718) indicated that the decision was made last December (1966) to replace the .30-caliber rifles in the Army inventory with the M-16. The subcommittee questions the accuracy of Dr. Brooks' testimony in the light of Secretary Vance's memorandum dated January 14, 1967, which requested information by August 1, 1967, on items 1, 2, and 3 above, and by May 1, 1967, on item 4 above on which a decision would be based.

Apparently, the decision was made to replace the .30-caliber weapons in the Army inventory with the .223-caliber M-16 rifle. However, that decision and the question of ultimately replacing the M-14 rifle with the M-16 is not documented by testimony received or information furnished to the subcommittee.

SOLE SOURCE PROCUREMENT OF AR-15

The first major procurement of the AR-15 rifle was made in May 1962, by the Air Force for a total quantity of 8,500 rifles and spare parts and ammunition. This procurement of the AR-15 by the Air Force was to equip guard and security forces. Later, in October 1962, the Army procured a small quantity of 338 rifles for test and evaluation purposes.

The Air Force procured an additional 19,000 AR-15 rifles and spare parts in April 1963. This quantity was increased by the letter contract dated November 4, 1963, by an additional quantity of 104,000 rifles of which 85,000 were procured for the Army.

The 1963 decision by the Army to procure the AR-15 was authorized to equip airborne, assault and the Special Forces. This allegedly was then intended as a one-time-only procurement. A direct bearing on the Army's decision to order the AR-15 was the Secretary of Defense's disapproval of the Army's request to continue to procure the M-14 to replace all of the M-1's.

Prior to the negotiations for the fiscal year 1964 buy, the Army decided to include in its request for quotation (RFQ) a provision to obtain a complete technical data package including manufacturing rights for the AR-15 rifle. The justification for this action was to obtain competitive procurement on the follow-on buy of AR-15's and spare parts, and also to eliminate the high royalty of 15 percent paid for repair parts.

On September 3, 1963, Colt's responded to the RFQ dated August 3, 1963, and rejected the Army's request for quotation on the procurement of the technical data package and the manufacturing rights for the AR-15. Colt's letter stated:

Should the sum total of requirements for this rifle exceed 500,000 units, we will at that time consider licensing other sources of production and providing manufacturing know-how to them."

Colt's also stated that it did not intend to propose as a part of or in conjunction with the present procurement of 104,000 rifles to sell or license all or any portion of its proprietary rights to the U.S. Government.

The nature of this response was unquestionably a direct refusal by Colt's in light of the fact that up to that time only about 28,000 AR-15's had been sold to the U.S. Government and the RFQ contemplated an additional procurement of approximately 104,000 rifles and repair parts. Subsequently, Colt's clarified its position on this point on September 30, 1963, when it advised the Army that they had not meant to imply that Colt's would never consider such a sale of licensing, but as previously stated, "Colt's will consider licensing other sources of production and providing manufacturing know-how to them at such time as the total requirements for this rifle shall exceed 500,000 units."

¹² Emphasis added.

A meeting was held in the Office of the Assistant Secretary of the Army Ignatius on October 4, 1963, to discuss Colt's refusal to negotiate with the Army for the proprietary rights to manufacture the AR-15 for the fiscal year 1964 procurement. A memorandum for the record on the meeting, signed by Lt. Col. Arthur G. Moors, indicated that the request to attempt to procure these rights stemmed from the Assistant Secretary's impression that Department of Defense instructions called for competitive procurement. Further discussion ensued on this point and the memorandum shows as follows:

It was pointed out that the Secretary of Defense had approved the procurement plan for sole-source procurement of the rifles and competitive procurement of the ammunition subsequent to this letter. Secretary Ignatius then stated he fully understood why it would be difficult to negotiate with Colt for proprietary rights on such a small quantity of rifles. After some discussion of the problem and further review of the background, Secretary Ignatius stated it was his opinion we should amend the RFQ to delete the requirement regarding "Technical Data Package" for the fiscal year 1964 procurement and that negotiations should be continued with Colt after the award to obtain proprietary rights in the event of a possible future requirement. . . .

The meeting resulted in the Assistant Secretary's decision to "amend the RFQ for this buy to delete the requirement (for proprietary rights of manufacture) and to continue to negotiate after award in the event of a new requirement in the future."

The Commanding General, Army Weapons Command, Maj. Gen. Nelson M. Lynde, Jr., when notified of the Assistant Secretary's decision on October 4, 1963, stated "he thought we were in a position where it would be very difficult to negotiate the rights necessary for competitive procurement in the future, but apparently the decision has been made."

An undated "résumé of award" on the procurement of the 104,000 rifles from Colt's, prepared by J. C. Linnberg, Chief, Procurement Division, Headquarters, U.S. Army Weapons Command, stated that "on 4 October 1963, a briefing was presented to Major General Lynde covering the results of the negotiations held with Colt's. *The General approved the prices as negotiated and directed the preparation of the approval of award for submission to higher authority.*"¹³

It is obvious to the subcommittee that the Government never fully recovered from the Army's failure to push through an agreement to obtain the rights in 1963 at the time of the first large military procurement of the AR-15. Unquestionably, the Government was in its best bargaining position at that time and lost the advantage. Available information indicated that there appeared to be no particular urgency to this procurement; it was considered to be a one-time buy, even though at least two Army studies indicated a possible requirement of well over 500,000 AR-15 rifles during the next 5 years. The rifle was procured by the Army as experimental; the proponents for and defenders of the M-14 rifle were opposed to the small caliber weapon; and the contractor had no real customer for its product other than the U.S. Government.

Armed with information available only to the Army, it seems to the subcommittee, therefore, that the military was in a favored position to not only negotiate a binding agreement for the rights in the event that a follow-on requirement developed for the weapon, but also that a reasonable price for the rights could have been negotiated.

Over 2 years elapsed before another significant order for the AR-15 was placed by the Army. On December 7, 1965, Colt's was awarded a letter contract for 100,000 additional rifles—68,000 for the Army and 32,000 for the Marine Corps. The requirement for additional rifles allegedly generated from a Defense decision to equip U.S. troops, and our South Vietnam and Korean allies with this rifle. According to the Army, with U.S. buildup of combat troops and the escalation of the war in South Vietnam, the need for additional rifle procurement became apparent. General Westmoreland, the U.S. commander in Vietnam, also on December 6, 1965, formally requested that U.S. free world and RVNAF ground combat troops be supplied with the M-16 to replace semiautomatic weapons on a phased and selective basis determined by unit mission.

ACQUISITION OF RIGHTS AND DATA

In the interim 2-year period between the first large buy of the M-16 rifle in 1963 and the December 1965 order for 100,000 rifles, the Army had not purchased or reached an agreement to purchase the manufacturing rights for the rifle from Colt's. As a result, since Colt's exclusively owned the proprietary rights, the Army was placed in a position of dealing with another sole-source buy of the M-16 with the disadvantage of paying higher prices than if competition existed and, more importantly, of not filling the requirement of maintaining the security of the procurement base.

The Assistant Secretary of the Army's decision to delete from the 1963 buy the requirement to negotiate for the rights also included the requirement to continue to negotiate for the rights in the event of a new requirement in the future. The Army continued its efforts on an intermittent basis to acquire the rights from Colt's. However, these efforts were primarily informal discussions with the result that verbal offers only were elicited from Colt's as to the terms under which the U.S. Government could obtain a complete technical data package and a manufacturing license covering the M-16 rifle.

The most attractive of these offers was made in October 1964 when four separate verbal proposals were outlined by Colt's as follows:

Proposal No. 1 would establish a price of \$5,400,000.00 for the tech data package on which Colt could give the government a \$10.00 credit on each gun already delivered and to be delivered under existing contracts. This cost is in addition to a 5% royalty. Counting the number of rifles already delivered and to be delivered under present contract this would amount to a credit of \$1,600,000.00 leaving a balance of \$3,800,000.00 to be paid. The tech data package would be delivered on request at any time providing the unpaid balance was made up. Credit would also be given for spare part purchases. This proposal would cover the M-16 rifle, the M16E1 and the two shot burst control, but would not include any technical data for the blank ammunition, grenade launcher or grenade.

Proposal No. 2 provides for an immediate delivery of the tech data package upon a cash payment of \$3,600,000.00 plus a 7½% royalty. In this proposal and Proposal No. 1 no mention was made as to the length of time the royalty payment would continue.

Proposal No. 3 called for a firm commitment of 400,000 guns plus 5% royalty.

Proposal No. 4 called for a cash payment of \$2,500,000.00 plus a firm commitment for 200,000 guns and 50% of all future procurement in addition to a 4% royalty.

¹³ Emphasis added.

The most favorable offer-proposal, No. 1, when interpreted meant that if the Department of Defense would agree to buy 540,000 rifles, the only cost to the Government would have been the 5-percent royalty. At that time, the Army stated the offer was unattractive because there were no indications that Defense would require 540,000 or more rifles in the future. It is interesting to note, however, that this decision again conflicts with a 1962 Army study which for planning purposes considered that the AR-15 would be procured in quantity through fiscal year 1968. Also, the January 9, 1963, Rifle Evaluation Report of the Department of the Army considered a course of action which would have required the procurement of 800,000 AR-15 rifles through fiscal year 1968. Subsequently, in June 1965 when the Army opened the prior discussions relating to the acquisition of the rights and attempted to secure reaffirmation of this offer, Colt presented a different proposal.

This reluctance by Colt's in establishing firm terms for the acquisition of the rights is exceeded only by the Army's failure to formalize its position and negotiate seriously for the rights. The Army's vacillation in this matter is indefensible commencing with the stretching out of the acquisition of the rights over a considerable period of time, the informality of its actions, the indecision involved, and the delays of one type or another.

It is noteworthy to mention that after a 2-year period of simply discussing the acquisition of Colt's proprietary interests in the AR-15, the Army in its December 1965 buy for 100,000 units accepted Colt's argument, rather meekly it seems, that negotiations for the rights would be quite protracted and would certainly delay delivery of the rifles. As a result, the Army because of the stated urgency for the rifle due to Vietnam requirements decided to award the contract without including a provision in the contract binding Colt to negotiate for the rights. Subsequently, on June 17, 1966, the date of definitization of the letter contract, the Army's perseverance finally showed concrete results as a provision was incorporated into the contract whereby both the Army and Colt's agreed to negotiate in good faith so that the Government could obtain an irrevocable, nonexclusive license to manufacture, or cause to be manufactured, Colt's AR-15 rifles. The provision also stated that the negotiations for such rights and for the technical data package were to be completed on or before December 1, 1966. This, then, was the first time a formal commitment was obtained by the Army to negotiate for the rights in a serious manner. However, the subcommittee notes that this target date was missed by 7 months.

It is inconceivable that the search for the "right terms" under which the Army would consider acquiring the rights for the AR-15 rifle could have continued for so many years without bringing the contractor to the negotiation table in a formal manner, particularly in view of the continued congressional interest in the rights for the purpose of establishing a second production source since 1963, and the innumerable times that various congressional Members of both bodies had inquired into this matter. Time and time again, Defense witnesses testified that they understood the Government's policy. They also testified in a manner indicating that *active* negotiations were taking place on the acquisition of the rights when in fact very little was being done.

For instance, supplemental information submitted to support the February 21, 1966, testimony of Lt. Gen. W. W. Dick, Jr., Army Chief of Research and Development, before the House Armed Services Committee indicated that "the Army has submitted a proposal to Colt's to obtain the production rights in order that Colt's will not be the sole-source producer in the future" (p. 8363, Posture hearings). Also, Secretary McNamara advised the Congress less than 3 weeks later when he testified to the committee (p. 7572, 1966 Posture hearings):

... As far as the M-16 is concerned, Mr. Chairman, I believe I am correct in saying that we are already discussing the possibility of a second source, and I think I am correct in saying Colt has not made it at all difficult for us to obtain a license.

Yet, the records made available to the subcommittee during our investigation reveal that no formal contact between the military and Colt's apparently had been made on this subject for the previous 9 months, June 9, 1965, to March 9, 1966. In fact, it appears that after a conference on June 9, 1965, between Mr. Paul A. Benke, president of Colt's, and Mr. Kendall M. Barnes, General Counsel of the Army Materiel Command, the next contact on the subject of production rights was not until April 13, 1966. On that date a letter was sent by Mr. Barnes to Mr. Benke with a draft of a proposed license agreement, which was not accepted by Colt's.

It wasn't until June 19, 1966, that the Army converted the letter contract of December 6, 1965, into a definitive contract. This was done as a modification to the original letter contract and increased the quantity of rifles on contract from 100,000 to 403,905. The definitive contract also contained a section headed "Negotiation for Government Acquisition of Technical Data Package and License To Manufacture." This section clearly stated that "Negotiations for such rights and for the technical data package are to be completed on or before December 1, 1966."

It is a matter of history now that the Army finally purchased the rights on June 30, 1967. As suspected under the terms of the agreement with Colt's, the Government will pay handsomely for the rights. The basic terms commit the Government to pay:

- (a) \$1,500,000 in cash;
- (b) A royalty of 5½ percent of the selling price to the Government on all weapons and repair parts sold to the Government by sources other than Colt's;¹⁴ and
- (c) The Government agreed to contract with Colt's (on a sole-source basis) for delivery of 27,500 weapons per month each month through April 1968, and each month for 24 months thereafter except July, for which only 13,750 are to be delivered.

This agreement clearly guarantees the procurement of an additional 632,500 rifles from Colt's through April 1970.

There is no question that Colt's dictated the terms and the Government could either accept those terms or continue the risk of depending on only one producer which could be critical for a major weapon in the event of a production stoppage or slowdown of work effort. Such a work stoppage occurred at the Colt plant almost immediately after the signing of the contract.

¹⁴ Even though Colt's pays only 3-percent royalty on sublicenses.

The Secretary of the Army testified before the House Armed Services Committee in April 1967, in answer to a question on the status of licensing a second source to produce the M-16, that "It has been a tough negotiation." This testimony of Secretary Resor differs from that of Secretary McNamara which was mentioned earlier.

Under the various Air Force and Army procurement contracts for M-16 rifles and the recent agreement relating to production rights, Colt's has received orders for delivery of over 1,400,000 rifles plus repair parts. Colt's production capability has increased from the 5,000 rifles per month objective under the first Army contract of November 1963 to a present capacity of over 27,500 per month.

EXCESSIVE PROFITS BY COLT'S

At the request of the subcommittee, the General Accounting Office conducted an examination of the limited records made available by Colt's to determine profit rates experienced on M-16 contracts.

A 10-percent profit rate was negotiated on all production contracts. The records and information made available by Colt's indicate that profits before taxes were 19.6 percent for calendar year 1965; 16.8 percent for calendar year 1966; and 13.4 percent for the first 4 months of 1967, for an average of 16.8 percent.

The General Accounting Office review of a recent Defense Contract Audit Agency (DCAA) survey indicated that a prior examination of price proposals disclosed a lack of adequate and sufficient support for proposed costs and bases for estimating.

Because of possible deficiencies in Colt's accounting system, the recent profit rates experienced, the amount of questions raised by the Defense Contract Audit Agency in their reviews of Colt's proposals, and in their review of Colt's estimating practices and procedures, the possibility exists that Public Law 87-653 may have been circumvented in the M-16 rifle procurements. (Public Law 87-653 requires reporting by the contractor of the most recent and accurate cost and pricing data on negotiated contracts with the Defense Department.)

It is recommended that the General Accounting Office conduct a complete audit of Colt's military contracts to determine the profit rates experienced, the adequacy of their accounting system and whether the provisions of Public Law 87-653 were circumvented on their military contracts.

ESTABLISHMENT OF A SECOND SOURCE

Subsequent to the Army's negotiating for the production rights and technical data package, a bidder's conference was scheduled by the Army Weapons Command to solicit interest from potential producers of the rifle. Some 25 firms were invited to attend the conference at Rock Island Arsenal, Ill., in mid-September. Before the scheduled date arrived, the conference was postponed to October 3, 1967. On that date, some 21 industrial firms sent representatives to the conference. A solicitation for proposal was issued to each interested firm. The solicitation calls for a two-step multiyear procurement of 167,000 M-16 rifles. However, the Army indicated a possible desire for a Government option to increase this quantity by as much as 150 percent.

The subcommittee is advised that the technical data package, necessary for proposals to establish a second source, will not be available

until January 1968. Direct proposals are to be submitted on or before February 5, 1968, with firm fixed-price proposals to be submitted by May 10, 1968. Under the schedule outlined, first deliveries of rifles from a second source are not anticipated before August 1969.

MOBILIZATION BASE FOR M-14 RIFLES

During the procurement of the M-14 rifle, the Army established three industrial producers and furnished Government production equipment valued at almost \$19 million. Since the last procurement of M-14's 4 years ago, more than \$2 million has been expended to maintain the production equipment at all three facilities in a standby condition.

In view of the reported Defense decision in December of last year to replace all .30 caliber rifles with the M-16 and the subsequent adoption in February of this year of the M-16 as a "standard" weapon, the subcommittee finds it hard to understand why it is necessary to continue to maintain such a broad mobilization base for a weapon that hasn't been procured since 1963. According to information furnished the subcommittee between 75 and 95 percent of the M-14 production machinery could be used to produce M-16 rifles.

In view of these facts, the subcommittee recommends that serious consideration be given to utilizing the equipment and facilities of at least one of these rifle mobilization designees for the production of M-16 rifles.

VIETNAM INVESTIGATION

Shortly after beginning its review of the M-16 rifle program, the subcommittee witnessed two malfunctions during firing demonstrations on the range at Fort Benning, Ga., and Camp Pendleton, Calif. Many reports of similar or worse malfunctions being experienced in Vietnam continued to come to our attention. In view of these reports and the malfunctions personally witnessed by members of the subcommittee, the chairman of the House Armed Services Committee, the Honorable L. Mendel Rivers, directed the subcommittee to visit Vietnam and attempt to determine the extent of the problem and the possibility of immediate corrective action, if such were necessary.

The subcommittee departed for Vietnam on June 1 and returned on June 11, 1967. While there we visited units representing all infantry divisions of both the Army and the Marine Corps in Vietnam. In addition, meetings were held with logistics support and maintenance personnel at various levels.

Army problems with the M-16

At Headquarters, U.S. Army Vietnam, the subcommittee was briefed on problems experienced by several Army units last fall and first reported in October. At the request of this Army headquarters, a technical assistance team consisting of representatives of the Army Weapons Command and Colt Firearms was sent to Vietnam on October 19, 1966, to determine the cause and solution for excessive malfunctions being experienced with the M-16 rifle. The technical assistance team, organized into four units of two men each, visited units throughout Vietnam during the period October 21 through December 7. Classes were held for the purpose of providing maintenance instruc-

tion to the military personnel. The following was contained in their report dated December 15, 1966, which was addressed to the Commanding General, U.S. Army Materiel Command:

In all classes the students brought their own weapons, magazines, ammunition, cleaning material, and accessories. A detailed inspection of each weapon, as well as the ammunition and magazines, revealed that with the exception of the 1st Brigade of the 101st Abn Division, the 173d Abn Brigade, and the 5th Special Forces Group, the weapons were in an unbelievable condition of rust, filth, and lack of repair. The filthy condition ranged from actual dirt, grit, and mud on various components of the weapon and ammunition to a heavy carbon deposit on various components. The most significant trouble spots were the chamber, the outside of the gas tube extension in the upper receiver, and the inside of the carrier key. Questions asked of the students in the 1st and 2d echelon classes revealed (with the exception of the three units mentioned) that the weapons had been issued to the units just before they came to Vietnam or after they were in Vietnam, CONUS replacements had had training in marksmanship only, there was a shortage of technical manuals, and there was a shortage of cleaning equipment, there was a shortage of repair parts, and there was a shortage of officers and NCO's who knew anything about maintenance of the rifle.

The report by the technical assistance team further states:

In all units there was a lack of attention to the magazines and ammunition. Both were inspected during the 1st and 2d echelon classes. Approximately 5% of the ammunition was unserviceable due to corrosion and an additional 10% would have given trouble due to being dirty. From 30 to 50% of the magazines appeared to be unserviceable due to bent or spread lips.

The technical assistance team also reported that:

The instruction given by the team, if properly disseminated and followed up, will alleviate most of the difficulties and the rifles will perform well. The shortages of repair parts, cleaning materials, and technical manuals are basically an internal problem within Vietnam which can be corrected only by command emphasis by USARV and the commanders of the units concerned.

It is concluded that the malfunction problem with the XM16E1 rifle did exist and was the result of insufficient training of the personnel prior to using the weapon; a shortage of technical manuals, repair parts, and cleaning equipment; a lack of knowledgeable officers and NCO's and an apparent lack of CONUS emphasis on maintenance training.

The subcommittee was advised that the technical assistance teams achieved outstanding results as units implemented maintenance procedures they prescribed. We were further advised that:

To spread the gospel, command directives and messages from the Military Assistance Command and this headquarters have stressed the need for adequate command supervision of maintenance programs. Command emphasis also has been placed on the importance of maintenance through the use of "advertisement" type publications such as the USARV *Combat Lessons Bulletin* and a special USARV Pamphlet 750-5 on preventive maintenance of the M16A1. The aforementioned publications have received wide dissemination to company level in USARV. *The pamphlet is distributed to every soldier.*

The subcommittee later discovered that the referenced pamphlet on preventive maintenance had not been distributed to individual Marines at the time of our visit. However, 5,000 to 10,000 copies had been requested by the Marines.

A serious malfunction of the M-16 was reported to be the failure to extract the spent cartridge. The Army Weapons Command contends that the major cause of this type failure is not the design of the weapon, but rather inadequate cleaning and a failure to replace worn components. To emphasize proper operator maintenance, the Weapons Command, on October 25, 1966, made wide distribution of a list of instructions that were considered essential to overcome or substantially





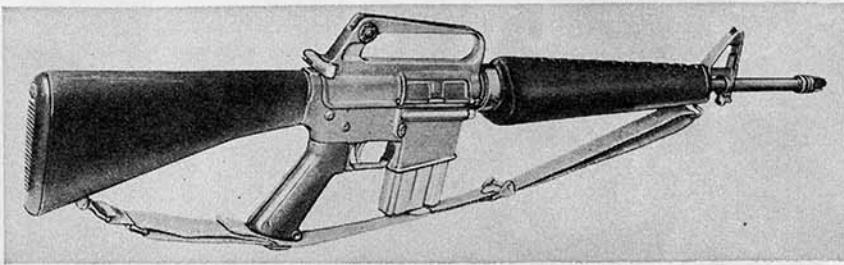

U.S. Rifle M16, Caliber 5.56mm



U.S. Rifle M16A1, Caliber 5.56mm

U.S. Rifle M16A1,
Caliber 5.56mm
(note bolt closure push rod)

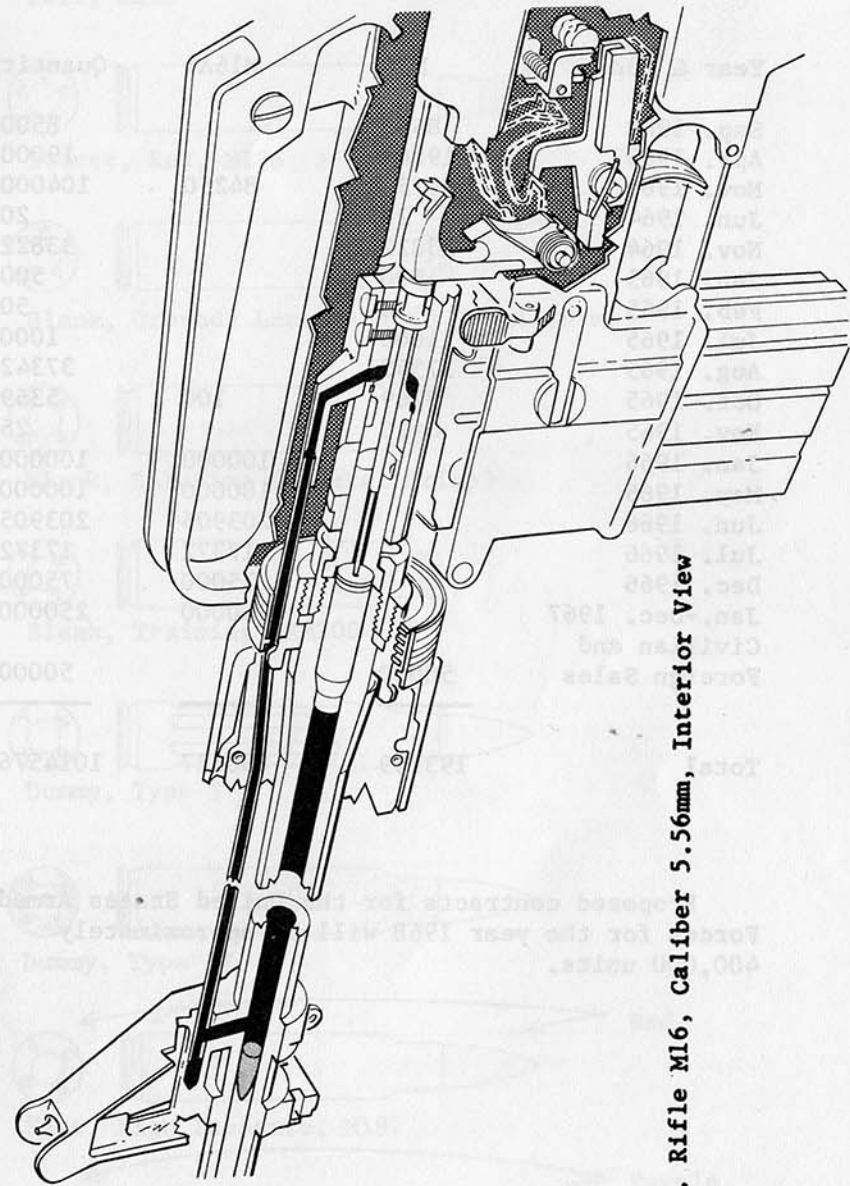

U.S. Rifle M16, Caliber 5.56mm, Interior View

PRODUCTION QUANTITIES OF RIFLE M16 AND M16A1

Year & Month	M16	M16A1	Quantity
Sep. 1962	8500		8500
Apr. 1963	19000		19000
Nov. 1963	19750	84250	104000
Jun. 1964	20		20
Nov. 1964	33822		33822
Jan. 1965	500		500
Feb. 1965	50		50
Jul. 1965	1000		1000
Aug. 1965	37342		37342
Oct. 1965	5269	100	5369
Nov. 1965	25		25
Jan. 1966		100000	100000
May. 1966		100000	100000
Jun. 1966		203905	203905
Jul. 1966		17372	17372
Dec. 1966		75000	75000
Jan.-Dec. 1967		250000	250000
Civilian and Foreign Sales	50000		50000
Total	193949	830627	1014576

Proposed contracts for the United States Armed Forces for the year 1968 will be approximately 400,000 units.

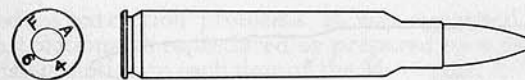

Ball, M193

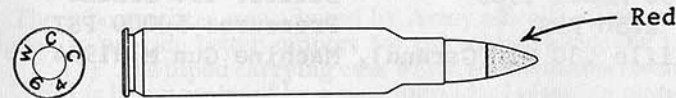

Tracer, Red, M196

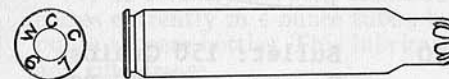

Blank, Grenade Launching (8 Petal Crimp)

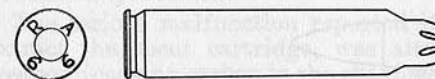

Blank, Saluting (5 Petal Crimp)

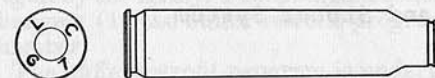

Blank, Training, XM200

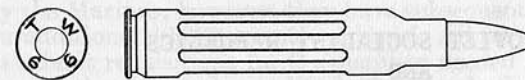

Dummy, Type I



Dummy, Type II

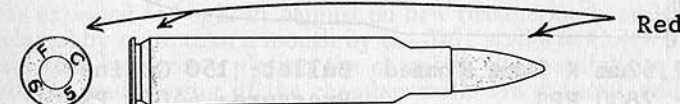

Test, High Pressure, M197

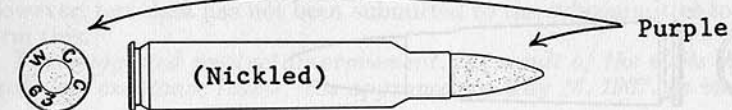

Test, High Pressure, M197 (Alternate Marking)

UNITED STATES



Caliber .30 Model 1906 Bullet: 150 Grains
 Velocity: 2750 FPS Pressure: 50000 PSI
 Weapon: Rifle .30 M1 (Garand), Machine Gun M1919A4



Caliber 7.62mm X 51mm NATO Bullet: 150 Grains
 Velocity: 2750 FPS Pressure: 50000 PSI
 Weapon: Rifle M16, Machine Guns M60 and M73

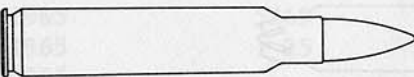

Caliber 5.56mm X 44.5mm Bullet: 55 Grains
 Velocity: 3250 FPS Pressure: 52000 PSI
 Weapon: Rifles AR15, M16 and Stoner System

UNION OF SOVIET SOCIALIST REPUBLICS
 AND
 COMMUNIST CHINA

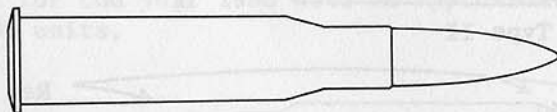
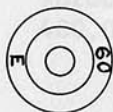

Caliber 7.62mm X 54mm Rimmed Bullet: 150 Grains
 Velocity: 2800 FPS Pressure: 44000 PSI
 Weapons: Rifle M91 Moisin/Nagant, Maxim Machine Gun



Caliber 7.62mm X 39mm M43 Bullet: 122 Grains
 Velocity: 2400 FPS Pressure: 42000 PSI
 Weapons: Rifles SKS46, AK47, Machine Gun RPD

reduce extraction problems. It was suggested that this short list of instructions be reproduced or prepared on a local basis for immediate dissemination to each user of the M-16 rifle. *At the time of the subcommittee's visit there was no evidence that this had been done.*

Changes in support of M-16 rifles

The subcommittee was advised by Army officials of two changes designed to provide better support for the soldier using the M-16 rifle:

(1) The bipod carrying case which also contains cleaning material is being replaced by a new individual cleaning materials case. The new case is much smaller and will contain a newly designed four-piece cleaning rod.

(2) A recently adopted standard lubricant (MIL-L-46000A) comes currently in 4-ounce tubes, but will be available soon in 2-ounce squeeze bottles. This lubricant replaces the preservative oil and rifle grease.

These items were not in the hands of the troops at the time of the subcommittee's visit.

Product improvement

The serious malfunction reported in October 1966, the failure to extract the spent cartridge, was attributed to overlubricating the weapon (causing carbon in the chamber according to the Army), dirty ammunition, and failure to replace worn parts. Reportedly, in recognition of potential problems, a product improvement program was begun by the Army. This program consists primarily of two important changes: (1) the buffer retrofit program, and (2) chrome plating the chamber.

The buffer retrofit program is underway now, and instructions have been given to the field for its implementation. However, at the time of the subcommittee's visit, only 12,500 of the 50,000 modified buffers received in Vietnam had been distributed; none had been received by the Marines; however, they have subsequently received 10,000 with an additional 12,292 recently shipped. All units have been instructed to submit requisitions for the quantity needed along with serial numbers of the rifles to be modified. The new buffer is designed to reduce slightly the cyclic rate of fire. *If this was intended to improve the weapon and reduce certain malfunctions, it is difficult for the subcommittee to understand the lackadaisical manner in which it was implemented. Administrative issue of the new buffers should have been made as soon as possible after arriving in Vietnam with reporting from the units after the fact. Distribution could have been made on a pro rata basis while accounting procedures were being established.*

The second product improvement, chrome plating of the chamber, was expected to begin in August on new production barrels. This was delayed by more than a month by the July strike at Colt's plant. It is said that by chrome plating the chamber, the possibilities of carbon buildup and scoring of the chamber walls are reduced, and cleaning of the weapon is facilitated. A test of a few weapons in Vietnam with chrome chambers reportedly confirmed the value of this improvement; however, test data has not been submitted to the subcommittee to confirm this.

This suggested product improvement, the result of the visits by the technical assistance teams, was approved on May 26, 1967. In view of

its importance, the subcommittee is greatly disturbed by the timelag of over 4 months before the improvement is reflected in the production line. The subcommittee observes that if this product improvement that allegedly will eliminate or drastically reduce the extraction problem, it should have been accelerated and incorporated into production rifles as soon as possible.

During 1967 two additional Army Weapons Command teams have visited Vietnam as followup on the recommendations made by the first team and to provide additional training and technical assistance to the soldier. The latest team was in Vietnam during the first 2 weeks of May. Their report dated May 25, 1967, stated that the team "examined large numbers of M-16A1 rifles in the hands of troops with primary emphasis on determining the status of maintenance, availability of cleaning materials, and the condition of rifle barrels and chambers."

The report contained the following:

The Army units contacted report little or no problems with the M-16A1 rifle. The extraction problem still exists to some degree, but the frequency with which this malfunction occurs has been reduced and minimized due to the increased emphasis on care and cleaning at the unit level, increased logistical and command emphasis on making cleaning materials available and the continuing education program in effect to teach the soldiers how to avoid the problem. The personnel of all ranks with whom I spoke expressed satisfaction with the weapon and agree that it is superior to the M-14 rifle in this tactical environment.

The Weapons Command team reported that a condition frequently observed was the accumulation of thick deposits of copper fouling in the rifle bores. "This condition appeared worse in those units which habitually fire a large volume of tracer ammunition. In one brigade it was reported that 800 barrels had been replaced in recent months due to this condition alone."

The May 25 report indicated that all Army units except one had an ample quantity of cleaning material on hand. The one unit had recently arrived in Vietnam and had not had as high usage of cleaning items as the other more well-established units; therefore, its requisitioning objectives had not been as high. It was stated that this one unit did have some quantity of all items on hand.

The Army Weapons Command team concluded in its May 25 report:

The M-16A1 rifles in the Army units visited were in good condition. Logistical and Command emphasis on making cleaning materials available and the continued education and emphasis on care and cleaning have contributed significantly to the reduction of weapon malfunctions. Amazingly few weapons were found in the shops awaiting repairs and no weapons were found to be unrepairable due to a lack of parts.

The major problem found was the deterioration of rifle barrels due to chamber pitting and accumulation of copper fouling. The chamber pitting may be due to the previous short supply of cleaning materials and previous lack of emphasis on the need for frequent and thorough cleaning. The copper fouling may be attributed to the use of a large volume of tracer ammunition.

The team recommended:

(1) That both tactical and logistical units continue to stress the importance of frequent and thorough cleaning of the M-16A1 rifle, with particular emphasis on the chamber and bore.

(2) That continued emphasis be placed on making cleaning materials available to the troops. This emphasis must continue throughout the pipeline—from manufacturer to ultimate user. The selective management techniques presently being employed to insure an adequate supply of these items must continue until

such time as all needs have been met and the pipeline is sufficiently filled to permit return to normal supply procedures to satisfy requirements.

(3) That Division and Separate Brigade T/O & E's be reviewed by appropriate agencies to determine if the number of Small Arms Repairmen MOS 42110 (45B20) authorized in organic Direct Support Maintenance units is adequate to support the assigned weapon densities. In those units where the repair requirements exceed the capability of organic personnel, assistance should be sought from back-up support DS and GS units assigned to the 1st Log Command.

(4) Field Commanders should be advised of the potential problems associated with the use of tracer ammunition. Tracer ammunition characteristically leaves more fouling in rifle bores, causes more rapid deterioration, and necessitates more frequent and thorough cleaning. It is recommended, therefore, that the use of tracer be limited to the least proportion which provides the necessary visual display for any particular tactical situation. The use of tracer for general purpose ammunition should be discouraged.

(5) That a supply control study be conducted by the Supply and Maintenance Directorate, U.S. Army Weapons Command, to determine if present rifle barrel production is adequate to support the anticipated usage of barrels (estimated 10% per quarter). If the study indicates a requirement above present production capacity, additional production capability should be added as soon as possible.

(6) That U.S. Army agencies charged with the responsibility for small arms product improvement continue to seek methods of reducing rifle malfunctions. Of primary importance is the extraction problem which is aggravated by pitted chambers. Pitting and deterioration of rifle chambers is caused by improper or insufficient cleaning. Suggested as a possible product improvement is chromium plating of rifle chambers. Another product improvement presently being incorporated in new rifle production and as a part of an existing retrofit program is the replacement of the present buffers (Guide Assembly, Action Spring (62219)) with a buffer of improved design. This program must be closely monitored by all responsible agencies to insure that it is completed without delay.

(7) That the improved lubricant (MIL-L-46000A) recently adopted as the preferred lubricant/preservative for M-16A1 rifles be procured and distributed to the field as soon as possible. Once made available, every practical means should be used to disseminate the proper lubrication/preservation procedures to the using units. In addition to timely changes to appropriate technical manuals, such media as PS Magazine and AFRS Radio and TV should be considered as a means of disseminating this information.

(8) That a borescope, similar to the AMCI Borescope manufactured by the American Cystoscope Makers, Inc., be procured and issued to all Direct and General Support units with an M-16A1 rifle support mission to permit closer inspection of rifle chambers and bores. No visual aids are presently available to the maintenance personnel to perform this inspection.

Interviews with Army combat personnel

During our visit to Vietnam the subcommittee interviewed combat personnel from the delta area of the south to the demilitarized zone (DMZ) in the north. Hundreds of GI's were questioned on their experiences with the M-16. Among the Army units visited in the II Field Force area, only two soldiers stated a preference for the M-14 over the M-16. Many had experienced malfunctions in the past but few were now having any problem. Most Army units were required to clean their weapons prior to going out on patrol and upon return. One unit of the 1st Infantry Division had just returned from patrol before our visit. They reported that in testing their weapons upon return, 20 rounds were fired in each weapon with only two weapons out of 154 failing to fire. The two malfunctions were readily cleared by hand and were not considered serious.

The men of the 173d Airborne Brigade stated that they had no problems with the M-16 rifle as long as it was properly assembled and adequately cleaned. They stated that under extreme conditions, the unit commander issued orders during halts and rest periods for half

of the men to disassemble and clean their weapons while the other half remained ready for action. This practice was repeated whenever possible. The men stated a preference for the M-16 but indicated that it required more detailed and frequent cleaning than does the M-14. An armorer of this unit was of the opinion that chrome-plating of the chamber would make the weapon much easier to clean. A company commander of this unit stated that he had instructed his men to use tracer ammunition only when necessary because of his belief that it was harmful to the weapon. The unit commander stated that he was completely satisfied with the M-16 rifle and wanted no other weapon under this type combat condition. The unit had no trouble getting adequate cleaning equipment. The officers and NCO's of the unit supervised the cleaning and care of the rifle.

A unit of the 4th Infantry Division that had just completed a severe firefight stated that they had very few malfunctions during the fight. It was their experience that some magazines would hold 20 rounds while others would take only 19. Because of this inconsistency, the members of the fire teams loaded only 17 to 18 rounds to insure that the weapon would fire the first time. The platoon leaders supervised the daily cleaning of the rifles and the loading of the magazines. This unit believed that the magazine and ammunition played a great role in the malfunctions experienced.

The information obtained from members of the other Army divisions visited was very similar with the exception of the 1st Cavalry Division and the units participating in Task Force Oregon. Of approximately 75 members of the 1st Infantry Division units in Task Force Oregon, almost 40 percent stated a preference for the M-14 rifle over the M-16. Malfunctions experienced were: selector switch sticking, stoppage due to dirty ammunition, failures to extract, and failures to extract rounds left in chamber overnight. There was evidence of some shortages of cleaning materials. Some men were having to share cleaning rods.

Of the 30 members of the 1st Cavalry Division interviewed, 21 had experienced failures to extract at one time or another. Some of these men lubricated the ammunition in the magazine, which is not in accordance with instruction. At least four of the men interviewed did not have cleaning rods and a similar number were without brushes.

The information received from the 1st Cavalry Division was most disturbing in view of the December report of the Army Weapons Command technical assistance team, which stated:

1st, 2d, and 3rd echelon instruction was not given to the combat brigade of the 1st Cavalry Division. This Division stated that they were not having any trouble with the rifle and requested that the instruction be given only to the small arms shop of their maintenance battalion.

The instructions for preventive maintenance, mentioned earlier in the report, which reportedly was to have been distributed to every user of the M-16 rifle, had not been received by the men of the 1st Cavalry Division at the time of our visit. The units of the 1st Infantry Division participating in Task Force Oregon were also without the preventive maintenance pamphlets and the cleaning instructions to prevent extraction problems.

Interviews with Marine Corps combat personnel

Interviews were conducted with units from all Marine regiments presently in Vietnam. Of the Marines interviewed, approximately 50

percent had experienced some type of malfunction such as: failure to fire, failure of the bolt to close, failure to feed, failure to eject, failure of the selector lever, and failure to extract. Of these malfunctions, the most prevalent and most serious is the failure to extract, which comprised about 80 percent of the total malfunctions. Most, if not all, of the others can be corrected with the individual's bare hands or by using a knife or bayonet. In the case of a failure to extract, it usually requires a forceful push of the cleaning rod from the muzzle of the rifle barrel. Since the cleaning rods are to be carried disassembled in the carrying case, it takes time to locate and assemble the rod before one can remove the stuck cartridge. If a soldier fails to carry a cleaning rod, this necessitates borrowing a rod from another soldier, hopefully nearby.

The reported death of one corporal, killed while running up and down the line of his squad pushing out cartridges which failed to extract with the only cleaning rod in the squad, was confirmed by our investigation.

One battalion commander, who was no longer with the unit, gave instructions to the battalion armorer to issue only one cleaning kit for every four men. In case a cleaning rod was lost or broken this meant further doubling up in the use of this vital equipment. At the time of the subcommittee's visit this situation still prevailed in at least one company. Prior to our departure from Vietnam, cleaning kits had been issued to each man in that company. However, the cleaning kits did not include the new lubricant which was reported to be in Vietnam at the time.

Because of the malfunctions personally experienced or reported by others, many of the Marines lacked confidence in the M-16 rifle. In addition to the malfunctions experienced, much of the dissatisfaction with the M-16 might be attributed to a lack of proper training and familiarity with the rifle. None of the enlisted Marines had possession of preventive maintenance pamphlets, manuals, or other written instructions. Many had received very little oral instruction in the care and cleaning of the weapon. While it was reported that sufficient cleaning materials were on hand at the battalion levels, numerous shortages were noted at the company and squad levels.

Several of the Marine units visited had no organized supervision in the care and cleaning of the rifle. In checking the rifle of one Marine who had returned from a patrol some 14 hours earlier, it was found to be clogged with wet sand. Daylight was not visible through the barrel. It is suspected that the rifle would have exploded had it been fired in that condition. However, that same Marine had fired over 500 rounds with the M-16 rifle in combat and had experienced only two failures to extract.

Many of the M-16 rifles issued to the Marines contain the new buffer, designed to slow down the cyclic rate of fire; however, these new weapons are still experiencing failures to extract. The subcommittee was advised prior to going to Vietnam that the rifles produced after December 1966 have the improved buffer (action spring guide assembly). It is noted that the reason given by the Army for this product improvement was "to improve reliability by reducing cyclic rate and eliminating possible bolt carrier bounce and increase parts life." Therefore, the subcommittee questions the effect this "product improvement" will have on the problem of failing to extract.

One possible cause of malfunctions of Marine rifles is the use of an improper cleaning solvent. The accepted cleaning solvent for the chamber and bore of any weapon is a commercial cleaning solvent. Many of the marines questioned were using diesel oil to clean the chamber and bore of the M-16. According to technical publications, this is not the proper cleaning material to clean the weapon of corrosion, carbon, and other chemicals resulting from firing the weapon.

While in Vietnam, the subcommittee received suggestions from several of those interviewed that the ammunition should be checked as a possible cause of malfunctions. This was done upon our return and is covered in the next section of the report.

AMMUNITION

According to Dr. Wilbur B. Payne, Chief, Office of Operations Research, Army, for 26 years the military has been locked into a sole-source procurement of a propellant for which the design objective was to permit reuse of scrap and surplus cannon powder.

Dr. Payne stated in a memorandum of February 10, 1967, to the Under Secretary of the Army that ball propellant was adopted with a total absence of comparative tests from the time of its adoption to the M-16 rifle experience.

Ball propellant was adopted by the U.S. military for .30 caliber carbine ammunition in 1942. The Army adopted ball propellant in 1951 as the "preferred" propellant for caliber .30 and caliber .50 ammunition. Ball propellant was adopted in 1953 as the "standard" for .20 mm., M-50 series ammunition, and also as the "standard" for 7.62-mm. ammunition.

In April 1954, the Chief of Ordnance directed that all military small arms ammunition should eventually be loaded with ball type propellant powder which was (and is) produced only by Olin Mathieson.¹⁵ This is a double-base (nitrocellulose-nitroglycerine) propellant commonly called ball powder and is a spherical grain coated with dibutylphthalate.

The M-16 (AR-15) rifle was initially developed, tested, and evaluated using commercial ammunition loaded with IMR 4475 propellant. The initials IMR stand for improved military rifle. IMR 4475 is a grade of rifle powder first introduced by the Du Pont Co. in 1936 for use in both military and commercial cartridges.

Propellants of this type are single-base (nitrocellulose) tubular-grain and employ dinitrotoluene (DNT) as a deterrent coating to control the rate of burning. Of this type ammunition it is said that the ballistic and chemical stability has been found generally excellent both in accelerated aging tests and in long-term service use. The IMR powder supplied for the 5.56-mm. cartridge is the same, except for minor modifications, as the propellants supplied by Du Pont for military small arms loading since the early 1920's, and was the type used in practically all of the U.S. and most of the British rifle and machine-gun ammunition from caliber .30 through .20 mm. in World War II. IMR 4475 has also been used in loading 7.62-mm. ammunition for the M-14 rifle. Propellants of the IMR type are commercial products exclusively of the Du Pont Co. in the United States.

Between the time the M-16 program was authorized and the placement of the initial contract, there was much discussion before the Technical Coordinating Committee on the problem of establishing an ammunition specification acceptable to all services. The first Air Force procurement of the rifle was accompanied by a procurement of 8½ million rounds of ammunition loaded with a single base extruded propellant (IMR 4475). This ammunition was procured as an off-the-shelf commercial item and was produced under Remington's commercial specification.

It was testified that this Remington ammunition was the same as that used in the rifle during earlier tests by the Air Force, the Army, and the Advanced Research Projects Agency (ARPA). However, during the life of this first ammunition contract, the Air Force received adverse reports from various users. Because of these adverse reports, the Air Force conducted a test at Hill Air Force Base to determine the status of the .223 ammunition then in Air Force inventory. Approximately 1,000 rounds from each of eight lots were tested. These rounds were observed for penetrating ability, function and casualty pressures, velocity, waterproof, accuracy, bullet extraction, and a mercurous nitrate test. The test report dated July 1963 concluded "That the Air Force inventory of caliber .223 cartridges met the requirement of MIL-C-9963A and performance characteristics for the new USAF specification weapon." It was recommended that this ammunition be released for unrestricted field use.

The ballistic specification of the commercial cartridge used in the development and testing of the M-16 included a normal mean velocity of $3,250 \pm 30$ feet per second (f.p.s.) and a mean chamber pressure not to exceed 52,000 pounds per square inch (p.s.i.). In June 1963, Frankford Arsenal issued a report based on examination of the manufacturer's test reports as well as the ballistic testing of chambers at the arsenal which contained the following observation regarding the attainment of the stated commercial ballistics.

While these ballistics are attainable, the achievement of the required velocity has in experience allowed a very small margin below the maximum permissible chamber pressure for most lots of ammunition. For large-scale production of military ammunition (should that hypothetically be contemplated) experience has shown that a somewhat more conservative margin should be maintained between the typical chamber pressure of production lots and the maximum level permitted.

It was recommended at that time by Frankford Arsenal that consideration be given to a reduction in muzzle velocity which would permit lower chamber pressure and a concomitant adoption of an alternate bullet having improved aerodynamic design which would at the same time improve impact energies at all ranges beyond 100 yards. This recommendation was not approved.

The initial Army technical data package for 5.56-mm. ammunition (MIL-C-46381(MU) dated June 26, 1963) was based on the commercial ballistics requirements with only a slight amendment based on further review of commercial manufacturing experience. The mean velocity was specified as 3250 ± 40 f.p.s., while the mean chamber pressure specification remained the same, that is, not to exceed 52,000 p.s.i. The same requirements appeared in three successive revisions of the technical data package. However, an attempt to utilize this specification for military procurement in January 1964 elicited statements

¹⁵ General Accounting Office Report No. B-146977 dated March 31, 1965.

from commercial producers that a relaxation of these requirements was required to enable procurement from them.

On October 8, 1963, the Air Force awarded a contract to Remington Arms Co. for 19 million rounds of ammunition under the USAF specification, MIL-C-9963A, which was coordinated with the Army. The specification called for IMR-4198 propellant and stated that IMR 4475 was considered an equal and interchangeable type propellant. According to the Air Force, the specification further stated that any propellant meeting the pressure, velocity, and environmental requirements of the specification would be considered equal to the propellant specified.

Remington chose to load the ammunition with WCC-846 propellant, a doublebase ball propellant which uses both nitrocellulose and nitroglycerine. The preproduction lot test reports met the requirements of the military specification and all production lots were loaded with the ball propellant.

After a conference of January 17, 1964, between Government and contractor personnel, the maximum acceptable mean chamber pressure was increased to 53,000 p.s.i. It is said that this change enabled the procurement of 1 million rounds required but illustrated the likelihood that some change in design of the commercial .223 cartridge might be required if the stated ballistics requirements were to be met consistently in large-scale production. The 1 million cartridges were loaded with IMR 4475 propellant and were the last ball ammunition to be loaded with IMR 4475.

In February 1964, the Army requested the three U.S. propellant manufacturers to submit candidate propellants for testing as replacements to the IMR 4475. The desired propellant was to allow achievement of the required velocity of 3,250 f.p.s. and a chamber pressure substantially less than that produced with IMR 4475. Further it was required that any propellants to be recommended should not be significantly inferior to IMR 4475 in other characteristics such as smoke, flash, fouling, barrel erosion, storage stability, or performance at environmental extremes and were to be producible in large quantities from available materials in the event of their successful performance and adoption for use.

Based on the tests conducted, the candidate propellant submitted by Du Pont (CR 8136) and the propellant submitted by Olin Mathieson (WC 846) were recommended to be approved for use as permissible alternates to IMR 4475 in the loading of 5.56-mm. ball ammunition. It was concluded that "cartridges loaded with these two propellants afford substantial advantage over IMR 4475 as regards velocity/pressure relationship."

On the fiscal year 1964 ammunition procurements, Olin Mathieson chose to load with WC 846 ball propellant and Remington elected to use IMR (CR) 8136. After production of approximately 50 million rounds loaded with this IMR propellant, Remington again indicated difficulties in meeting the velocity/pressure requirements and began loading with WC 846 ball propellant in December 1964. Of the 132 million rounds of 5.56-mm. ammunition procured during fiscal year 1964, 1 million rounds were loaded with IMR 4475, 50 million with IMR (CR) 8136, and 81 million rounds were loaded with WC 846 ball propellant.

In February 1965 the Army again requested the propellant manufacturers to submit new candidates for the 5.56-mm. cartridge. Du Pont submitted IMR 8208M and Hercules Powder submitted its HC-11. Olin Mathieson reported that they were unable to offer a candidate better than WC 846. Of the two submitted, the one loaded with IMR 8208M reportedly met all requirements and was approved. The Hercules powder failed the fouling test requirement and was disqualified, according to the Army.

The subcommittee notes that samples of ammunition containing propellant candidates were received by Frankford Arsenal in September 1965 for testing; however, it was not until April 1966 that the test reports were approved by the Technical Coordinating Committee and IMR 8208M submitted by Du Pont was qualified and the Hercules submission disqualified. This delayed action indicates to the subcommittee a lack of any sense of urgency on the part of the Army.

Initial production of 5.56-mm. ammunition loaded with IMR 8208M began in May 1966. Deliveries of ammunition loaded with this propellant were not scheduled to arrive in South Vietnam before June or July of 1967. However, the Marine Corps reported that as of August 10, 1967, the Marine units in Vietnam have not received any 5.56-mm. ammunition using IMR propellant.

Fouling test specification

The initial ammunition specification of the Air Force and that adopted for the initial Army procurement failed to include a fouling requirement for acceptance testing. A subcommittee was appointed in March 1964 by the Chairman of the Technical Coordinating Committee to study various proposals for a technical data package for ammunition. At a meeting of the Technical Coordinating Committee on March 24, 1964, the subcommittee recommended an engineering change to the proposed technical data package to include a fouling requirement in the ammunition test procedure. The reason for the change was stated "To prevent the acceptance of ammunition which may cause weapon stoppages due to excessive deposition of residue on firing." As further justification for this change, it was stated that "Ammunition utilized in acceptance testing for Colt has exhibited various degrees of fouling characteristics. In certain lots several thousand rounds may be fired from the weapon (without clearing) without any evidence of malfunction due to fouling. In other lots stoppages have occurred due to fouling in as little as 500 to 600 rounds."

The contractor (Colt's) and the four services agreed that this engineering change should be incorporated into the technical data package with application to fiscal year 1965 procurement. The engineering change required a 1,000-round fouling test to be successfully conducted on each preproduction lot as a condition of acceptance.

The subcommittee notes that this specification calls for testing of fouling characteristics of preproduction lots only and does not apply to normal production lots. Therefore, it is possible for an ammunition contractor to continue to produce ammunition indefinitely without production lots being subjected to this test once the initial preproduction sample has been approved. Under this specification, an ammunition contractor could produce millions of cartridges over an indefinite time period after the first 1,000 rounds passed the fouling test so long

as there was no change in the ammunition specification. (The subcommittee notes one contract with Olin-Mathieson was for 59 million cartridges.)

It is the subcommittee's view that the fouling test should be applied to all production lots of ammunition and not just to the initial preproduction lot in view of the possible malfunctions related to excessive fouling within the weapon.

Increased cyclic rate caused by ball propellant

At this same meeting of the Technical Coordinating Committee, March 24, 1964, a Colt representative remarked that the current Army contract "imposes a cyclic rate restriction of 650 to 850 rounds per minute as a condition of acceptance. The current USAF contract (fiscal year 1963) permits 900 as the upper limit on cyclic rate." He further stated that a recent test conducted at Colt's using 10 weapons and two lots of ammunition resulted in six of the 10 weapons exceeding the cyclic rate test when firing ammunition loaded with WCC-846 ball propellant. Of the 10 tested firing IMR-4475 propellant, one weapon exceeded the upper limit of the cyclic rate by five rounds per minute. Colt's requested that the upper limit of the cyclic rate acceptance requirement be increased to 900 rounds per minute for those weapons delivered during April 1964 on the fiscal year 1964 contract.

Waiver of cyclic rate acceptance test

With reference to the shipment of the first 300 guns scheduled for delivery in March under the Army contract, it was stated that Colt's had been able to meet the cyclic rate problem through selection of weapons meeting the established criteria. The service representatives attending the Technical Coordinating Committee meeting concurred in the request by Colt. However, "it was emphasized that this change would apply only to the weapons delivered in April." This waiver was subsequently extended to production in the months of May, June, and July of 1964. The subcommittee observes from the delivery schedule that under this waiver some 12,400 rifles were delivered and accepted by the Army that failed to meet the intended operational specification. There is no evidence that the Army made any attempt to recall these weapons or determine their operational suitability after it was determined that the high cyclic rate was related to certain malfunctions of the rifle. It is conceivable that a substantial quantity of these rifles was issued to the troops in Vietnam and could be among those exhibiting less than desirable reliability.

(Following the 4-month waiver on the upper limit of the cyclic rate for the acceptance test, Colt's apparently was allowed to select the ammunition used in the rifle acceptance tests. Colt's chose ammunition loaded with IMR extruded powder because of the cyclic rate test and the consistency of favorable test results obtained when firing IMR ammunition. Between the date of incorporating a new buffer in the rifle in production, December 1966, to slow down the cyclic rate, approximately 330,000 rifles were accepted from Colt's by the military. More than 218,000 of these were delivered to the Army. Undoubtedly many thousands of these were shipped or carried to Vietnam, with the Army on notice that the rifles failed to meet design and performance specifications and might experience excessive malfunctions when firing ammunition loaded with ball propellant. It was also known that 90

percent or more of the 5.56 millimeter ammunition delivered to Vietnam was loaded with ball propellant.)

Air Force experience with AR-15

The March 24, 1964, meeting of the Technical Coordinating Committee also included a review by the Air Force representative of the endurance testing data developed at Colt's as a result of the Air Force fiscal year 1963 procurement program. The data presented to the committee indicated that 27 guns had each been fired 6,000 rounds. Malfunctions totaled 55, or one per 3,000 rounds. The parts replacement rate was one per 6,200 rounds.

The Air Force representative, Mr. Aumen, made the following conclusions concerning the weapons being received on the fiscal year 1963 Air Force procurement program:

1. Weapons function well.
2. Require minimum parts replacement,
3. Good velocity life,
4. No apparent decrease in accuracy,
5. Serviceable life beyond 6,000 rounds.

In testimony before the subcommittee, Mr. Aumen indicated that the endurance testing statistics were expanded to include an additional 13 rifles subsequently tested. The last 13 rifles tested gave an average malfunction rate of one stoppage per 6,500 rounds.

The subcommittee notes that the reported reliable performance of the Air Force weapons was obtained with the IMR-4475 propellant even though the velocity obtained was below the specification of $3,245 \pm 40$ feet per second.

The subcommittee was told that IMR-4475 propellant subsequently became unacceptable to the Army and the Air Force because it failed to meet consistently the velocity and pressure specifications of 3,245 feet per second ± 40 feet per second and 52,000 pounds per square inch. However, the rifle didn't seem to realize this and had performed in a reliable manner when firing ammunition loaded with this propellant.

IMR ammunition used for acceptance test

Army witnesses testified that subsequent to the waiver of the cyclic rate for the July 1964 deliveries, Colt's was able to meet the cyclic rate specification by tightening the action spring. The subcommittee observes that the ammunition used for acceptance testing probably was the basis for meeting the acceptance test rather than the reason given by the Army. Colt's chose to use IMR ammunition in their acceptance test rather than ammunition loaded with ball propellant. The Army position on this matter was that there was no indication that malfunctions would be caused by the higher cyclic rate of fire when using ammunition loaded with ball propellant. Therefore, Colt's had the option of using ammunition from the nearest source of supply for their test purposes. The nearest Government producer of 5.56-millimeter ammunition was Remington which at the time was loading ammunition with IMR propellant. However, the subcommittee notes that even after Remington began loading ball propellant in its WCC-846 ammunition, Colt's continued to use IMR ammunition for acceptance tests.

Further evidence of ammunition effect on cyclic rate

The adverse effect on the cyclic rate of fire was further called to the attention of the Army at a June 3, 1965, meeting of the Technical Coordinating Committee and by a report submitted by Colt's dated November 8, 1965, entitled "The Effect of Ammunition Variables on Acceptance Testing of XM-16E1 Rifles." This report was prepared by Mr. W. C. Davis, engineering project manager, Colt's Firearms Division. During the subcommittee's hearing it was brought out that this same Mr. Davis was formerly an employee of Frankford Arsenal, where most of the ammunition testing has been conducted, and he is now a technical assistant to the M-16 rifle project manager, Army Weapons Command, Rock Island, Ill. The report stated that "During testing of production rifles a marked change in the cyclic rate was observed to correspond with a change from ammunition employing tubular-grain propellant to ammunition employing spherical-grain (ball) propellant. Whereas the typical cyclic rate with the former ammunition was quite close to the desired rate of 750 rounds per minute, the typical cyclic rate with the latter ammunition was substantially higher." The test results indicated that the cyclic rate obtained with the rifles firing ammunition loaded with ball propellant exceeded by over 100 rounds per minute that obtained firing ammunition loaded with tubular grain propellant (IMR). The report further stated that aside from the consideration of rejecting rifles presented for inspection on grounds of cyclic rate, there was a probability of more frequent fatigue failures of the bolt when the cyclic rate of fire is significantly increased. It was stated that "there are also certain malfunctions which occur more frequently when the timing of the gun cycle is materially speeded up."

The conclusions contained in the report were as follows:

There is a clearly significant change in typical cyclic-rate performance of XM16E1 rifles, associated with a change in ammunition types, such as those represented by M193 Ball Lots RA5060 and RA5135 respectively. The conspicuous difference between these lots of ammunition is that different types of propellant were employed.

Weapons which readily meet the present cyclic-rate requirement when using ammunition such as Lot RA5060 will frequently fail the present requirement when using ammunition such as Lot RA5135. The increased frequency of failure is ascribable to an increase in both the mean cyclic rate and in the typical standard deviation of cyclic rate. *For weapons such as those used in this experiment, none are likely to fail with ammunition such as Lot RA5060, whereas more than half are likely to fail with ammunition such as RA5135.*¹⁶

The difference in cyclic rate produced by ammunition differences is such that no controls which might be exercised over manufacture of XM16E1 rifles could guarantee compliance with the present limits imposed upon cyclic rate, if both types of ammunition are to be accommodated. It can be estimated, from the foregoing data, that the upper limit must be extended from 850 rds/min to 1000 rds/min to accommodate ammunition of both types.

*The increase in cyclic rate, associated with use of ammunition such as Lot RA5135, can be expected to reduce the endurance of certain parts (notably the bolt), and to increase the frequency of certain malfunctions*¹⁷ (notably the failure of bolt to latch rearward when magazine is empty. The accumulation of data for a quantitative assessment of these effects is not yet available, because many thousands of rounds are necessary for rendering a statistically sound judgment on parts life and malfunction rate. Nevertheless, it is clear that the present allowances for parts replacement, and for certain types of malfunctions, must be increased if ammunition such as Lot RA5135 is to be accommodated in endurance testing of rifles.

¹⁶ Emphasis added.

¹⁷ Emphasis added.

The subcommittee was advised that no further waivers were approved on increased cyclic rates experienced in the acceptance testing. However, Colt's was allowed to use only IMR ammunition for the acceptance tests.

Report of malfunctions related to ammunition deficiencies

At about this same point in time, November 1965, reports were received from the U.S. Army Combat Developments Command Experimentation Command (CDCEC) Fort Ord, Calif., a participant in the SAWS study, that an unusual number of rifle malfunctions were being experienced because of ammunition deficiencies. These reports were later included in the printed report dated May 10, 1966. Included in that report was the following section citing "Major Causes of Malfunctions in 5.56-mm. Weapons."

Major causes of most malfunctions in the 5.56mm weapons are attributed to an interaction of ammunition (and belt link) deficiencies:

1. Weapon fouling, judged to be caused primarily by qualities of the propellant used in standard ball 5.56mm cartridge.
2. Cycling of weapons in excess of design rates, judged to be caused by combinations of:
 - a. Pressure characteristics of the propellant used in the standard ball 5.56mm cartridge
 - b. Factory calibration of M16E1 rifles for a propellant with different pressure characteristics than that in the standard ball 5.56mm cartridge.
 - c. Mismatch in internal ballistic (pressure) characteristics between the standard 5.56mm ball and tracer cartridges.
3. Misfires caused by too low primer sensitivity and possibly (in the case of the Stoner machinegun) an interaction of low primer sensitivity with effects of too rapid weapon cycling caused by the pressure characteristics of the propellant.
4. Incorrectly manufactured machinegun belt links.

a. Fouling.

Fouling in the 5.56 weapons occurred throughout the experiment. Dirty chambers resulting from rapid carbon buildup caused most of the failure to extract. Fouling remained a problem throughout the experiment, although cleaning and inspection of weapons were considered more stringent than would be possible during combat.

*Inquiry to AMC determined that the propellant adopted for the standard 5.56mm ball cartridge is different from the original propellant used during the development and service testing of the M16E1 rifle*¹⁸ and during the development of the Stoner weapons. A USACDCEC test of samples from the lot of standard ammunition used in the experiment showed more fouling than an AMC provided sample containing the original propellant. This supplemental fouling test was conducted using ammunition lots WCC 6008 and RA 5074. This limited test firing of 12,620 rounds indicated a malfunctions rate of 5.6 per 1000 rounds for the cartridge loaded with ball propellant as opposed to 0.91 for IMR propellant loaded cartridges.

b. Excessive cyclic rate.

Excessive cyclic rates were noted early in the experiment. In addition, surging (uneven firing) was noted when ball and tracer were fired together. There was also an increasing incidence of malfunctions attributed to ammunition cycling the weapons beyond their design rates. The cyclic rates were higher than the design cyclic rates, particularly with the M16E1 rifle and Stoner machinegun. Surging also was most noticeable with the Stoner machinegun. It is concluded that this excessive cyclic rate (through induced cyclic and impact problems) caused, complicated, and multiplied such malfunctions as failures of the bolt to remain to the rear after the last round was fired from the magazine, failures to eject, and magazine feeding problems.

A concurrent propellant investigation by Frankford Arsenal showed that the propellant currently used in the 5.56mm ball cartridge cycles weapons faster than the original propellant.

¹⁸ Emphasis added.

Inquiry to AMC determined that, to meet a government acceptance requirement, M16E1 rifles are calibrated at the factory for the gas port pressure of the original propellant rather than that of the propellant currently used in standard ball 5.56mm cartridges. Interaction of the higher gas port pressure of the current propellant and the sizing of the gas port for a propellant with a lower gas port pressure is considered the reason for the excessive cyclic rate in the M16E1 rifle.

Buffer modification

The Army's response to these reported malfunctions associated with the 5.56-mm. ammunition was to design a heavier buffer to slow down the cyclic rate of the weapon. The buffer modification was approved by the members of the Technical Coordinating Committee as early as January 1966; however, it was not incorporated into the rifle production line until December 1966, 11 months later. No evidence was presented to the subcommittee that any attempt was made to improve or correct the undesirable characteristics of the ammunition loaded with ball propellant, even though Frankford Arsenal was instructed on March 29, 1966, to continue to investigate the problems caused by ball propellant and determine what changes to the ammunition purchase description could be made to define acceptable performance with ball as well as IMR propellant. To this date, ammunition loaded with ball propellant still is being procured in large quantities, and millions of rounds of this ammunition are in the inventory of the services both in the United States and South Vietnam.

Ammunition deficiencies called to attention of DOD

The problems experienced with the M-16 rifle and the ammunition loaded with ball powder came to the attention of Dr. Wilbur B. Payne, Chief, Office of Operations Research in the Office of the Secretary of the Army, in November 1965. After analyzing the problem, Dr. Payne submitted a memorandum to his counterpart in the Department of Defense expressing his concern over the problem and the possibilities that the same problems might exist in Vietnam. He stated there was reason to question the wisdom of some of the earlier technical decisions on the standardization and acceptance test procedures. The first indication of a possible problem reportedly came from conversations with the rifle project manager.

Dr. Payne indicated in his memorandum that "at least two of the problems seem to be important enough to warrant further investigation and corrective action if they are verified. They are as follows: (a) the choice of ball powder in the 5.56 ammunition; (b) primer sensitivity."

As to the choice of ball powder, he stated that the decision did not derive from any evidence that increased effectiveness could be expected and that there was no record of subsequent engineering tests comparing ball powder with IMR.

Dr. Payne in his memorandum further stated:

The symptoms of trouble reported from the SAWS test are as follows: (a) the cyclic rate of the weapons is much higher (200 rounds per minute) than in acceptance test or previous engineering test; (b) excessive parts breakage; (c) excessive fouling leading to excessive failures after about 300 to 400 rounds.

He concluded by writing:

I think it is clear that if these faults are present, it is not only important to the SAWS program, it is quite probable that the same problems exist in Vietnam.

The adverse effect of the ball powder in the 5.56-mm ammunition was confirmed in a subsequent test conducted by Frankford Arsenal; however, no action was taken to recall any ammunition loaded with ball powder, or to remove it from the qualified list of ammunition as was done with IMR 4475 when it failed to meet the velocity/pressure specification.

Army witnesses before the subcommittee testified that there was no relationship between malfunction of the M-16 as experienced in Vietnam and the excessive fouling demonstrated in the SAWS program.

It is the opinion of the subcommittee that the question of excessive fouling being associated with excessive malfunctions of the rifle has not received an adequate test and evaluation. Until this theory is adequately proved or disproved, the subcommittee is convinced that there is a direct relationship between the two. Obviously, excessive fouling requires more intensive and more frequent cleaning.

One of the modifications proposed by the Army to reduce malfunctions is the chrome plating of the barrel chamber. This will simplify the cleaning of the chamber and reduce pitting within the chamber; however, it will have no effect on the carbon build-up on the working parts of the rifle caused by the fouling characteristics of ball powder.

In the final report on the Army Small Arms Weapons Systems study (SAWS study) dated August 30, 1966, the Army Test and Evaluation Command of Combat Developments Command concluded that, "The relatively low level of functional reliability of the XM16E1 rifle in these tests is not considered representative of the normal performance which can be expected from this weapon, which has been demonstrated in past tests, but is considered to indicate a need for improvement in quality control, in weapon manufacture, and for investigation of the effect of ammunition upon weapon functioning."¹⁹

Based upon the results of a field experiment, the U.S. Army Combat Development Company Experimentation Command concluded, among other things, that "The standard 5.56-mm. ammunition provided for the experiment is not satisfactory because of fouling characteristics, the pressure mismatch of propellants in the ball and tracer cartridges, and primer sensitivity." However, it was stated that these "ammunition deficiencies are judged readily correctable."

Malfunctions related to ammunition

As early as March 1964, the problem of excessive cyclic rates when using ball propellant was called to the attention of the Technical Coordinating Committee by the rifle contractor when he cited his experience on the acceptance tests when using both ball and IMR propellant. It was pointed out that of 10 weapons tested, six exceeded the upper limit of a cyclic rate test for acceptance when firing ball propellant, whereas one of 10 tested exceeded the cyclic rate when using IMR propellant. At that time, the contractor requested, and the Technical Coordinating Committee approved, a waiver of the upper cyclic rate limit for acceptance purposes of those rifles delivered in April. Subsequently, it was necessary to extend the waiver for the months of May, June, and July. After that time, the contractor used only IMR propellants for the cyclic rate test, thereby qualifying the rifles for delivery to the Army.

¹⁹ Emphasis added.

The relationship between high cyclic rates and ball propellant ammunition was again called to the attention of Army officials in June 1965 by Colt's and in November 1965 by a test report submitted by Colt's citing the exceedingly high cyclic rate when using ball propellant for test acceptance purposes. In view of their favorable experience in 1964 in obtaining a waiver in this area, Colt again suggested raising the upper cyclic rate limit by 150 rounds per minute to accommodate both IMR and ball propellant ammunition. Colt's test concluded that for weapons such as those used in their experiment, none are likely to fail with IMR, whereas more than one-half are likely to fail with ball ammunition. This report also pointed out that fatigue failures of the bolt are somewhat more frequent when the cyclic rate of fire is significantly increased.

Colt's reported there are also certain malfunctions which occur more frequently when the timing of the gun cycle is materially speeded up. Especially there is increased frequency of the failure of the bolt catch to arrest the bolt after firing the last round in a magazine.

This relationship of ball propellant ammunition and excessive cyclic rates and broken parts was also confirmed in the early reports from the test agencies participating in the SAWS study, in particular the reports from the Combat Developments Command Experimentation Center at Fort Ord, Calif. The relationship was further confirmed by tests conducted at Frankford Arsenal in December 1965²⁰ as well as later reports from Colt's in January and March of 1966.

Another cause of malfunctions was called to the Army's attention in the same March 1964 meeting of the Technical Coordinating Committee when it was reported that ammunition utilized in acceptance testing at Colt's had exhibited various degrees of fouling characteristics. It was stated that in certain lots several thousand rounds may be fired from weapons (without cleaning) without any evidence of malfunction due to fouling. In other lots, stoppages occurred due to fouling in as little as 500 to 600 rounds.

The subcommittee notes that at that point in time, March 1964, the ammunition specification failed to include restrictions against fouling caused by the ammunition. Subsequently the specification was amended to include a 1,000 round fouling test to be successfully conducted on each preproduction lot as a condition of acceptance. This requirement applies only to the preproduction lot as a condition of acceptance and not to follow-on production quantities. However, as pointed out to the subcommittee, unless close quality control is maintained in the loading of each lot of cartridges, the chemical composition and performance characteristics can differ. It is inconceivable that the Army would accept as many as 59 million cartridges on the basis of testing only one preproduction lot.

QUALITY ASSURANCE

Prior to the receipt by Colt's of the first Army contract on November 4, 1963, Colt's had no formal detailed quality assurance procedures for the inspection of AR-15 rifles, including those sold to the U.S.

²⁰ The test report was dated February 1966. It pointed out that the malfunction and stoppage rates per 1,000 rounds were 18.5 and 5.2, respectively, when firing ammunition loaded with ball propellant versus 3.2 and 0.75, respectively when firing ammunition loaded with IMR propellant.

Air Force. The Army contract, however, contained requirements for a quality assurance program which Colt's was required to submit to the Government for approval. Representatives of Springfield Armory, Boston Procurement District, and Army Weapons Command, assisted Colt's personnel in preparing a quality assurance program which the Army approved on February 7, 1964.

Reports prepared by Army Weapons Command personnel in connection with their periodic surveillance of Colt's quality assurance program indicate that during 1964 Colt's experienced certain difficulties in implementing the approved quality assurance program. These difficulties ranged from failing to coat all metallic surfaces with preservative oil after cleaning the rifle to an uneven flow of material, resulting in rush and jamups toward the end of the month in an effort to meet commitments. It wasn't until February 1965 that Colt's quality assurance program was concluded to be generally satisfactory in operation and conformance. During the balance of 1965 and through 1966, Colt's received satisfactory ratings from the Springfield Armory teams who periodically reviewed their quality assurance program.

Generally, the quality assurance procedures at Colt's now consist of both visual and functional examinations of all raw materials, purchased parts and parts manufactured by Colt's for the M-16 rifle as well as finished products, that is, rifles and spare parts. Visual examinations include the inspector's insuring that the proper type or quantity of gages are at each work station and insuring that the proper operation tags are attached to the various machines. Examples of functional examinations include the inspector's witnessing rifles fired for target and accuracy and the inspector's changing of parts in rifles to insure interchangeability.

At the request of the subcommittee, General Accounting Office representatives made a limited review of Colt's quality assurance program currently in effect and found no instances where the contractor was not properly following the approved program.

The Government supervisory inspector at Colt's plant, Mr. Christo W. Kantany, appeared as a witness before the subcommittee. Mr. Kantany testified that the current quality assurance procedures at Colt's production and assembly facilities are adequate. However, he recommended returning to the previous function firing test of 40 rounds, compared to the present practice of firing only 20 rounds.

Another suggestion made by Mr. Kantany was to take a large sample of production rifles, "say 500 to 1,000," and fire each of these weapons 200 to 300 rounds apiece. In this manner one can readily determine what the problems are with the M-16 rifle.

Mr. Kantany also testified that he did not receive any instructions from anyone to tighten inspection procedures when reports of excessive malfunctions were received from Vietnam. He took the initiative upon reading newspaper accounts of the problems in March or April, some 6 months or more after reports were submitted to the Army Materiel Command and the rifle project manager. Mr. Kantany tightened the inspection procedure on the chamber of the barrel. He testified that out of a 50-barrel sample, 12 were defective. This was said to be higher rejects than normally experienced under quality control standards.

Mr. Kantany is to be commended for taking the initiative in this vital area of responsibility.

With respect to the question of the possible connection between rifle malfunctions and proper lubrication, the subcommittee views with concern the following facts:

1. After months of unequivocally defending the authorized rifle and small arms lubricant (known as VV-L-800 or PL Special) being issued in Vietnam, the Army has acknowledged in its report dated June 1967, that a better lubricant for the difficult environmental conditions of Vietnam has existed in the inventory since 1959, and since late May has been rushing it out to the troops.

2. The special qualities of this purportedly superior lubricant (known as MIL-L-46000A) became known to the Army, according to its own account, as the result of tests designed specifically to weigh the claims of a commercial, molybdenum disulfide base lubricant (known as Dri-Slide), which has won considerable acclaim from many of the troops in Vietnam who have procured it by mail order at their own expense and inconvenience. Without such outside stimulus there is no indication as to when the Army would have reviewed the lubricating qualities of MIL-L-46000A and considered making it available for use in Vietnam.

3. As a further result of this special Army test it was discovered that the official rifle maintenance instructions were improper in that the lubricant was required to be sparingly applied to certain parts of the M-16; and revised instructions prescribing liberal lubrication have been issued as of June 2, 1967.

4. In 1966 the Marine Corps tested, approved, and procured approximately 100,000 units of Dri-Slide as a supplemental lubricant for use in Vietnam along with the authorized lubricant (VV-1-800). According to testimony before the subcommittee on May 16, Marine Corps spokesmen reported that the troop response to Dri-Slide was "very enthusiastic" and that they were in the process of reordering this type of lubricant. It was also stated that a test was being made of the new Army lubricant MIL-L-46000A. In a memorandum dated July 24, 1967, the Commandant of the Marine Corps announced, in releasing the final report of this test that:

a. Mil-L-46000A would replace VV-L-800 as the "standard general purpose lubricant for all small arms."

b. Contrary to the findings of the test and the recommendation of the testing facility, the supplemental lubricant (Dri-Slide) would not be retained in the supply system.

In testimony before the subcommittee on August 8-9, this test, which was identical in scope to the one conducted in 1966, was acknowledged by Marine Corps representatives to have shown that Dri-Slide was "significantly more effective" under dry, sandy conditions and "equally effective" as MIL-L-46000A on the M-16 and M-16A1 rifles under muddy water conditions. However, when questioned as to why the Marine Corps did not accept the results of its own test, the witness disclosed that certain test findings were subsequently rejected on the basis of a further analysis ordered by the Marine Corps. Upon request a copy of this analysis was submitted for the record and the document bears the date of June 30, 1967. Since the final test report dated July 24, 1967, contains no reference to such an analysis or any suggestion that the test was invalid in any way, the subcommittee can only conclude that it

was misled by the witness when told that further analysis had caused the Marine Corps to reject the results of its own test. To compound matters, this same Marine Corps analysis, it was learned after study, raised questions about the 1967 Army lubricant test as well.

Therefore, in view of the confused, uncoordinated, crisis-oriented, self-protective manner which has characterized all too much the handling of the matter of rifle lubrication, so vital to the welfare of the foot soldier in the field, the subcommittee recommends that:

The Secretary of Defense—

a. Authorize an independent research facility to conduct a thorough analysis of the tests procedures of the various services to ascertain their reliability; and to conduct such additional tests of such lubricants as are found necessary to clearly establish their effectiveness as lubricants under various conditions.

b. Initiate efforts to improve coordination among the services to insure an orderly, continuous research and development program in the field of weapons lubricants; and to report to the committee the steps he has undertaken to accomplish this.

M-16 TRAINING PUBLICATIONS

At the present time the two major publications providing training and maintenance instructions on the M-16 rifle are the Army field manual FM23-9, and a technical manual TM-9-1005-249-14. An examination of the manuals indicates unnecessary duplication on one hand, while providing a lack of information and instructions on another. For instance, the field manual fails to contain adequate instruction on stoppages and actions for correction. Also, certain training publications appear to provide misleading instructions in that the language tends to oversell the reliability of the rifle.

Examples of this language are as follows:

This weapon requires the least maintenance of any type weapon within the Army arsenal today.

This rifle will fire longer without cleaning or oiling than any other known rifle. An occasional cleaning will keep the weapon functioning indefinitely.

Working parts can be cleaned by wiping with a clean cloth.

The recent experience in Vietnam tends to refute the above statements. In fact, military personnel are now instructed to provide what some consider to be an excessive amount of care and cleaning of the weapon.

Consideration should be given to consolidating into one publication the field and technical manuals to provide consistency of information and a lack of duplication.

Training instructions at all levels should emphasize the proper care and cleaning of the rifle in view of the characteristics of the ammunition utilized.

FOREIGN SALES

Since the AR-15 rifle has been in production by Colt's Inc., approximately 55 foreign countries have procured or accepted small quantities for test and evaluation. Two exceptions from the standpoint of quantity are England and Singapore. In these two instances, England received 5,000 rifles in 1965 and Singapore is to receive 20,300 during 1967 and 1968.

In addition, the Army has supplied substantial quantities of M-16A1 rifles to our allies fighting in Southeast Asia.

The one sale causing the subcommittee to be greatly concerned was that of 20,300 rifles to Singapore. The concern was not one of fear that the weapons would fall into unfriendly hands or that the security forces of Singapore should not be equipped with a modern and efficient weapon, but whether or not the U.S. inventory of this weapon was sufficient to provide the quantities needed for our fighting forces in South Vietnam, including United States and allies. In addition there existed at the time of the approval of the Singapore sale an unfulfilled requirement for M-16 rifles for training of U.S. military personnel prior to their deployment to Southeast Asia and for equipping support units in Southeast Asia.

State Department witnesses admitted in testimony that someone "goofed" in failing to obtain proper approval from the Department of Defense prior to issuing the export license. Subsequent to that instance the coordinating instructions have been reemphasized and now require approval of the military department involved prior to the issuances of export license for weapons.

POSSIBLE CONFLICT OF INTEREST

Maj. Gen. Nelson M. Lynde, Jr., U.S. Army, retired, was commanding general of the Army Weapons Command from May 16, 1962, until February 29, 1964, the date of his retirement. From March 1963, at which time the Technical Coordinating Committee was established and Lt. Col. Harold W. Yount was designated rifle project manager under the Army Weapons Command which reported to the Army Material Command, General Lynde's Command was directly involved in the negotiations for procurement of the M-16 rifle. General Lynde testified that he was responsible for the development, procurement, and field service support of Army weapons.

As previously mentioned in the report, General Lynde on October 4, 1963, is recorded as approving the prices as negotiated and directed the preparation of approval of award for submission to higher authority.

On October 31, 1963, 4 days before the award of the initial letter contract for production of 104,000 rifles for the Army and the Air Force, General Lynde appointed his deputy, Brig. Gen. Roland B. Anderson, as the contracting officer on the one-time basis to permit the award of the contract to the Colt's Patent Firearms Manufacturing Co. He stated that his reason for the appointment was that he would be absent from the command at the time of the contract award.

General Lynde retired from the Army on March 1, 1964. Two days before his retirement he sought an opinion of the Army Adjutant General regarding an offer of employment from the Fairbanks Whitney Corp., the parent company to Colt's. He indicated in his letter to the Adjutant General that he was the head of the procurement activity as commanding general of the U.S. Army Weapons Command during the negotiation, evaluation, and recommendation for award and award of Contract DA-11-199-AMC-508 (Y). He also indicated that the "proposed employment does not contemplate, nor would I, of course, engage in any activity with regards to the M-16 rifle where the U.S. Government might be directly involved." He indicated further that the offer must be accepted on or before March 15, 1964.

The Adjutant General's letter of reply was dated March 5, 1964. It is as follows:

Your letter indicates that you will be employed by the Fairbanks Whitney Corporation as an executive consultant accountable to the president for professional and technical guidance to the Corporation and/or its subsidiaries, in planning for new products for the future and in evaluating current product or projects, particularly in the area of military weapons. It does not appear from the position description submitted with your letter that your duties will require you to sell any property or service to the United States. If these conclusions are correct, then your employment will not be contrary to any pertinent laws or regulations.

Since it appears that you were involved in munitions procurement activities while on active duty, you should bear in mind while carrying out the duties fixed by your private employment that you remain subject to the restrictions fixed by title 18, United State Code, section 207. Section 207 (a) permanently prohibits retired Regular Army officers from knowingly acting as agents or attorney for anyone other than the United States in connection with any proceeding, application, contract, request for a ruling, or other particular matter involving a specific party or parties, in which the United States is a party or has a direct and substantial interest, and in which they participated personally and substantially while on active duty. Section 207 (b) of the same title bars retired Regular Army officers, for one year after retirement from appearing personally as agent or attorney before any court or agency of the government for anyone other than the United States in connection with any proceedings, application, contract, or other particular matter involving a specific party or parties in which the United States is a party or directly and substantially interested, and which was under his official responsibility as an officer within one year prior to retirement.

You are advised that the foregoing is advisory only, as the interpretation and enforcement of Federal statutes are matters for final determination by the Department of Justice and the Federal Courts.

General Accounting Office personnel assisting the subcommittee in obtaining information on the M-16 procurement program were advised by Colt's officials that their records showed that General Lynde was hired as an executive consultant on August 1, 1964.

General Lynde testified before the subcommittee that he was employed by Fairbanks Whitney, now Colt Industries, Inc., on August 3, 1964, and since his employment he had refrained from association with the M-16.

The General Accounting Office inquiry also disclosed a letter dated October 26, 1964, signed by General Lynde, as a retired general, to the U.S. Army procurement district requesting copies of four classified documents including one entitled "Comparative Effectiveness Evaluation of the AR-15, M-14."

The records at Colt's also reveal General Lynde's name appearing on the distribution list for many intercompany memorandums involving the M-16.

Without passing judgment on the legality of General Lynde's activities since becoming associated with the company producing a rifle contracted for by his immediate command while he was on active duty, the subcommittee does seriously question the wisdom of such action in view of the suspicion aroused by this type of association. It is actions such as these that cause the American taxpayer to lose faith in the integrity of both military and civilian officials associated with the expenditure of millions of dollars yearly in the procurement of supplies and material to meet our military requirements.

Several discrepancies are noted between the testimony of General Lynde and the facts obtained by the subcommittee:

1. Chairman Ichord questioned General Lynde: "Did you approve the 1963 procurement contract of the M-16 rifles from Colt, Inc.?" His reply was that he "appointed Brig. Gen. Roland B. Anderson as a contracting officer on a one-time basis to permit the award of contract."

The record shows that General Lynde, as Commanding General of the Army Weapons Command, *approved the prices negotiated* and directed the preparation of approval of award for submission to higher authority. The mere fact that he did not sign the contract as contracting officer does not mean that he did not participate in the negotiations right up to the eve of contract award.

2. General Lynde testified and stated in his letter to the Adjutant General that he did not or would not engage in any activity with regard to the M-16 rifle where the U.S. Government would be directly involved, yet the record shows that on October 26, 1964, he requested from the U.S. Army a classified document which compared the effectiveness of the AR-15 with the M-14 rifle;

3. In spite of his assertion of no interest in the M-16 rifle activities, his name appears on distribution lists for intercompany memorandums involving the M-16 rifle; and

4. The delay of 5 months between his retirement from the Army and his employment by the M-16 rifle producer would appear not to constitute a sufficient cooling-off period in view of the fact that the employment offer was made before his date of retirement and, by his own admission, had to be accepted on or before March 15, 1964, 2 weeks after his retirement date.

ROYALTIES

In accordance with a license and technical assistance agreement dated January 7, 1959, Colt's acquired from Hiller Corp., Hagerstown, Md. (formerly Fairchild-Stratos Corp., and Fairchild Engineering & Airplane Corp.) the rights and licenses to make, to use and to sell the AR-15 rifle in the United States and elsewhere in the world. As a consideration for the rights and licenses Colt agreed to pay Fairchild certain royalties as provided for in the agreement and a lump sum payment of \$75,000. The agreement also committed Colt to the payment of royalties on all spare or replacement parts and components manufactured and sold by Colt.

Cooper-Macdonald, Inc., Baltimore, Md., an authorized representative of Colt for the sale of various Colt products throughout the world, was instrumental in consummating the agreement between Colt and Fairchild. For its efforts in securing this agreement, Cooper-Macdonald obtained a fixed sum of \$250,000 as a "finders fee" and a commission of 1 percent of the selling price of each rifle, spare parts, and accessories.

Colt, according to its various agreements with Fairchild, is obligated to pay royalties on the selling price of weapons (rifles) and spare parts sold for military and commercial use. The current agreement between Colt and Fairchild, dated April 1, 1963, grants Colt an exclusive right and license to make, use, and sell weapons (rifles) and spare parts in the United States territory and to sell such weapons and spare parts throughout the world. Included in the agreement is a provision which requires Colt to pay the following:

- (a) To Domestic Licensor:
 - (i) a royalty of four and one-half percent (4½%) of the Selling Price of Weapons and Spare Parts manufactured and Sold by Licensee in the United States Territory or as otherwise permitted by Section 3(a), for military use;
 - (ii) a royalty at the following percentages of the Selling Price of Weapons and Spare Parts manufactured and Sold by Licensee in the United States Territory or as otherwise permitted by Section 3(a) for Commercial Use during each calendar year:
 - Five percent (5%) of the first \$200,000 of sales of Weapons and Spare Parts;
 - Four and one-half percent (4½%) of any amount of such sales excess of \$200,000;
- (b) Only to Foreign Licensor:
 - (i) a royalty of four and one-half percent (4½%) of the Selling Price of Weapons and Spare Parts manufactured and sold by Licensee as permitted by Section 3(b), for Military Use or Commercial Use.

In the event a sublicense is granted by Colt the agreement subjects Colt under domestic patent rights to a royalty arrangement of not less than 3 percent of the selling price of weapons and spare parts for military use. On commercial sales the royalty payments decrease from a high of 5 percent to a low of 3 percent as sales increase. Any foreign sublicense granted by Colt requires royalty rates of not less than 4 percent of the selling price of weapons and spare parts.

During the period July 1960 through the first quarter 1967; Colt's royalty payments to Fairchild totaled \$2,628,283 based on military and commercial sales of rifles and parts. Of this amount, \$2,339,651 represented payments on military sales.

ACTIONS TAKEN SUBSEQUENT TO SUBCOMMITTEE'S INQUIRY

Marine Corps witnesses testified that subsequent to the subcommittee's visit to Vietnam, the Commanding General, III Marine Amphibious Force, established an orientation team for the M-16 rifle. The team visited every Marine unit explaining the problems experienced and the measures which must be taken to get the most out of the M-16 weapon. In a later submission of information for the record, the Marine Corps reported as follows:

In addition to the visit of the Orientation Team, the following actions have been taken since the subcommittee visit to Vietnam.

- a. Commanding General, III Marine Amphibious Force, has formed a contact team of M16A1 experts from the Force Logistic Command. This team has been tasked with the mission of visiting M16A1-using units and training similar teams. The Unit Teams, in turn, will conduct a technical inspection of each M16A1 rifle, provide instruction on care and cleaning, and supervise test firing of each weapon to insure proper weapon functioning. (Copy of message establishing and directing team activities is attached.)
- b. Interim instructions were promulgated on 4 August 1967 for the use of lube oil, semi-fluid MIL-L-46000A with the M16A1 rifle in lieu of lube oil general purpose (PL Special) and rifle grease (9150-754-0063). The interim instructions will be used pending receipt of III MAF of Marine Corps Supply instructions. (Copy of interim instruction attached.)
- c. Articles have been published in the June 1967, July 1967, and August 1967 "Tactical Trends and Training Tips" regarding care, cleaning, and use of the M16A1. The August 1967 article was printed to provide for removal from the publication and separate retention. (Copies attached.)
- d. A Force Bulletin on the M16A1 was promulgated on 16 June 1967. The bulletin contains special instructions for care, cleaning, and correction of common malfunctions of the M16A1. (Copy attached.)
- e. Copies of USARV pamphlet 750-5 of 14 December 1966 have been distributed to each Marine armed with the M16A1.

f. Copies of a pocket/wallet sized card with instructions regarding care and cleaning of the M16A1 are being provided for distribution to each Marine armed with the weapon.

On the problem of cleaning equipment, Chairman Ichord asked Brig. Gen. Gordon D. Gayle, Deputy Assistant Chief of Staff, G-3, Headquarters, U.S. Marine Corps, "What, if anything, after the committee visit, was done to assure that every man using the M-16 rifle has the necessary cleaning equipment, particularly a cleaning rod and chamber and bore brushes?"

The reply was that the Marines have instituted "Operation M-16" where cleaning equipment has been airlifted to our forces in Vietnam. Also, it is reported that accelerated procurement of additional quantities of cleaning equipment is underway to cope with the unexpected utilization of equipment being approximately three times the expected rate.

The actions taken by the Army are reported elsewhere in the report. The Deputy Secretary of Defense, the Honorable Paul Nitze, on July 31, 1967, issued a memorandum directing a technical evaluation and field survey of the performance of the M-16 rifle. The purpose of the survey and evaluation was stated to be "to determine whether any major deficiencies exist in the weapon, and, if so, to recommend corrective action."

To conduct the technical evaluation, the Director of Defense Research and Engineering, with the assistance of the Assistant Secretary of Defense (I. & L.) and the Assistant Secretaries for Research and Development of the military departments, was requested to compile and analyze existing data available in continental United States and determine the following:

1. How does the M-16 rifle perform under a variety of circumstances, i.e., environmental, level of training, modes of fire?
2. Considering its mode of employment, what should be the standards of performance and reliability for the M-16 rifle?
3. What have been the causes of malfunction in the M-16 rifle; what has been or is being done to improve the weapon's reliability; and what further can be done?

In addition, the Assistant Secretary of Defense (Administration) was requested to conduct a field survey of the M-16 rifle in South Vietnam. He was instructed to "ascertain the degree to which corrective actions to eliminate causes of M-16 malfunction have been implemented; and general performance and acceptability of the M-16 rifle in the field; and general performance and acceptability of the M-16 rifle under combat conditions."

A final report together with appropriate recommendations was requested to be submitted no later than October 15, 1967.

FINDINGS AND RECOMMENDATIONS

Based on our extensive review the subcommittee's findings and recommendations are as follows:

1. That both Army and Marine Corps personnel have experienced serious and excessive malfunctions with the M-16 rifle, the most serious being the failure to extract the spent cartridge.
2. That proper care and cleaning are of the utmost importance to the effective operation of the rifle.

3. That shortages of cleaning equipment, lack of proper training and instructions contributed to the excessive malfunction rate of the M-16 rifle in Vietnam.

4. That various levels of command in both the Army and the Marine Corps have been negligent in failing to provide proper supervision in the care and cleaning of the rifle, as well as failing to distribute cleaning material and written instructions.

5. That the past experience of the Army with the M-16 rifle in Vietnam was not properly called to the attention of the Marines when the weapon was issued to them in Vietnam.

6. That the major contributor to malfunctions experienced in Vietnam was ammunition loaded with ball propellant.

7. That the change from IMR extruded powder to ball propellant in 1964 for 5.56-mm. ammunition was not justified or supported by test data.

8. That the sole-source position enjoyed by Olin Mathieson on ball propellants for many years and their close relationship with the Army may have influenced the decisionmakers at Army Munitions Command, Army Weapons Command, and the Army Materiel Command. The House Armed Services Committee repeatedly has cautioned the military departments against sole-source procurements. *Therefore, it is recommended that the General Accounting Office conduct an audit and investigation of the contracts awarded to Olin Mathieson for ball propellant loaded in both 5.56-mm. and 7.62-mm. ammunition and the justification for sole-source procurement over the past 26 years.*

9. That a number of modifications to the M-16 rifle were made necessary only after ball propellant was adopted for 5.56-mm. ammunition.

10. That the AR-15/M-16 rifle as initially developed was an excellent and reliable weapon.

11. That certain modifications made to the rifle at the insistence of the Army were unnecessary and were not supported by test data.

12. That two of these modifications increased the unit cost of the rifle substantially and another decreased its performance characteristics. These modifications were the bolt closure device, chrome plating of the barrel chamber, and the change in barrel twist.

13. That corrective action on deficiencies reported and product improvement of the weapon have been unnecessarily delayed.

14. A sole source of production of both the ball propellant and the M-16 rifle have contributed to the delay in product improvement and the corrective action required.

15. That officials in the Department of the Army were aware of the adverse effect of ball propellant on the cyclic rate of the M-16 rifle as early as March 1964, when it was brought to the attention of the Technical Coordinating Committee, yet continued to accept delivery of additional thousands of rifles that were not subjected to acceptance or endurance tests using the ammunition of greatest density in the field and in the supply system (ball-propellant-loaded ammunition). Up to September 1966, about 99 million rounds of 5.56-mm. ammunition were consumed in Vietnam, of which 89 million rounds were loaded with ball propellant.

16. That the rifle project manager, the administrative contracting officer, the members of the Technical Coordinating Committee, and

others as high in authority as the Assistant Secretary of Defense for Installations and Logistics knowingly accepted M-16 rifles that would not pass the approved acceptance test. Colt's officials advised the Army that more than half of the rifles would not pass the acceptance test on cyclic rate if they were made to use both ball propellant and IMR extruded propellant in their testing procedure. Colt's was allowed to test using only IMR propellant at a time when the vast majority of ammunition in the field, including Vietnam, was loaded with ball propellant.

17. That the failure on the part of officials with authority in the Army to cause action to be taken to correct the deficiencies of the 5.56-mm. ammunition borders on criminal negligence.

18. That there still is no proof that the modifications proposed will eliminate the malfunctions experienced with the M-16 in Vietnam. *It is recommended that the Department of Defense direct and expedite a thorough and objective test by an independent organization of the weapon system consisting of the modified rifle and the ammunition in Vietnam, as well as both types of propellant currently being loaded in 5.56-mm. ammunition.*

19. That the fouling characteristics of ball propellant will require continued emphasis on proper care and cleaning of the M-16 rifle. Carbon deposit buildup will continue to pose a problem for the extractor, various parts of the bolt mechanism, bolt carrier key, the gas port, and possibly other areas in both the upper and lower receiver.

20. That there is a possible pressure mismatch between tracer and regular ball ammunition that could cause the rifle not to operate properly.

21. That there was a shortage of M-16 rifles for training purposes both in the United States and Vietnam at the time of the approval of the sale of 20,300 rifles to Singapore.

22. That there was a lack of proper coordination between the State and Defense Departments on the sale of the rifles to Singapore.

23. That no instructions regarding tightening of production quality controls were issued by the rifle project manager, Army Materiel Command, or anyone in high authority after continued reports of malfunctions were received from Vietnam.

The Government inspector at Colt's plant took the initiative only after reading newspaper reports of problems being experienced. These newspaper reports were not published until about 6 months after notices of excessive malfunctions were received by the rifle project manager and the Army Materiel Command.

The only inspection tightened as a result of these adverse reports was the one on barrel chambers. This tightened inspection revealed an excessive number failed to meet specifications. *It is difficult for the subcommittee to understand why quality controls were not tightened immediately upon receipt of adverse reports from the troops in Vietnam.*

24. That the bias and prejudices of individuals associated with Army commands or agencies responsible for development and testing of new weapons made it extremely difficult for higher authority to obtain objective information upon which decisions should have been made relative to the rifle program.

25. That the Army system of development, production, and introduction of a new weapon into the inventory should be thoroughly

reviewed to determine if the rifle program is typical of the manner in which the Army operates. The manner in which the Army rifle program has been managed is unbelievable. The existing command structure was either inadequate or inoperative. The division of responsibility makes it almost impossible to pinpoint responsibility when mistakes are made. There is substantial evidence of lack of activity on the part of responsible officials of highest authority even when the problems of the M-16 and its ammunition came to their attention. It appears that under the present system problems are too slowly recognized and reactions to problems are even slower.

The rifle project manager doesn't appear to have control over ammunition. Yet, the weapon system consists of both the rifle and ammunition. It is possible that internal politics and jealousies between the Army Weapons Command and the Army Munitions Command are roadblocks to the successful management of new weapons systems.

26. That it was at least unethical for Major General Lynde to accept employment with the producer of the M-16 rifle upon his retirement from the Army. General Lynde was commanding general of the Army Weapons Command throughout the negotiations for the first Army procurement of the M-16 rifle and in fact approved the terms of the contract negotiated by his subordinates.

27. That minimum effort was expended by the Army and the Department of Defense in attempting to acquire the production rights and technical data package for the purpose of establishing additional sources for production of the M-16 rifle.

Based on Army reports in 1962 and 1963, there was reasonable doubt that the 1963 buy was to be only a "one-time buy" for the Army. The 1966 analysis of the SAWS study and the rifle procurement plan proposed by the Army clearly indicated the need to acquire the rights and data package, yet the Army failed to complete negotiations of a contract until mid-1967. The 1965 procurement contract was amended in June 1966 to increase the quantity by an additional 300,000 rifles. The same amendment provided for negotiations to be completed on the terms for acquiring technical data and production rights not later than December 1, 1966. The negotiations were not completed until over 1 year later, June 30, 1967.

28. That both the Army and Colt's failed to negotiate in good faith in an attempt to comply with the terms of the 1965 production contract; i.e., come to terms on the rights and data package on or before December 1, 1966.

29. That this lack of action delayed the establishment of additional production sources by at least 7 months.

30. That based on information and records made available by the contractor and the Army, it appears that Colt's has enjoyed an excessive profit on M-16 production contracts to date.

Colt's has enjoyed negotiated fixed-price contracts on a 10 percent profit rate basis. Our review revealed profits of 19.6 percent for calendar year 1965; 16.8 percent for calendar year 1966; and 13.4 percent for the first 4 months of 1967. *It is recommended that the General Accounting Office conduct a complete audit of Colt's military contracts to determine actual profit rates experienced, the adequacy of their accounting system and whether provisions of Public Law 87-653 were circumvented.*

31. It is recommended that proper action be taken by the Secretary of Defense and the Secretary of the Army to insure that the design, contracting, procurement, manufacture, development, supply, and testing of future weapons not suffer the same fate.

The subcommittee recommends that the Secretary of Defense and the Secretary of the Army make adequate studies to determine if the abolishment by the Secretary of Defense of the Office of the Chief of Ordnance (which was accomplished along with the abolishment of the position of other chiefs of various Army services in 1962) could have been partly responsible for the failure of proper control and supervision in the matter of the M-16.

RICHARD H. ICHORD, *Chairman.*
SPEEDY O. LONG.
WILLIAM G. BRAY.

I have read the foregoing report and find myself in full accord with the views and recommendations of the subcommittee.

L. MENDEL RIVERS, *Chairman.*

○