

OPERATOR'S MANUAL



M16A1E1 RIFLE

CHANGE 1

PROPOSED DRAFT
TM 9-1005-249-10
OCTOBER 1981

US MARINE CORPS LIAISON OFFICER
ARRADCOM
DOVER, NJ 07801

INTRODUCTION	PAGES
TO YOUR WEAPON	2-13
AMMUNITION	9
DISASSEMBLY	14-17
LUBRICATION	22-31
ASSEMBLY	33-37
MAGAZINE	38-39
PMCS	40-41
OPERATION	42-57
TROUBLESHOOTING	58-63

WARNING

BEWARE OF DANGEROUS PROCEDURES

- * Be sure the cam pin is installed in the bolt group. If it isn't, your rifle can still fire, but it could possibly explode, causing you harm.
- * If you're using the blank ammo attachment, don't use any other ammo except the blank round, M200. (Marked on each box of 20 rounds).
- * DO NOT exchange or switch bolt assemblies from one M16A1E1 to another...It could cause damage to both you and the rifle.
- * If your rifle stops firing with a live round in the chamber of a hot barrel (misfire), remove the round fast. However, during training, if you cannot remove it within 10 seconds, wait 15 minutes with the rifle pointing in a safe direction. This way you won't get hurt by a possible ammo cook-off, which could happen 10 seconds after contact with a hot chamber. Regardless, keep your face away from the ejection port while clearing a hot chamber.
- * Use only authorized ammo that is manufactured to U.S. or NATO specifications.

- * If your bolt fails to unlock and you try to free it by banging the butt stock on the ground, keep yourself clear of the muzzle.
- * If there's water in the barrel, don't fire the rifle. It could explode.
- * If a noticeable difference in sound or recoil is experienced, STOP FIRING. Either condition could indicate an incomplete propellant burn and a bullet still in the bore. Retract bolt slowly and remove fired cartridge case. Clear weapon and check for unburned powder grains in the receiver or bore and for a bullet in the bore. Remove unburned propellant or bullet from bore before resuming firing, or barrel could explode. If bullet is lodged in bore, turn in rifle to direct support maintenance.

IF YOU GO BY ALL THE INSTRUCTIONS IN THIS BOOK, AND PERFORM PREVENTIVE MAINTENANCE (PM), YOUR M16A1E1 RIFLE WILL SHOOT, AND SHOOT AND SHOOT. IF YOU'VE DONE YOUR PART AND IT STOPS SHOOTING, TAKE YOUR M16A1E1 RIFLE TO YOUR NCO. HE HAS THE ANSWERS.

FACTS ABOUT YOUR RIFLE

The M16A1E1 rifle system consists of a rifle, one magazine and a sling. It is a lightweight, gas operated, air cooled, magazine fed, shoulder fired weapon that can be fired either in automatic 3 round bursts or semi-automatic.

Other features:

- * The barrel assembly has a fully adjustable rear sight and a compensating flash suppressor that helps keep the muzzle down during firing.
- * Upper and lower receivers are easily opened for cleaning and inspection.
- * Bolt group and barrel extension designed with locking lugs that lock bolt group to barrel extension.
- * An aluminum receiver reduces the weight of the rifle.

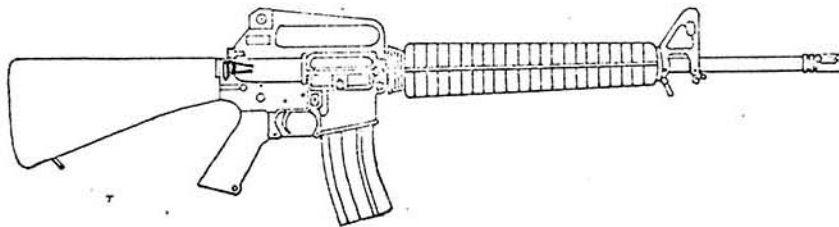

Weight:

s/30 rd mag 3.7 Kg. (8.2 lb.) approx.

Max effective rate of fire:

Semi: 45-65 rds per min

Auto: 150-200 rds per min

Max effective range:

550 meters (individual/point targets)

800 meters (area targets)

Max range:

3600 meters

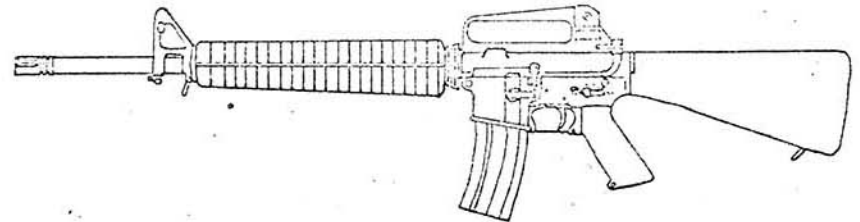

RIFLE PARTS AND WHERE THEY ARE

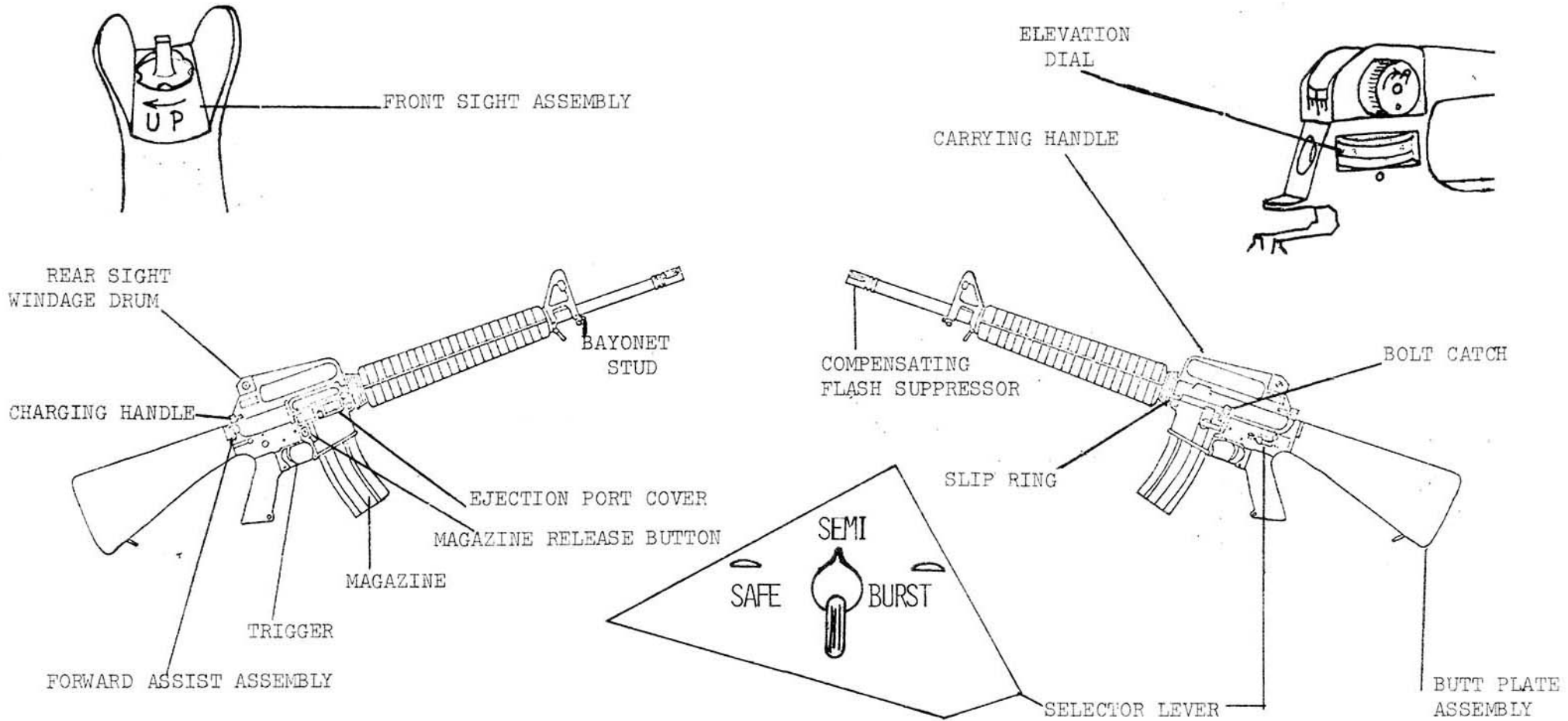

ITEMS TROOP INSTALLED OR AUTHORIZED

Items which, at the discretion of the unit CO, may accompany the M16A1 rifle but are not subject to be turned in with the rifle

Bottle Assembly, Cylindrical, LSA
or the new
Refillable, 1/2 oz.
Bottle of CLP
9150-01-102-1473



1005-00-242-5687

BORE BRUSH
1005-00-903-1296

CHAMBER BRUSH
1005-00-999-1435

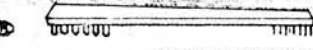

BRUSH (TOOTH)
1005-00-494-6602

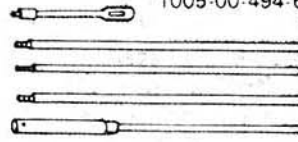

SMALL ARMS CLEANING ROD
M11E3-1005-00-089-3994



MAGAZINE ASSEMBLY
1005 00 056 2237 (20 RD)
(ISSUED UNTIL STOCK
EXHAUSTED)
1005 00 921 5004 (30 RD)

BUTTSTOCK STOWAGE ONLY



SMALL ARMS ACCESSORIES CASE
1005-00-403-5804

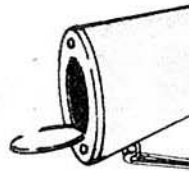

TOP SLING ADAPTER KIT

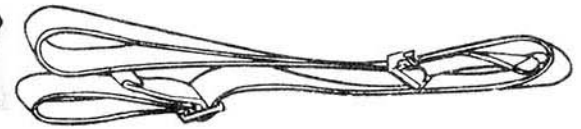

1005-00-406-1570

SLING, SMALL ARMS 1005-00-167-4336.

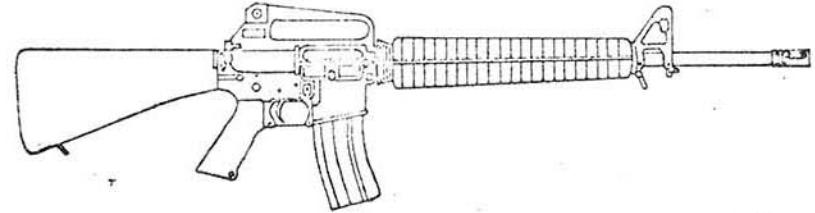

Get your MUZZLE CAP
5340-00-880-7666
MAG BAG
1005-00-052-6942 (20 RD)
1005-00-193-8306 (30 RD)

from your
UNIT SUPPLY

SCABBARD
M8A1 1095-00-508 0339

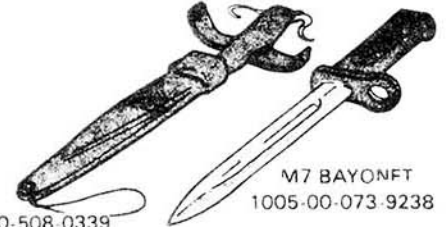

M7 BAYONET
1005-00-073-9238

M15A2 BLANK FIRING ATTACHMENT (BFA)

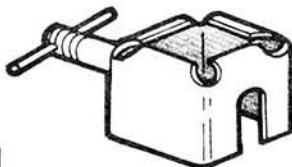

1005-00-118-6192

WARNING Use ONLY blank M200 with the BFA

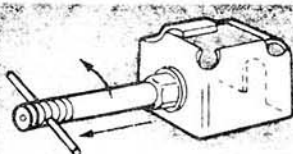

1. Unscrew and slide all the way back

2. Hook behind first groove of flash suppressor

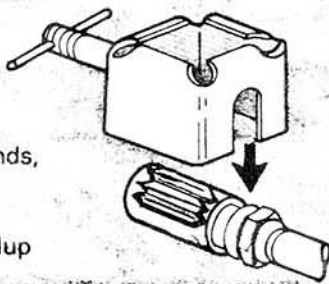

CAUTION: Do not use tools to tighten attachment, **HANDS ONLY**

3. Slide into flash suppressor and **HAND TIGHTEN**

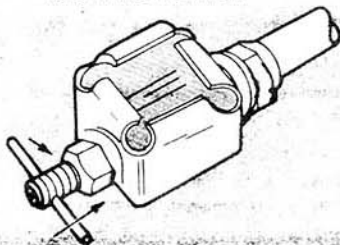

NOTE: After 50 rounds, check to see if it is still tight. Make sure to clean carbon buildup after each use

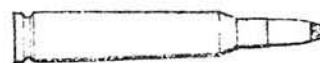

BALL, XM855E1

GREEN TIP

AMMUNITION

WARNING

DO NOT FIRE . . .

- Seriously corroded ammunition
- Dented cartridges
- Cartridges with loose bullets
- Cartridges exposed to extreme heat (135°) until they have cooled

Use only authorized ammo that is manufactured to US specs. or NATO Specs. like the new Ball, XM855E1 above.



Ball, M193

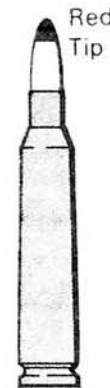

Tracer, M196



Dummy, M199



Blank, M200

**KEEP DRY, CLEAN, AND FREE OF CRUD
YOUR LIFE DEPENDS ON IT!**

USE OF SELECTOR LEVER



safe

Rifle will not fire. Selector lever cannot be on safe unless rifle is cocked. Always place in SAFE, when loading and unloading

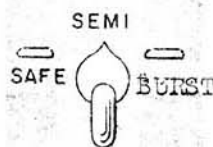

semi-automatic

Rifle will fire one round each time the trigger is pulled

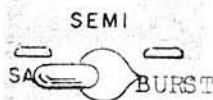

BURST

Rifle will fire a 3-round burst each time the trigger is pulled.*

CLEAR YOUR RIFLE

1 Place selector on SAFE. If weapon is not cocked, lever cannot be pointed toward SAFE.

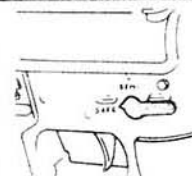

3 To lock bolt open, pull charging handle rearward, press bottom of bolt catch, allow bolt to move forward until it engages bolt catch. Return charging handle to forward. If you haven't before, place on SAFE

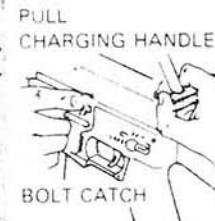

4 Eyeball receiver and chamber to insure these areas contain no ammo



2 Remove magazine



5 With selector lever pointing toward SAFE, allow bolt to go forward by pressing upper portion of bolt catch

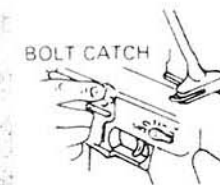

*When you first switch to BURST or begin firing after changing magazines, your first trigger pull will fire either 1, 2, or 3 rounds. But your next trigger pull will fire a full 3 rounds if that many rounds are left in the magazine. But in each case you must hold the trigger to the rear during the complete 3 round burst. If you let off on the trigger during a burst, only 1 or 2 rounds will be fired. Then your next trigger pull will only fire the remaining rounds from the previous burst. So remember, when on BURST fire, hold the trigger to the rear after you squeeze and keep holding it back until the 3 round cycle is complete

Change 1

OPERATION OF THE 3-ROUND BURST CONTROL

Your M16A1E1 has its automatic firing position limited to 3 rounds per trigger pull. This will help you save ammunition and get back on target quicker during a firefight than if the rifle kept firing as long as the trigger was held back (like a machinegun).

When you first fire your rifle on BURST, you will notice that the first trigger pull (or maybe even the last trigger pull) will not give you a full, 3-round burst. But all of the trigger pulls in between will give you a 3-round burst. So, if when you first place the selector on BURST and pull the trigger, and your rifle only fires 1 or 2 rounds, this is not a malfunction! Just quickly pull the trigger again all the way to the rear and hold. You will get a full 3-round burst. This is called "double squeezing the trigger".

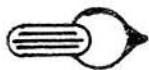

BURST rear and hold. You will get a full 3-round burst. This is called "double squeezing the trigger".

You should also follow this same "double squeezing the trigger" technique after changing magazines.

If you experience 1 or 2 round bursts after this, you are not holding the trigger to the rear long enough to allow the rifle to fire all 3 rounds. This all takes a little practice.

Remember, if you release the trigger before all 3 rounds are fired, your next pull on the trigger will only fire the remaining rounds from that previous burst. So, once you squeeze off a burst, keep the squeeze on until the 3 round cycle is complete.

SET YOUR RIFLE FOR A 3-ROUND BURST ON THE FIRST TRIGGER PULL

Three Round Burst Control: To guarantee a 3-round burst the first time you pull the trigger, follow these steps: Start with a clear weapon - (1) Place selector on BURST. (2) Pull trigger and hold it to the rear. (3) Pull charging handle to the rear and let it go 3 times. (4) Pull charging handle to rear one more time; hold it to the rear; let go the trigger; and push in the bolt lock thereby locking the bolt to the rear. Slide the charging handle all the way forward. (5) Place selector on SAFE. (6) Insert a loaded magazine and push on the other end of the bolt latch to allow the bolt to fly forward. (7) Placing the selector on BURST at this point and pulling the trigger will give you a 3-round burst.

DISASSEMBLY

first
**CLEAR
YOUR
RIFLE**

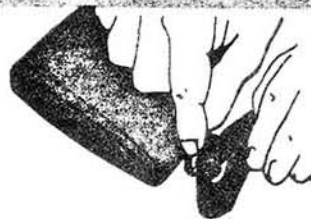

2 Remove sling

NOTE →

Remove & clean
only if dirt &
corrosion can be
seen through vent
holes

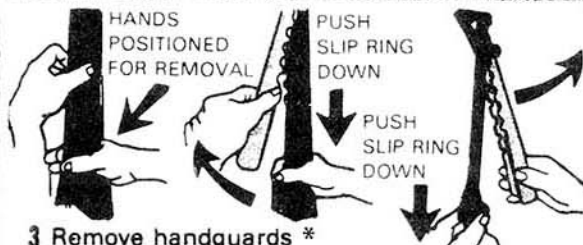

3 Remove handguards *

Push take down
pin as far as
it goes



4 Pivot upper receiver
from lower receiver

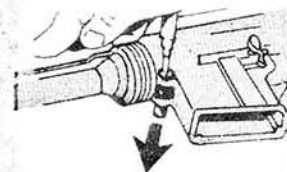

5 Push receiver
pivot pin



6 Separate upper and
lower receivers



7 Pull back
charging handle
and bolt carrier

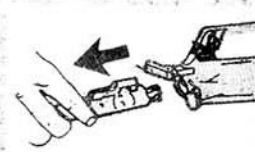

8 Remove
bolt carrier
and bolt



9 Remove charging
handle

*The round handguards are removed in the same manner except that they are removed from above and below the weapon. The round halves are identical and can be interchanged.

DISASSEMBLY cont.

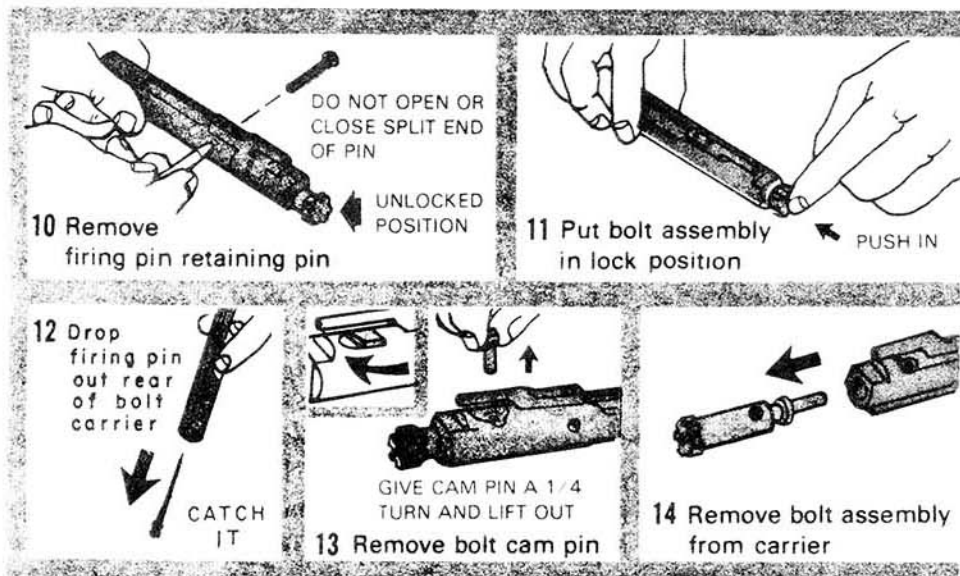

10 Remove firing pin retaining pin
DO NOT OPEN OR CLOSE SPLIT END OF PIN
UNLOCKED POSITION

11 Put bolt assembly in lock position
PUSH IN

12 Drop firing pin out rear of bolt carrier
CATCH IT

13 Remove bolt cam pin
GIVE CAM PIN A 1/4 TURN AND LIFT OUT

14 Remove bolt assembly from carrier

DISASSEMBLE STEPS 15 THRU 18 ONLY WHEN DIRTY OR DAMAGED

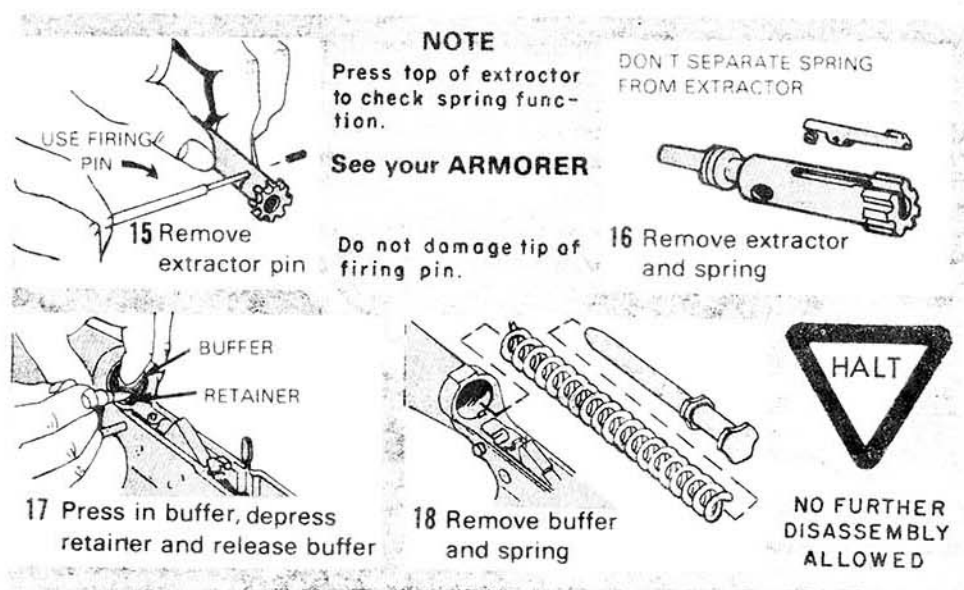

15 Remove extractor pin
USE FIRING PIN

16 Remove extractor and spring
DON'T SEPARATE SPRING FROM EXTRACTOR

17 Press in buffer, depress retainer and release buffer
BUFFER
RETAINER

18 Remove buffer and spring

NOTE
Press top of extractor to check spring function.
See your ARMORER
Do not damage tip of firing pin.

HALT
NO FURTHER DISASSEMBLY ALLOWED

BORE. The bore of your M16A1E1 has lands and grooves called rifling. This rifling makes the bullet spin very fast as it moves down the bore and on down range. This is called a "quick twist" barrel. Look down the bore and see. Because it twists so quickly, it is difficult to push a new, stiff bore brush through the bore. You will find it much easier to pull your bore brush through the bore. Also, because the brush will clean better if the bristles follow the grooves (called tracking), you want the bore brush to be allowed to turn as you pull it through. This is how you do it:

1. Swab out the bore with a wet patch.
2. Attach 3 rod sections together, but leave each one about two turns short of being tight.
3. Now attach the bore brush but leave it two turns short also.
4. With the muzzle pointed down, hold the upper receiver in one hand while inserting the end of the rod without the brush into the chamber and then let the rod fall straight through the bore. About 2-3 inches will be sticking out of the muzzle at this point.
5. Attach the handle section of the cleaning rod to the end of the rod sticking out of the muzzle.
6. Now pull the brush through the bore and out the muzzle. If you watch closely you can see the rod twisting as you pull it.
7. After one pull, take off the handle section and repeat the process. After 3 or 4 pulls you will see that the 3 rod sections and the bore brush are screwing together. Loosen them up, and repeat the process.
8. By the way, remember to send a patch through the bore once in a while to help clean out the crud that the brush is getting loose. You can use the same technique as described above to save time. Just replace the bore brush with the rod tip (patch holder) and a wet patch. Then drop it through. You won't even need to attach the handle to pull only a patch through and if you leave the rods loose again, the patch will "track" in the rifling as before. But remember, always have the bore wet with cleaner before trying to pull a brush through.

NOTE: This whole process will go quicker if you use the "buddy system" on the cleaning rods. Set one rod up with a patch holder and the other with a bore brush. Just don't mix up the parts of your rifle with those of your buddy!

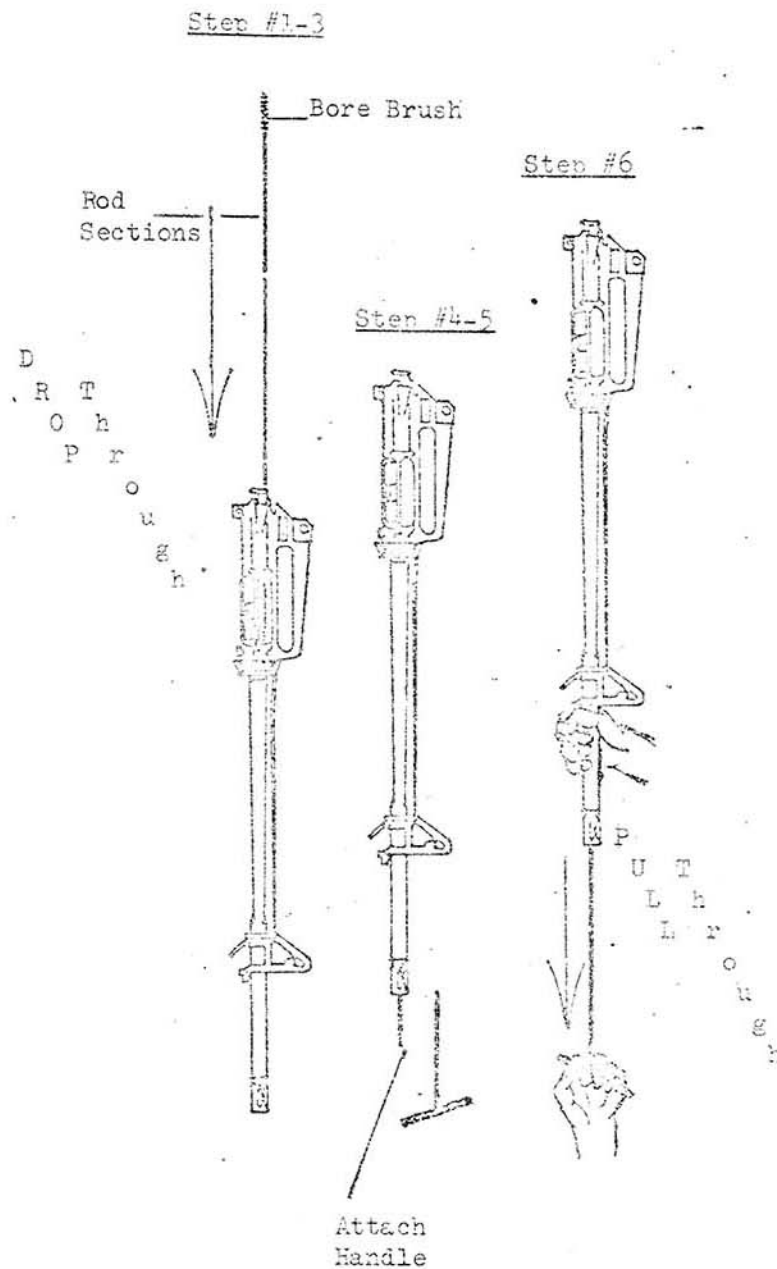

PREVENTIVE MAINTENANCE (PM) OF THE EJECTOR

The design of the ejector makes its disassembly for cleaning by you, the operator, impractical. So, to make sure your M16A1E1 ejects those empty cases well clear of you and your rifle, follow the below listed steps on a monthly or as required (weekly if firing blanks) basis.

Step #1 - Remove the bolt from the carrier and hold it in your hand as shown with the ejector down and extractor up.

#2 - Place a few drops of CLP or RBC around the ejector to form a puddle. (as shown on right, drops of RBC can be placed on ejector by using a section of bore rod as a dipper).

#3 - Take a fired or dummy case and place it under the lip of the extractor. With a rocking motion, press the case down against the ejector. Since the ejector is spring-loaded, some resistance will be felt. Press on the case until it stops against the bolt face. Ease off with your thumb slightly and press down again. Repeat several times. Replace the CLP or RBC frequently. Once the spring action of the ejector is smooth and strong, dry off any excess.

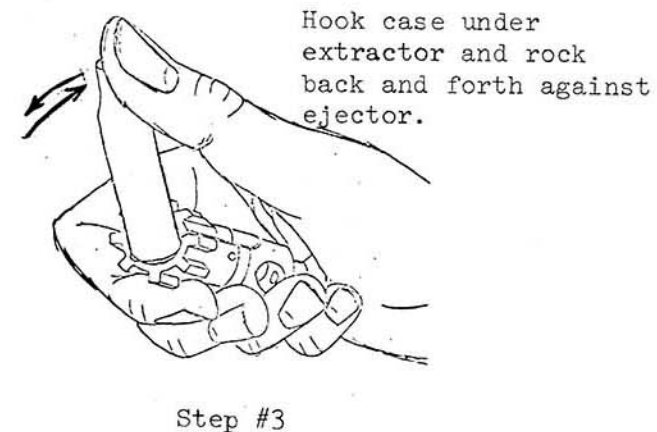
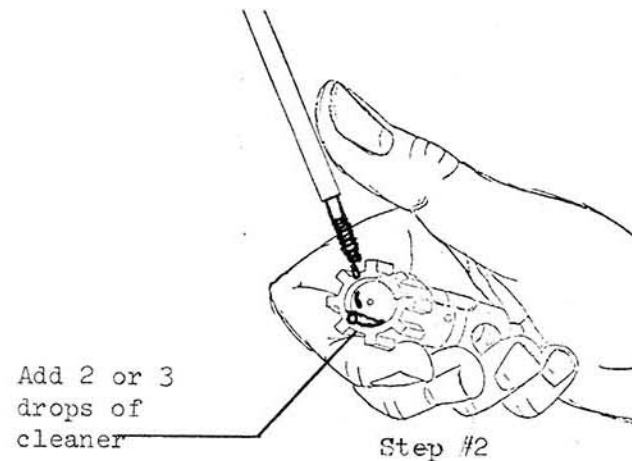
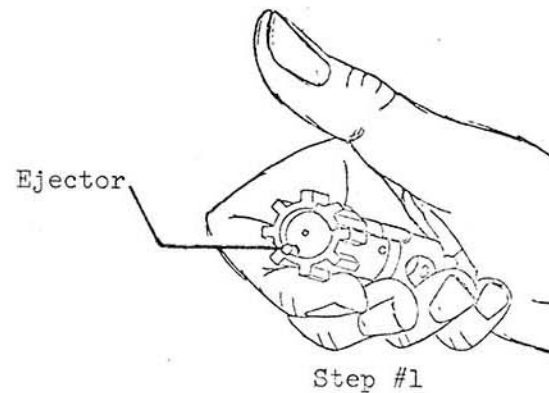

I hope you have heard a lot about the latest addition to your weapons cleaning system - Cleaner, Lubricant and Preservative - CLP for short. This single substance does all three things at once and does them all the time. It never goes on liberty.

- ONE. It contains solvents that dissolve firing residue and carbon.
- TWO. It lays down a layer of teflon, as it dries, to provide for lubrication.
- THREE. It prevents rust from forming.

The way you use this CLP is simple. Place a few drops on a patch or rag and go to work. Just clean your rifle with it until your patches and rags are coming out clean. Then take a fresh clean patch or rag and apply a fresh light coat. Your rifle is now clean. The problem with the above procedure is that as small unit leaders we have gotten into the habit of inspecting weapons, for turn-in to the armory let's say, "bone dry". That is not the way to go with CLP.

You should not make your troops "dry clean" their rifles. Mostly because when they do this, they use hot water or some kind of solvent that not only washes all the crud away, but also washes away all the teflon lubricant that has been building up on the rifle as a result of using CLP.

CLP will leave a film, or layer, of teflon that builds up over a period of time. This is one of the benefits of using CLP, especially in combat, where you might not have time to lube your rifle as often as you think it needs it. So, throw away your white gloves. But, carry a rag with you to wipe your hands when you inspect rifles, because your fingers are going to get a little slick if your troops have used the right amount of CLP on their rifles.

Now, if you are going to inspect rifles the following day, give your troops a few minutes to wipe their rifles down again. Remember, CLP is a cleaner and it never stops working. So, overnight while the teflon has been forming a film for lubrication, the cleaning solvents in the CLP have been at work in the nooks and crannies (actually in the pores of the metal) seeking out carbon and firing residue.

Armory and Ordnance Inspectors

You professionals who inspect weapons and armories should be the experts who are out there insisting that a light coat of CLP be kept on rifle metal parts at all times. And, since it's always at work cleaning, expect "a little" carbon to be present. If there is doubt as to whether the rifle is or was cleaned properly or not, field strip it. As the expert, you should be able to tell from plenty of other indicators (carbon under extractor, on firing pin or bolt, etc.) whether or not the rifle was cleaned, lubed, and preserved properly.

CLEAN...INSPECT...LUBE

With the rifle disassembled, thoroughly clean, inspect and lube, so you have a reliable weapon you can always depend on.

After firing, clean your weapon for 3 consecutive days with Rifle Bore Cleaner (RBC). Wipe dry and lube according to lubrication instructions. *

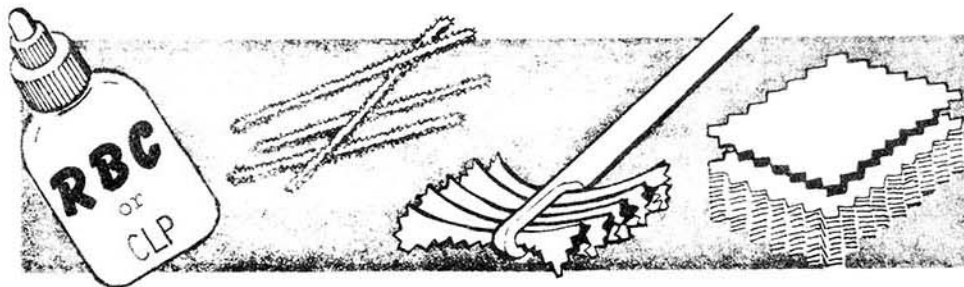

Cleaning materials: swabs, pipe cleaners and RBC are expendable items that are available from Company Supply.

If any parts are missing or defective see your ARMORER.

*CLP may be used instead of RBC.

THOROUGH CLEANING upper receiver



CLEAN WITH RBC
or CLP

- All Areas of Powder Fouling, Corrosion, Dirt & RUST
- Bore & Chamber
- Locking Lugs
- Gas Tube

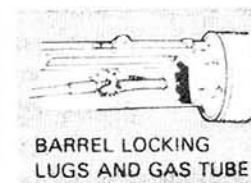
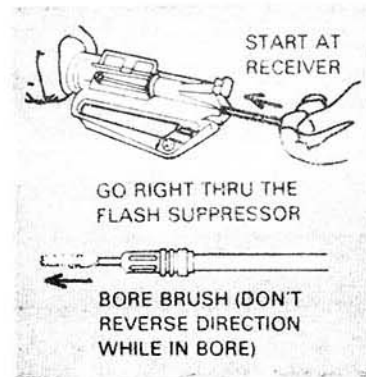

Use a worn bore brush to get outside surface of protruding gas tube (get sides and bottom from bottom of receiver)

THOROUGH CLEANING bolt carrier group

- Outer & Inner Surfaces of Bolt Carrier
- Carrier Key
- Firing Pin Recess and Firing Pin
- Firing Pin Hole (Use Pipe Cleaner There)
- Carbon Deposits & Dirt from Locking Lugs
- Areas Behind Bolt Ring and Under Lip of Extractor

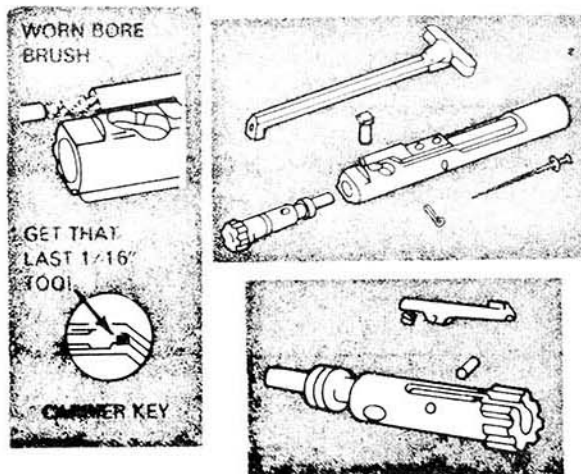

THOROUGH CLEANING lower receiver group

- All Areas of Powder Fouling, Corrosion and Dirt
- Wipe Dirt from Trigger Mechanism
- Clean Buffer and Inside Lower Receiver Extension

CAUTION
Do not use wire brush or any type of abrasive material to clean aluminum surfaces

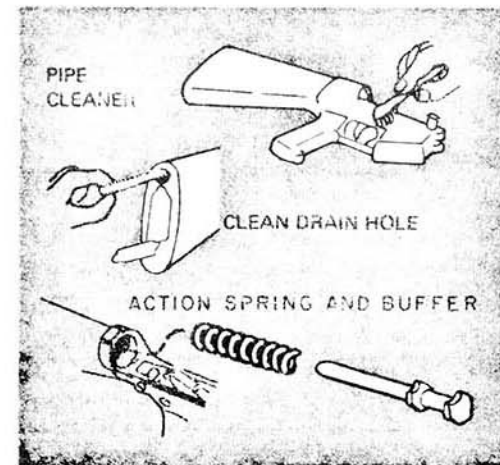

LUBE GUIDE

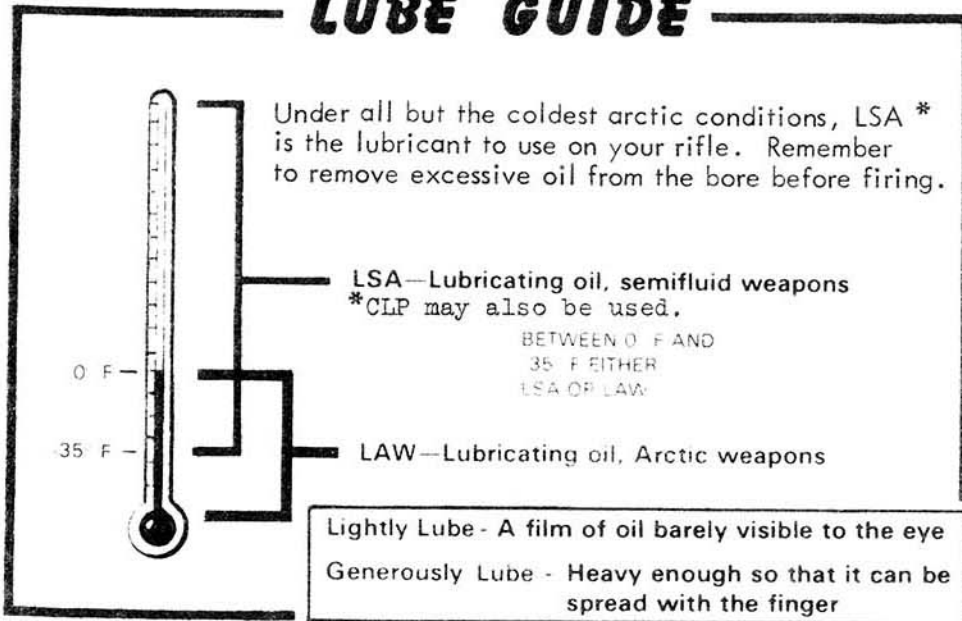

LUBRICATING upper receiver



LIGHTLY LUBE
BORE & CHAMBER, OUTER SURFACES OF BARREL AND FRONT SIGHT, SURFACES UNDER HANDGUARD, DEPRESS FRONT SIGHT DETENT SEVERAL TIMES TO WORK LUBE INTO THE SPRING

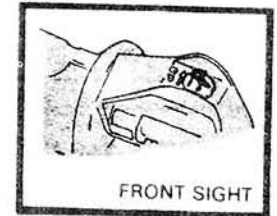
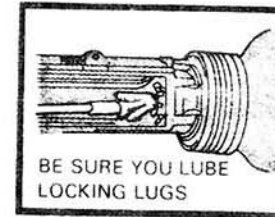

LUBRICATING bolt carrier group

CAUTION

lightly lube
firing pin and
firing pin recess
in bolt



GENEROUSLY LUBE OUTSIDE OF THESE PARTS

MAKE CERTAIN TO GET
CAM PIN AREA, PISTON
RINGS, AND OUTSIDE OF
THE BOLT BODY



DRY WITH PIPE CLEANER,
THEN PLACE ONE DROP LSA *

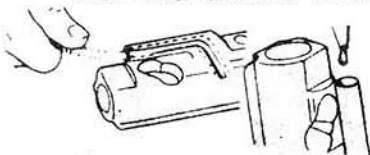

CARRIER KEY

LIGHTLY LUBE CHARGING HANDLE,
INNER AND OUTER SURFACES OF
BOLT CARRIER. GENEROUSLY
LUBE SLIDE AND CAM PIN AREA OF BOLT

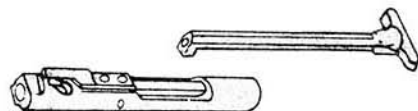

*CLP may also be used.

LUBRICATING lower receiver group

ACTION
SPRING

BUFFER

INSIDE
LOWER RECEIVER
EXTENSION

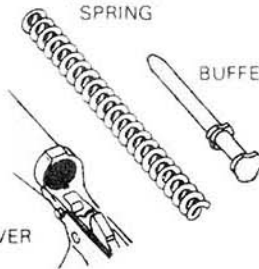

GENEROUSLY LUBE

TAKE DOWN AND PIVOT PINS



INSIDE PARTS LOWER RECEIVER

INSPECT-before assembly

WARNING DO NOT interchange bolts between rifles

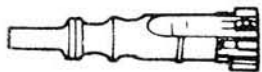

BOLT - Cracks or fractures, especially in the cam pin hole area. Bolts that contain pits extending into the firing pin hole need replacing.

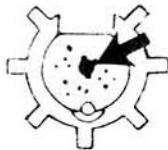

FIRING PIN RETAINING PIN - Bent, busted, badly worn



CAM PIN - Cracked, chipped or missing



FIRING PIN - Bent, cracked or blunted or pointed end

EXTRACTOR AND EXTRACTOR SPRING - Check extractor for chipped or broken edges in the area of the lip that engages the cartridge rim.

IF PARTS ARE MISSING OR DEFECTIVE, SEE YOUR ARMORER

ASSEMBLY

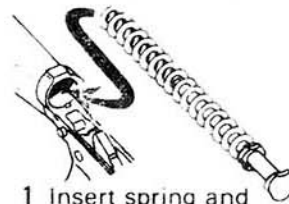

1 Insert spring and buffer

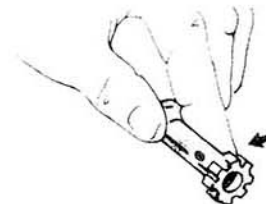

3 Push in extractor pin

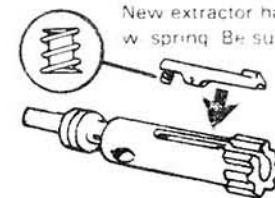

2 Insert extractor and spring



4 Slide bolt into carrier

New extractor has a silicone insert w/ spring. Be sure not to lose it.

If the spring comes loose, put the large end of spring in the extractor and seat.

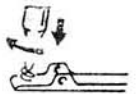

WARNING
Don't switch bolts between rifles.

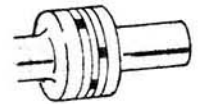

Don't switch bolts between rifles.

ASSEMBLY cont.

5 Replace bolt cam pin

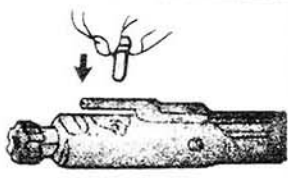

6 Drop in and seat

FIRING PIN

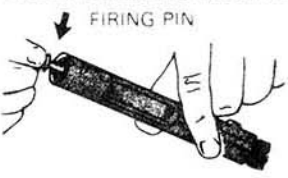

GIVE CAM PIN A 1/4 TURN AFTER ASSEMBLY

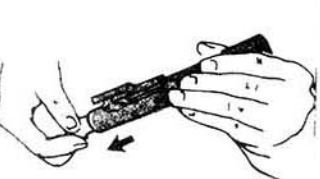

7 Pull bolt back

8 Replace retaining pin



NOTE
Firing pin should not fall out when bolt carrier group is turned upside down

9 Engage, then push charging handle part way

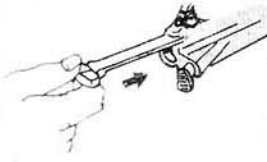

10 Slide in bolt carrier group

BE SURE BOLT IS STILL UNLOCKED



11 Push in charging handle and bolt carrier group together

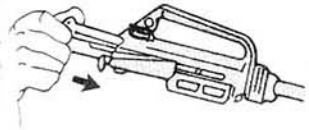

12 Join upper and lower receivers

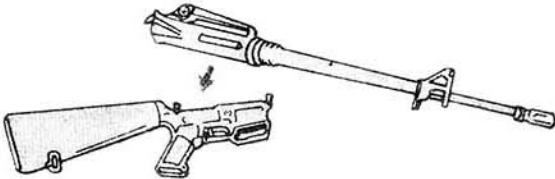

13 Engage receiver pivot pin

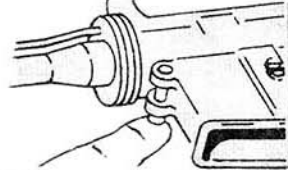

ASSEMBLY cont.

CAUTION:
Selector lever must be
on safe or semi before
closing upper receiver

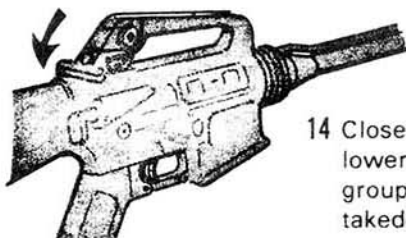
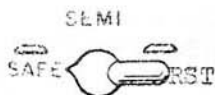

14 Close upper and
lower receiver
groups. Push in
takedown pin



HOLD SLIP
RING DOWN

15 PUT HANDGUARDS IN PLACE*

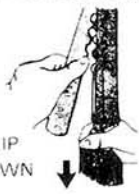

CHECK FOR FULL
ENGAGEMENT

RELEASE
SLIP RING

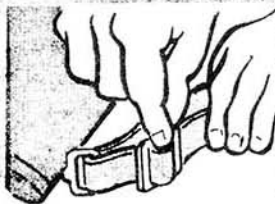

16 Snap on sling

*Round handguards are identical. One goes on the top while the other goes on the bottom.

DID YOU INSTALL EVERYTHING?

- *extractor & spring*
- *extractor pin*
- *bolt*
- *cam pin*
- *firing pin*
- *retaining pin*

EVERYTHING WILL
WORK SLICK IF YOU
HAVE ASSEMBLED
ALL THE PARTS
CORRECTLY

CHECK THE
selector lever
BY PERFORMING THE
**FUNCTIONAL
CHECK**

SEE PAGE 33

MAGAZINE DISASSEMBLY

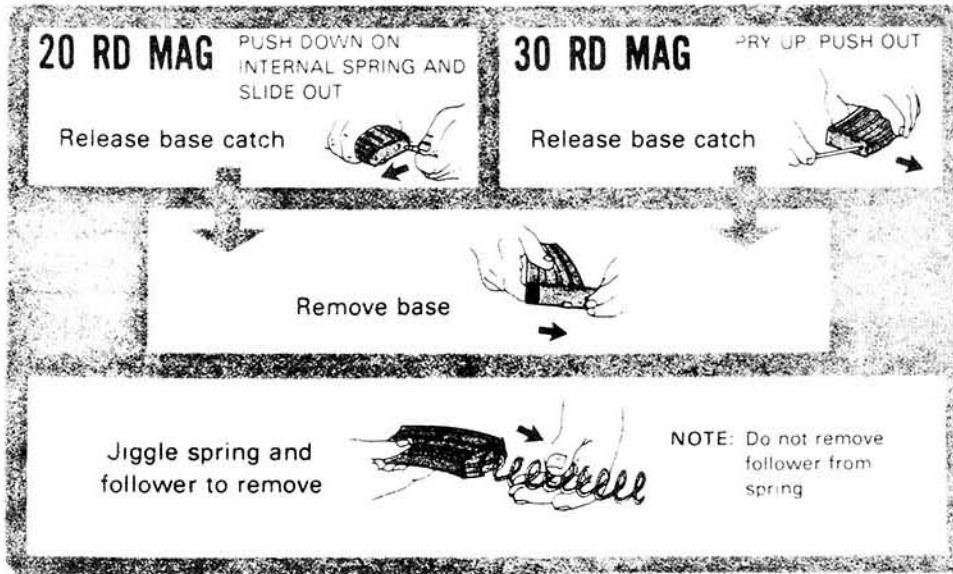

MAGAZINE ASSEMBLY

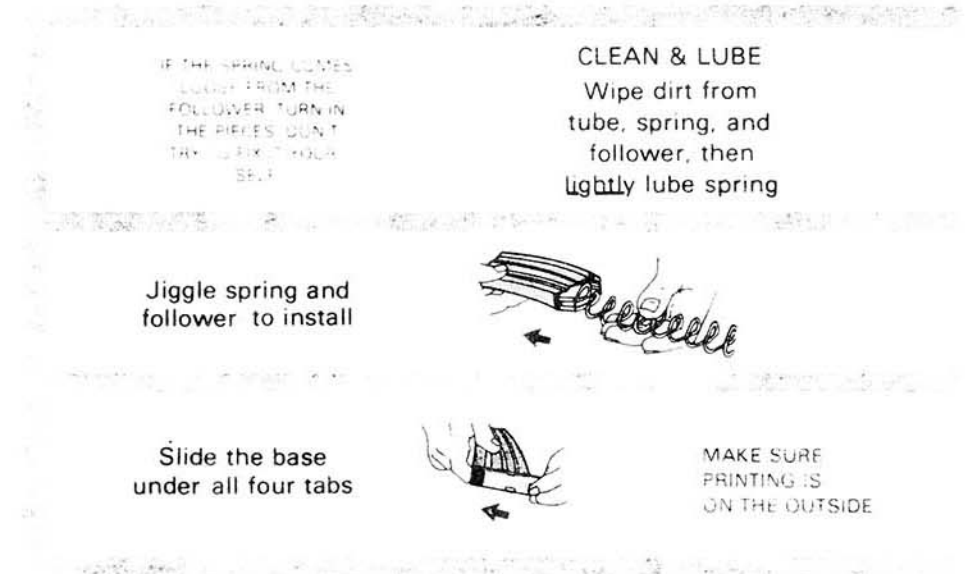

PMCS* before operation and. **FUNCTIONAL CHECK**

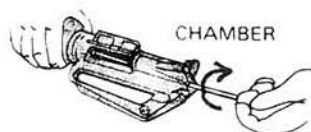

1 Remove excessive oil

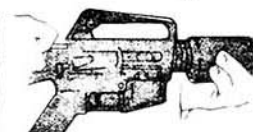

2 Retract bolt to assure free movement between bolt carrier and gas tube



4 Mag secure?

3 Perform functional check to assure selector lever works properly

next page
then
back
to
step 4

* Preventive Maintenance Checks and Services

(REMOVE MAG. CHECK CHAMBER)

SELECTOR LEVER ON:



Pull charging handle to rear and release. Place on safe. Pull trigger. Hammer should not fall.

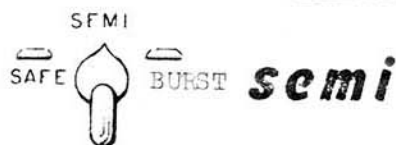

Place selector in semi. Pull trigger and hold to rear. Hammer should fall. Pull charging handle to rear and release. Release trigger and pull again. Hammer should fall.

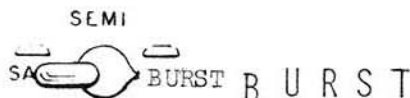

Place selector on burst. Pull charging handle to rear and release. Pull trigger and hold to rear. Hammer should fall. Pull charging handle to rear and release. Release trigger. Hammer should not fall. By pulling the trigger again, hammer should fall.

ADJUSTABLE REAR SIGHT HAS TWO APERTURES FOR RANGE

NORMAL RANGE (0-700 METERS)

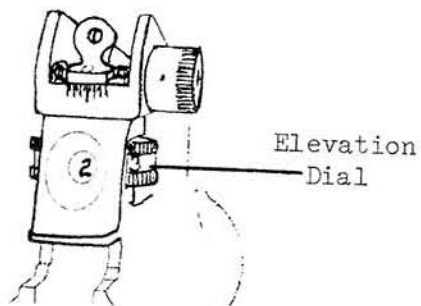

NORMAL RANGE - The unmarked aperture is used for 0-700 meters range. As shown above on the left, sight is set for 200 meters. By turning the elevation dial to 3, 4, 5, 6, or 7, that range (in hundreds of meters) is automatically set.

EXTENDED RANGE (800 METERS)

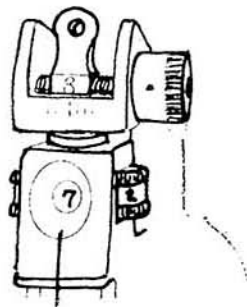

EXTENDED RANGE - The aperture marked with the "8" is used only for firing at 800 meters. As shown above, the "7" must be set on the elevation dial at the same time the extended range aperture is used. As shown above, the sight is now set for 800 meters

FRONT SIGHT

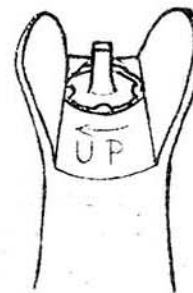

The square front sight post has 4 notches. They are only used to zero the rear sight. Once the rear sight is zeroed, all future elevation changes are made at the rear sight.

CARE, CLEANING AND PRESERVATION OF
THE ADJUSTABLE REAR SIGHT

The adjustable rear sight on your M16A1E1 requires a little extra care. To operate properly, it must be lubricated. CLP is great for this purpose. One or two drops on the moving parts is usually OK. But you must rotate these parts back and forth a few times to make sure the lubricant is spread evenly above and below the "dial" and on the "elevation screw shaft" as well (see illustration on right). This is also true of the windage knob.

The "elevation screw shaft" should also be lubed from inside the upper receiver. Turn the upper receiver upside down and, with the charging handle removed, you can see the bottom of the elevation screw shaft. Put 2 or 3 drops on it and, while keeping the upper receiver upside down, rotate the elevation dial back and forth a few times.

When you are finished lubing the rear sight, place your correct zero windage and your battlesight zero of 200 meters. You will notice the rear sight comes all the way down in the receiver when the "2" is in the window. On some rifles, the "2" may move a little past the window when the sight is all the way down. Always place the "2" exactly in the window. This is easy to do because a "click" will be felt when the "2" first shows in the window. This is how you should carry your rifle. Your NCO will tell you when to adjust for greater range. This will help keep dirt and water out of the sight mechanism and also protect the sight from damage.

When conducting amphibious operations if your rear sight gets wet with salt water, clean it immediately if possible. If you don't have time to clean and lube it properly right away, wash it off with fresh water from your canteen or some other source.

LUBRICATE AND KEEP EXTRA CLEAN

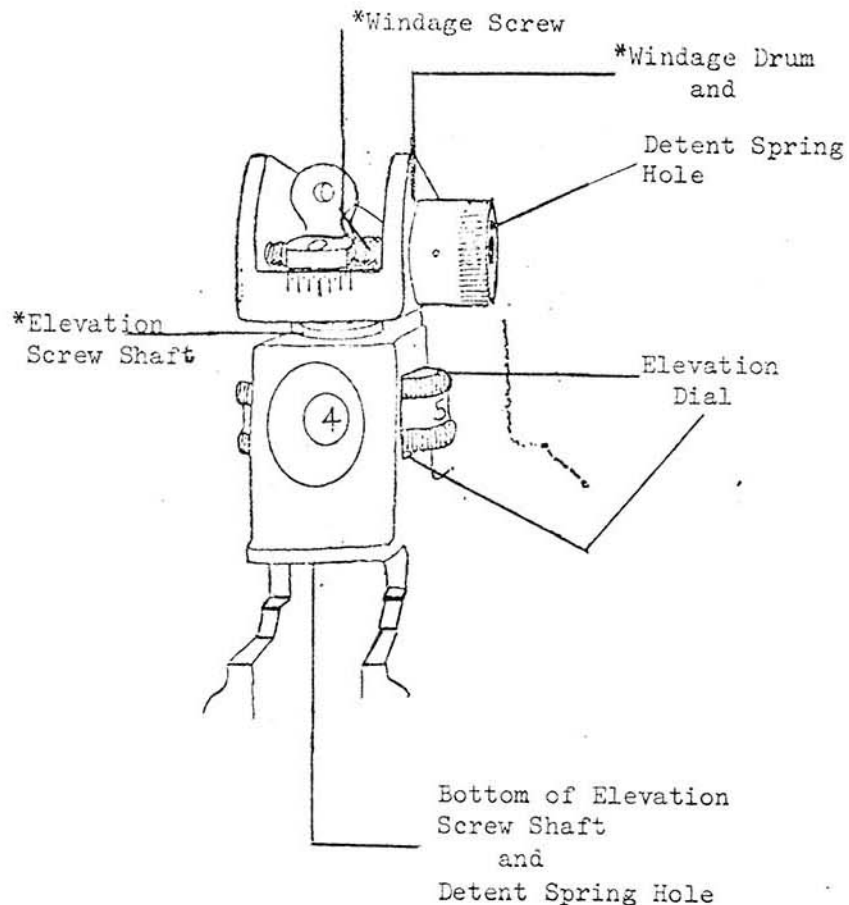

BATTLESIGHT ZERO

To Zero the rifle, you must have the front sight post (Elevation) and the rear sight windage knob adjusted so that you can hit your point of aim at 200 meters while the rear sight elevation dial is at the last full "click" before mechanical bottom and the "2" is visible in the window. (See illustration on right).

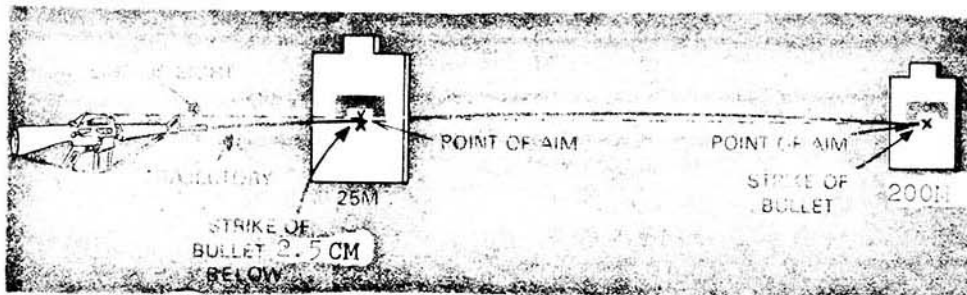

NOTE: In order to battlesight zero, you adjust your front sight post and windage knob so you can hit an aiming point at 200 meters. Zeroing can also be accomplished over a 25 meter range by adjusting the sights so that the bullet will strike 2.5 centimeters below the point of aim. Remember to make all elevation changes during zeroing on the front sight post and be sure your rear sight elevation dial reads "2" in the window.

BATTLESIGHT ZERO ADJUSTMENT



To adjust elevation, depress detent, rotate post. To raise strike of bullet, rotate post in the direction of arrow marked up. Reverse the direction of rotation to lower strike of bullet. Each graduation (notch) moves the point of impact of bullet as indicated in chart.

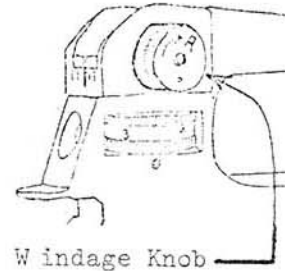

Windage Knob

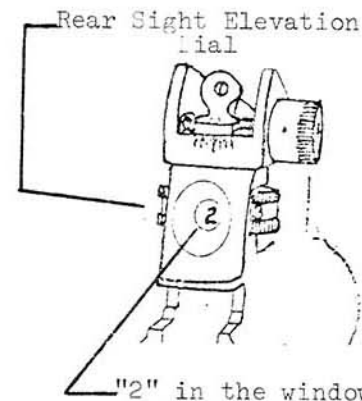

"2" in the window

For Front Sight Post Zero
(per click)

<u>IMPACT</u>	<u>DISTANCE</u>
0.9cm(3/8 in)	25 Meters
3.5cm(1 3/8 in)	100 Meters
7.0cm(2 3/4 in)	200 Meters

For Windage Knob (per click)*

0.3cm(1/8 in)	25 Meters
1.25cm(1/2 in)	100 Meters
2.50cm(1 in)	200 Meters
3.8cm(1 1/2 in)	300 Meters
5.0cm(2 in)	400 Meters
6.3cm(2 1/2 in)	500 Meters
7.6cm(3 in)	600 Meters
8.8cm(3 1/2 in)	700 Meters
10.0cm(4 in)	800 Meters

*All the above values are rounded to nearest 1/2 in.

FIELD FIRING TECHNIQUES

Your M16A1E1 has a fully adjustable rear sight. Once you establish your zero (see previous page) the elevation dial is "set" starting at 200 meters and continuing in 100 meter increments up to 800 meters. All you need to do is rotate the dial until the number (3, 4, 5, 6 or 7) you desire appears in the window. Then obtain a good sight picture and good sight alinement on the target and fire. You will notice during this that there are "clicks" between the numbers. These can be used as well if you need one or more clicks elevation past a certain number to hit your target.

You will also notice that the normal rear sight aperture will "flip" forward and expose a taller aperture marked with an "8". This taller aperture is only used when the "7" is in the window. Since you will very seldom shoot at this range, it is a good idea to keep the tall aperture layed back, thereby positioning the normal aperture and the wind-age reference mark (marked on the top of the tall aperture) in position for shooting at more likely ranges.

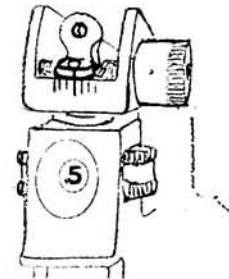

Setting for
500 Meters

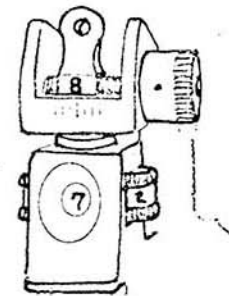

Setting for
800 Meters

OPERATION - loading and chambering a round



1 With hammer cocked, place selector lever on SAFE

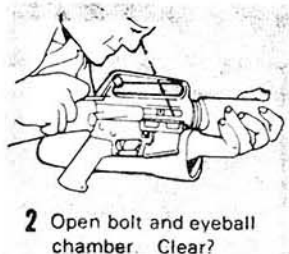

2 Open bolt and eyeball chamber. Clear?

BOLT ASSEMBLY OPEN

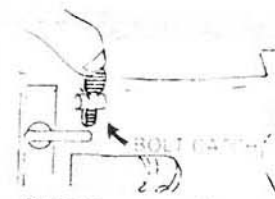

Depress upper portion of bolt catch



TAP forward assist to insure bolt is fully forward & locked

BOLT ASSEMBLY CLOSED



Pull charging handle fully rearward



Release the charging handle



Never "ride" the charging handle. Let it go on its own



TAP forward assist to insure bolt is fully forward & locked

MAGAZINE MAY BE LOADED WITH BOLT ASSEMBLY OPEN OR CLOSED



3 Push upward until magazine catch engages and holds magazine

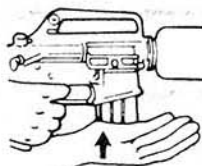



4 Tap upward to make sure it's seated right

Three Round Burst Control: To guarantee a 3-round burst the first time you pull the trigger, follow these steps: Start with a clear weapon - (1) Place selector on BURST. (2) Pull trigger and hold it to the rear. (3) Pull charging handle to the rear and let it go 3 times. (4) Pull charging handle to rear one more time; hold it to the rear; let go the trigger; and push in the bolt lock thereby locking the bolt to the rear. Slide the charging handle all the way forward. (5) Place selector on SAFE. (6) Insert a loaded magazine and push on the other end of the bolt latch to allow the bolt to fly forward. (7) Placing the selector on BURST at this point and pulling the trigger will give you a 3-round burst.

IMMEDIATE ACTION

If your rifle stops firing before you do . . . **S.P.O.R.T.S.** S.P.O.R.T.S. is an acronym* to help you remember the following actions -- **Slap, Pull, Observe, Release, Tap, Shoot.**

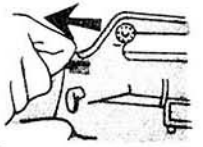
*ac-ro-nym: a word formed from the initial letters of each word in a group of words that convey a meaning or action.

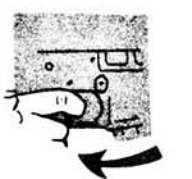
 <p>2 PULL charging handle all the way back. OBSERVE ejection of case or cartridge. Eyeball chamber and check for obstruction.</p>	 <p>3 If cartridge or case is ejected or chamber is clear, RELEASE charging handle to feed new round (Don't ride the charging handle)</p>	 <p>4 TAP forward assist</p>	 <p>5 Now SHOOT. If it won't fire, look for trouble and apply remedial action</p>
---	--	--	---





1 SLAP upward on magazine to make sure it's properly seated.

REMEDIAL ACTION

WARNING

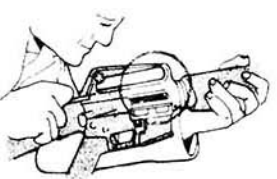
If your rifle stops firing with a live round in the chamber of a hot barrel, remove the round fast. However, during training, if you cannot remove it within 10 seconds, wait 15 minutes with the rifle pointing in a safe direction. This way you won't get hurt by a possible ammo cook-off, which could happen 10 seconds after contact with a hot chamber.

<p>If your rifle fails to fire after performing steps 1 thru 5, check again for jammed cartridge case</p>		 <p>If a cartridge case is in the chamber, tap out with a cleaning rod.</p>
---	--	--

IF YOUR RIFLE STILL FAILS TO FIRE, CHECK TROUBLESHOOTING

PROJECTILE LODGED IN BORE LIMITED PM CLEANING AS NEEDED

WARNING

If an audible "POP" or reduced RECOIL is experienced during firing, immediately CEASE FIRE, remove the magazine (1), lock the bolt to the rear (2), and place the selector lever on the "SAFE" position (3). Visually inspect and/or insert a cleaning rod into the bore to insure there is not a projectile lodged in the bore (4).

DO NOT APPLY IMMEDIATE ACTION.

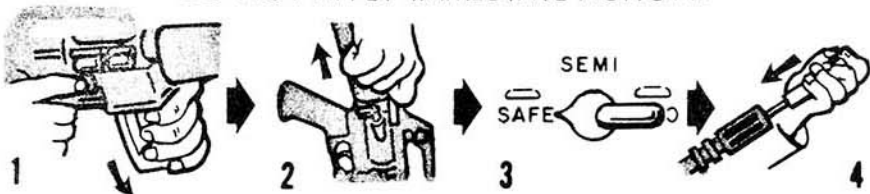

If a projectile is lodged in the barrel of the weapon, DO NOT attempt to remove it. Turn the weapon in to the armorer.

CLEAR YOUR RIFLE



1 Look for fouling in bore and chamber

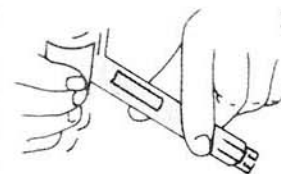

2 Remove bolt carrier group and clean carbon and oil from firing pin and all surfaces of bolt/bolt carrier with dry swabs. Clean

firing pin hole and bolt carrier key with pipe cleaner. Apply light coating of LSA paying special attention to slide and cam pin area

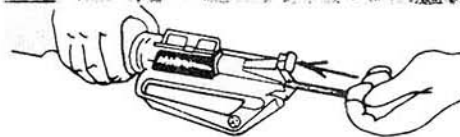

3 "Swab out" (from chamber to muzzle)

CAUTION: Don't use a dry cleaning rod. Oh yeah, make sure swab goes clear through flash suppressor



4 After cleaning, apply a light coat of LSA. Lightly lubricate lugs in barrel extension

*CLP may also be used

UNUSUAL CONDITIONS

EXTREME COLD

- Clean and lubricate rifle with LAW. Keep it moisture free.
- Operate controls thru their entire range at intervals, to keep them from freezing up.
- When your rifle is not being used and kept outside, protect it with a cover.

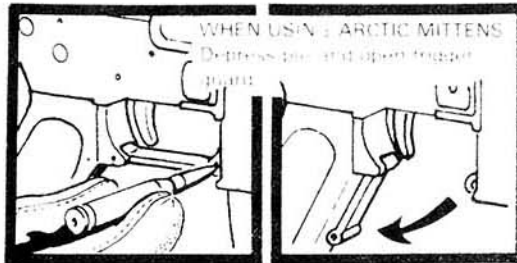

HOT CLIMATES

- Inspect rifle and bipod more frequently, especially the hidden surfaces of bolt carrier group, forward assist assembly and lower receiver components. Make certain they are lubricated using LSA *
- When handling, make certain to wipe dry, as moisture could cause corrosion. After drying, lubricate with LSA *

HOT, DRY CLIMATES

Clean and oil rifle more frequently with LSA *

DUSTY AND SANDY AREAS

- Clean and lubricate your rifle more frequently.
- Keep sand out of parts when inspecting, lubricating, or assembling rifle. Apply only a very light amount of lubrication on outside of rifle.
- Use magazine bag and muzzle cap for dust and sand protection.

CAUTION: Do not use magazine bag and muzzle cap on stored rifles.

* CLP may also be used.

AFTER FORDING

WARNING DO NOT FIRE RIFLE IF WATER IS PRESENT IN BARREL

HERE'S WHAT YOU DO!

AFTER YOU REMOVE THE CAP



POINT THE MUZZLE DOWN



PULL CHARGING HANDLE 2 TO 3 INCHES REARWARD AND ALLOW WATER TO DRAIN

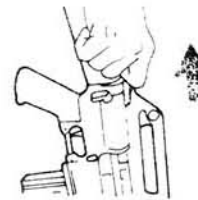



RELEASE CHARGING HANDLE AND STRIKE FORWARD ASSIST TO SEAT ROUND AND LOCK BOLT

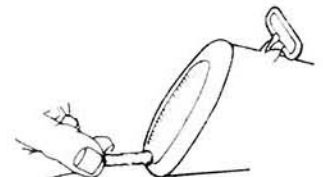

CLEAR THE DRAIN HOLE WITH A PIPE CLEANER AND DRAIN

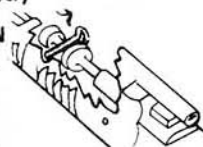

TROUBLESHOOTING

PROBLEM	CHECK FOR	WHAT TO DO
WON'T FIRE	Selector lever on SAFE	Put it on SEMI or BURST
	Improper assembly of firing pin	Assemble correctly RETAINING PIN GOES IN BACK OF LARGE SHOULDER OF FIRING PIN 
	Too much oil in firing pin recess	Wipe off 
	Defective ammo	Remove and discard
BOLT WON'T UNLOCK	Too much carbon on firing pin	Clean
	Dirty or burred bolt	See your NCO or your unit ARMORER

TROUBLESHOOTING

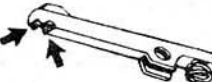
PROBLEM	CHECK FOR	WHAT TO DO
WON'T EXTRACT	Broken extractor spring	See your ARMORER 
	Dirty or corroded ammo	Remove. Push out stuck round with cleaning rod
	Carbon in chamber Fouling or carbon in extractor recess or lip	Clean chamber Clean
WON'T FEED	Dirty or corroded ammo	Clean 
	Dirty magazine	Clean
	Defective magazine	Replace
	Too many rounds in magazine	Take out excess
	Restricted buffer assembly action	Take out the buffer and spring, and clean

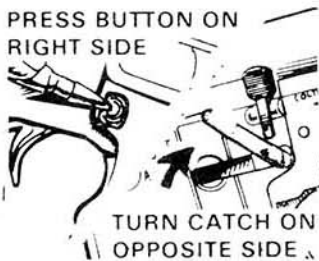

TROUBLESHOOTING

PROBLEM	CHECK FOR	WHAT TO DO
WON'T FEED	Magazine not fully seated	Adjust magazine catch PRESS BUTTON ON RIGHT SIDE  TURN CATCH ON OPPOSITE SIDE Turn catch clockwise to tighten and counterclockwise to loosen
	Defective magazine	Replace
DOUBLE FEED	Defective magazine	Replace

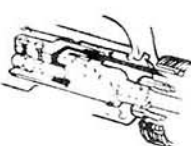
TROUBLESHOOTING

WON'T CHAMBER	Dirty or corroded ammo Damaged ammo Carbon in chamber	Clean Replace Clean	
WON'T LOCK	Dirt, corrosion, or carbon buildup in barrel locking lugs Frozen extractor Restricted buffer assembly Restricted movement of bolt carrier group	Clean lugs Remove and clean Remove and clean Remove, clean, and lube. (When putting bolt back in, make sure gas tube fits into carrier key and moves freely)	
			

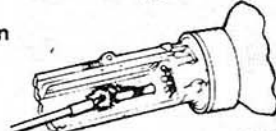
TROUBLESHOOTING

PROBLEM	CHECK FOR	WHAT TO DO
SHORT RECOIL	Gaps in bolt rings (not staggered)	Stagger ring gaps 
	Carbon or dirt in carrier key or on outside of gas tube	Clean 
	Q-Tip stuck inside carrier key	
BOLT FAILS TO LOCK AFTER LAST ROUND	Dirty or corroded bolt latch Faulty magazine	Clean Replace
SELECTOR LEVER BINDS	Needs oil	Lubricate with LSA

TROUBLESHOOTING

PROBLEM	CHECK FOR	WHAT TO DO
BOLT CARRIER "HUNG UP"	Round jammed between bolt and charging handle and/or doublefeed	1 Remove magazine 2 Hold charging handle back and bang rifle butt on ground. KEEP CLEAR OF MUZZLE*
		3 While bolt is held to rear, push charging handle forward. Round should fall through magazine well



CAUTION After round is removed, bolt is under tension



* If this fails, use a section of cleaning rod to push bolt fully to rear through ejection port.

SPEAKING OF TROUBLE

DON'T REMOVE THE COMPENSATING FLASH SUPPRESSOR! It has become pretty common for some of you to remove the old style flash suppressor from your old M16 for detailed cleaning purposes. This was never authorized and is still a "No No". (Even you armorers should refuse to remove it for cleaning purposes). The big problem here is that when you do it yourself (because the armorer won't) you don't use the right tool to take it off. You probably stick a bayonet or screwdriver in one of the slots and rotate it off. This can bend the ribs of not only the old style flash suppressor, but will seriously bend the ribs of the new compensating flash suppressor as well. The ribs bend because, at the factory, the suppressor is put on tight. In fact it is torqued on to about 20 pounds with a special wrench.

Something else is also done at the factory. The compensating flash suppressor is "set" to provide you with compensation or, in other words, to keep the muzzle down during automatic fire. This "setting" is a precise adjustment so don't disturb it. Even if you use the correct size open end wrench (19mm or 3/4 inch), you probably won't be able to index the slots in the correct location as shown below.

The Compensating Flash Suppressor has five slots. The 3rd or "middle" slot must be straight up.

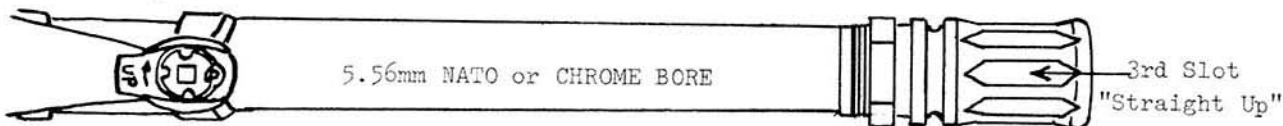

It should line up with the front sight post and the lettering on barrel and be on tight.

MORE TROUBLE

Don't remove the stock or the Pistol Grip. You are not authorized. Trouble is that when most of you remove these parts for detailed cleaning, you lose the small detents or damage the springs upon reassembly. You see, both the stock and pistol grip hold a spring in the rifle. These springs you can see when you take the stock or pistol grip off. But, you can't see the very small detents that the springs were pushing on because they are inside small holes in the receiver. And these detents don't just fall out either. The lubricant they need to work properly makes them "stick" inside their holes. Even if you bang the receiver on a table top, they usually won't fall out. But, when you dip the receiver in solvent or hot water, the lubricant dissolves and the detent falls out and goes down the drain. The only sure and easy way to get them out is with a piece of wire or a pipe cleaner. But, remember, you are not authorized to remove these parts. However, if there is a real need to remove them, because your rifle was submerged during a river crossing, let's say, then ask your armorer to do it. That is his job and he has the training to insure your rifle is reassembled properly.