

AD

REPORT R-1895

GAS TUBE FOULING CHARACTERISTICS OF
M193 BALL CARTRIDGES IN M16A1 RIFLE

by

LAWRENCE F. MOORE

74-2A

AUGUST 1968

Each transmittal of this document outside the Department of Defense must have prior approval of the Commanding Officer, Frankford Arsenal, Philadelphia, Pa., Attn: SMUFA J8000.



DEPARTMENT OF THE ARMY
FRANKFORD ARSENAL
Philadelphia, Pa. 19137

Digitized by:

DISPOSITION INSTRUCTIONS

Destroy this report when it is no longer required. Do not return it to the originator.

The findings in this report are not to be construed as an official Department of the Army position unless so designated by other authorized documents.

REPORT R-1895

GAS TUBE FOULING CHARACTERISTICS OF
M193 BALL CARTRIDGES IN M16A1 RIFLE

by

LAWRENCE F. MOORE

AMCMS Code 4810.16.0229.1

Each transmittal of this document outside the Department of Defense must have prior approval of the Commanding Officer, Frankford Arsenal, Philadelphia, Pa., Attn: SMUFA J8000.

Ammunition Development & Engineering Laboratories
FRANKFORD ARSENAL
Philadelphia, Pa. 19137

August 1968

ABSTRACT

The tests described in this report were conducted to determine the gas tube fouling characteristics of four lots of 5.56 mm M193 cartridges loaded with ball propellant when fired in the M16A1 rifle. Two ammunition lots were loaded with WC846 propellant (lots RA5244 and RA5320) and two with IMR propellant (lots TW18179 and TW18191). Each ammunition lot was fired in three rifles.

It was the aim to fire a 10,000-round function test in each rifle in which the rifles were cooled at 100-round intervals, lubricated at 500-round intervals, and cleaned at 2000-round intervals. The gas tubes were subjected to x-ray, air flow measurement, and weighing at 1000-round intervals.

Cartridge performance varied among lots with respect to

1. Fouling deposited in the gas tube and energy delivered to the bolt carrier. The fouling which developed in the gas tubes of three rifles in firing one cartridge lot loaded with WC846 propellant (lot RA5320) was sufficient to stop automatic function of the rifles.
2. Gas tube fouling with the other rifle/cartridge lot combinations was not sufficient to stop automatic function of the weapon.

TABLE OF CONTENTS

	<u>Page</u>
INTRODUCTION	1
DESCRIPTION OF MATERIEL	1
Ammunition	1
Rifles	2
Machine Rests	2
Lubricant	2
Air Flow Meter	2
TEST AND ANALYSIS	4
Inspection of Rifles	4
Test Procedure (Gas Tube Fouling Test)	4
Test Result Summary	6
Rifles 1 (843489), 2 (848305), 3 (850464); Pro- pellant Lot RA5244 (Figure 1)	6
Rifles 4 (855603), 5 (866133), 6 (856760); Pro- pellant Lot TW18179 (Figure 2)	15
Rifles 7 (859129), 8 (859908), 9 (861015); Pro- pellant Lot RA5320 (Figures 3 & 4)	15
Rifles 10 (862235), 11 (863323), 12 (863632); Pro- pellant Lot TW18191 (Figure 5)	17
X-ray Photographs	17
CONCLUSIONS	18
RECOMMENDATIONS	19

	<u>Page</u>
APPENDIX A - DESCRIPTION OF FLOW MEASUREMENT INSTRUMENT	20
APPENDIX B - AMMUNITION LOT INSPECTION REPORTS	24
APPENDIX C - PROPELLANT CERTIFICATION REPORTS	30
APPENDIX D - FLOW MEASUREMENT INSTRUMENT READINGS AND GAS TUBE WEIGHTS. . .	47
APPENDIX E - X-RAY PHOTOGRAPHS OF GAS TUBES . .	48
APPENDIX F - REPRESENTATIVE LABORATORY REPORT OF FOULING RESIDUE	67
APPENDIX G - FUNCTION AND CASUALTY DATA	69
APPENDIX H - ACCURACY AND VELOCITY TEST DATA .	143
DISTRIBUTION	198

List of Illustrations

<u>Figure</u>		<u>Page</u>
1.	Curves: Rifles 1, 2, 3, using Propellant Lot RA5244	8
2.	Curves: Rifles 4, 5, 6, using Propellant Lot TW18179	9
3.	Curves: Rifles 7, 8, 9, using Propellant Lot RA5320	10
4.	Malfunctions Recorded at 2000-round Intervals for rifles 7, 8, and 9, using Propellant Lot RA5320	11
5.	Curves: Rifles 10, 11, 12, using Propellant Lot TW18191	14
A1.	Schematic diagram and photograph of Half-Bridge Type Flow Measurement Instrument	21
A2.	Fixed Volume Flow Times vs "B" Pressure, with some Values of Discharge Coefficient . . .	22

List of Tables

<u>Table</u>		<u>Page</u>
I.	Data from Ammunition Lot Inspection Reports . .	3
II.	Cartridge Charge Weight and Air Space	4
III.	Summary of Function Data	7

INTRODUCTION

The object of this investigation was to determine the gas tube fouling characteristics of four lots of M193 cartridges loaded with ball propellant, when fired in the M16A1 rifle.

Fouling in the gas tube of the M16A1 rifle has been identified as a cause of malfunctions. The Rifle Project Manager has directed that tests be conducted with four cartridge lots (two assembled with IMR 8208M propellant and two with WC846 propellant) to obtain quantitative information on gas tube fouling. A preliminary test of a proposed system for measuring fouling in the gas tube by correlating the time required for a given volume of air to pass through a tube and the degree of gas tube blockage was conducted at Watervliet Arsenal.¹

A refined device, a half-bridge type flow measurement instrument, was made available for estimating the effective cross-sectional area of the tube in this test. A detailed description of this instrument is given in Appendix A.

DESCRIPTION OF MATERIEL

Ammunition

Four lots of M193 cartridges loaded with ball propellant were used in this test. Lots RA5244 and RA5320 were assembled with WC846 propellant and lots TW18179 and TW18191 were assembled with IMR 8208M propellant. A copy of each Ammunition Lot Inspection Report is shown in Appendix B. Propellant Certification Reports are shown in Appendix C.

¹Frankford Arsenal Report R-1883, Special Test of 5.56 mm Ammunition, dated Feb 1968.

²Not the same lots used in the feasibility test at Watervliet Arsenal.

Information from the Ammunition Lot Inspection Reports is given in Table I. Fired cartridges from each ammunition lot were disassembled for determination of charge weight and air space. This information is given in Table II.

Rifles

Thirteen new M16A1 rifles with the most recent design of parts (chromium-plated chambers and redesigned buffers) were used. The first 12 rifles were used in the main test. The gas tube on the 13th rifle (serial 863749) was replaced with a selected tube which had been found to have a large burr in the port extending into and covering approximately 30 percent of the gas tube. This latter rifle was fired in a separate short test.

Machine Rests

In the function test, the rifles were fired from a single Springfield Armory firing jack. A universal accuracy cradle was used in conjunction with a V-block and a Frankford Arsenal machine rest to support the rifle during the accuracy test.

Lubricant

The lubricant used in this test was "Lube Oil, Semi-Fluid, Automatic Weapons," MIL-L-46000A. It was applied liberally with a brush.

Air Flow Meter

An air flow measuring device, used to measure the relative degree of fouling inside the gas tube, is described in Appendix A.

TABLE I. Data from Ammunition Lot Inspection Reports

	<u>RA5244</u>	<u>RA5320</u>	<u>TW18179</u>	<u>TW18191</u>
Date of acceptance	22 Nov 66	9 Oct 67	26 May 67	14 Jun 67
Propellant type	Western Ball WC846	Western Ball WC846	IMR 8202 M	IMR 8208M
Propellant lot	873	1020	44938, 44939	44635
Propellant charge (gr)	28.1	28.0	25.5, 25.7 25.8, 25.9	25.7
Primer Type	RA92M	RA92M	Fed 195	Fed 195
Primer mix	5067	5067	K75	K75
Primer lots	RA 2-864, 865, 866, 867, 869 870, 871, 872	RA 2-1196, 1210, 1211, 1231, 1243 1244, 1245	200 A-B 200 A-B 202A	212 A-B 211 A-B
Corrected mean velocity at 15 fps	3240	3255	3218	3215
Standard Deviation (fps)	22	17	26.2	18.6
Max avg chamber pressure (psi)	45,700	47,500	50,400	49,600
Max avg port pressure (psi)	15,535	14,890	14,060	13,190
Accuracy (R - inches at 200 yds)	1.39	1.48	1.23	1.11

TABLE II. Cartridge Charge Weight and Air Space

Cartridge lot	<u>RA5244</u>	<u>RA5320</u>	<u>TW18179</u>	<u>TW18191</u>
Propellant charge (gr)	28.0	28.0	25.7	25.7
Air space (in.)	0.05	0.06	0.03	0.03

TEST AND ANALYSIS

Inspection of Rifles

The rifles were inspected at the start of the test and at 2000-round intervals during the test. At 1000-round intervals the gas tubes were tested for air flow measurement in the complete rifle assembly and then removed from the rifles and subjected to weighing and x-raying.

Flow measurement readings and gas tube weights are found in Appendix D; x-ray photographs are shown in Appendix E. A representative laboratory analysis of the residue from four gas tubes is given in Appendix F.

Test Procedure (Gas Tube Fouling Test)

The 12 rifles with original parts were each subjected to a 10,000-round test. Each rifle was designated to fire a particular lot during the test as follows.

<u>Rifle</u>		<u>Cartridge Lot</u>
<u>Code</u>	<u>Serial No.</u>	
1	843489	RA5244
2	848305	
3	850464	

<u>Rifle</u>		<u>Cartridge Lot</u>
<u>Code</u>	<u>Serial No.</u>	
4	855603	TW18179
5	856133	
6	856760	
7	859129	RA5320
8	859908	
9	861015	
10	852235	TW18191
11	863323	
12	863632	

Four rifles, one with each cartridge lot, were subjected to the test at one time. Five magazines were designated for each rifle. They were identified by letter and fired in sequence. The rifles were fired in 100-round cycles with a cooling period after each 100 rounds. The firing schedule during each 100-round cycle follows.

60 rounds, semiautomatically
 20 rounds, automatically in short bursts
 20 rounds, automatically in a single burst.

The cyclic rate was determined for the 20-round bursts. The rifles were disassembled and cleaned at 2000-round intervals during the test. The operating parts were removed from the rifle and lubricated at 500-round intervals. The bolt was disassembled from the carrier for this operation. The bore and gas tube were not cleaned during the test.

The 13th rifle (serial number 863749) was assembled with a selected gas tube which had a burr inside the tube at the port. The rifle was inspected and then one round of lot RA5244 was fired. The rifle was then disassembled and reinspected. The burr was missing or lost from the gas tube during firing.

A detailed summary of function and casualty data is included as Appendix G.

A considerable quantity of accuracy and velocity data was recorded. These data are not discussed in the text, but are included as Appendix H.

Test Result Summary

The tests described in the preceding section are summarized in Table III and Figures 1 through 5.

Rifles 1 (843489), 2 (848305), 3 (850464); Propellant Lot RA5244 (Figure 1)

Flow Meter Readings - Flow meter readings were essentially constant for each of the three rifles during the entire 10,000-round test. There was no appreciable change from the before-firing reading among any of the tubes.

Change in Gas Tube Weight - The gas tubes in rifles 1 and 2 generally increased in weight. Rifle 1 increased a maximum of 0.35 gram after firing 10,000 rounds; gas tube in rifle 2 increased a maximum of almost 0.50 gram under the same conditions.

The gas tube in rifle 3 behaved strangely in that it immediately gained slightly more than 0.45 gram within the first 1000 rounds fired, whereupon it tended to lose weight during the remainder of the test to 10,000 rounds. It is probable that the contamination received by the tube during the first 1000 rounds of test firing was steadily blown out in the course of the test.

Cyclic Rate - In all three rifles, cyclic rate increased somewhat during the test. Apparently there was not sufficient fouling in the gas tubes of these weapons to adversely affect cyclic rate.

Malfunctions - Malfunctions reached their highest frequency during firing of the final 2000-round cycle. Rifle 2 developed eight double rounds fired on single trigger pulls, while rifle 3 developed eleven failures-to-eject. Various malfunctions were obtained in rifle 1. (See Table III.)

TABLE III. Summary of Function Data

Legend:

BOB = Bolt over-rode base of round in feeding from magazine
 FF = Failure to feed round from magazine
 FJ = Failure to eject
 FS = Failure to strip round from magazine
 FX = Failure to extract

FBR = Failure of bolt to remain at rear after firing last round
 FFR = Failure to fire
 F2R = Fired 2 round with one rearward movement of the trigger and
 with the change lever set for semiautomatic fire
 SAT = Satisfactory

2000-rd Firing Cycle	Malfunctions	Cyclic Rate (rd/min)	Flow Meter Reading	Dispersion (Mean Radius) (in.)	Velocity (fps)	Remarks
<u>Rifle 843489 (1) and Cartridge Lot RA 5244</u>						
0	-	-	1.41	1.33	3170	
1	None	823	1.48	1.03	3159	
2	3-BOB	848	1.45	1.15	3188	Stoppages with magazine; the magazine was replaced.
3	1-FBR 1-BOB	864	1.50	1.50	3168	
4	2-BOB	874	1.47	1.46	3193	The extractor spring was broken and the ejector spring was damaged. Both springs were replaced. One burst with a rate of 552 rds/min caused by a missing gas tube retaining pin was not included in the average.
5	2-BOB 3-FJ 4-FFR 1-FBR 17	881	1.49	1.75	3162	
<u>Rifle 848305 (2) and Cartridge Lot RA 5244</u>						
0	-	-	1.50	1.05	3158	
1	• 1-FS	880	1.53	1.10	3208	The stoppage was on the first round in magazine 2D.
2	None	880	1.54	1.33	3177	
3	None	901	1.62	1.73	3179	
4	None	903	1.60	1.56	3161	
5	• 8-F2R 20/74	902	1.61	1.60	3165	
<u>Rifle 850464 (3) and Cartridge Lot RA 5244</u>						
0	-	-	1.60	1.24	3191	
1	1-FJ	943	1.47	1.42	3179	
2	1-FJ	915	1.49	1.67	3146	
3	None	957	1.46	1.59	3189	
4	None	981	1.45	1.68	3167	
5	11-FJ 13/13	970	1.50	1.61	3159	Ten stoppages were caused by a broken extractor spring.
<u>Rifle 855603 (4) and Cartridge Lot TW 18179</u>						
0	-	-	1.50	0.87	3106	
1	1-FJ	802	1.47	0.96	3053	
2	None	826	1.46	1.12	3098	
3	None	814	1.49	1.07	3112	The extractor spring was broken; it was replaced.
4	None	822	1.50	1.17	3101	
5	3-FJ 4/10	823	1.52	1.35	3057	The stoppages were caused by a broken extractor spring. The spring was replaced.
<u>Rifle 856133 (5) and Cartridge Lot TW 18179</u>						
0	-	-	1.48	0.90	3134	
1	None	799	1.43	1.12	3152	
2	None	798	1.40	1.24	3135	
3	2-FJ	831	1.43	1.55	3132	The stoppages were caused by a broken extractor spring. The spring was replaced.
4	7-FJ	821	1.36	1.48	3101	The stoppages were caused by a broken extractor spring. The spring was replaced.
5	1-FBR	821	1.42	1.28	3064	
<u>Rifle 856760 (6) and Cartridge Lot TW 18179</u>						
0	-	-	1.43	1.12	3153	
1	2-FBR	854	1.46	1.08	3130	
2	None	851	1.45	1.01	3114	
3	1-FBR	856	1.47	0.89	3122	
4	None	849	1.47	1.21	3085	
5	None	845	1.50	1.15	3070	

TABLE III. (Cont'd)

2000-rd Firing Cycle	Malfunctions	Cyclic Rate (rd/min)	Flow Meter Reading	Dispersion (Mean Radius) (in.)	Velocity (fps)	Remarks
<u>Rifle 859129 (7) and Cartridge Lot RA 5320</u>						
0	-	-	1.40	1.02	3192	
1	None	821	1.50	1.32	3160	
2	1-FBR 2-FJ	793	1.79	1.74	3196	The first three malfunctions were caused by a missing gas tube retaining pin.
3	1-FFR 1-FFR 11-FBR 69-BOB 67-FF 1-FJ	681 ^a 900 ^b	1.41	1.18	3200	The FFR was caused by improper assembly of the rifle. The gas tube was replaced after firing 1000 rounds on this cycle. All except 2 malfunctions occurred with the original tube. The flow meter reading was 2.35 with the old tube and 1.39 with the new tube.
4	1-BOB	855	1.73	1.62	3197	
5	21-BOB 1-FFR 5-FF 8-FJ 3-FBR	738 ^c 935 ^d	1.33	1.38	3188	The gas tube was changed after firing 1500 rounds on this cycle. Eight FJ occurred in firing the last 500 rounds. The flow meter reading was 2.23 with the old tube and 1.33 with the new tube.
<u>Rifle 859908 (8) and Cartridge Lot RA 5320</u>						
0	-	-	1.45	1.17	3205	
1	3-BOB	876	1.55	1.37	3217	
2	None	827	1.77	1.38	3197	
3	1-BOB	814	2.23	1.44	3207	
4	127-FF 13-FBR 33-BOB • 1-FS 52-FJ	646 ^e 989 ^f	1.56 ^f	1.58	3192	Seven FY occurred in firing 1500 rounds after replacing the gas tube.
5	2-FJ 1-FBR	941	1.88	1.31	3204	A broken extractor spring was replaced.
<u>Rifle 861015 (9) and Cartridge Lot RA 5320</u>						
0	-	-	1.40	1.50	3215	
1	None	834	1.69	1.27	3220	
2	None	736	2.01	1.52	3208	
3	50-BOB 59-FF 10-FBR	687 ^h 876 ⁱ	1.36	1.32	3226	The gas tube was replaced after firing 1000 round on this cycle. All malfunctions occurred with the original tube. The flow meter reading was 2.35 with the old tube and 1.34 with the new tube.
4	• 3-FS	840	1.52	1.54	3204	The stoppage occurred with magazine 9E. This magazine was replaced.
5 ^j	None	880	1.50			

^aFor 8 bursts with the original tube.^bFor 10 bursts with the new tube.^cFor 15 bursts with the old tube.^dFor 5 bursts with the new tube.^eFor 3 bursts with the original tube.^fThe flow meter reading was 2.77 with the old tube when removed and 1.41 with the new tube.^gFor 15 bursts with the new tube.^hFor 9 bursts with the original tube.ⁱFor 10 bursts with the new tube.^jThe test was discontinued after firing 9200 rounds on the function test because of exhaustion of the ammunition supply.

TABLE III. (Cont'd)

2000-rd Firing Cycle	Malfunctions	Cyclic Rate (rd/min)	Flow Meter Reading	Dispersion (Mean Radius) (in.)	Velocity (fps)	Remarks
<u>Rifle 862235 (10) and Cartridge Lot TW 18191</u>						
0	-	-	1.45	1.00	3139	
1	1-FBR	701	1.67	0.89	3097	
2	None	749	1.63	1.01	3100	
3	None	747	1.58	1.03	3099	
4	None	765	1.62	1.45	3089	
5	None	763	1.62	1.65	3065	
<u>Rifle 863323 (11) and Cartridge Lot TW 18191</u>						
0	-	-	1.45	1.18	3112	
1	None	703	1.60	1.52	3138	
2	12-BOB	697	1.67	1.31	3114	
3	1-FBR	727	1.69	1.41	3108	The disconnecter was replaced.
	1-BOB					
	14-F2R ✓					
4	4-BOB	735	1.64	1.51	3078	
	2-FBR					
5	1-FBR	770	1.66	1.84	3071	
<u>Rifle 863632 (12) and Cartridge Lot TW 18191</u>						
0	-	-	1.45	1.29	3154	
1	1-FS ✓	710	1.75	1.46	3134	
	3-FF					
	2-FBR					
	3-BOB					
	1-FFR					
2	None	730	1.60	1.23	3115	
3	None	761	1.60	1.52	3117	
4	1-FBR	767	1.60	1.44	3079	
5	None	770	1.63	1.39	3044	
<u>Rifle 863749 (13) and Cartridge Lot RA 5244</u>						
(The original gas tube was replaced with one which had a burr at the port.)						
0	-	-	1.51	-	-	
a	None	-	1.37	-	-	

aThe burr disappeared on firing 1 round.

Handwritten notes and calculations:

650
593
91.40 ← 800

622
45 (35 = 3)
574
93.40 ← 850

622
31
701
95.90 ← 100

622
70
98.80 ← 100

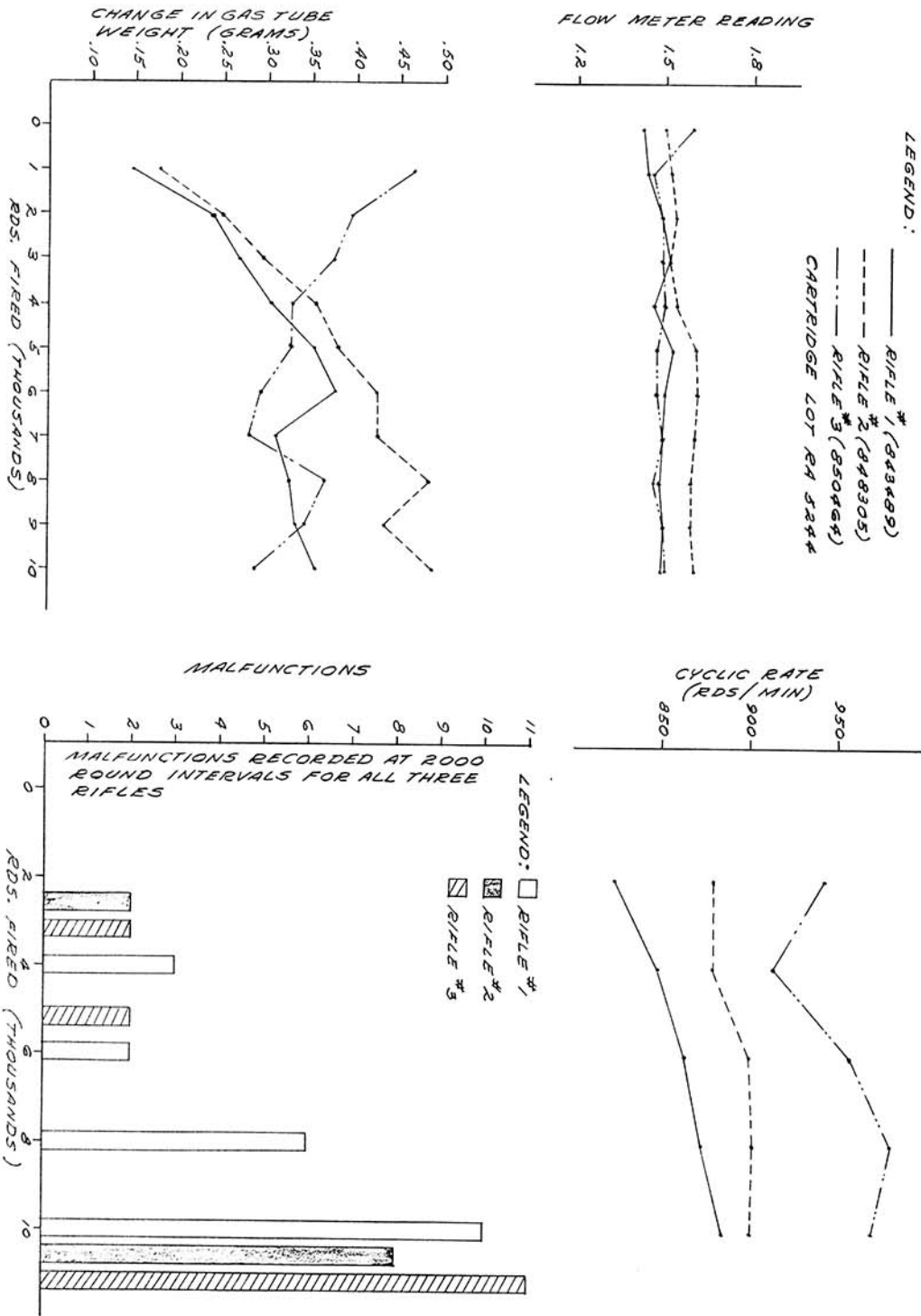

Figure 1. Curves: Rifles 1, 2, and 3, using Propellant Lot RA5244

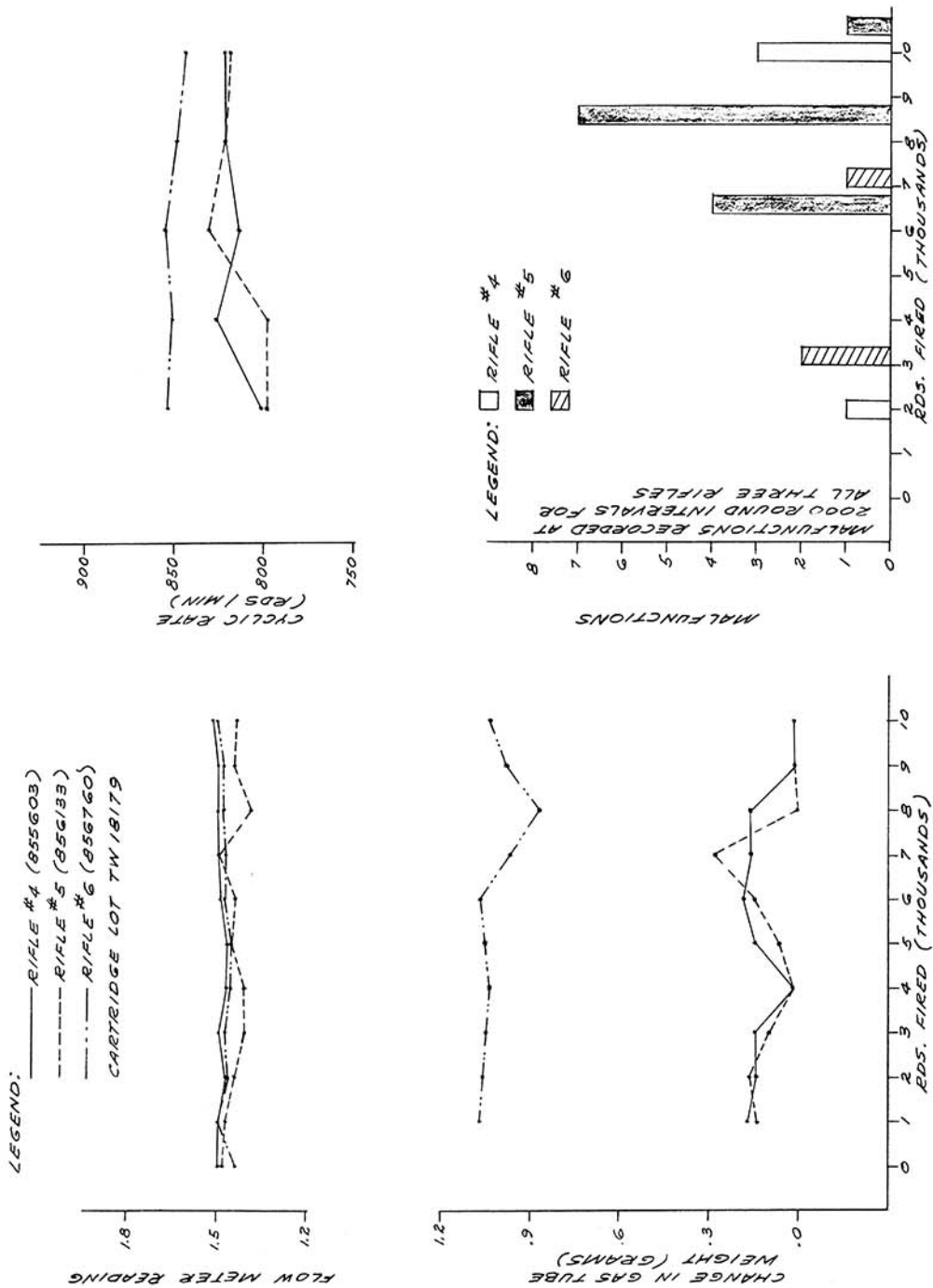

Figure 2. Curves: Rifles, 4, 5, and 6, using Propellant Lot TW18179

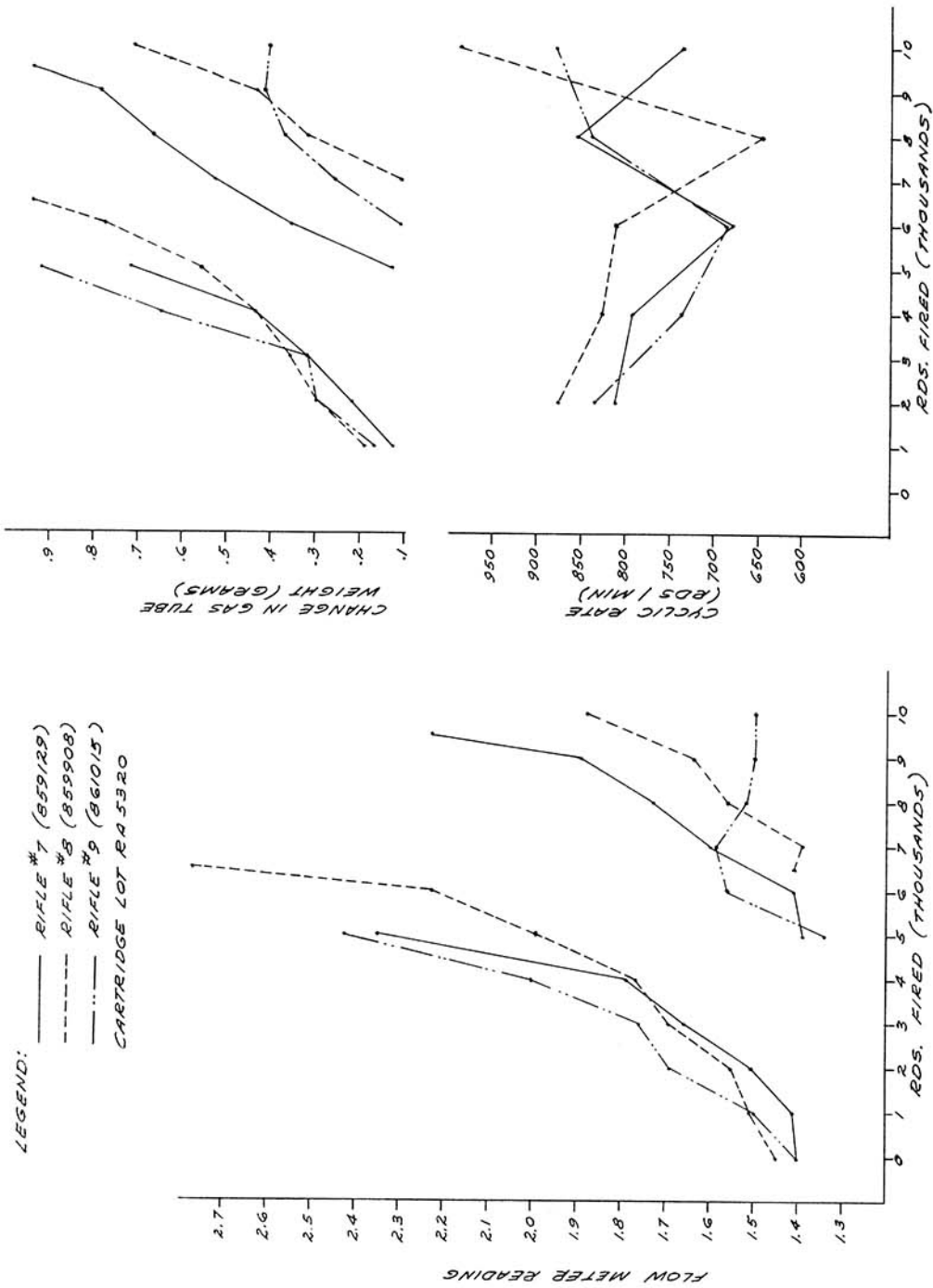

Figure 3. Curves: Rifles 7, 8, and 9, using Propellant Lot RA5230

LEGEND: □ RIFLE #7
 ■ RIFLE #8
 ▨ RIFLE #9
 CARTRIDGE LOT RA 5320

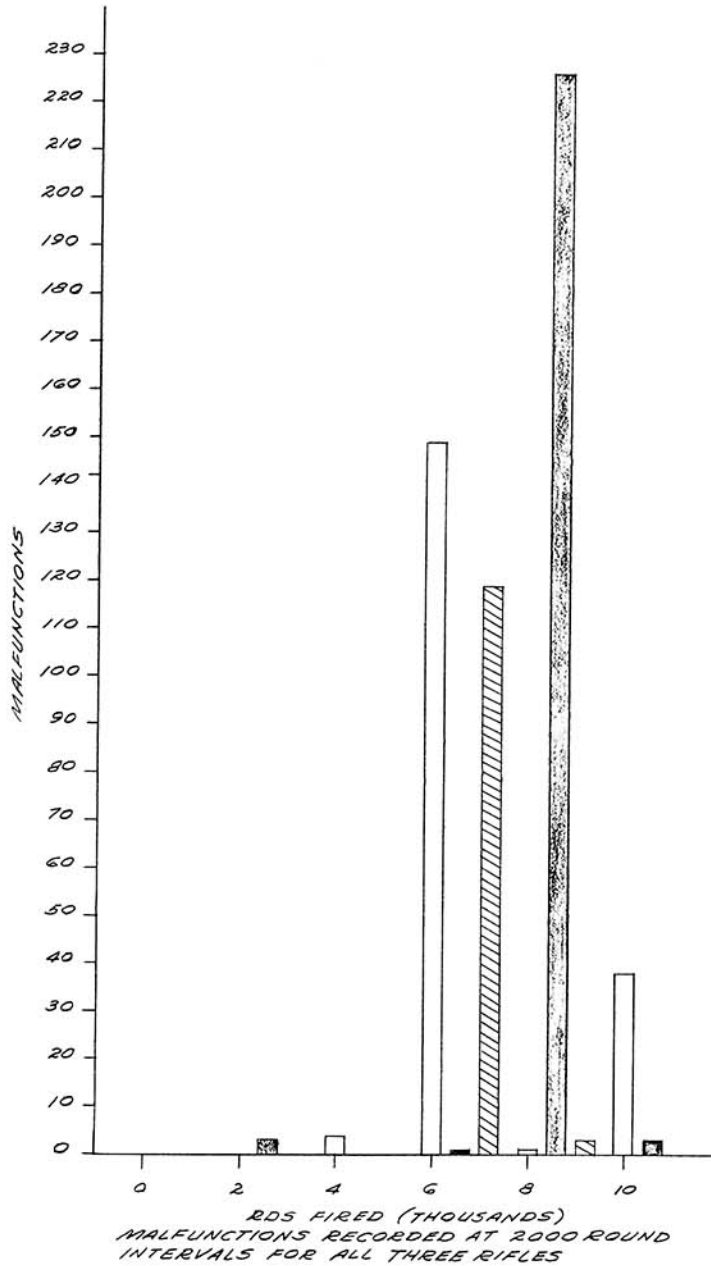

Figure 4. Malfunctions recorded at 2000-round Intervals for Rifles 7, 8, and 9, using Propellant Lot RA 5320.

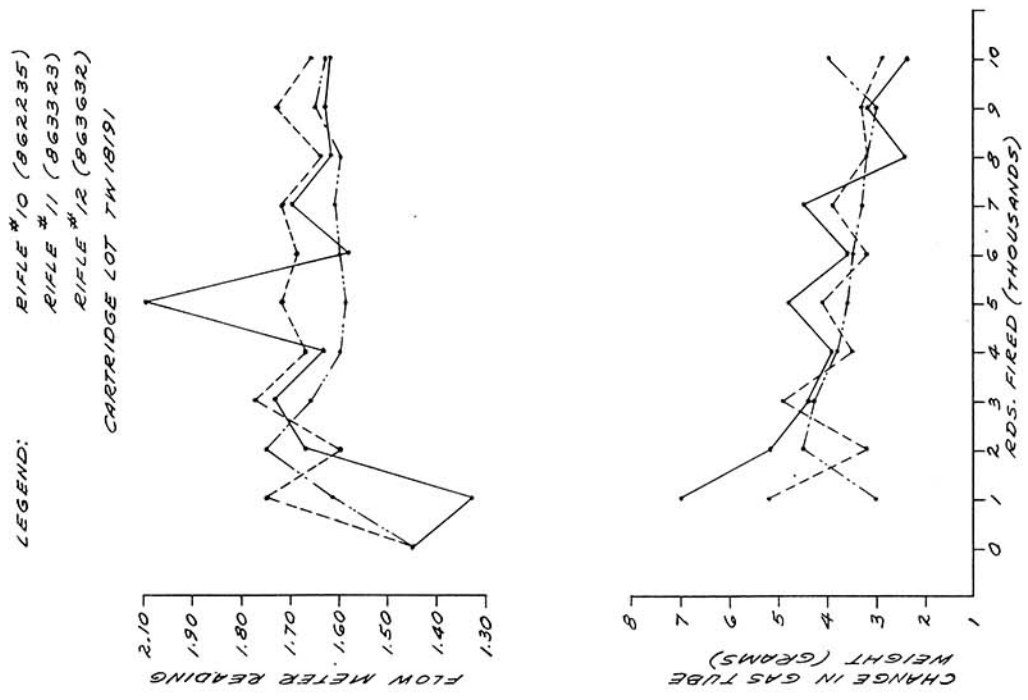
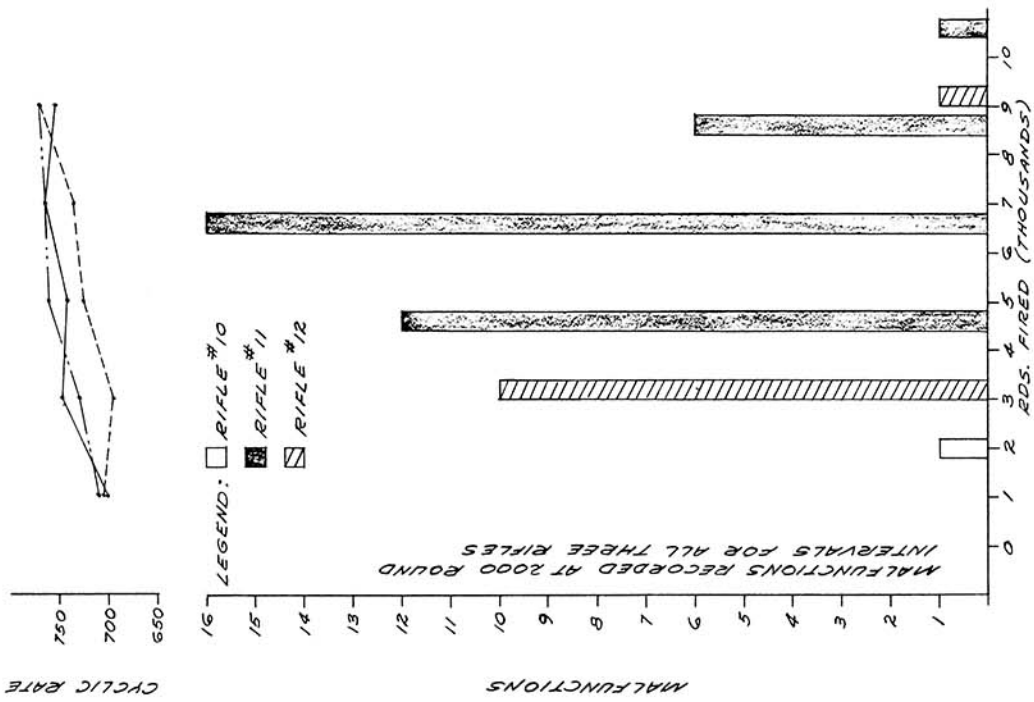

Figure 5. Curves: Rfles 10, 11, and 12, using Propellant Lot T#18191

Rifles 4 (855603), 5 (856133), 6 (856760); Propellant Lot TW18179
(Figure 2)

Flow Meter Readings - There was no significant change in flow meter readings during the 10,000-round test. The values obtained throughout the test were essentially equal to those obtained in the new (before-firing) condition.

Change in Gas Tube Weight - The gas tube in rifles 4 and 5 did not acquire significant quantities of fouling, as evidenced by the small weight gains. However, the gas tube in rifle 6 gained a noticeable quantity of fouling during the first 1000 rounds fired and generally maintained this weight during the remainder of the test. This startling change in weight was not shown in the corresponding flow meter measurement. It is possible that the fouling acquired in the gas tube of rifle 6 rapidly built up at first in the end of the tube, behind the plug, with no further significant increase in fouling during the remainder of the test. Assuming this to be the case, the effective cross-sectional area of the gas tube would not decrease. Hence, the normal flow meter readings.

Cyclic Rate - There was no significant change in cyclic rate in the course of firing the test. All of the rifles fired in the range of 800 to 850 rd/min.

Malfunctions - With all of the rifles, there was no particular pattern to the malfunctions encountered during the test. The trouble that was encountered consisted of weapon stoppages that were due mainly to broken extractor springs.

Rifles 7 (859129), 8 (859908), 9 (861015); Propellant Lot RA5320
(Figures 3 & 4)

Flow Meter Readings - Significant gas tube fouling occurred in this test such that all three rifles experienced stoppages. Rifle 7 stopped during the 5000-round level of test. The gas tube was replaced and the weapon stopped again at the 9500-round mark due to gas tube stoppage.

Rifle 8 stopped at 6500 rounds due to gas tube fouling, and rifle 9 stopped at 5000 rounds for the same reason.

In general, flow meter readings increased from a "before fire" reading of about 1.45 to a reading of about 2.3 at the point

of weapon stoppage. It seems that readings above 2 on the flow meter (with input pressure of 4 psi) indicate that the effective cross-sectional area of the gas tube had been sufficiently reduced to stop automatic function of the M16A1 weapon.

Change in Gas Tube Weight - Gas tube weight generally increased at the same rate in all weapons - about 0.6 gram per 4000 rounds fired. However, the rate at which a gas tube gains weight is not always a reliable measure of reduction in effective cross-sectional area of the tube since some gas tubes in other weapons fired in this study increased rapidly at first but then remained constant or lost weight in the course of firing the remainder of the 10,000 rounds.

Cyclic Rate - Cyclic rates followed a pattern of decreasing as flow meter measurement increased and gas tube weight increased. After the weapons stopped due to insufficient gas flow through the gas tubes and new tubes were placed in the weapons, cyclic rate assumed a new high level and followed the same pattern of reduction until the gas tubes again blocked due to fouling.

It is of interest to note that 100 rounds of ammunition lot TW18179 were inadvertently fired in rifle 9 (861015) at a time when the gas tube had accumulated heavy fouling from ammunition RA5320. It was noted that the cyclic rate immediately jumped from a level of approximately 650 rds/min to a level in excess of 900 rds/min. This was surprising since ammunition loaded with IMR propellant usually produces lower cyclic rates than ammunition loaded with ball propellant. It could be that the IMR propellant caused a purging effect on the gas tube.

Malfunctions - As heavy fouling developed in the gas tube, malfunctions increased noticeably. Reduction in effective cross-sectional area of the gas tube due to fouling caused the cyclic rate to lower, with the result that the weapon approached a lower limit of satisfactory function. At this point excessive malfunctions were experienced. These malfunctions were distributed among FF, FJ, FS, FX, and FBR.*

* See legend, Table III.

Rifles 10 (862235), 11 (863323), 12 (863632); Propellant Lot TW18191
(Figure 5)

Flow Meter Readings - Flow meter readings in all three rifles increased somewhat during firing of the first 1000 rounds. These readings decreased slightly, but remained generally constant for the remainder of the test. There were no weapon stoppages due to gas tube fouling and the flow meter readings were within normal operating limits.

Change in Gas Tube Weight - With each rifle, the gas tube increased in weight and gradually lost some of this initial weight gain during the test. It appears that all three gas tubes accumulated an initial fouling quantity and then gradually lost some of it in the continuing firing program.

Cyclic Rate - Weapon cyclic rate increased from about 700 rds/min to about 770 rds/min in the course of firing the 10,000-round endurance test. This rate of firing is within the acceptable firing rate limits.

Malfunctions - There was no particular trend in the development of malfunctions for this lot of ammunition in any of the three rifles. The malfunctions obtained were not associated with gas tube clogging. They were associated with either magazine malfunctions or probably high or low bolt accelerations resulting from individual cartridges.

X-ray Photographs

A series of photographs showing the build-up of fouling in the gas tubes is presented in Appendix E. The importance of these photographs is that they provide a visual observation of the manner in which the fouling coats the inside of the tube.

There appear to be two general distinctions between the deposits from ball and IMR propellant. The fouling deposits from ball propellant tend to accumulate near the port end of the gas tube, whereas the deposit from IMR seems to accumulate evenly along the entire length of the tube.

A spectrographic analysis of the fouling deposit is shown in Appendix F. This analysis is approximate, and covers the

metals present. It is by no means complete, but it does indicate one important aspect of the problem, i. e., that copper, lead, iron, and calcium form a considerable part of the fouling. This analysis does not indicate the proportion of organic constituents that are or could be present from the propellant.

CONCLUSIONS

It is concluded that for these tests:

1. The performance of the weapons and lots of ammunition used in these tests varied with respect to fouling deposited in the gas tube and energy delivered to the bolt carrier.
2. Fouling of the gas tube of the M16A1 rifle did occur and the degree of fouling was dependent upon the combination of rifle and cartridge lots tested.
3. Gas tube fouling varies in degree and location, depending upon propellant type and lot. WC846 propellant produced more localized deposits of fouling behind the front plug of the gas tube and from the port rearward for a distance of approximately 3 to 4 inches. IMR 8208M propellant produced deposits which were less localized and extended over a greater length of the tube. Regardless of the type of fouling deposition encountered, the result is the same; namely, reduction in effective cross-sectional area of the gas tube. The amount or degree of gas tube fouling can be effectively measured or observed by flow measurement, x-ray, and weighing of the gas tube. Of these, flow measurement is the quickest and most indicative technique since it gives a quantitative measure of ability of the gas tube to function properly.
4. Fouling of the gas tube of the M16A1 rifle produces significant effects on weapon cyclic rate which, at a certain point, will further result in increased malfunction rate. The malfunction rate increased rapidly when the cyclic rate dropped below approximately 600 rd/min. Higher malfunction rates were also encountered when the cyclic rate exceeded approximately 950 rd/min.

5. With rifle/cartridge lot combinations utilizing ammunition lot RA5320 containing WC846 propellant, sufficient fouling was consistently deposited in the gas tubes to prevent proper functioning of the weapon.

6. The quantity of fouling deposited with rifle/cartridge combinations utilizing ammunition lot RA5244, also containing WC846 propellant, was not sufficient to adversely affect the functioning of the M16A1 rifles in which it was fired.

7. Rifle/cartridge lot combinations utilizing ammunition lot TW18179 with IMR 8208M propellant resulted in no appreciable deposit of fouling in the gas tube of the rifles in which it was fired.

8. Rifle/cartridge lot combinations utilizing ammunition lot TW18191 with IMR 8208M propellant likewise resulted in no appreciable deposit of fouling in the gas tube of the rifles in which it was fired.

RECOMMENDATIONS

It is recommended that:

1. Investigation of cartridge lots and propellant lots be made to determine fouling tendencies when ammunition is used in the M16A1 rifle.

2. Tests be made to determine weapon influence in combination with cartridge lot and propellant lot with respect to fouling characteristics.

APPENDIX A

DESCRIPTION OF FLOW MEASUREMENT INSTRUMENT

A half-bridge type flow measurement instrument was also developed to measure flow characteristics through the gas tube. A schematic diagram and photograph of this device is shown in Figure A1. In this instrument the pressure drop through the rifle is compared with the pressure drop through a fixed restrictor.

In order to reduce the data to some physically meaningful parameter which can be compared with any subsequent test procedure, a discharge coefficient (C_D) has been calculated. This coefficient is defined as the ratio of actual mass flow rate to ideal flow rate if the air were expanded isentropically through a 1/8-inch diameter nozzle from the condition at the rifle muzzle to atmospheric pressure. (This assumes that the supply pressure is low enough so that sonic choking does not occur.)

Figure A2 relates the "B" pressure from the test device to this discharge coefficient and to the times recorded in the fixed volume type flow apparatus. These are the "B" pressures for a 4 psi supply pressure. The values of these variables that have general significance for the rifles tested are shown on the graph.

Operating Instructions

1. Turn pressure regulator screw until it no longer presses on diaphragm in regulator. (This is to protect against over-loading meter.) Connect air supply to unit.
2. Retract bolt on M16A1 rifle, insert chamber plug, and allow bolt to return, pressing on rear of chamber plug. Chamber plug is stored in a rack inside the unit.
3. Remove flash suppressor from rifle and clean threads with a brass brush. Place O-ring over rifle muzzle threads making sure O-ring is in good condition. Put silicone grease on the O-ring.
4. Screw adapter on rifle muzzle.

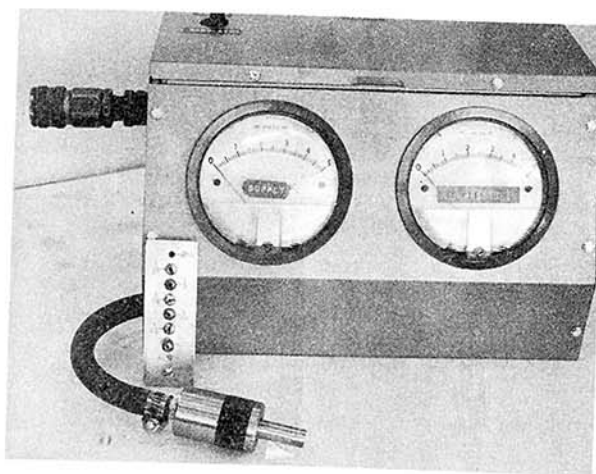
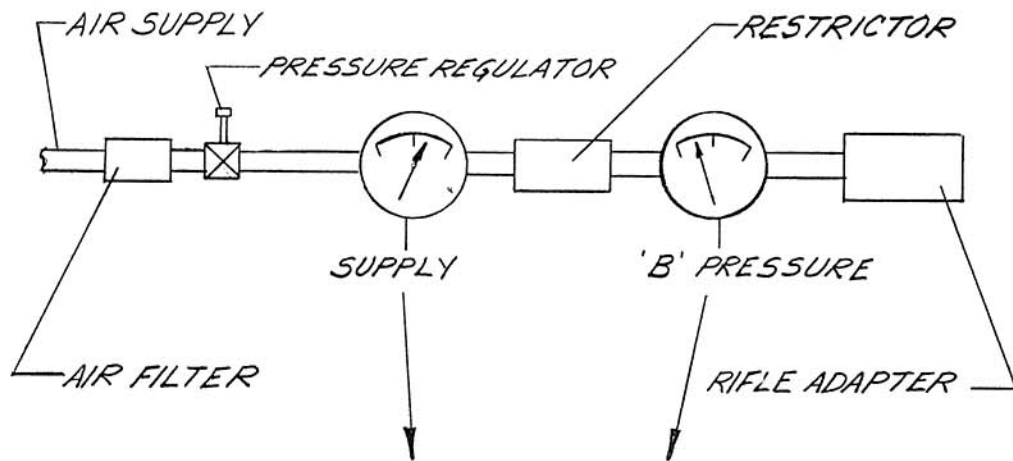

← RIFLE ADAPTER

Figure A1. Schematic diagram and photograph of Half-Bridge Type Flow Measurement Instrument

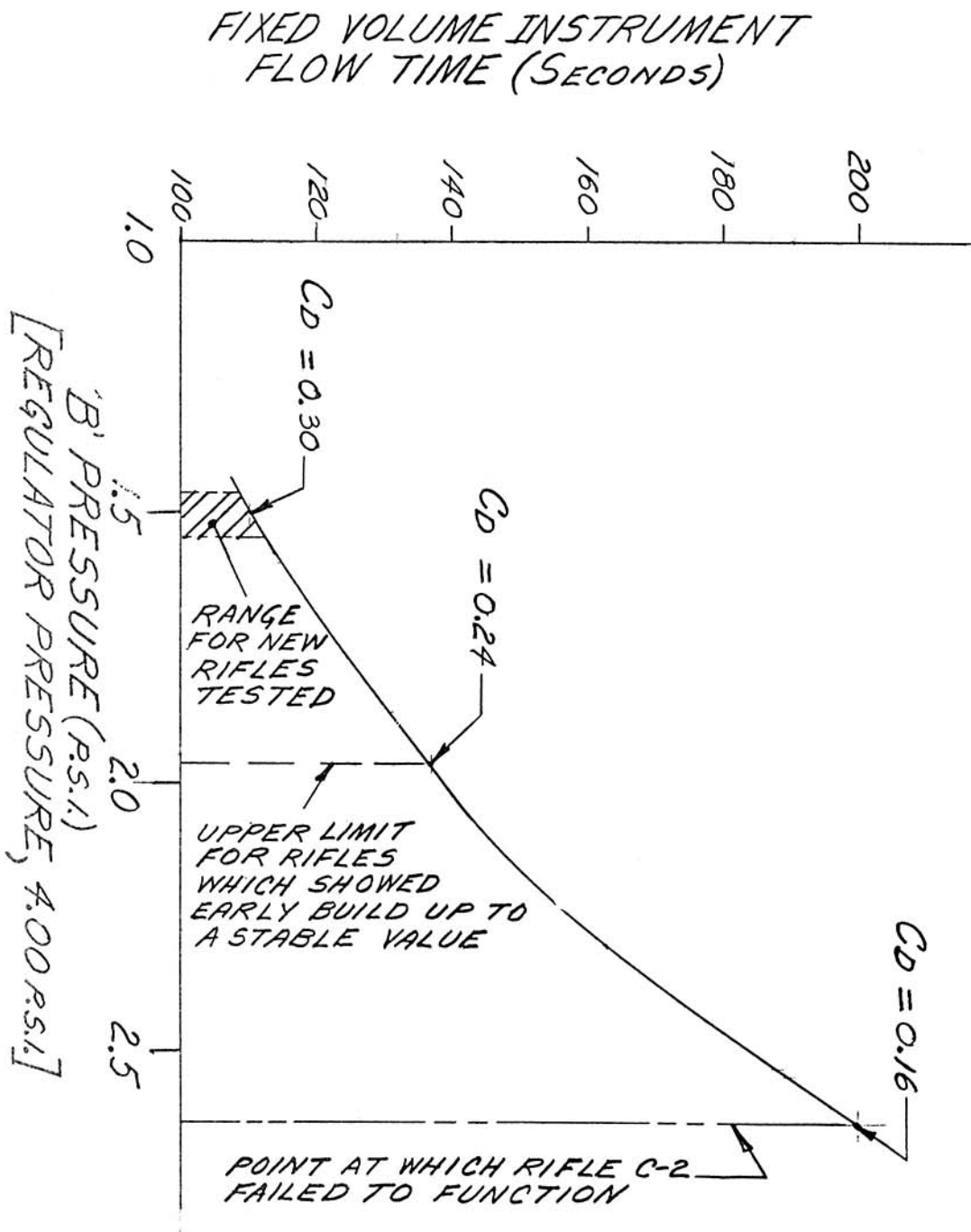

Figure A2. Fixed Volume Flow Times vs "B" Pressure, with Some Values of Discharge Coefficient

5. Set supply pressure at exactly 4 psi with pressure regulator control. Check for air leaks around muzzle adapter.
6. Read "B" pressure to the nearest 0.01 psi.
7. Return supply pressure to zero.

Periodically check instrument with the calibration orifice which should give a "B" pressure of 1.68 ± 0.05 psi when the above procedure is followed.

Maintenance

1. Periodically check O-rings on chamber plug.
2. Periodically check air filter.
3. Periodically check for leaks in adapter seals and replace O-rings if necessary.

APPENDIX B

AMMUNITION LOT INSPECTION REPORTS

RD 1598 Rev. 4

K

EMINGTON ARMS COMPANY, INC.
BRIDGEPORT, CONNECTICUT

Quantity Packed: 996,000 AMMUNITION LOT INSPECTION REPORT LOT NO.: RA-5244

ITEM: CARTRIDGE, BALL, 5.56 MM M193 CONTRACT NO.: DA-36-038-AMC-3694 (A)
Spec. No.: MIL-C-9963D Date: 1 June 1964 Amend No.: --- Date: ---
Drawing No.: E-10523632 Date: 26 June 1963 Rev. No.: C Date: 23 October 1964
Case: Steel Brass Head Stamp: (Year) 1966 Fed. Stock No.: 1305-062-369-A066
Primer: 924 Mix: 5067 Primer Lot Nos.: RA2-364, 365, 866, 867, 869, 870, 871, 872
Propellant: Western Ball WC-214 ~~XXXX~~ LOT NO.: 873 Charge: 28.10 grs.
Loading Dates: Nov. 7 thru 12, 1966 Bull. Jkt. GM GMCS

BALLISTIC TESTS

OTHER TESTS

	BALLISTIC TESTS			OTHER TESTS			
	ROUNDS	RECORD	LIMIT	ROUNDS	RECORD	LIMIT	
VELOCITY (fps)				BULLET EXTRACTION	25	115	35min
Normal - Temp. 70° ± 2°F.	20			MERCURY CRACK	50	0	0
Corr. Mean @ 15 ft.		3240	3250±40	WATERPROOF	50	0	3
Standard Deviation		22'	40' Max.				
High Temperature				VISUAL, GAGE & WEIGH INSPECTION			
125°F. - 4 hrs.	10	+23	-250	Sample Size			
160°F-4 hrs. then 70°-6 hrs.	10	-4	-250	15,625	Crit.	MAJOR	MINOR
Low Temperature				Accept. Qual. Level	0.0	0.25	1.50
-65° - 6 hrs.	20	-199	-250	% Defective	0.0	0.00	0.02
PRESSURE (CHAMBER)(psi)				DEFECTS			
Normal-Temp. 70°±2°F.	20			Ring on bullet			1
Max. Ave.		45,700	52,000 Max.	Dirty primer			1
Max. Ave. + 3s		50,416	58,000 Max.	No pr. waterproof			1
High Temperature				TOTAL			3
125° - 4 hrs.	10	+100	+5,000				
160°F-4hrs. then 70°F.-6 hrs.	10	-700	+5,000	PACKING INSPECTION			
Low Temperature							
-65°F. - 6 hrs.	20	-6200	+5,000				
PRESSURE PORT (psi)	20	15,535	15,000 ±2,000				
ACTION TIME (milliseconds)	50	1.19	4 max.				
ACCURACY - (M.R. @ 200 yds.)	90	1.39"	2.00" max.				
FUNCTION & CASUALTY							
AR 15 Rifle Ambient	240	OK		Container Contents	0.0	1.0	0.0 2.5
" " " -High	240	OK		Packed Container	0.0	1.0	0.0 2.5
" " " -Low	240	OK		Leak Test	0.0	1.0	0.0 2.5
CASUALTIES				Overpack	0.0	1.0	0.0 2.5
None				Overpack-telescope	---	4.0	---- 10.0
				Port Pressure Variation			
				125°F. +135			
				160°F. +75			
				-65°F. -515			

Packed: 20 rds/ctn
720 rds/24AL box
1440 rds/wirebound crate
43200 rds/pallet
780 cases-1000 rds/fiber case

Primer Sensitivity
H + 3s -11.80-11.78-11.15-11.77-10.91-10.56-9.91-10.63
H - 3s - 4.84-4.70-4.25-4.27-3.47-3.42-4.69-3.97

This Lot of Ammunition Has Met All Requirements For Acceptance.

Contractor Representative

Date

Ordnance Representative

Date

Date Presented 9 June 1967
 Quantity Packed 2,423,920 Rds.
 FSN 1305-926-3970-A066*

Functional Lot Nos. R

AMCMS Code 4810016.0217.2.c4*

Spec. No. MIL-C-9963-D Rev. Amend. 2
 ECO _____ Date _____
 Dwg. No. D10523632
 Rev. D Date 2-17-65

TWIN CITIES ARMY AMMUNITION PLANT
 INSPECTION REPORT - 5.56MM

ITEM Ctg. 5.56mm Ball M193
 Lot No. TW-18191

Accepted Ist Test
 Rejected Retest
 Waiver

Acceptance Date 14 June 1967

Contractor: Federal Cartridge Corp.
 Contract No. DA-36-038AMC-1099(A)
 Primer No. PA-84-038/AMC-1099(A) 195
 Primer Lot Nos. 212A-B 211 A-B

Tracer Mix _____
 Igniter Mix _____
 Propellant Type TMR:8202
 A.L. No. 44635
 Chg. (Grs) 25.7
 Case - Steel Brass
 Headstamp (Yr) 1967
 Bullet Jacket Gilding Metal

FIRING TESTS				
CHAMBER PRESSURE (PSI)	AMB	125°	160°	-65°
RDS FIRED	20	10	10	20
RECORD	<u>49,600</u>	<u>-200</u>	<u>-1600</u>	<u>-6400</u>
LIMIT - MAX	52,000	+ 5,000	+ 5,000	+ 5,000
AVG + 3 SD	<u>53,500</u>			
LIMIT - MAX	58,000			
PORT PRESSURE (PSI)				
RECORD	<u>13,190</u>	<u>0</u>	<u>+130</u>	<u>-1160</u>
LIMIT	15,000 ± 2,000	+ -2,000	+ -2,000	+ -2,000
VELOCITY @ 15 FT. (FS)				
RDS FIRED	20	10	10	20
RECORD	<u>3215</u>	<u>+79</u>	<u>77</u>	<u>-195</u>
LIMIT - BALL	3250 ± 40	-250	-250	-250
LIMIT - TRACER	3200 ± 40	-250	-250	-250
STD DEV	<u>18.6</u>			
LIMIT	40			
ACCURACY (INCHES)		RDS FIRED	RECORD	LIMIT
MEAN RADII @ 200 YDS		90	<u>1.11</u>	<u>1.50 2.0</u>
ACTION TIME (MS)		50	<u>.98</u>	4.0
FUNCTION & CASUALTY		RDS FIRED	RECORD	LIMIT
RIFLE, 5.56MM, XM16E1		<u>720</u>		
CASUALTIES			<u>none</u>	

TRACE PERFORMANCE	NO. RDS.	RECORD	LIMIT		
TRACING @ 500 YDS.	100		80%		
NO. TOTAL BLINDS					
NO. SHORT TRACE					
NO. LATE TRACE					
WATERPROOF TEST					
NO. TESTED	NO. FAILED	SPEC. LIMIT			
50	0	3			
DESCRIPTION OF DEFECTS					
BULLET EXTRACTION TEST (Lbs.)					
No. Tested	SPEC. MIN.	NO. FAILED	MAX.	MIN.	MEAN
25	35	0	106	50	50
MERCUROUS NITRATE TEST					
NO. TESTED	NO. FAILED		SPEC. LIMIT		
50	0		0		
BASE CLOSURE SEAL TEST					
NO. TESTED	NO. FAILED		SPEC. LIMIT		
			3		
VISUAL GAGE & WEIGH INSPECTION					
1st SAMPLE	2400		DATE 6/9/67		
2nd SAMPLE			CRITICAL	MAJOR	MINOR
AQL %			.04	.25	1.50
% DEFECTIVE			.08 .20		
DEFECT NO. & DESCRIPTION			2/44 2/36 1/5		
TOTAL			2	3	
PACKING INSPECTION - CONTAINER CONTENT					
	MAJOR		MINOR		
SUB-LOT	% DEFECTIVE	AQL %	% DEFECTIVE	AQL %	
		1.0		2.5	
1ST	0		0		
2ND	0		0		
TOTAL AUTHORIZED RDS EXPENDED IN TESTS:			1030		

REMARKS:
 This carton packed lot charged against PRON: F6-7-A0120-01-FO-FN, (10-rd. Clip), authority per SMUAP Form 1018.

_____ A. Anderson _____ L. M. ...
 CHIEF BALLISTICIAN TCAAP Acting - CHIEF, GOVERNMENT QA DIVISION 14 Jun 67

RD 1598 Rev. 4

R

REMINGTON ARMS COMPANY, INC.
BRIDGEPORT, CONNECTICUT

Quantity Packed: 1,108,800 AMMUNITION LOT INSPECTION REPORT LOT NO.: RA-5320

ITEM: CARTRIDGE, BALL, 5.56 MM M193
 Spec. No.: MIL-C-9963D Date: 1 June 1964 Amend No.: 3 Date: 2 November 1966
 Drawing No.: D-10523632 Date: 26 June 1963 Rev. No.: C Date: 23 October 1964
 Case: Steel Brass Head Stamp: (Year) 1967 Fed. Stock No.: 1305-926-3930-A071
 Primer: 92M Mix: 5067 Primer Lot Nos.: RA2-1196,1210,1211,1231,1243,1244,1245
 Propellant: Western Ball WC-846 ~~XXXXXXXXX~~ LOT NO.: 1020 Charge: 28.00
 Loading Dates: Sept. 19 thru 23,25,26,1967 Bull.Jkt. GM GMCS

BALLISTIC TESTS

OTHER TESTS

VELOCITY (fps)	ROUNDS	RECORD	LIMIT	BULLET EXTRACTION	ROUNDS	RECORD	LIMIT
	Normal - Temp. 70° ± 2°F.	20				MERCURY CRACK	25
Corr. Mean @ 15 ft.		3255	3250±40	WATERPROOF	50	0	0
Standard Deviation		17'	40' Max.		50	0	3
High Temperature							
125°F. - 4 hrs.	10	+34	-250				
160°F-4 hrs.then 70°-6 hrs.	10	-38	-250				
Low Temperature							
-65° - 6 hrs.	20	-194	-250				
PRESSURE (CHAMBER)(psi)				VISUAL, GAGE & WEIGH INSPECTION			
Normal-Temp. 70°±2°F.	20			Sample Size			
Max. Ave.		47,500	52,000 Max.	21,025	Crit.	MAJOR	MINOR
Max. Ave. + 3s		52,447	58,000 Max.	Accept. Qual. Level	0.0	0.25	1.50
High Temperature				% Defective	0.0	0.005	0.005
125° - 4 hrs.	10	+500	+5,000	DEFECTS			
160°F-4hrs.then 70°F.-6 hrs.	10	+1000	+5,000	Thin head-gage		1	
Low Temperature				Small ext. groove-gage			1
-65°F. - 6 hrs.	20	-2600	+5,000	TOTAL		1	1
PRESSURE PORT (psi)	20	14,890	15,000 ±2,000	PACKING INSPECTION			
ACTION TIME (milliseconds)	50	1.4	4 max.	660 crates	MAJOR		MINOR
ACCURACY - (M.R. @ 200 yds.)	20	1.48"	2.00" max.	% Def.	AQL	% Def.	AQL
FUNCTION & CASUALTY				Container Contents	0.0	1.0	2.5
AR 15 Rifle Ambient	240	OK		Packed Container	0.0	1.0	2.5
" " -High	240	OK		Leak Test	0.0	1.0	2.5
" " -Low	240	OK		Overpack	0.0	1.0	2.5
CASUALTIES - None				Overpack telescope	0.0	0.0	10.0
				Port Pressure Variation			
				125°F. 485			
				160°F. + 135			
				-65°F. - 365			

Packed: 10 rds/clip
 14 clips/443 bandoleer
 6 bandoleers/4241 box
 2 #2A1 boxes/wirebound crate
 3 crates/pallet

Primer Sensitivity

H + 3s - 10.31-10.63-11.31-11.46-10.20-10.55-10.81
 H - 3s - 3.31-3.36-3.51-3.42-3.48-3.17-3.19

This Lot of Ammunition Has Met All Requirements For Acceptance.

J. C. Thurman
 Contractor Representative

10/16/67
 Date

Joseph J. Collins OAR
 Ordnance Representative
 9 Oct 67
 Date

ORDNANCE CORPS BALLISTIC ACCEPTANCE TEST FOR SMALL ARMS PROPELLENT POWDER							WC 846 Lot 873		
TESTED IN ACCORDANCE WITH SPECIFICATION MIL-P-3984C dated 5 Jan. 1965 and Drawing 10534784 dated 16 July 1965							Let No. _____ Caliber <u>5.56 mm.</u> Type _____ Date <u>Oct. 24, 1966</u>		
PROPELLENT POWDER			GUNS			Proof Fired By _____			
Mfr. <u>Olin Mathieson Chemical Corp.</u>			VEL. RIFLE	VEL. RIFLE	PRESS. GAGE	Bullet Type <u>Rem. M193 Ball</u> Bullet Wt. <u>55</u> Grs. Primer <u>Rem.</u> Cartridge Case <u>Rem.</u> Temperature <u>70</u> °F.			
Lot No. <u>WC 846 Lot 873</u>			Receiver No. <u>121</u>		219				
Made At <u>East Alton, Ill.</u>			Barrel No. <u>11</u>						
Net Wt. of Lot <u>39,000</u> Lbs.			Barrel Length <u>20"</u>		20"				
Charge <u>27.8</u> Grs.			Head Space <u>1.499"</u>		1.499"				
Air Space <u>+ .092</u> Ins.			Time Fired <u>1140</u>		2070				
DATE FIRED	BLEND TEST	GUN OR GAGE NUMBER	NO. OF RODS	CORRECTED MEAN VELOCITY AT 15 FT.	VARIATION IN VELOCITY EXPR. STD. DEV.		CORRECTED PRESSURE MEAN MAX.		
10/20/66	Blend of 6	11	20	3244	78	20	—	—	
	Samples	7	20	—	—	—	45700	48800	
INDIVIDUAL BOX SAMPLES	BOX NO.	GUN NUMBER	NO. OF RODS	UNCORRECTED MEAN VELOCITY AT 15 FT.	MEAN VARI. IN VELOCITY		MEAN VEL. FROM AV. OF ALL BOXES		
	Action Time (milliseconds)			10	Temperature Tests				
	Max.			10	Stored Fired		Max. Changes		
	Av. Indiv.			10	at at		Press. Press. Vel. Press.		
	1.24	1.27	10	10	-65°F. 160°F.	-65°F. 70°F.	45900	15000	-200
		10	10	125°F. 125°F.	47900	+100	+80	+1460	
REMARKS:		Standard Deviation on Pressure = 1800 psi.							
		Port Pressure Test		Actual		Corrected			
			No. Rds.	Av.	Av.				
B-2468 - 9,100 lbs.		55-7-R	20	14,600	15,770				
B-2083 - 29,900 lbs.		WC 846 Lot 873	20	13,780	14,950				
DATE FIRED	LOG NUMBER	CHARGE Grains	GUN OR GAGE NUMBER	NO. OF RODS	MEAN VELOCITY AT 15 FT.	MEAN PRESSURE			
	55-7-R								
10/20/66	Standardization				3243				
	Standard Firing	11	20		3233				
	Correction				+10				
10/20/66	Standardization					48400			
	Standard Firing	7	20			47200			
	Correction					+1200			
THIS LOT PROPELLENT POWDER _____ meets _____ THE BALLISTIC TEST REQUIREMENTS.									
(Signature) <u>J. C. Hess</u>			(Signature) _____						
CONTRACTOR			ORDNANCE CORPS OFFICIAL						
(Signature) _____			TITLE AND INSTALLATION						
ORDNANCE INSPECTOR									

OO FORM 15 Apr. 52 1204	ORDNANCE CORPS PROPELLANT DESCRIPTION SHEET	Supersedes OO Form 1204 dated 1 Jul. 49 which is obsolete.					
U.S. Army Lot No. <u>WC 846 Lot 873</u> of <u>1966</u> Composition No. _____ For <u>5.56 mm. Ball</u>							
Manufactured at: <u>Olin Mathieson Chemical Corp., East Alton, Ill.</u> Packed Weight <u>39,000 lbs.</u>							
Contract No. _____ Date <u>Oct. 24, 1966</u> Specification No. <u>MIL-P-</u> Revision of _____							
B-2468 - 9,100 lbs. <u>NITROCELLULOSE 3984C</u> dated 5 Jan. 1965 and Drawing B-2083 - 29,900 lbs. <u>10534784</u> dated 16 July 1965							
Blend of rework material							
Nitrogen Content Maximum _____ % Minimum _____ % Average _____ %	K. I. Starch Test (65.5° C.) Maximum _____ Mins. Minimum _____ Mins. Average _____ Mins.	Stability Test (135° C.) Maximum _____ Mins. Minimum _____ Mins. Average _____ Mins. Explosion _____ Mins.					
MANUFACTURE OF PROPELLANT							
Total weight of solvent per pound NC _____ Consisting of _____ pounds alcohol and _____ pounds ether per 100 pound solvent. Percentage of remix to whole _____							
TEMPS. °C. From To	PROCESS—SOLVENT RECOVERY AND DRYING	TIMES Days Hours					
The following analyses are an average of two tests.							
TESTS OF FINISHED PROPELLANT							
COMPOSITION				STABILITY AND PHYSICAL TESTS			
Constituent	Formula	Mfr.	Inapr.	120°C.	Mfr.	Inapr.	
Nitroglycerin		9.79		Heat test, S. P.	65		
Dinitrotoluene		0.40		Explosion	300+		
Diphenylamine		0.90		Dust & Foreign Material	0.03		
Dibutyl phthalate		4.98		Web	0.164"		
Methylene Chloride Extract		16.07		Graphite	0.23		
Nitrocellulose		83.02		Burning surface per pound (sq. inches)			
Total volatiles		1.37		Grav. density, of pounds per cu. ft.	1.002		
Moisture & Volatiles		0.97		Specific gravity			
Residual Solvent		0.59		Hygroscopicity			
Calcium Carbonate		0.60 nominal		Nitrogen	13.13		
Sodium Sulfate		0.08 nominal					
GRAIN DIMENSIONS		DIF (INCHES)		FINISHED GRAIN (INCHES)		MEAN VARIATION IN PER CENT OF MEAN DIMENSION	
				Manufacturer	Inspector		
Length (L) Granulation		Opening		% Retained			
Diameter (D)		U.S. #20		0.74			
Diameter of perforations (d)		25		9.59			
Web {	Inner	30		31.47			
	Outer	35		30.77			
	Average	40		25.09			
	Calculated	45		1.84			
Difference between inner and outer web in per cent of web average		50		0.16			
		Pan		0.07			
L:D (Y)		Total		99.73			
D:d (X)							
Date packed <u>10/18/66</u>		Date offered _____		Date sampled <u>10/19/66</u>			
Date test finished <u>10/21/66</u>		Date description sheets forwarded <u>10/25/66</u>					
Type of Packing Box <u>Fiber Pak</u>							
Remarks: <u>This lot meets the requirements of MIL-P-3984C dated 5 Jan. 1965 and Drawing 10534784 dated 16 July 1965 with exceptions as noted in the applicable contract.</u>							
Superintendent <u>PE Rangel</u>		Inspector of Ordnance			U. S. Chemist		

Date Presented	9 June 1967	TWIN CITIES ARMY AMMUNITION PLANT INSPECTION REPORT - 5.56MM	Contractor: Federal Cartridge Corp.
Quantity Packed	2,423,920 Rds		Contract No. DA-36-038AMC-1099(A)
FSN	1305-926-3970-A066*		Primer No. 1305-926-3970-A066 / 11111195
Functional Lot Nos.			Primer Lot Nos. 212A-B 211 A-B
AMCMS Code	4810.16.0217.2.04*	ITEM Ctg. 5.56mm Ball M193	Tracer Mix
Spec. No.	MIL-C-9963-D Rev. Amend. 2	Lot No. TW-18191	Igniter Mix
ECO	Date	Accepted <input checked="" type="checkbox"/> 1st Test <input checked="" type="checkbox"/>	Propellant Type TMR 8292
Dwg. No.	D10523632	Rejected <input type="checkbox"/> Retest <input type="checkbox"/>	A.L. No. 44635
Rev'D	Date 2-17-65	Waiver <input type="checkbox"/>	Chg. (Grs) 25.7
		Acceptance Date 14 June 1967	Case - Steel <input type="checkbox"/> Brass <input checked="" type="checkbox"/>
			Headstamp (Yr) 1967
			Bullet Jacket Gilding Metal

FIRING TESTS				
CHAMBER PRESSURE (PSI)	AMB	125°	160°	-65°
RDS FIRED	20	10	10	20
RECORD	49,600	-200	-1600	-6400
LIMIT - MAX	52,000	+5,000	+5,000	+5,000
AVG + 3 SD	53,500			
LIMIT - MAX	58,000			
PORT PRESSURE (PSI)	13,190	0	+130	-1160
RECORD	13,190	0	+130	-1160
LIMIT	15,000 ±2,000	+2,000	+2,000	+2,000
VELOCITY @ 15 FT. (FS)				
RDS FIRED	20	10	10	20
RECORD	3215	+79	-7	-195
LIMIT - BALL	3250 ± 40	-250	-250	-250
LIMIT - TRACER	3200 ± 40	-250	-250	-250
STD DEV	18.6			
LIMIT	40			

ACCURACY (INCHES)	RDS FIRED	RECORD	LIMIT
MEAN RADII @ 200 YDS	90	1.11	sl/2.0
ACTION TIME (MS)	50	.98	4.0
FUNCTION & CASUALTY	RDS FIRED	RECORD	LIMIT
RIFLE, 5.56MM, XM16E1	720		
CASUALTIES		None	

TRACE PERFORMANCE	NO. RDS.	RECORD	LIMIT
% TRACING @ 500 YDS.	100		80%
NO. TOTAL BLINDS			
NO. SHORT TRACE			
NO. LATE TRACE			

WATERPROOF TEST		
NO. TESTED	NO. FAILED	SPEC. LIMIT
50	0	3

BULLET EXTRACTION TEST (Lbs.)					
No. Tested	SPEC. MIN.	NO. FAILED	MAX.	MIN.	MEAN
25	35	0	106	50	50

MERCURIUS NITRATE TEST		
NO. TESTED	NO. FAILED	SPEC. LIMIT
50	0	0

BASE CLOSURE SEAL TEST		
NO. TESTED	NO. FAILED	SPEC. LIMIT
		3

VISUAL GAGE & WEIGH INSPECTION			
1st SAMPLE	2400	DATE 6/9/67	
2nd SAMPLE			
AQL %		CRITICAL .04	MAJOR .25
% DEFECTIVE			MINOR 1.50
DEFECT NO. & DESCRIPTION			.20
		2/44	2/16
			1/5
TOTAL		2	3

PACKING INSPECTION CONTAINER CONTENT				
SUB-LOT	MAJOR		MINOR	
	% DEFECTIVE	AQL %	% DEFECTIVE	AQL %
		1.0		2.5
1ST	0		0	
2ND	0		0	
TOTAL AUTHORIZED RDS EXPENDED IN TESTS:				1030

REMARKS:

APPENDIX C

PROPELLANT CERTIFICATION REPORTS

CO FORM 15 Apr. 52 1204	ORDNANCE CORPS PROPELLANT DESCRIPTION SHEET	Supersedes OO Form 1204 dated 1 Jul. 49 which is obsolete.
----------------------------	---	--

U.S. Army Lot No. _____ of 1967 Composition No. _____ For 5.56 mm.
WC 846 Lot 1020
 Manufactured at: Olin Mathieson Chemical Corp., East Alton, Ill. Packed Weight 40,300 lbs.
 Contract No. B-11145 Date Aug. 16, 1967 Specification No. MIL-P- Revision of _____

Accepted blends (Nos.) _____ NITROCELLULOSE 3984C dated 5 Jan. 1965 and Drawing 10534784 dated 16 July 1965
Blend of rework material

Nitrogen Content	K. I. Starch Test (65.5° C.)	Stability Test (135° C.)
Maximum _____ %	Maximum _____ Mins.	Maximum _____ Mins.
Minimum _____ %	Minimum _____ Mins.	Minimum _____ Mins.
Average _____ %	Average _____ Mins.	Average _____ Mins.
		Explosion _____ Mins.

MANUFACTURE OF PROPELLANT

Total weight of solvent per pound NC _____ Consisting of _____ pounds alcohol and _____ pounds ether per 100 pound solvent. Percentage of remix to whole _____

TEMPS., °C.		PROCESS—SOLVENT RECOVERY AND DRYING	TIMES	
From	To		Days	Hours

The following analyses are an average of two tests.

TESTS OF FINISHED PROPELLANT

COMPOSITION				STABILITY AND PHYSICAL TESTS		
Constituent	Formula	Mfr.	Inspr.	120° C.	Mfr.	Inspr.
Nitroglycerin		10.48		125° C heat test, S. P.	75	
Dinitrotoluene		0.57		Explosion	300+	
Diphenylamine		1.10		Form of grain	Dust & Foreign Material, 0.3	
Dibutyl phthalate		4.74		No. of perforations	Web .0165"	
Methylene Chloride Extract		16.89		No. of grains per pound	Graphite .21	
Nitrocellulose		82.22		Burning surface per pound (sq. inches)		
Total volatiles		1.22		Grav. density, 30 pounds per cu. ft.	.997	
Moisture & Volatiles		0.95		Specific gravity		
Residual Solvent		0.52		Hygroscopicity		
Calcium Carbonate		0.60	nominal	Compression test	Nitrogen 13.08	
Sodium Sulfate		0.08	nominal			

GRAIN DIMENSIONS		DIE (INCHES)	FINISHED GRAIN (INCHES)		MEAN VARIATION IN PER CENT OF MEAN DIMENSION	
			Manufacturer	Inspector	Manufacturer	Inspector
Length (L)	Granulation		Opening	% Retained		
Diameter (D)			U. S. # 20	0.07		
Diameter of perforations (d)			25	1.14		
Web	Inner		30	14.33		
	Outer		35	63.63		
	Average		40	18.74		
	Calculated		45	0.85		
Difference between inner and outer web in per cent of web average			50	0.39		
L:D (Y)			Par	0.66		
D:d (X)			Total	99.81		

Date packed 8/8/67 Date offered _____ Date sampled 8/8/67
 Date test finished 8/10/67 Date description sheets forwarded 8/17/67
 Type of Packing Box Fiber Pak

Remarks: This lot meets the requirements of MIL-P-3984C dated 5 Jan. 1965 and Drawing 10534784 dated 16 July 1965 with exceptions as noted in the applicable contract

Supervisor <i>P. Keizer</i>	Quality Control	Inspector of Ordnance U. S. Chemist
--------------------------------	-----------------	--

**ORDNANCE CORPS
BALLISTIC ACCEPTANCE TEST
FOR
SMALL ARMS PROPELLENT POWDER**

Lot No. WC 846 Lot 1020
Caliber 5.56 mm.
Type _____
Date Aug. 16, 1967

MIL-P-3984C dated 5 Jan.

TESTED IN ACCORDANCE WITH SPECIFICATION 1965 and Drawing 10534784 dated 16 July 1965

PROPELLENT POWDER		GUNS			Proof Fired By _____
Mfr. <u>Olin Mathieson Chemical Corp.</u>		VEL. RIFLE	VEL. RIFLE	PRESS. GAGE	Rem. M193 Ball
Lot No. <u>WC 846 Lot 1020</u>		121		32	Bullet Type _____
Made At <u>East Alton, Ill.</u>	Receiver No. _____	15		11	Bullet Wt. <u>55</u> Grs.
Net Wt. of Lot <u>40,300</u> Lbs.	Barrel No. _____	20"		20"	Primer <u>Rem.</u>
Charge <u>27.8</u> Grs.	Barrel Length _____	1.499"		1.499"	Cartridge Case <u>Rem.</u>
Air Space <u>+1.02</u> In.	Head Space _____	2210		1960	Temperature <u>70</u> °F.
	Times Fired _____				

DATE FIRED	BLEND TEST	GUN OR GAGE NUMBER	NO. OF RODS	CORRECTED MEAN VELOCITY AT 15 FT.	VARIATION IN VELOCITY		CORRECTED PRESSURE	
					EXTR.	STD. DEV.	MEAN	MAX.
8/9/67	Blend of 6	15	20	3258	64	17	—	—
	Samples 11	11	20	—	—	—	47500	49500
	INDIVIDUAL BOX SAMPLES	BOX NO.	GUN NUMBER	NO. OF RODS	UNCORRECTED MEAN VELOCITY AT FT.	MEAN VARI. IN VELOCITY		MEAN VEL. FROM AV. OF ALL BOXES
				10	Temperature Tests			
			Action Time (milliseconds)	10	Stored Fired Max. Indiv. Changes Port			
			Max.	10	at at Press. Press. Vel. Press			
			Av. Indiv.	10	-65°F. -65°F. 48700 -900 -161 -720			
			1.04 1.07	10	60°F. 70°F. 50600 -200 +18 -30			
		10	25°F. 125°F. 53500 +2800 +100 +170					

REMARKS

Standard Deviation on Pressure - 1100 psi.

Port Pressure Test

B-11145

55-8R
WC 846 Lot 1020

No. Rds.	Actual Av.	Corrected Av.
20	14,620	15,100
20	15,300	15,780

DATE FIRED	LOG NUMBER	CHARGE	GUN OR GAGE NUMBER	NO. OF RODS	MEAN VELOCITY AT 15 FT.	MEAN PRESSURE
	55-8R	Grains				
	Standardization				3249	
8/9/67	Standard Firing		15	20	3229	
	Correction				+20	
	Standardization					46100
8/9/67	Standard Firing		15	20		44700
	Correction					+1400

THIS LOT PROPELLENT POWDER _____ meets _____ THE BALLISTIC TEST REQUIREMENTS.

(Signature) D. R. Zaidan
CONTRACTOR

(Signature) _____
ORDNANCE CORPS OFFICIAL

(Signature) _____
ORDNANCE INSPECTOR

TITLE AND INSTALLATION

E. I. DU PONT DE NEMOURS & CO. (INC.)
EXPLOSIVES DEPARTMENT--CARNEYS POINT WORKS
SMOKELESS POWDER--CERTIFICATION OF TESTS

Contract No. DA-36-038-AMC-4326/A/	Govt. Lot No. 44635 of 1966
Date Shipped C 12/15/66	Powder Type DU PONT IMR-8208M
Weight Shipped, Lbs.	Du Pont Lot No. 16
Du Pont Order No. CD-7866	For 5.56MM M-193 Ball
Customer Order No.	Manufactured at Carney's Point, N. J.
Specification No. MIL-P-3984C, 1/5/65	Date Packed 11/30/66
Incl. Amend. 3, 3/24/66	Packed Weight, Lbs. 35,200
Incl. Drawing 10535450, 4/29/66 and EO-S60251	Type Container Fiber Paks at 100# each

	Formula	Maximum	Minimum	Analysis
Nitrocellulose, %	100.0			94.54*
Diphenylamine (added), %	0.7	1.25	0.50	0.65*
Potassium Sulphate (added), %	1.0	1.00	0.10	0.78*
Dinitrotoluene (coated), %				
Ethylene Dimethacrylate (coated), %		8.0	2.0	3.69*
Graphite (glazed), %		0.4		0.34*
Tin, %				
Dibutylphthalate, %				
Potassium Nitrate, %				
Barium Nitrate, %				
Barium Carbonate, %				
Total Volatiles, %		2.35		1.56
Moisture, %		1.25	0.75	1.13(6/55)
Residual Solvent, %		1.10		0.43
Ash, %				0.12
Hygroscopicity, %		1.80		1.69
MVP Test at 134.5°C., Mins.			40'	100
Explosion Test at 134.5°C., Hrs.			5	5+
Bulk Density		0.905	0.865	0.902
Dust & Foreign Matter, %		0.10		0.01
Form of Grain				Cylindrical
No. of Perforations				1
Dimensions: l	1/32	0.031	0.027	0.028
(Inches) D	0.041**	0.029	0.025	0.026
d	0.010	0.006	0.004	0.004
Web		0.013	0.009	0.010
Grains/Lb.				1.026.244
Burning Surface/Lb. (sq. in.)				3.764

REMARKS:

*On volatiles-free basis.

**About 25% of this lot was granulated on the 0.043" die.

CERTIFICATION

I certify that the material or product described in this report has been inspected and/or tested as stated herein, that such specimens or samples as have been inspected or tested were taken from the lot or quantity described herein, and that the results of these inspections and tests are as shown.

Manager: E. O. RANDOLPH, JR.Per: Neil C. Miller *AKBR*Typdate: 12/13/66

U. S. GOVERNMENT PRINTING OFFICE: 1964
EXPLOSIVES DEPARTMENT--CARNEY'S POINT WORKS

SMOKELESS POWDER--DESCRIPTION SHEET--U. S. GOVERNMENT

Date Sampled	11/30/66	Gov. Lot No.	44633 of 1966
Date Test Finished		Powder Type	DU PONT IMR-8208M
Date Desc. Shts. Forwarded		Du Pont Lot No.	16
Du Pont Order No.	CD-7866	For	5.56 MM M-193 Ball
Customer Order No.		Manufactured at	Carney's Point, N. J.
Specification No.	MIL-P-3984C, 1/5/65	Date Packed	11/30/66
Incl. Amend.	3, 3/24/66.	Packed Weight, Lbs.	35.200
Incl. Drawing	10535450, 4/29/66 and EO-S60251	Type Container	Fiber Paks at 100# each
		Contract No.	DA-36-038-AMC-4326/A/

NITROCELLULOSE BLENDS

2145, 2157, 2158, 2159, 2161,
2162, 2163, 2164, 2165, 2190,
2191, 2192, 2193

CHEMICAL AND PHYSICAL TESTS

	Formula	Analysis
Nitrocellulose, %	100.0	94.54*
Diphenylamine (added), %	0.7	0.65*
Potassium Sulfate (added), %	1.0	0.78*
Dinitrotolane (added), %		
Ethylene Diamineacrylate (added), %	4.70	3.69*
Graphite (glazed), %	0.15	0.34*
Fe, %		
Dibutylphthalate, %		
Potassium Nitrate, %		
Barium Nitrate, %		
Barium Carbonate, %		

NITROCELLULOSE ANALYSIS

	Max.	Min.	Avg.
Nitrogen, %	13.19	13.13	13.16
KI-Starch Test, Mins.	38	36	37
MVP Test at 134.5°C., Mins.	30	30	30

SOLVENT

Lbs. per 100 lbs. dry NC	92
Consisting of, per 100 lbs. of Solvent:	
Lbs. Ethyl Ether	65
Lbs. Ethyl Alcohol	35

Total Volatiles, %	1.56
Moisture, %	1.13(6/55)
Residual Solvent, %	0.43
Ash, %	0.12
Hygroscopicity, %	1.69
MVP Test at 134.5°C., Mins.	100
Explosion Test at 134.5°C., Hrs.	5+
Granulometric Density	902
Burn & Resign Method, %	0.01
Form of Grain	Cylindrical

PROCESS	TIME		TEMP. °C.	
	Days	Hours	From	To
Boiled in Still				
Solvent Recovery		20	35	55
Water Drying, Before Cooling	5			60
Water Drying, After Cooling				
Air Drying		12-14		55

REMARKS:

No. of Particulations		1
Dimensions	L	1/32
	D	0.041**
	d	0.010
	Web	0.0110
Grain/lb.		1,026,244
Grain Surface/lb. (sq. in.)		3,764

*On volatiles-free basis.

**About 25% of this lot was granulated through 0.043" die.

Manager: E. O. RANDOLPH, JR.

Prep: *W. C. Miller*

Date: 12/13/66

**BALLISTIC ACCEPTANCE TEST
FOR
SMALL ARMS PROPELLANT POWDERS**

CARTRIDGE			BARRELS			POWDER					
Case	REFERENCE	TEST LOT	Number	VELOCITY	PRESSURE	PORT PRESSURE	Lot 44635 (DuP 16)				
Case	RA-Loaded	TC	1280	1286	1286		Cal. 5.56MM M193 Ball				
Primer	Ammunition	Factory	Piston	None	Short	Short	Type IMR-8208M				
Bullet	Lot RA-5050	TCBallM193	Length				Mfg. By DU PONT				
Bullet Wt.		55 Gr.	Head Space				Mfg. At CARNEYS PT.				
TEST EQUIPMENT			Times Fired				Weight 35,200#				
Chron	Counter		Receiver	FA	FA	FA	Packed 11/30/66				
Target	Lumiline		Fir. Pin Pro.				G.D. 902				
Range Temp., °F			Fir. Pin Ind.				Efficiet 1.13%(6/55)				
REFERENCE POWDER FIRINGS, LOT RA-5050											
					VELOCITY AT 15 FT.			PRESSURE, psi			
		SSL.	CHG.	AS	RDS.	MEAN	EV	SD	MEAN	SD	MAX.
Velocity Firing	Assessment					3244					
12/1/66	Today's Firing	1280			20	3217					
	Correction					+ 27					
Chamber Pressure Firing	Assessment								45000		
12/6/66	Today's Firing	1286			20				43900		
	Correction								+1100		
Port Pressure Firing	Assessment								15900		
12/6/66	Today's Firing	1286			20				15500		
	Correction								+ 400		
TEST RESULTS, LOT IMR-8208M, Govt. Lot 44635 (Du Pont Lot 16)											
Velocity Firing											
12/1/66		1280	26.3	0.03c	20	3205		19.0			
	Velocity Correction					+ 27					
	Corrected Velocity					3232					
	Spec. Req.					3250	±20	26.0 (Max.)			
Chamber Pressure Firing											
12/1/66		1286	26.3	0.03c	20				47600		
	Chamber Pressure Correction								+1100		
	Corrected Chamber Pressure								48700		
	Specification Requirement (Maximum)								50000		
Port Pressure Firing											
12/1/66		1286	26.3	0.03c	20				14300		
Action Time, milliseconds											
	Average	1.06							+ 400		
	Max. Ind.								14700		
	S.D.								15000	±2000	
	S.D. × 4										
	Ave. ± 4SD										
	Spec. Limit (Max.)	2.5									
Pressure, psi											
	Average										
	S.D.										
	S.D. × 3										
	Ave. ± 3SD										
	Spec. Limit										
THIS LOT OF POWDER DOES MEET THE REQUIREMENTS OF SPEC. MIL-P-3984C, 1/5/65 incl. Amend. 3, 3/24/66, and Drawing 10535450, 4/29/66 and EO-S60251											
All test cases waterproofed and crimped.											
E. I. du Pont de Nemours & Co. (Inc.) Carneys Point Works Manager E. O. RANDOLPH, JR. By <i>Thos. C. ...</i> Date: 12/13/66											

U. S. GOVERNMENT PRINTING OFFICE: 1963
EMPLOYED DEPARTMENT
GARRETS POINT WORKS

TEMPERATURE TESTS—GOVERNMENT RIFLE POWDER

CASE	LOT NO. <u>44635 (Du Pont 16)</u>
MFR. <u>Twin Cities</u>	CALIBER <u>5.56 MM M-193 Ball</u>
PRIMER <u>Factory</u>	TYPE <u>IMR-8208M</u>
REC'D _____	DATE of Test <u>12/7/66 to 12/10/66</u>
BULLET	G. D. <u>902</u>
MFR. <u>Twin Cities</u>	MOISTURE <u>1.13% (6/55)</u>
TYPE <u>Ball M-193</u>	AIR SPACE <u>0.03c</u>
WEIGHT <u>55 Gr.</u>	RANGE <u>2</u>
REC'D _____	RECEIVER <u>FA</u>

SPECIFICATIONS: MIL-P-3984C, 1/5/65, incl. Amend. 3, 3/24/66, and Drawing 10535450, 4/29/66 and EO-S60251

	STORED		Fired After Additional Storage		DIFFERENCE											
					MEASURED				SPECIFICATION LIMITS							
	Hrs.	°F.	Hrs.	°F.	Barrel	Charge Grs.	Shots	Vel. ft./sec.	Cham. Press. 100 psi	Max. ind. Shot 100 psi	Vel. ft./sec.	Cham. Press. 100 psi	Vel. ft./sec.	Press. 100 psi	Individual Shot 100 psi	
Test	4 @ 160		6 @ 70±2		1280	26.3	10	3187					-40		-250	
Control	4 @ 70±2		6 @ 70±2		1280	26.3	10	3227								
Test	4 @ 160		6 @ 70±2		1286	26.3	10	472	503				-2		+50	620
Control	4 @ 70±2		6 @ 70±2		1286	26.3	10	474								
Test	4 @ 125		None		1280	26.3	10	3293					+66		-250	
Control	4 @ 70±2		None		1280	26.3	10	3227								
Test	4 @ 125		None		1286	26.3	10	502	527				+28		+50	620
Control	4 @ 70±2		None		1286	26.3	10	474								
Test	6 @ -65		None		1280	26.3	10	3043					-184		-250	
Control	6 @ 70±2		None		1280	26.3	10	3227								
Test	6 @ -65		None		1286	26.3	10	443	476				-31		+50	620
Control	6 @ 70±2		None		1286	26.3	10	474								
Test	72 @ -80		6 @ 70±2		1280	26.3	10	3174					-53		-250	
Control	72 @ 70±2		6 @ 70±2		1280	26.3	10	3227								
Test	72 @ -80		6 @ 70±2		1286	26.3	10	498	532				+24		+50	620
Control	72 @ 70±2		6 @ 70±2		1286	26.3	10	474								

THIS LOT OF POWDER MEETS THE SPECIFICATION REQUIREMENTS

- REMARKS: 1. Uncorrected figures used throughout.
2. All test cases waterproofed and crimped.

MANAGER E. O. RANDOLPH, JR.

PER Paul C. Tolman

U. S. GOVERNMENT PRINTING OFFICE: 1965

WASHINGTON, D. C. 20540

QUANTITY POINT NUMBER

TEMPERATURE TESTS—GOVERNMENT RIFLE POWDER

CASE
 MFR. TWIN CITIES
 PRIMER Factory
 REC'D _____
 BULLET
 MFR. TWIN CITIES
 TYPE Ball M-193
 WEIGHT 55 Gr.
 REC'D _____

LOT NO. 44635 (Du Pont 16)
 CALIBER 5.56MM M-193 Ball
 TYPE LMR-8208M
 DATE of Test 12/7/66 to 12/10/66
 G. D. 902
 MOISTURE 1.13% (6/55)
 AIR SPACE 0.03c
 RANGE 2
 RECEIVER FA

SPECIFICATIONS: MIL-P-3984C, 1/5/65, Incl. Amend. 3, 3/24/66, and Drawing 10535450, 4/29/66 and EO-S60251

	STORED		Fired After Additional Storage		DIFFERENCE										
	Bars	°F.	Bars	°F.	Barrel	Charge Gra.	Shots	Vel. ft./sec.	Port Press. 100 psi	Max. Ind. Shot 100 psi	Vel. ft./sec.	Port Press. 100 psi	Vel. ft./sec.	Port Press. 100 psi	Individual Shot 100 psi
Test	4 @	150	6 @	70±2											
Control	4 @	70±2	6 @	70±2											
Test	4 @	160	6 @	70±2	1286	26.3	10	147				+5		±20	
Control	4 @	70±2	6 @	70±2	1286	26.3	10	142							
Test	4 @	125	None												
Control	4 @	70±2	None												
Test	4 @	125	None		1286	26.3	10	146				+4		±20	
Control	4 @	70±2	None		1286	26.3	10	142							
Test	6 @	-65	None												
Control	6 @	70±2	None												
Test	6 @	-65	None		1286	26.3	10	142				0		±20	
Control	6 @	70±2	None		1286	26.3	10	142							
Test	72 @	-80	3 @	70±2											
Control	72 @	70±2	6 @	70±2											
Test	72 @	-80	6 @	70±2	1286	26.3	10	148				+6		±20	
Control	72 @	70±2	6 @	70±2	1286	26.3	10	142							

THIS LOT OF POWDER MEETS THE SPECIFICATION REQUIREMENTS

REMARKS:

1. Uncorrected figures used throughout.
2. All test cases waterproofed and crimped.

MANAGER E. O. RANDOLPH, JR.

PER Neil C. Miller

MR. Sikes

**E. I. DU PONT DE NEMOURS & CO. (INC.)
EXPLOSIVES DEPARTMENT - CARNEY'S POINT WORKS
SMOKELESS POWDER - CERTIFICATION OF TESTS**

Contract No.	DA-36-038-APC-4326/A/	Govt. Lot No.	44938	of 1967
Date Shipped	C 2/23/67	Powder Type	DU PONT IMR-8208M	
Weight Shipped, Lbs.		Du Pont Lot No.	30	
Du Pont Order No.	CD-7866	For	5.56MM Ball M-193	
Customer Order No.		Manufactured at	Carney's Point, N. J.	
Specification No.	MYL-P-3984C, 1/5/65	Date Packed	2/9/67	
Incl. Amend.	3, 3/24/66	Packed Weight, Lbs.	35,400	
Incl. Drawing	10535450, 4/29/66 and EO-S60251	Type Container	Fiber Paks at 100# each	

	Formula	Maximum	Minimum	Analysis
Nitrocellulose, %	100.0			93.83*
Diphenylamine (added), %	0.7	1.25	0.50	0.65*
Potassium Sulphate (added), %	1.0	1.00	0.10	0.79*
Dinitrotoluene (coated), %				
Ethylene Dimethacrylate (coated), %		8.0	2.0	4.38*
Graphite (glazed), %	0.15	0.4		0.35*
Tin, %				
Dibutylphthalate, %				
Potassium Nitrate, %				
Barium Nitrate, %				
Barium Carbonate, %				
Total Volatiles, %		2.35		1.21
Moisture, % (6/55)		1.25	0.75	1.11
Residual Solvent, %		1.10		0.10
Ash, %				0.08
Hygroscopicity, %		1.80		1.48
MVP Test at 134.5°C., Mins.			40'	100+
Explosion Test at 134.5°C., Hrs.			5	5+
Bulk Density		0.905	0.865	0.892
Dust & Foreign Matter, %		0.10		0.01
Form of Grain				Cylindrical
No. of Perforations				1
Dimensions: L	1/32	0.031	0.027	0.028
(Inches) D	0.041	0.029	0.025	0.025
d	0.010	0.006	0.004	0.004
Web		0.013	0.009	0.010
Grains/Lb.				1,139.698
Burning Surface/Lb. (sq. in.)				3.954

REMARKS:

*On volatiles-free basis.

CERTIFICATION

I certify that the material or product described in this report has been inspected and/or tested as stated herein, that such specimens or samples as have been inspected or tested were taken from the lot or quantity described herein, and that the results of these inspections and tests are as shown.

Manager: E. O. RANDOLPH, JR.

Date: 2/21/67

Typed: 2/21/67

BALLISTIC ACCEPTANCE TEST
FOR
SMALL ARMS PROPELLANT POWDERS

CARTRIDGE			BARRELS				POWDER			
REFERENCE	TEST LOT		VELOCITY	PRESSURE	PORT PRESSURE	Lot 30 (Govt 44938)				
Case	LC-Loaded	TC	Number	1302	1285	1285	Gal. 5.56M			
Primer	Ammunition	Factory	Piston	None	Short	Short	Type IMR-8208M			
Bullet	LC-Y-5.56-501	TC M 193	Length				Mfg. By DU PONT			
Bullet Wt.		55 Gr.	Head Space				Mfg. At CARNEYS PT.			
TEST EQUIPMENT			Times Fired				Weight 35,400#			
Chron	Counter		Receiver	FA	FA	FA	Packed 2/9/67			
Target	Lumiline		Fir. Pin Pro.				G.D. 892			
Range Temp., °F			Fir. Pin Ind.				Moist 1.11%(6/55)			
REFERENCE POWDER FIRINGS, LOT LC-Y-5.56-501										
				VELOCITY AT 15 FT.			PRESSURE, psi			
	SBL.	CHG.	AS	RDS.	MEAN	EV	SD	MEAN	SD	MAX.
Velocity Firing										
Assessment					3248					
2/10/67 Today's Firing	1302			20	3233					
Correction					+ 15					
Chamber Pressure Firing										
Assessment								46100		
2/13/67 Today's Firing	1285			20				44700		
Correction								+1400		
Port Pressure Firing										
Assessment								14700		
2/13/67 Today's Firing	1285			20				15900		
Correction								-1200		
TEST RESULTS, IMR-8208M, Govt. Lot No. 44938, DuPont Lot No. 30										
Velocity Firing										
2/10/67	1302	25.8	0.01d	20	3230		15.8			
Velocity Correction					+ 15					
Corrected Velocity					3245					
Spec. Req.					3250	±50	26.0	(Max.)		
Chamber Pressure Firing										
2/10/67	1285	25.8	0.01d	20				43400		
Chamber Pressure Correction								+1400		
Corrected Chamber Pressure								44800		
Specification Requirement (Max.)								50,000		
Port Pressure Firing										
2/10/67	1285	25.8	0.01d	20				15500		
Action Times - Milliseconds										
Average	1.00									
Max. Ind.										
S.D.										
S.D. × 4										
Ave. ± 4SD										
Spec. Limit (Max.)	2.5									
Pressure, psi										
Average										
S.D.										
S.D. × 3										
Ave. ± 3SD										
Spec. Limit										
THIS LOT OF POWDER DOES MEET THE REQUIREMENTS OF SPEC.										
MIL-E-3984C, 1/5/65, Incl. Amend. 3, 3/24/66,										
Drawing 10535450, 4/29/66 and EO-S60251										
All test cases waterproofed and crimped.										
E. I. du Pont de Nemours & Co. (Inc.)										
Carneys Point Works										
Manager E. O. RANDOLPH, JR.										
By <i>H. J. Miller</i>										
Date: 2/21/67										

E. I. DUPONT DE NEMOURS & COMPANY (INC.)

ROCKFORD DIVISION

GARREYS POINT WORKS

TEMPERATURE TESTS - GOVERNMENT RIFLE POWDER

CASE		LOT NO.	Govt. Lot 44938 (DuPont Lot 30)
MFR.	TC	CALIBER	5.56MM Ball M-193
PRIMER		TYPE	IMR-8208M
REC'D		DATE OF	Test 2/13 to 2/16/67
BULLET		G. D.	892
MFR.	Twin Cities	MOISTURE	(6/55) 1.11%
TYPE	Ball M-193	AIR SPACE	0.01" c
WEIGHT	55 gr.	RANGE	2
REC'D		RECEIVER	FA

SPECIFICATIONS: MIL-P-3984C, 1/5/65 Incl. Amend. 3, 3/24/66, Drawing 10535450, 4/29/66 and EO-S60251

	STORED		Fired After Additional Storage		DIFFERENCE											
					MEASURED					SPECIFICATION LIMITS						
	Hrs.	°F.	Hrs.	°F.	Barrel	Charge Grs.	Shots	Vel. ft./sec.	Cham. Pres. 100 psi	Max. Ind. Shot 100 psi	Vel. ft./sec.	Cham. Pres. 100 psi	Vel. ft./sec.	Cham. Pres. 100 psi	Individual Shot 100 psi	
Test	4 @ 160		6 @ 70 → 2		1302	25.8	10	3238					-5		-250	
Control	4 @ 70 → 2		6 @ 70 → 2		1302	25.8	10	3243								
Test	4 @ 160		8 @ 70 → 2		1285	25.8	10		438	454			+1		+50	620
Control	4 @ 70 → 2		6 @ 70 → 2		1285	25.8	10		437							
Test	4 @ 125		None		1302	25.8	10	3291					+48		-250	
Control	4 @ 70 → 2		None		1302	25.8	10	3243								
Test	4 @ 125		None		1285	25.8	10		466	464			+9		+50	620
Control	4 @ 70 → 2		None		1285	25.8	10		437							
Test	6 @ -65		None		1302	25.8	10	3007					-206		-250	
Control	6 @ 70 → 2		None		1302	25.8	10	3243								
Test	6 @ -65		None		1285	25.8	10		369	416			-48		+50	620
Control	6 @ 70 → 2		None		1285	25.8	10		437							
Test	72 @ -60		6 @ 70 → 2		1302	25.8	10	3256					-7		-250	
Control	72 @ 70 → 2		6 @ 70 → 2		1302	25.8	10	3243								
Test	72 @ -60		6 @ 70 → 2		1285	25.8	10		427	450			-10		+50	620
Control	72 @ 70 → 2		6 @ 70 → 2		1285	25.8	10		437							

THIS LOT OF POWDER MEETS THE SPECIFICATION REQUIREMENTS

- REMARKS:
1. All test cases waterproofed and crimped.
 2. Uncorrected figures used throughout.

MANAGER E. O. RANDOLPH, JR.

PER

Neil C. Miller

REC'D

**E. I. DU PONT DE NEMOURS & COMPANY (INC.)
EXPLOSIVES DEPARTMENT
CARNEYS POINT WORKS**

TEMPERATURE TESTS—GOVERNMENT RIFLE POWDER

CASE		LOT NO.	<u>Govt. 44938 (DuPont Lot 30)</u>
MFR.	<u>TC</u>	CALIBER	<u>5.56MM Ball M-193</u>
PRIMER		TYPE	<u>IMR-8208M</u>
REC'D		DATE	<u>of Test 2/13/67 to 2/16/67</u>
BULLET		G. D.	<u>892</u>
MFR.	<u>TC</u>	MOISTURE	<u>(6/55) 1.11%</u>
TYPE	<u>Ball M-193</u>	AIR SPACE	<u>0.01" c</u>
WEIGHT	<u>55 Gr.</u>	RANGE	<u>2</u>
REC'D		RECEIVER	<u>FA</u>

SPECIFICATIONS: MIL-P-3984C, 1/5/65 Incl. Amend. 3, 3/24/66, Drawing 10535450, 4/29/66 and EO-S60251

	STORED		Fired After Additional Storage		DIFFERENCE												
					MEASURED					SPECIFICATION LIMITS							
					Hrs.	°F.	Barrel	Charge Wts.	Shots	Vel. ft./sec.	Port. Press. 100 psi	Max. Ind. Shot 100 psi	Vel. ft./sec.	Port. Press. 100 psi	Individual Shot 100 psi		
Test	4 @ 160		6 @ 70 → 2														
Control	4 @ 70 → 2		6 @ 70 → 2														
Test	4 @ 160		6 @ 70 → 2	1285	25.8	10		155					0				
Control	4 @ 70 → 2		6 @ 70 → 2	1285	25.8	10		155									
Test	4 @ 125		None														
Control	4 @ 70 → 2		None														
Test	4 @ 125		None	1285	25.8	10		155					0				
Control	4 @ 70 → 2		None	1285	25.8	10		155									
Test	6 @ -- 65		None														
Control	6 @ 70 → 2		None														
Test	6 @ -- 65		None	1285	25.8	10		150					-5				
Control	6 @ 70 → 2		None	1285	25.8	10		155									
Test	72 @ -- 80		6 @ 70 → 2														
Control	72 @ 70 → 2		6 @ 70 → 2														
Test	72 @ -- 80		6 @ 70 → 2	1285	25.8	10		156					+1				
Control	72 @ 70 → 2		6 @ 70 → 2	1285	25.8	10		155									

THIS LOT OF POWDER MEETS THE SPECIFICATION REQUIREMENTS

- REMARKS: 1. All test cases waterproofed and crimped.
2. Uncorrected figures used throughout.

MANAGER E. O. RANDOLPH, JR.

E. I. DU PONT DE NEMOURS & CO. (INC.)
EXPLOSIVES DEPARTMENT--CARNEYS POINT WORKS
SMOKELESS POWDER--CERTIFICATION OF TESTS

Contract No.	DA-36-038-AMC-4326/A/	Govt. Lot No.	44939	of 1967
Date Shipped	c 2/23/67	Powder Type	DU PONT IMR-8208M	
Weight Shipped, lbs.		Du Pont Lot No.	31	
Du Pont Order No.	CD-7866	For	5.56MM Ball M-193	
Customer Order No.		Manufactured at	Carney's Point, N. J.	
Specification No.	MIL-P-3984C, 1/5/65	Date Packed	2/10/66	
Incl. Amend.	3, 3/24/66	Packed Weight, lbs.	35,700	
Incl. Drawing	10535450, 4/29/66 and EO-S60251	Type Container	Fiber Paks at 100# each	

	Formula	Maximum	Minimum	Analysis
Nitrocellulose, %	100.0			93.80*
Diphenylamine (added), %	0.7	1.25	0.50	0.65*
Potassium Sulphate (added), %	1.0	1.00	0.10	0.79*
Dinitrotoluene (coated), %				
Ethylene Dimethacrylate (coated), %		3.0	2.0	4.47*
Graphite (glazed), %	0.15	0.4		0.29*
Tin, %				
Dibutylphthalate, %				
Potassium Nitrate, %				
Barium Nitrate, %				
Barium Carbonate, %				
Total Volatiles, %		2.35		1.20
Moisture, %		1.25	0.75	1.08
Residual Solvent, %		1.10		0.12
Ash, %				0.08
Hygroscopicity, %		1.80		1.52
MVP Test at 134.5°C., Mins.			40'	100+
Explosion Test at 134.5°C., Mins.			5	5+
Bulk Density		0.905	0.865	0.890
Dirt & Foreign Matter, %		0.10		0.01
Form of Grain				Cylindrical
No. of Perforations				1
Dimensions: L	1/32	0.031	0.027	0.028
(Inches) D	0.041	0.029	0.025	0.025
d	0.010	0.006	0.004	0.004
Web		0.013	0.009	0.010
Grains/lb.				1,175,129
Burning Surface/lb. (sq. in.)				4.063

REMARKS:

*On volatiles-free basis.

CERTIFICATION

I certify that the material or product described in this report has been inspected and/or tested as stated herein, that such specimens or samples as have been inspected or tested were taken from the lot or quantity described herein, and that the results of these inspections and tests are as shown.

Inspector: E. O. SANDOLEW, JR.

By: *Wesley C. Miller*

Date: 2/21/67

F. I. INC. 2100 EAST 10TH AVE. (B-21)
 EXPLOSIVES DEPARTMENT--CARNEY'S POINT WORKS

SMOKELESS POWDER--DESCRIPTION SHEET--U. S. GOVERNMENT

Date Sampled	2/10/67	Cart. Lot No.	44939	of 1967
Date Test Finished		Powder Type	DU PONT IMR-8208M	
Date Desc. Shts. Forwarded		Du Pont Lot No.	31	
Du Pont Order No.	CD-7866	For	5.56MM Ball M-193	
Customer Order No.		Manufactured at	Carney's Point, N. J.	
Specification No.	MIL-P-3984C, 1/5/65	Date Packed	2/10/67	
Incl. Amend.	3, 3/24/66	Packed Weight, Lbs.	35.700	
Incl. Drawing	10535450, 4/29/66 and EC-S60251	Type Container	Fiber Paks at 100# each	
		Contract No.	DA-36-038-AMC-4326/A/	

NITROCELLULOSE BLENDS
 2221, 2223, 2225, 2227, 2228

CHEMICAL AND PHYSICAL TESTS	
	Formula Analysis
Nitrocellulose, %	100.0 93.80*
Diphenylamino (added), %	0.7 0.65*
Potassium Sulphate (added), %	1.0 0.79*
Dibutyl Sebacate (added), %	
Ethylene Dimethacrylate (added), %	4.82 4.47*
Graphite (glazed), %	0.15 0.29*
Iron, %	
Dibutyl Sebacate, %	
Potassium Nitrate, %	
Barium Nitrate, %	
Sodium Carbonate, %	

NITROCELLULOSE ANALYSIS			
	Max.	Min.	Ave.
Nitrogen, %	13.19	13.11	13.16
KI-Starch Test, Mins.	45+	36	40
MVP Test at 134.5°C., Mins.	30	30	30

SOLVENT	
Lbs. per 100 lb. dry NC	92
Consisting of, per 100 lbs. of Solvent:	
Lbs. Ethyl Ether	65
Lbs. Ethyl Alcohol	35

PROCESS	TIME		TEMP., °C.	
	Days	Hours	From	To
Bolled in Still				
Solvent Recovery		20	35	55
Water Drying, Before Coating	5			60
Water Drying, After Coating				
Air Drying		12-14		55

Total Volatiles, %	1.20
Moisture, % (6/55)	1.08
Residual Solvent, %	0.12
Ash, %	0.08
Hygroscopicity, %	1.52
MVP Test at 134.5°C., Mins.	100+
Explosion Test at 134.5°C., Mins.	5+
Grain Density	890
Dust & Foreign Matter, %	0.01
Form of Grain	Cylindrical
No. of Perforations	1
Dimensions: L	1/32 0.028
D	0.041 0.025
d	0.010 0.004
Web	0.010
Grain/In.	1.175.129
Barrel Surface/lb. (sq. in.)	4.063

*On volatiles-free basis.

APPROVED: E. O. RANDOLPH, JR.
 For: *[Signature]*
 Date: 2/21/67
 Type: *[Signature]*

**BALLISTIC ACCEPTANCE TEST
FOR
SMALL ARMS PROPELLANT POWDERS**

CARTRIDGE			BARRELS			POWDER				
REFERENCE	TEST LOT		VELOCITY	PRESSURE	PORT PRESSURE	Lot 31 (Govt. 44939)				
Case	IC-Loaded	TC	Number	1302	1285	1285	Cal. 5.56MM			
Primer	Ammunition	Factory	Piston	None	Short	Short	Type IMR-8208M			
Bullet	IC-Y-5.56-50	TC M193	Length				Mfg. By DU PONT			
Bullet Wt.		55 Gr.	Head Space				Mfg. At CARNEYS PT.			
TEST EQUIPMENT			Times Fired				Weight 35.700#			
Chron	Counter		Receiver	FA	FA	FA	Packed 2/10/67			
Target	Lumline		Fir. Pin Pro.				G.D. 890			
Range Temp., °F			Fir. Pin Ind.				Moist 1.08%(6/55)			
REFERENCE POWDER FIRINGS, LOT IC-Y-5.56-501										
			VELOCITY AT 15 FT.			PRESSURE, psi				
	SBL.	CHG.	AS	RDS.	MEAN	EV	SD	MEAN	SD	MAX.
Velocity Firing										
Assessment					3248					
2/10/67 Today's Firing	1302			20	3233					
Correction					+ 15					
Chamber Pressure Firing										
Assessment								46100		
2/13/67 Today's Firing	1285			20				44700		
Correction								+1400		
Port Pressure Firing										
Assessment								14700		
2/13/67 Today's Firing	1285			20				15900		
Correction								-1200		
TEST RESULTS, IMR-8208M, Govt. Lot No. 44939, DuPont Lot No. 31										
Velocity Firing										
2/10/67	1302	25.9	0.0	20	3215		15.1			
Velocity Correction					+ 15					
Corrected Velocity					3230					
Spec. Req.					3250	±20	26.0	(Max.)		
Chamber Pressure Firing										
2/10/67	1285	25.9	0.0	20				42500		
Chamber Pressure Correction								+1400		
Corrected Chamber Pressure								43900		
Specification Requirement (Max.)								50000		
Port Pressure Firing										
2/10/67	1285	25.9	0.0	20				15700		
Action Time, Milliseconds										
Average	1.01									
Max. Ind.										
S.D.										
S.D. × 4										
Ave. + 4SD										
Spec. Limit (Max.)	2.5									
Pressure, psi										
Average										
S.D.										
S.D. × 3										
Ave. + 3SD										
Spec. Limit										

THIS LOT OF POWDER **DOES** MEET THE REQUIREMENTS OF SPEC.
 MLL-P-3246, 1/5/65, Incl. Amend. 3, 3/24/66,
 Drawing 10535450, 4/29/66 and EO-S60251

All test cases waterproofed and crimped.
 E. I. du Pont de Nemours & Co. (Inc.)
 Carneys Point Works
 Manager E. O. RANDOLPH, JR.
 By *H. C. Miller*
 Date: 2/21/67

E. I. DUPONT DE NEMOURS & COMPANY (INC.)

EXPLOSIVES DEPARTMENT

CARNEYS POINT WORKS

TEMPERATURE TESTS - GOVERNMENT RIFLE POWDER

CASE		LOT NO.	Govt. 44939 (DuPont Lot 31)
MFR.	TC	CALIBER	5.56MM Ball M-193
PRIMER		TYPE	IMR-8208M
REC'D		DATE of Test	2/13/67 to 2/16/67
BULLET		G. D.	890
MFR.	TC	MOISTURE	(6/55) 1.08%
TYPE	Ball M-193	AIR SPACE	0.00"
WEIGHT	55 Gr.	RANGE	2
REC'D		RECEIVER	FA

SPECIFICATIONS: MTI-P-3984C, 1/5/65 Incl. Amend. 3, 3/24/66, Drawing 10535450, 4/29/66 and EO-S60251

	STORED		Fired After Additional Storage		DIFFERENCE										
	Hrs.	°F.	Hrs.	°F.	Barrel	Charge Grs.	Shots	Vel. ft./sec.	Cham. Press. 100 psi	Max. Fad. Shot 100 psi	Vel. ft./sec.	Cham. Press. 100 psi	Vel. ft./sec.	Cham. Press. 100 psi	Individual Shot 100 psi
Test	4 @	160	6 @	70+2	1302	25.9	10	3219			+5		-250		
Control	4 @	70+2	6 @	70+2	1302	25.9	10	3214							
Test	4 @	160	6 @	70+2	1285	25.8	10		425	439	-5		+50	620	
Control	4 @	70+2	6 @	70+2	1285	25.8	10		430						
Test	4 @	125	None		1302	25.8	10	3208			+54		-250		
Control	4 @	70+2	None		1302	25.8	10	3214							
Test	4 @	125	None		1285	25.8	10		439	460	+9		+50	620	
Control	4 @	70+2	None		1285	25.8	10		430						
Test	6 @	-65	None		1302	25.8	10	3053			-161		-250		
Control	6 @	70+2	None		1302	25.8	10	3214							
Test	6 @	-65	None		1285	25.8	10		387	404	-43		+50	620	
Control	6 @	70+2	None		1285	25.8	10		430						
Test	72 @	-80	6 @	70+2	1302	25.8	10	3193			-21		-250		
Control	72 @	70+2	6 @	70+2	1302	25.8	10	3214							
Test	72 @	-80	6 @	70+2	1285	25.8	10		420	446	-10		+50	620	
Control	72 @	70+2	6 @	70+2	1285	25.8	10		430						

THIS LOT OF POWDER MEETS THE SPECIFICATION REQUIREMENTS

REMARKS:

1. All test cases waterproofed and crimped.
2. Uncorrected figures used throughout.

MANAGER E. O. RANDOLPH, JR.

PER *Neil C. Miller*

E. I. DU PONT DE NEMOURS & COMPANY (INC.)
EXPLOSIVES DEPARTMENT
CARNEYS POINT WORKS

TEMPERATURE TESTS--GOVERNMENT RIFLE POWDER

CASE		LOT NO.	<u>Govt. 44939 (DuPont Lot 31)</u>
MFR.	<u>TC</u>	CALIBER	<u>5.56MM M-193 Ball</u>
PRIMER		TYPE	<u>IMR-8208M</u>
REC'D		DATE	<u>of Test 2/13/67 to 2/16/67</u>
BULLET		G. D.	<u>890</u>
MFR.	<u>TC</u>	MOISTURE	<u>(6/55) 1.08%</u>
TYPE	<u>Ball M-193</u>	AIR SPACE	<u>0.00"</u>
WEIGHT	<u>55 Gr.</u>	RANGE	<u>2</u>
REC'D		RECEIVER	<u>EA</u>

SPECIFICATIONS: MIL-P-3984C, 1/5/65 Incl. Amend. 3, 3/24/66, Drawing 10535450, and EO-S60251

	STORED		Fired After Additional Storage		DIFFERENCE										
					MEASURED					SPECIFICATION LIMITS					
	Hrs.	°F.	Hrs.	°F.	Correl	Charge Grs.	Shots	Vel. ft./sec.	Port Press. 100 psi	Max. Ind. Shot 100 psi	Vel. ft./sec.	Port Press. 100 psi	Vel. ft./sec.	Port Press. 100 psi	Individual Shot 100 psi
Test	4 @ 160		6 @ 70±2												
Control	4 @ 70±2		6 @ 70±2												
Test	4 @ 150		6 @ 70±2		1285	25.9	10		153			-1		±20	
Control	4 @ 70±2		6 @ 70±2		1285	25.9	10		154						
Test	4 @ 125		None												
Control	4 @ 70±2		None												
Test	4 @ 125		None		1285	25.9	10		155			+1		±20	
Control	4 @ 70±2		None		1285	25.9	10		154						
Test	6 @ -65		None												
Control	6 @ 70±2		None												
Test	6 @ -65		None		1285	25.9	10		148			-6		±20	
Control	6 @ 70±2		None		1285	25.9	10		154						
Test	72 @ -80		6 @ 70±2												
Control	72 @ 70±2		6 @ 70±2												
Test	72 @ -80		6 @ 70±2		1285	25.9	10		154			0		±20	
Control	72 @ 70±2		6 @ 70±2		1285	25.9	10		154						

THIS LOT OF POWDER MEETS THE SPECIFICATION REQUIREMENTS

- REMARKS:
1. All test cases waterproofed and crimped.
 2. Uncorrected figures used throughout.

Handwritten initials

MANAGER E. C. RANDOLPH, JR.

PER *Handwritten signature*

APPENDIX D

FLOW MEASUREMENT INSTRUMENT READINGS AND GAS TUBE WEIGHTS

Thousand of Rounds Fired on Endurance Test

Rifle Number	Ctg. Lot	Flow Measurement Instrument Reading										
		0	1	2	3	4	5	6	7	8	9	10
843489 (1)	RA5244	1.41	1.42	1.48	1.51	1.45	1.52	1.50	1.48	1.47	1.49	1.47
848305 (2)	RA5244	1.50	1.52	1.53	1.51	1.54	1.62	1.62	1.61	1.60	1.60	1.60
850464 (3)	RA5244	1.60	1.45	1.47	1.48	1.49	1.46	1.46	1.48	1.45	1.48	1.50
855603 (4)	TW18179	1.50	1.50	1.47	1.50	1.46	1.46	1.49	1.49	1.50	1.49	1.52
856133 (5)	TW18179	1.48	1.47	1.43	1.40	1.40	1.45	1.43	1.49	1.36	1.44	1.42
856760 (6)	TW18179	1.43	1.50	1.46	1.47	1.45	1.44	1.47	1.46	1.47	1.47	1.50
859129 (7)	RA5320	1.40	1.41	1.50	1.66	1.79	2.35 ^a	1.41	1.60	1.73	1.89	1.33 ^b
859908 (8)	RA5320	1.45	1.51	1.55	1.69	1.77	1.95	2.23	1.39 ^c	1.56	1.64	1.88
861015 (9)	RA5320	1.40	1.50	1.69	1.76	2.01	2.43 ^d	1.36	1.59	1.52	1.50	1.50 ^f
862235 (10)	TW18191	1.45	1.33	1.67	1.73	1.63	2.00	1.58	1.70	1.62	1.63	1.62
863323 (11)	TW18191	1.45	1.75	1.60	1.77	1.67	1.72	1.69	1.72	1.64	1.73	1.66
863632 (12)	TW18191	1.45	1.61	1.75	1.66	1.60	1.59	1.60	1.61	1.60	1.65	1.63
863749 (13)	RA5244	1.51e										

		Gas Tube Weight (Grams)										
843489 (1)	RA5244	27.1996	27.3459	27.4350	27.4512	27.5072	27.5510	27.5760	27.5094	27.5242	27.5312	27.5524
848305 (2)	RA5244	28.1866	28.3636	28.4354	28.4786	28.5390	28.5672	28.6134	28.6124	28.6682	28.6194	28.6756
850464 (3)	RA5244	28.2252	27.7608	27.8310	27.8496	27.8966	27.8980	27.9326	27.9464	27.8588	27.8818	27.9408
855603 (4)	TW18179	27.9947	28.1005	28.0810	28.0862	28.0114	28.0832	28.1200	28.0982	28.1001	28.0096	28.0382
856133 (5)	TW18179	27.6019	27.6940	27.7064	27.6662	27.6162	27.5590	27.7000	27.7944	27.5910	27.6384	27.6350
856760 (6)	TW18179	27.5378	28.2716	28.2428	28.2276	28.1968	28.2256	28.2472	28.1796	28.1098	28.1882	28.2346
859129 (7)	RA5320	27.2443	27.3812	27.4672	27.5710	27.6850	27.9720 ^a	27.6126	27.7812	27.9234	28.0382	26.4446 ^b
859908 (8)	RA5320	27.7448	27.9432	28.0368	28.1088	28.1902	28.3142	28.5272	27.4240 ^c	27.6296	27.7490	28.0218
861015 (9)	RA5320	27.3500	27.5280	27.6566	27.7708	28.0078	28.2728 ^d	26.7294	26.8884	26.9946	27.0408	27.0356 ^f
862235 (10)	TW18191	27.5514	28.2535	28.0774	27.9990	27.9492	28.0320	27.9200	28.0080	27.7980	27.8750	27.7960
863323 (11)	TW18191	28.5125	29.0332	28.8362	29.0090	28.8656	28.9260	28.8326	28.9072	28.8348	28.8468	28.8078
863632 (12)	TW18191	27.7184	28.0204	28.1714	28.1540	28.1000	28.0880	28.0742	28.0518	28.0404	28.0218	28.1280
863749 (13)	RA5244	26.4473										

^a The gas tube was replaced. Air flow measurement was 1.39 and weight was 27.4740g for the new tube.

^b The gas tube was replaced after 9500 rounds on the function test. Air flow reading was 2.23 and weight was 28.1864g for the old tube. The air flow reading was 1.33 and the weight was 26.4416g for the new tube.

^c The gas tube was replaced after firing 6500 rounds on the function test. Air flow reading was 2.77 and weight was 28.7386g for the old tube. The air flow reading was 1.41 and weight was 27.3068g for the new tube.

^d The gas tube was replaced after 5000 rounds on the function test. Air flow reading was 1.34 and weight was 26.6188g for the new tube.

^e 1.37 after firing 1 shot.

^f Test was discontinued after 9200 rounds on Function Test.

APPENDIX E
X-RAY PHOTOGRAPHS OF GAS TUBES

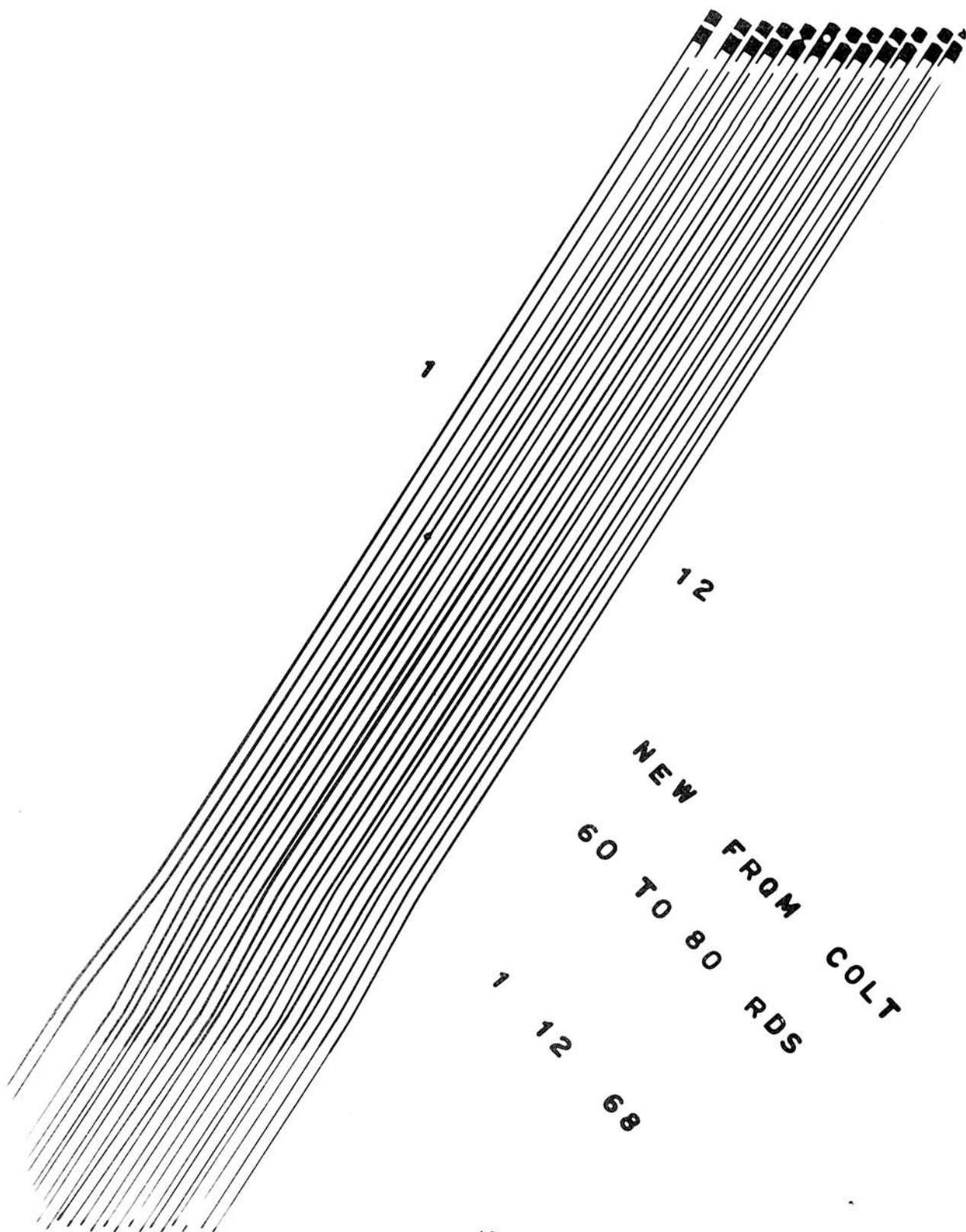

2-2-68

Gas Tubes After Firing 2000 Rounds
on Function Test

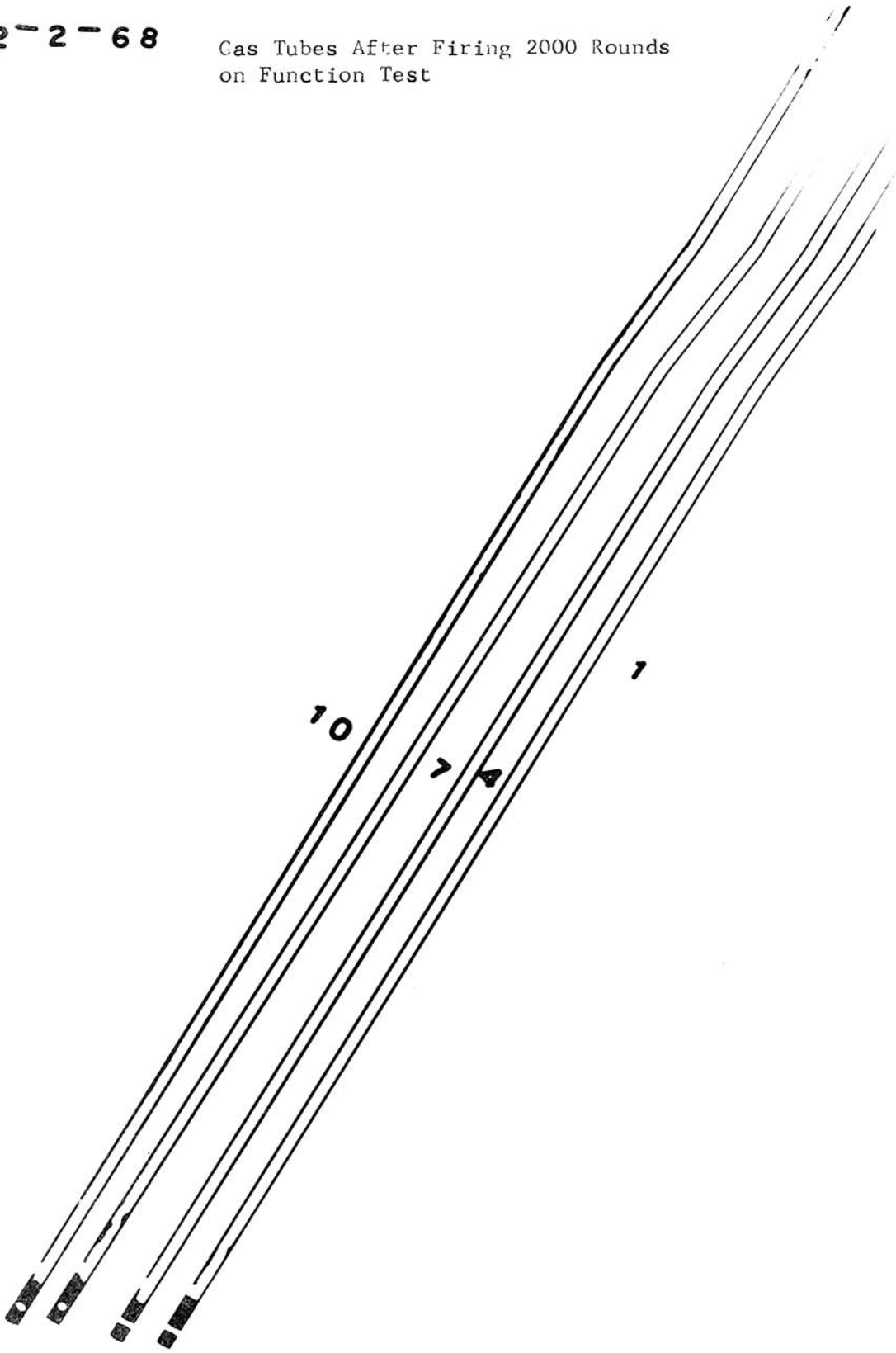

Gas Tubes After Firing 4000 Rounds
on Function Test

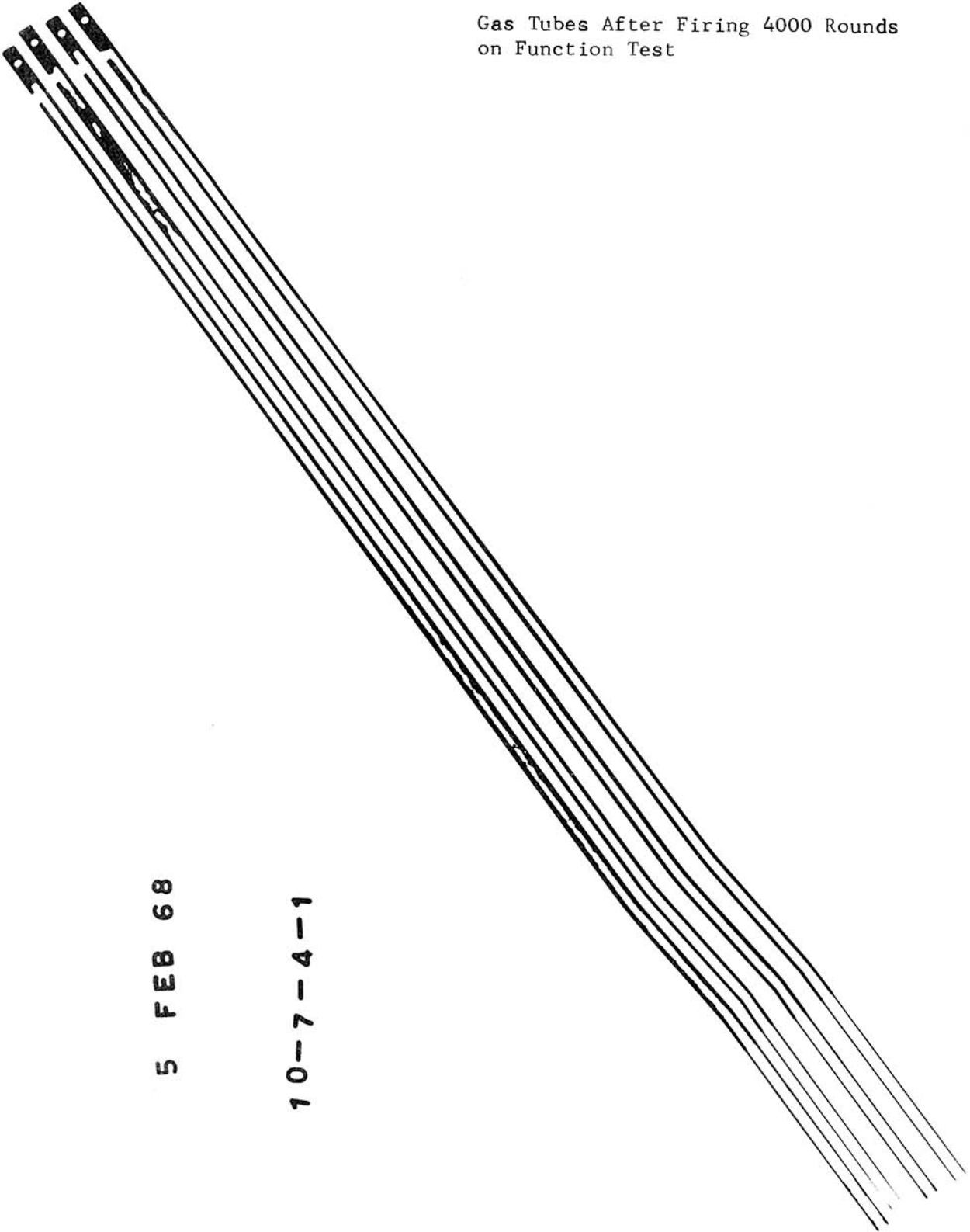

5 FEB 68

10-7-4-1

Gas Tubes After Firing 5000 Rounds
on Function Test Tubes are (left to
right) 10, 7, 7A (new), 4 and 1.

6 FEB 68

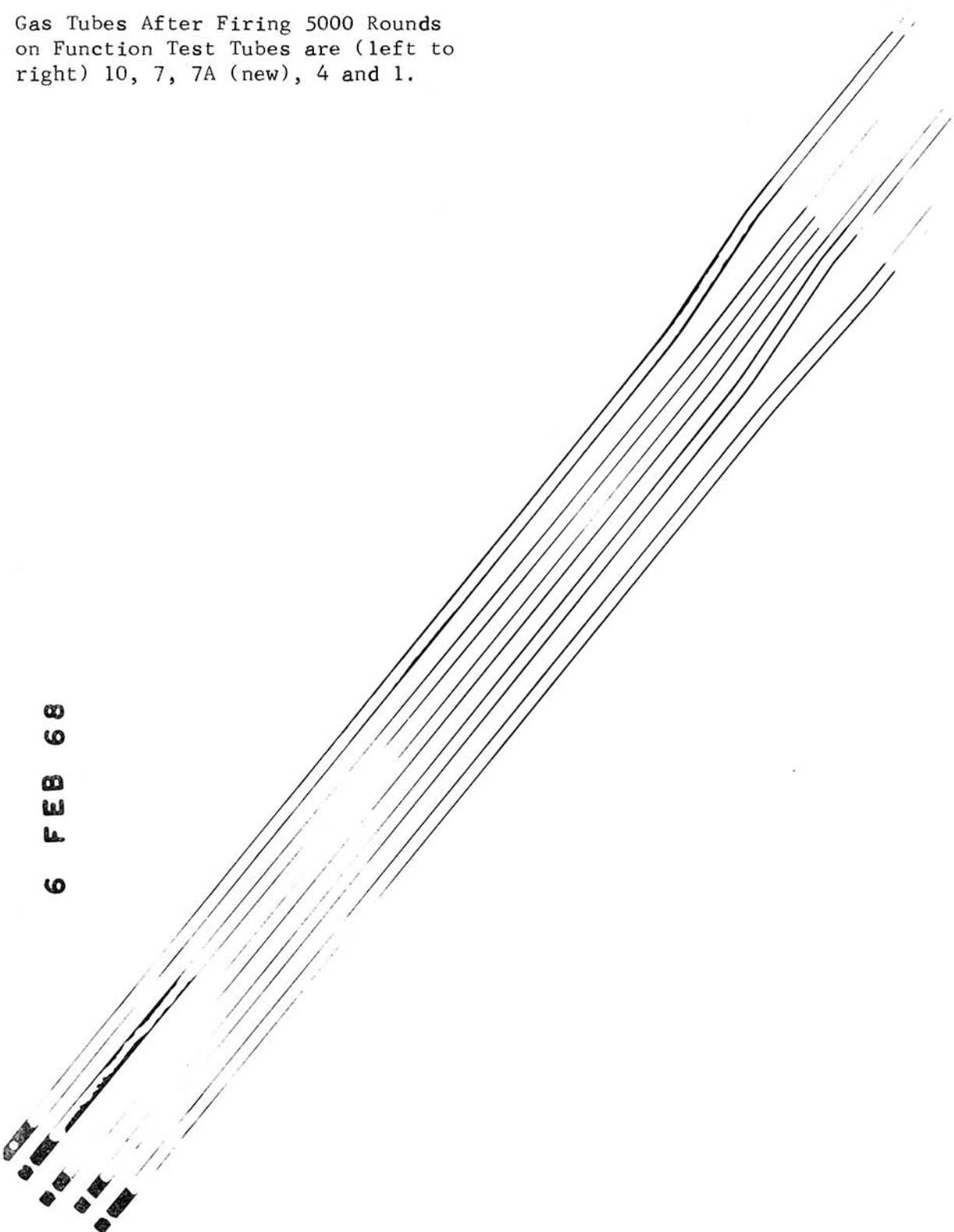

Gas Tubes After Firing 6000 Rounds
on Function Test.
Tube 7A was used in firing 1000 rounds
on the Function Test.

7 FEB 68

10-7A-4-1

Gas Tubes after Firing 8000 rounds on function test.
Tube 7A was used in firing 3000 rounds on the function
test.

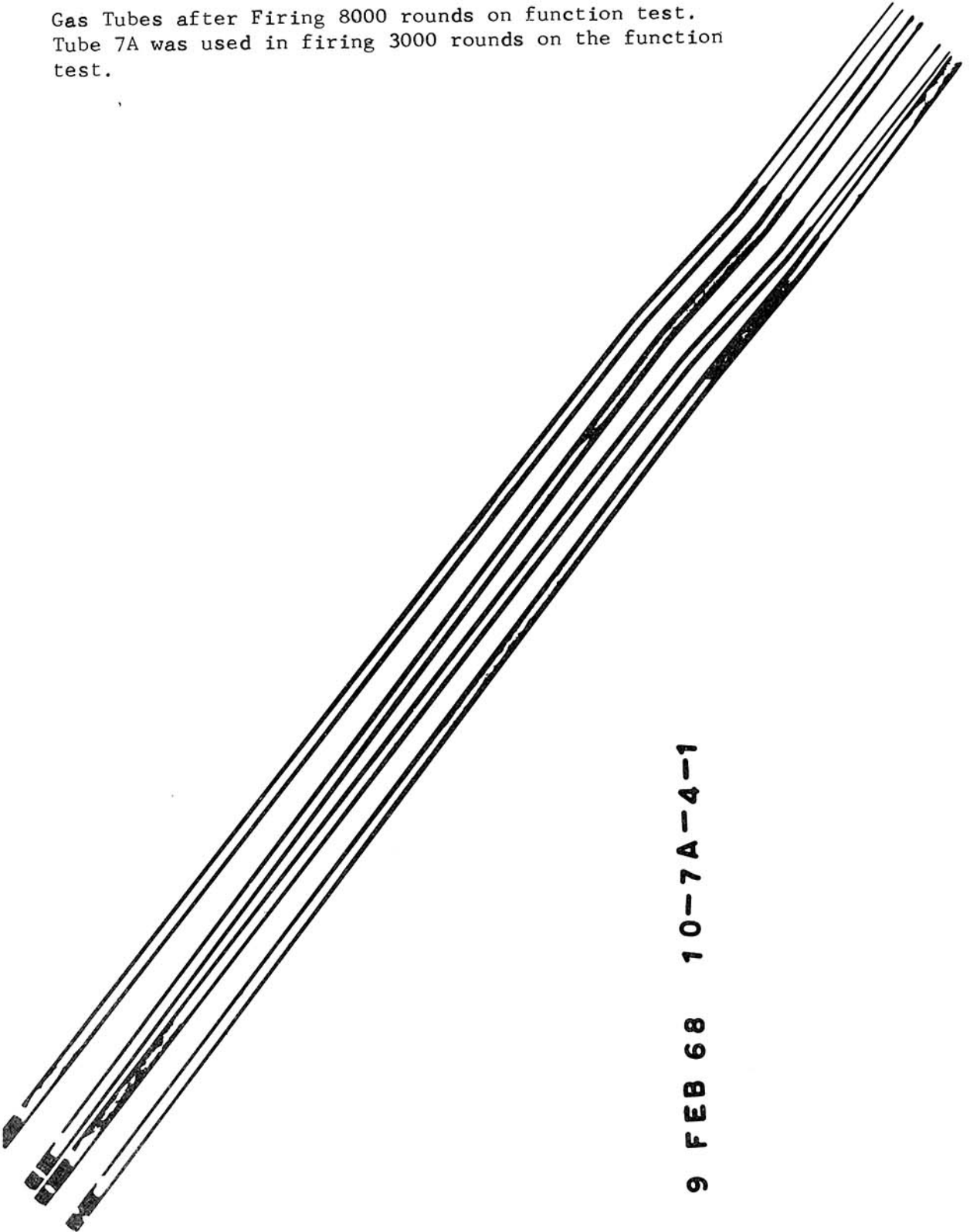

9 FEB 68 10-7A-4-1

Gas tubes after firing 10,000 rounds on function test. Tubes are (left to right) 10, 7B, 7A 4 and 1. Gas tube 7A was used in firing 4,500 rounds on the function test and tube 7B was used in firing 500 rounds.

12 FEB 68

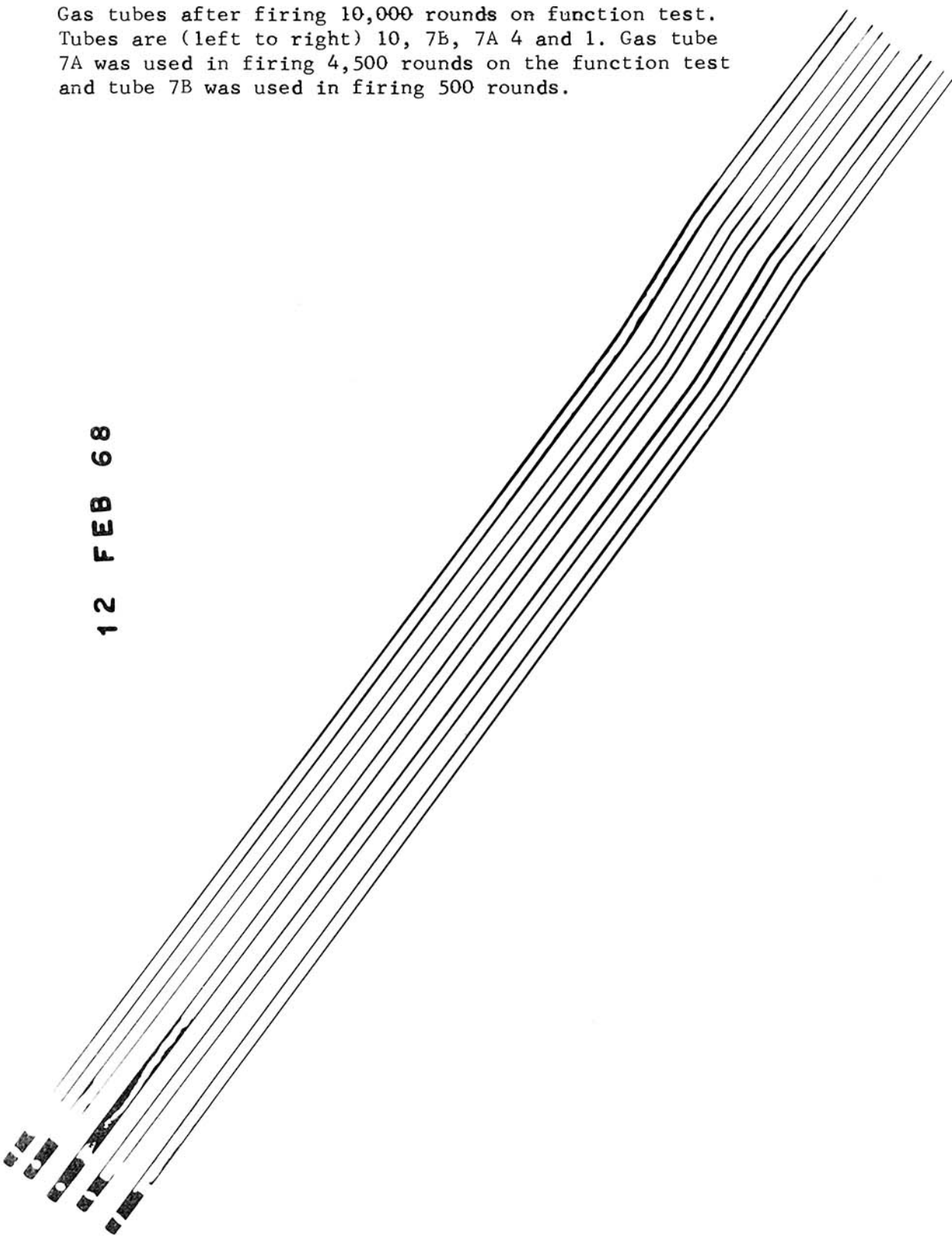

Gas Tubes after firing 2000 rounds on function test.
Tubes are (left to right) 2, 5, 8 and 11.

14 FEB 68

2-5-8-11

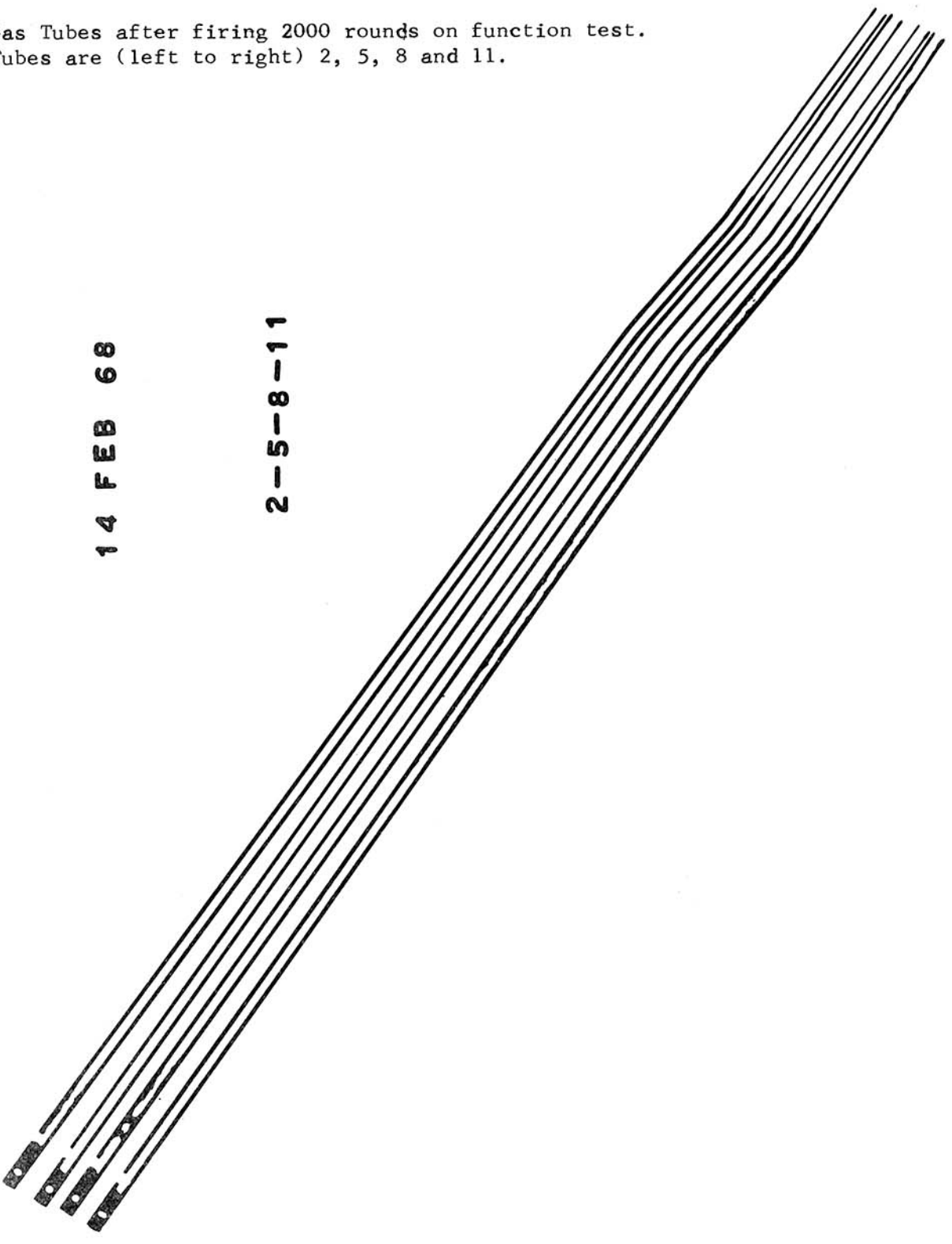

Gas Tubes after firing
4000 rounds on function test.

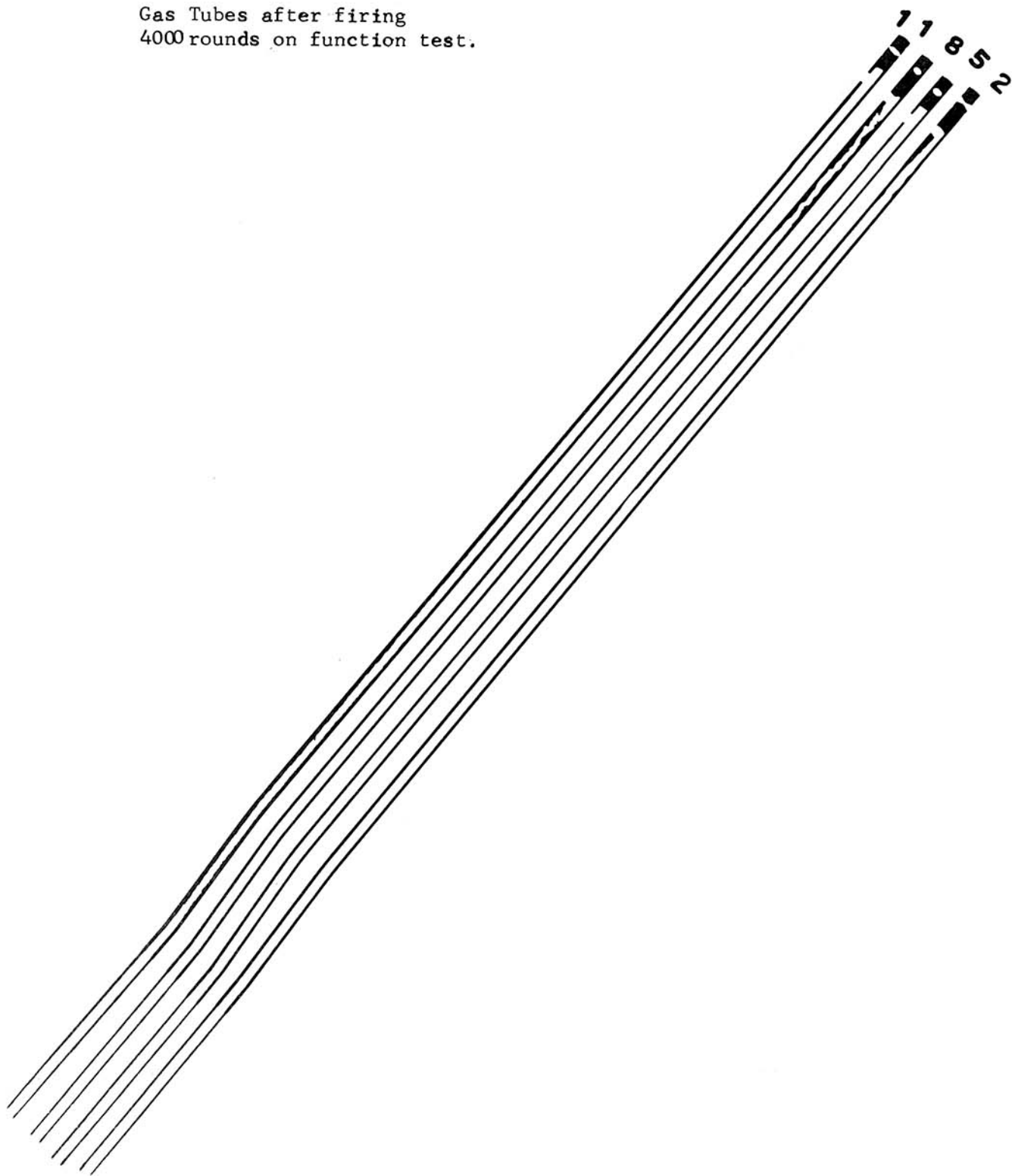

Gas tubes after firing 6000 rounds on function test.

19 FEB 68

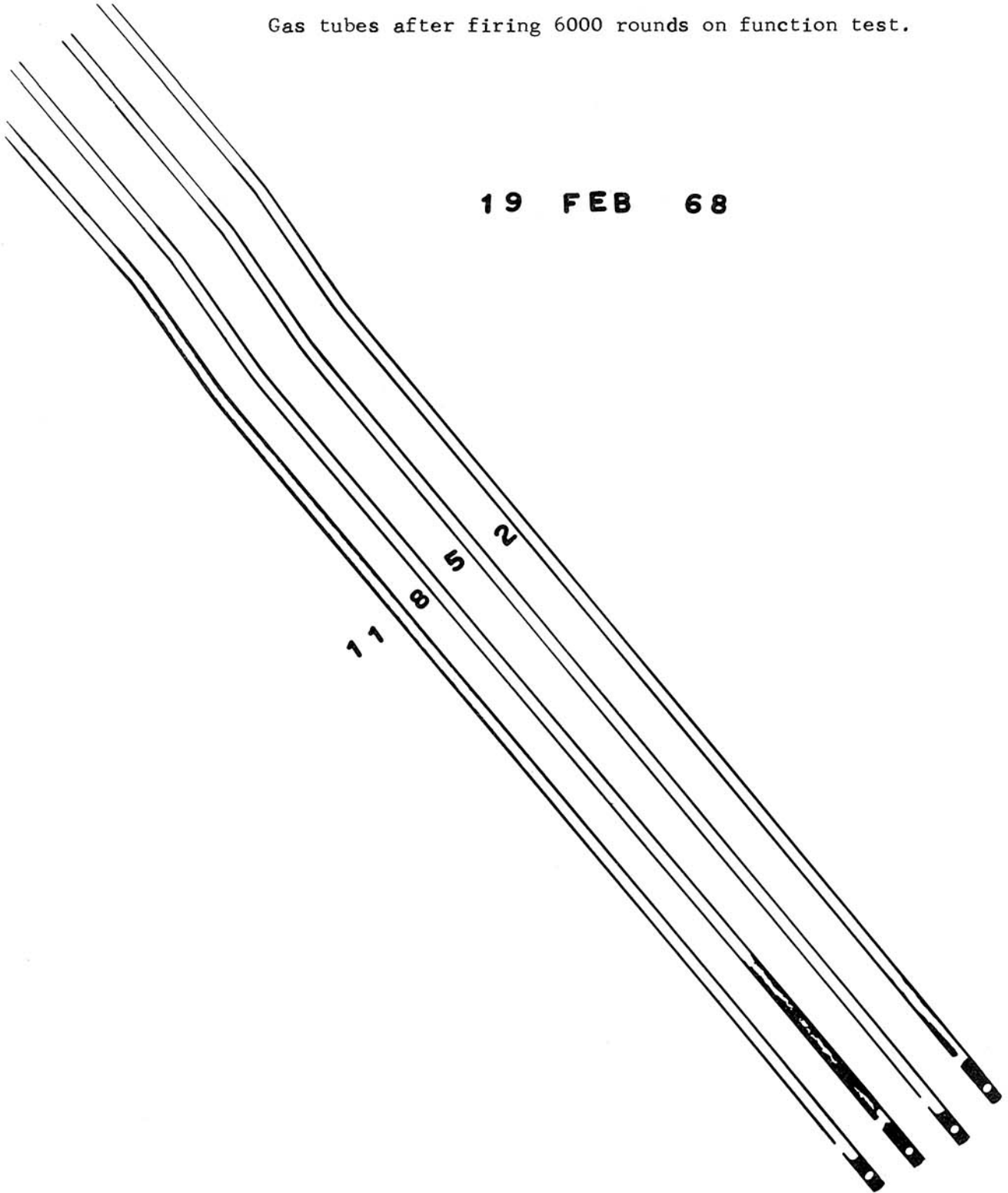

Gas tubes after firing 7000 rounds on function test.
Tube 8 was used in firing 6500 rounds on the function
test and tube 8A was used in firing 500 rounds.

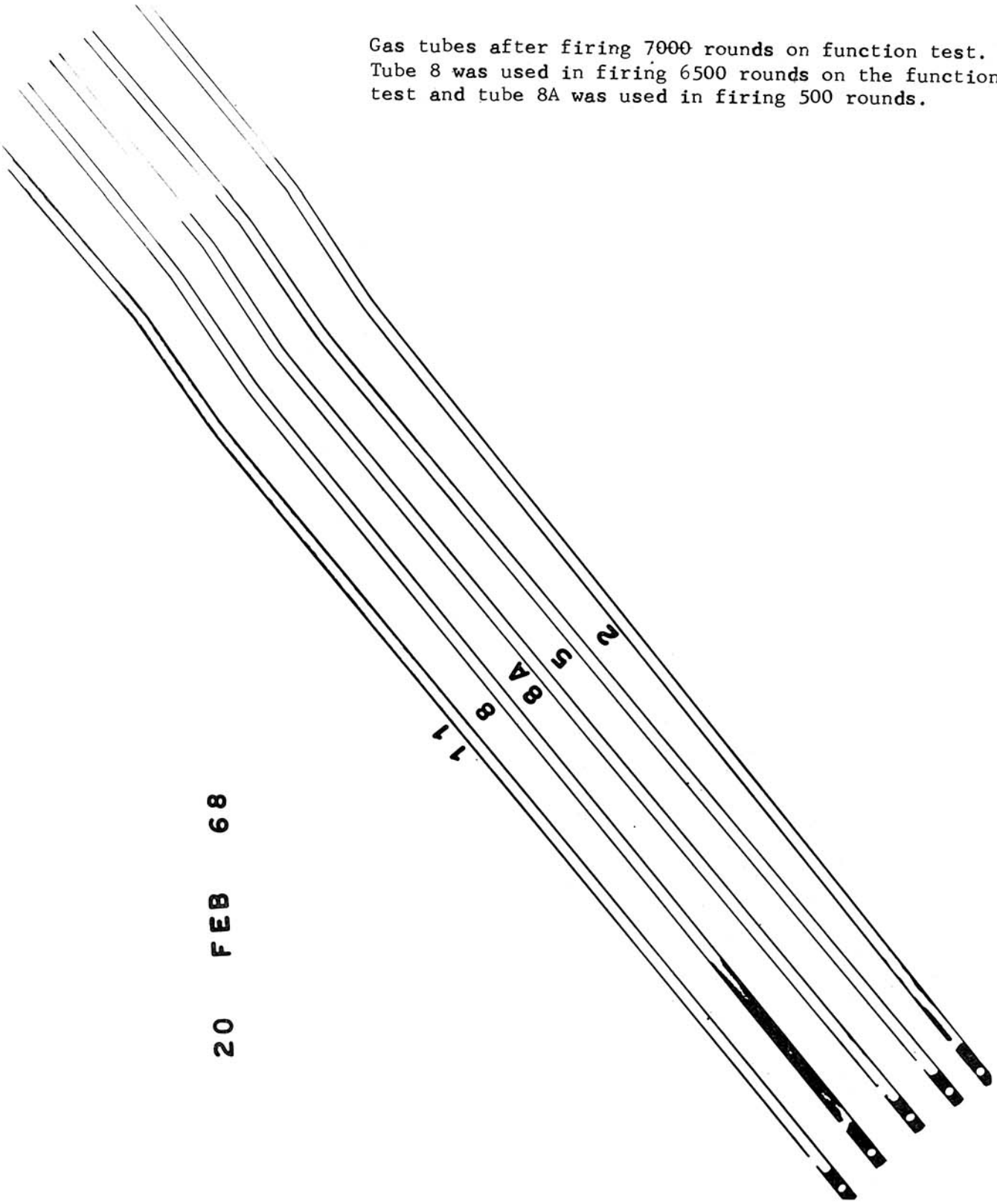

20 FEB 68

Gas tubes after firing 8000 rounds on function test.
Tube 8A was used in firing 1500 rounds on the function
test.

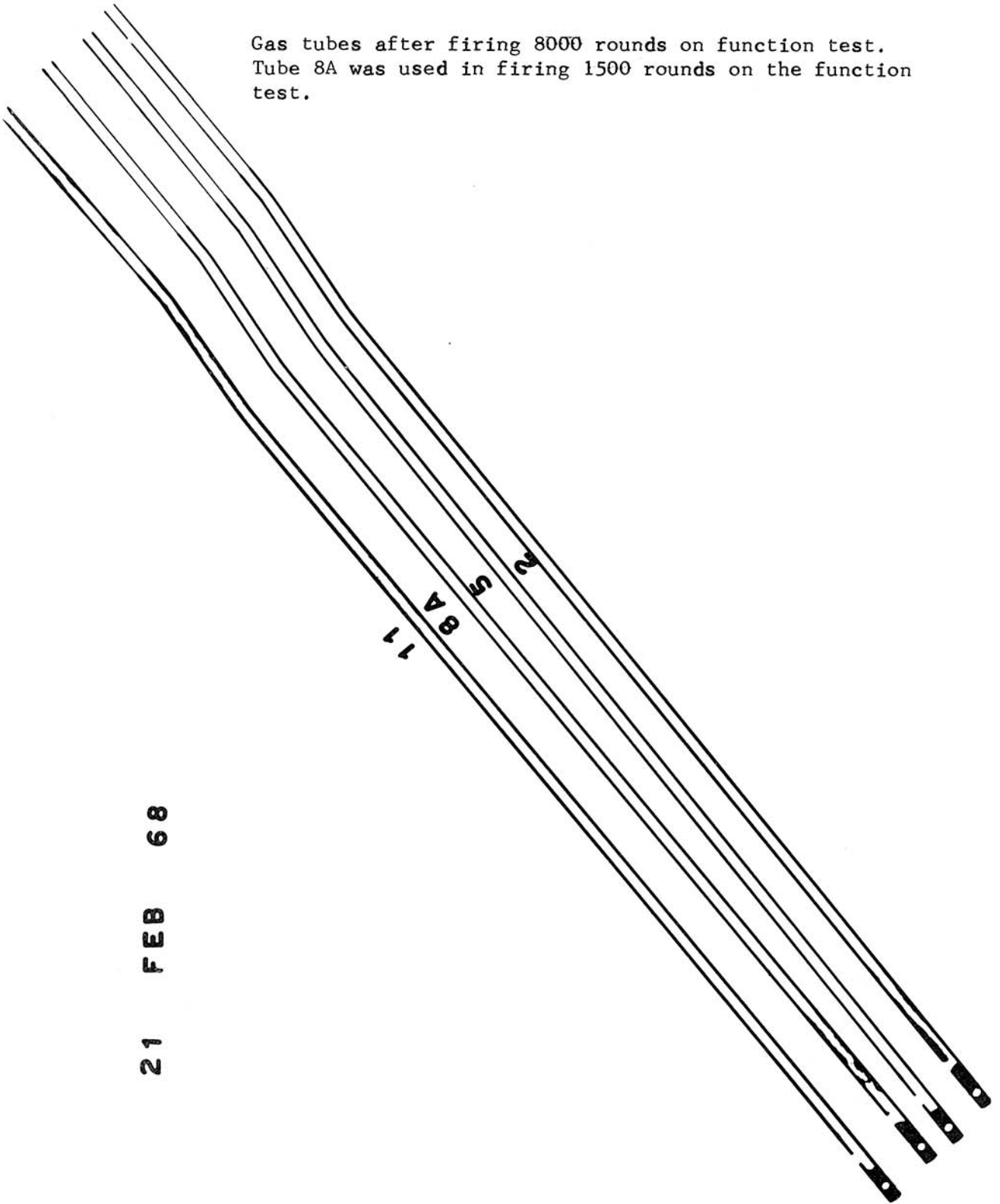

21 FEB 68

Gas tubes after firing 10,000 rounds on function test. Tube 8A was used in firing 3,500 rounds on the function test.

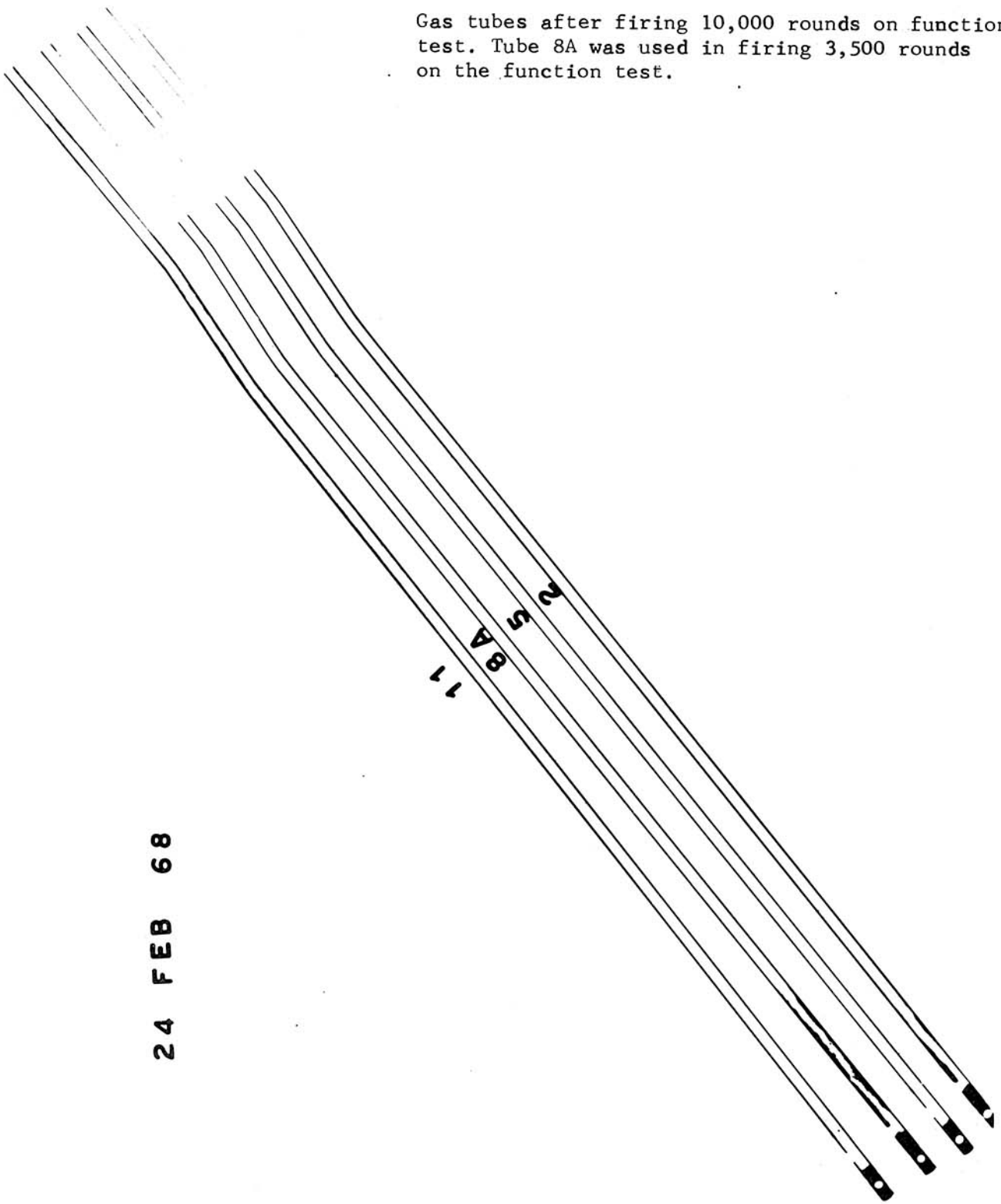

24 FEB 68

Gas tubes after firing 2,000 rounds on function test.

FEB 27 68

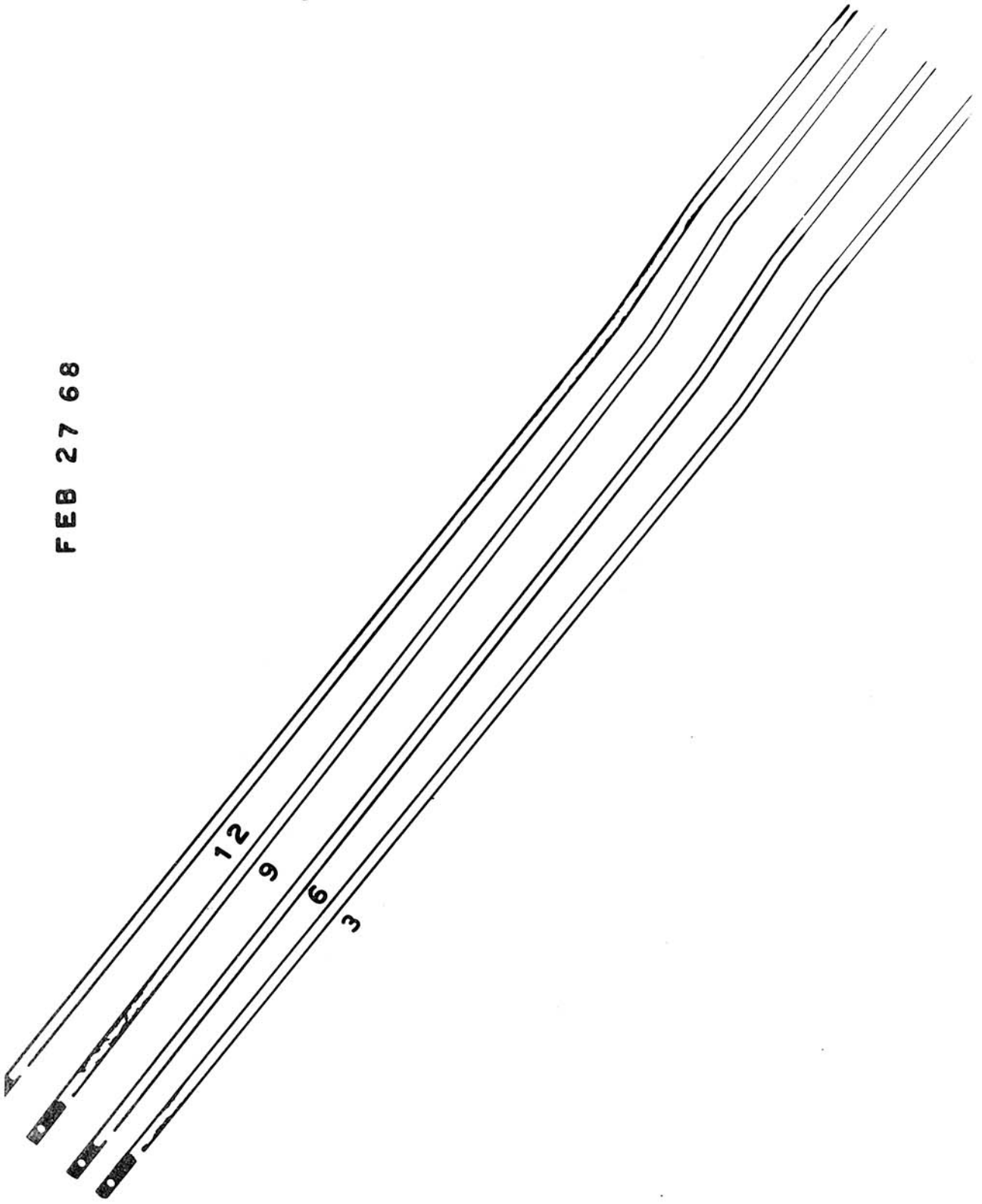

Gas tubes after firing 4,000 rounds on function test.

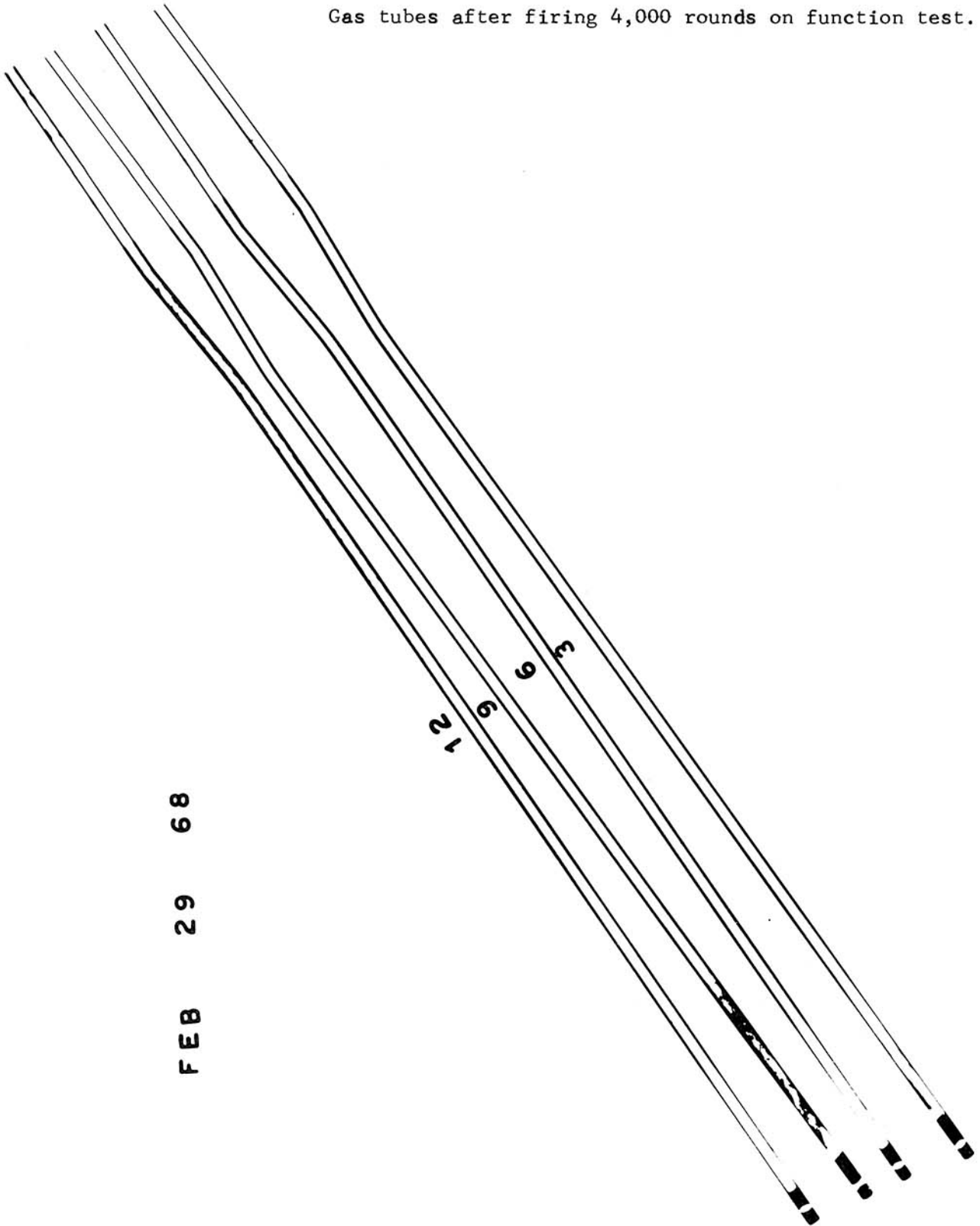

FEB 29 68

Gas tubes after firing 5,000 rounds on function test.
Tube 9B is new.

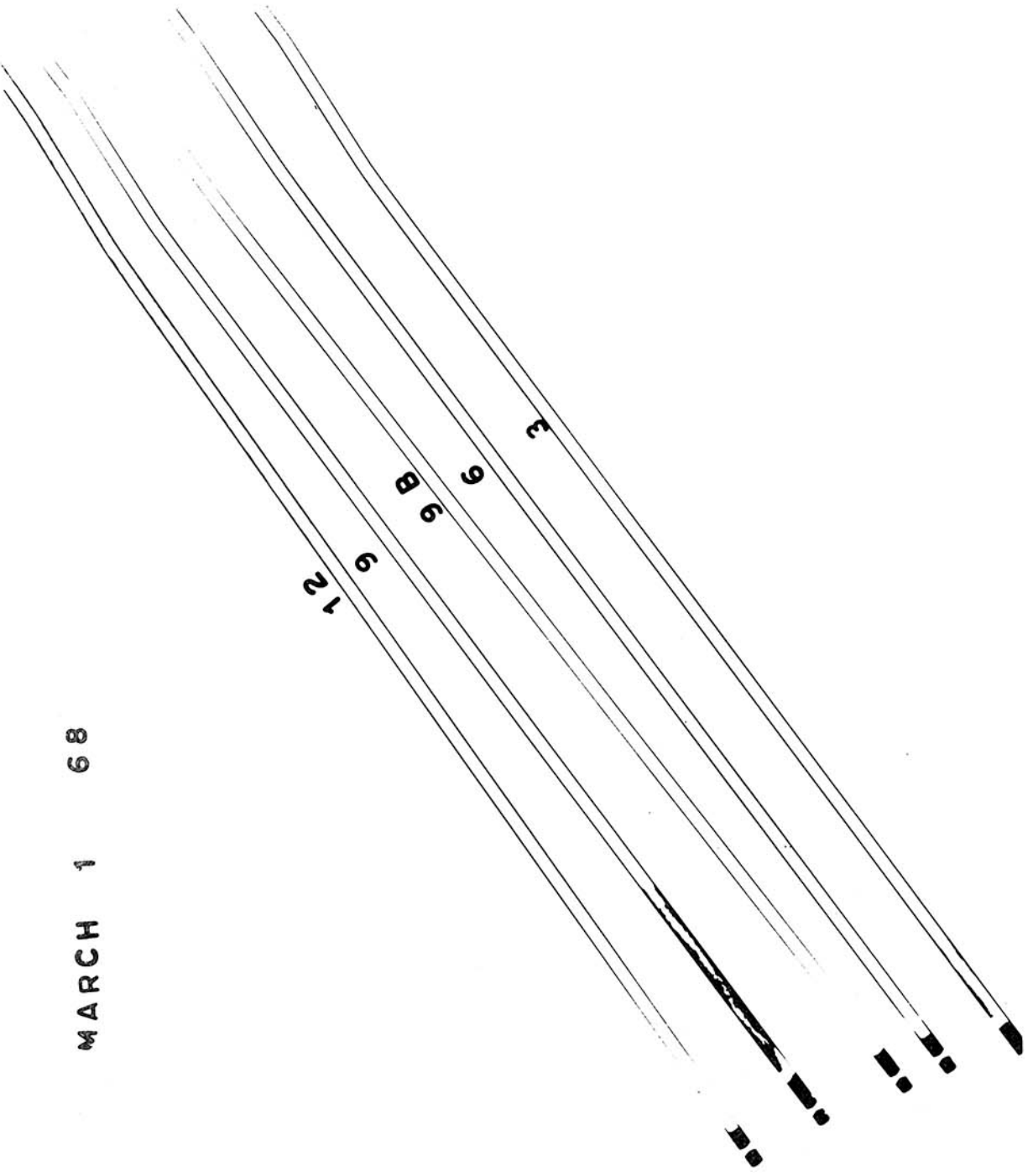

MARCH 1 68

Gas tubes after firing 6,000 rounds on function test. Tube 9B was used in firing 1,000 rounds on the function test.

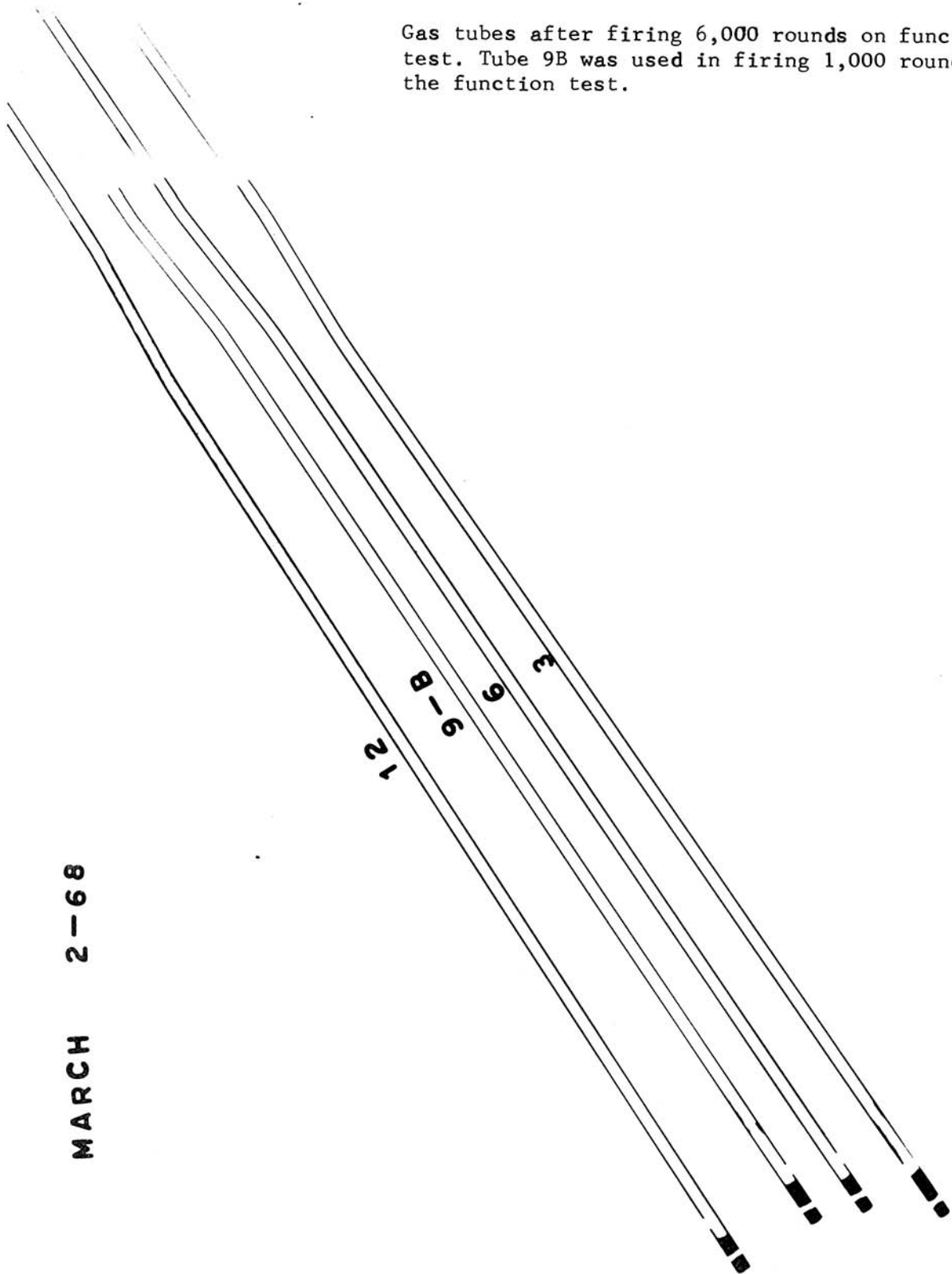

MARCH 2-68

Gas tubes after firing 8,000 rounds on function test. Tube 9B was used in firing 3,000 rounds on the function test.

6 MARCH 68

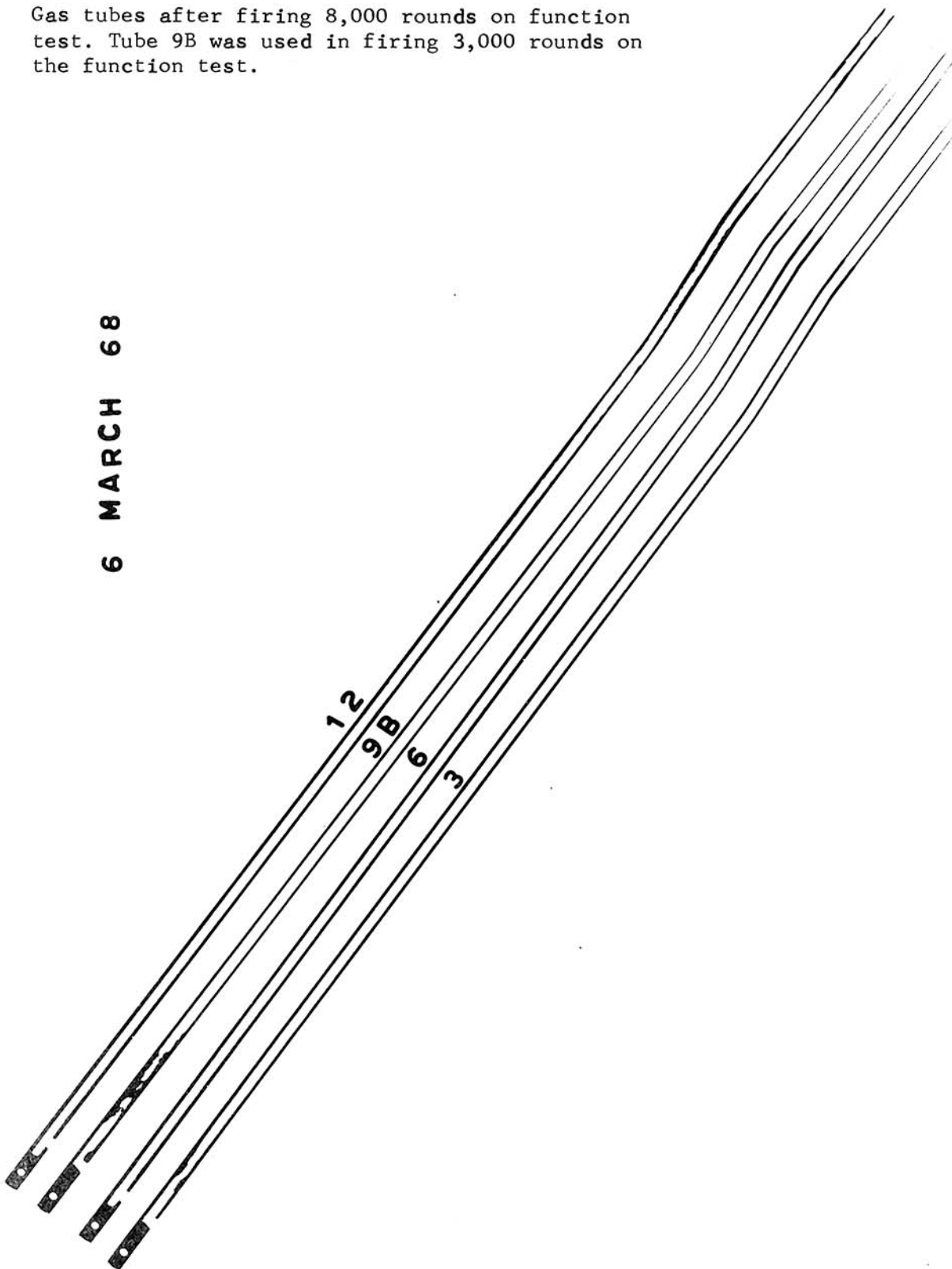

Gas tubes after firing 10,000 rounds on function test. Tube 9B was used in firing 4,200 rounds on the function test.

8 MARCH 68

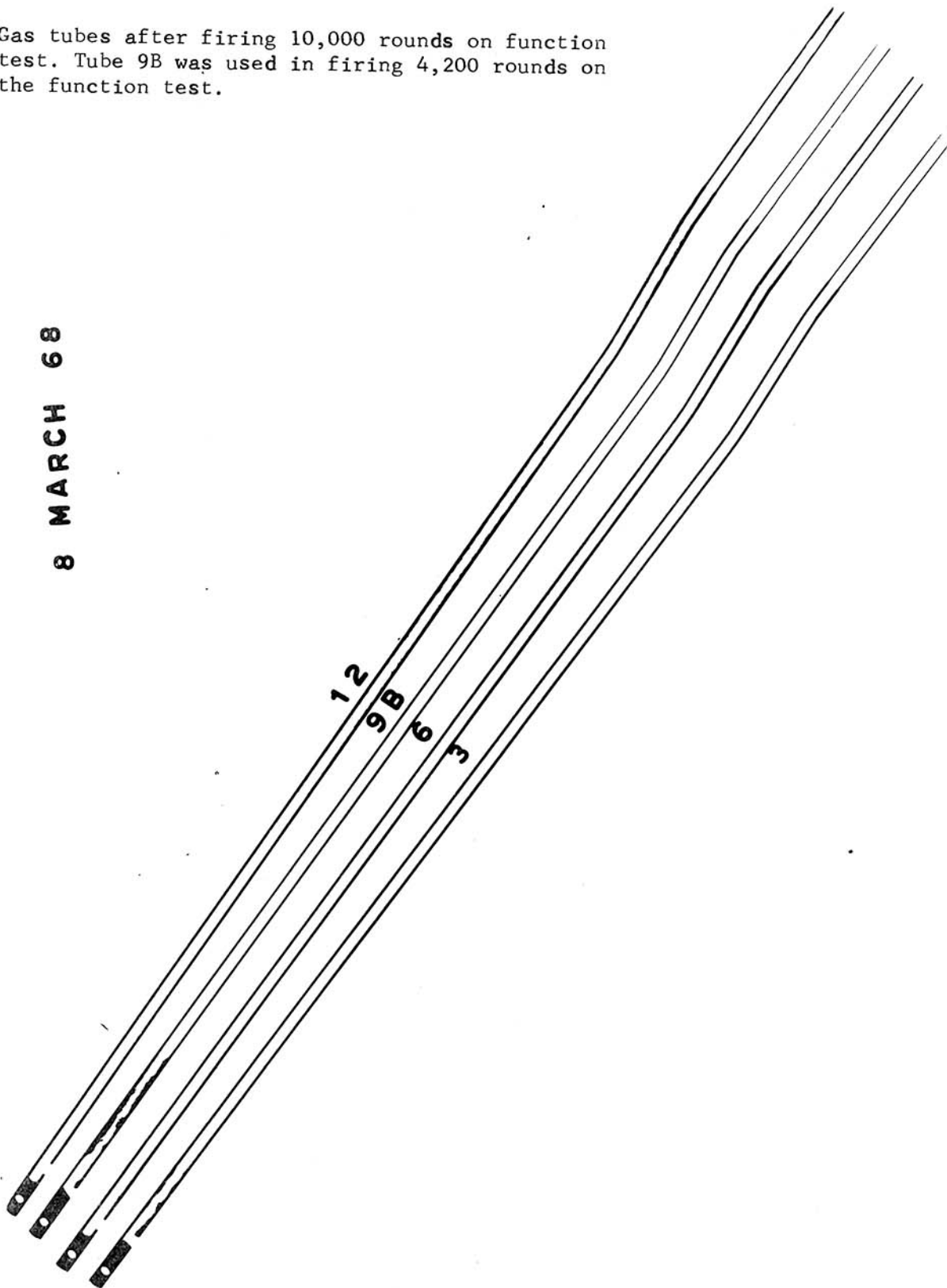

REPRESENTATIVE LABORATORY REPORT
OF FOULING RESIDUE

U S ARMY FRANKFORD ARSENAL
BASIC MATERIALS EVALUATION LABORATORY (Q6100)
QUALITY ASSURANCE DIRECTORATE
LABORATORY REPORT

NO. 155912 DATE 2 May 1968
 MATERIAL Fouling Residue
 REPRESENTING Four (4) Gas Tubes - M16 LOT NO. _____ P. O. _____
 FROM _____ TO Mr. J. Daily, Q3000-235-3 ✓
 SPECIFICATION & DATE _____ x.o. 88405-93-061

CHEMICAL ANALYSIS

Results in Milligrams

	<u>As-received total weight of tube</u>	<u>Weight after sectioning</u>	<u>Fouling removed from section</u>	<u>Probable fouling residue in as-re- ceived tube#</u>
Tube #1	27556.5	17309.0	253.0	402.8
#4	28043.2	18256.6	153.7	236.1
#7	27969.0	17849.4	399.4	625.8
#10	27800.0	17598.1	226.1	357.2

Determined by calculation:

$$\text{Probable fouling residue} = \frac{(\text{Fouling removed from section}) \times (\text{As-received wt. of tube})}{(\text{sectional tube with fouling})}$$

(See Sheet #2)

U S ARMY FRANKFORD ARSENAL
 BASIC MATERIALS EVALUATION LABORATORY (Q6100)
 QUALITY ASSURANCE DIRECTORATE

LABORATORY REPORT

155912 (Sheet #2)

NO. _____ DATE _____

MATERIAL _____

REPRESENTING _____ LOT NO. _____ P. O. _____

FROM _____ TO _____

SPECIFICATION & DATE _____ X.O. _____

SPECTROGRAPHIC ANALYSIS of FOULING
 Estimated concentration in Percent

	<u>Tube #1</u>	<u>#4</u>	<u>#7</u>	<u>#10</u>
Copper	>10	>10	>10	>10
Calcium	5/10	.2/.5	5/10	.3/.7
Lead	2/5	5/10	2/5	>10
Iron	2/4	2/4	2/4	4/8
Zinc	.8/1.5	.5/.9	.8/1.5	.8/1.5
Chromium	1/3	2/5	1/3	2/5
Potassium	.2/.5	1/3	.3/.7	.8/1.5
Barium	.5/.9	.2/.5	.5/1.5	.1/.3
Nickel	.2/.5	.2/.5	.2/.5	.2/.5
Silicon	.1/.3	.1/.3	.1/.3	.1/.3
Magnesium	.1/.3	<.05	.1/.3	.1/.3
Sodium	1/3	.1/.3	.5/.9	.8/1.5
Antimony	ND	.2/.5	ND	1/3
Aluminum	<.1	<.1	.1/.3	.1/.3
Tin	<.05	<.05	<.05	<.05
Manganese	<.05	<.05	<.05	<.05
Vanadium	<.05	ND	<.05	<.05
Strontium	<.05	ND	<.05	ND
Lithium	ND	<.05	ND	<.05
Titanium	ND	<.05	<.05	ND
Molybdenum	<.05	<.05	<.05	<.05
Cobalt	<.05	<.05	<.05	<.05
Silver	ND	ND	ND	<.02
Bismuth	ND	ND	ND	<.03

> - Greater than
 < - Less than
 ND - None detected

For Information Only:

GEORGE NORWITZ, Chemist

Report Approved: 

W. A. SHEBEST
 Actg. Chf. Basic Materials Evaluation Laboratory

APPENDIX G

FUNCTION AND CASUALTY DATA

An "order" number, shown in parentheses after the serial number, was assigned to each rifle for convenient identification.

LEGEND

FF = Failure to feed round from magazine
FJ = Failure to eject
FS = Failure to strip round from magazine
FX = Failure to extract
BOB = Bolt over-rode base of round in feeding from magazine
FBR = Failure of bolt to remain at rear after firing last round
FFR = Failure to fire
F2R = Fired 2 rounds with one rearward movement of the trigger and with the charge lever set for semiautomatic fire
SAT = Satisfactory

The set of headspace gages available for this exercise did not contain a 1.505-inch gage and because of this the headspace for a chamber which accepted the 1.504-inch gage freely but failed to accept the 1.506-inch gage was recorded 1.504+.

The spring rates were determined prior to this test by Mr. John Duffy.

<u>Time</u>	<u>Gunner</u>	<u>Rds</u>	<u>Total Rds</u>	<u>Function</u>	<u>Cyclic Rate (Rds/Min)</u>	<u>Remarks</u>
Rifle, 5.56mm, M16A1, No. 843489					(1)	
Cartridge, 5.56mm, Ball, M193, Lot No. RA5244						
10 January 1968						
The rifle was inspected						
Headspace 1.502 in.						
Firing pin protrusion 0.033 in.						
Firing pin indent 0.023 in.						
Firing pin diameter 0.060 in.						
Firing pin hole diameter in bolt 0.063 in.						
Free length of ejector spring 0.92 in.						
Free length of extractor spring 0.22 in.						
Free length of action spring 12.1 in.						
Action spring rate 1.57 lbs./in.						
31 January 1968						
1313 to 1404	Jastrzemski	50	50	SAT		Accuracy Test
1 February 1968						
0905 to 0910	Folweiler	100	150	SAT	848	
0930 to 0932		100	250	SAT	829	
0950 to 0952		100	350	SAT	829	
1016 to 1018		100	450	SAT	820	
1041 to 1043		100	550	SAT	829	
The bolt group was removed and lubricated. The firing pin was difficult to remove.						
1110 to 1112		100	650	SAT	854	
1131 to 1133		100	750	SAT	864	Breech sparks on 1 rd
1239 to 1241		100	850	SAT	829	
1255 to 1257		100	950	SAT	851	
1313 to 1315		100	1050	SAT	832	
The bolt group was removed and lubricated. The gas tube was removed and subjected to X-ray, air flow measurement, and weighing. Headspace 1.504+ in.						
1612 to 1614		100	1150	SAT	864	
1630 to 1632		100	1250	SAT	857	
1652 to 1654		100	1350	SAT	857	
1711 to 1713		100	1450	SAT	838	
1735 to 1737		100	1550	SAT	829	
The bolt group was removed and lubricated.						
1826 to 1828		100	1650	SAT	860	
1843 to 1845		100	1750	SAT	810	
1900 to 1902		100	1850	SAT	741	
1918 to 1920		100	1950	SAT	717	
1935 to 1937		100	2050	SAT	706	

<u>Time</u>	<u>Gunner</u>	<u>Rds</u>	<u>Total Rds</u>	<u>Function</u>	<u>Cyclic Rate (Rds/Min)</u>	<u>Remarks</u>
2 February 1968						
The rifle was disassembled, cleaned, inspected and lubricated.						
Headspace 1.504+ in.						
Firing pin protrusion 0.034 in.						
Firing pin indent 0.023 in.						
Firing pin diameter 0.060 in.						
Firing pin hole diameter in bolt 0.063 in.						
Fire length of ejector spring 0.87 in.						
Fire length of extractor spring 0.22 in.						
Fire length of action spring 12.1 in.						
The stock was damaged at the points of contact (both sides) with the Springfield Armory firing jack.						
1300 to 1325	Jastrzembski	50	2100	SAT		Accuracy Test
3 February 1968						
0830 to 0832	Steele	100	2200	SAT	860	
0856 to 0858		100	2300	SAT	867	
0915 to 0917		100	2400	SAT	857	
0932 to 0934		100	2500	SAT	841	
0950 to 0952		100	2600	SAT	829	
The bolt group was removed and lubricated.						
1011 to 1013		100	2700	SAT	874	
1031 to 1033		100	2800	SAT	864	
1049 to 1051		100	2900	SAT	857	
1110 to 1112		100	3000	SAT	838	
1129 to 1131		100	3100	SAT	816	
The bolt group was removed and lubricated. The gas tube was subjected to X-Ray, air flow measurement and weighing. Headspace 1.504+ in.						
1430 to 1435		99	3199	1-BOB	838	Stoppage w/mag. 1E
1446 to 1452		99	3298	1-BOB	831	Stoppage w/mag. 1E
1515 to 1517		100	3398	SAT	838	
1536 to 1539		99	3497	1-BOB	836	Stoppage w/mag. 1E
Magazine 1E was replaced with 1E1.						
1607 to 1609		100	3597	SAT	823	
The bolt group was removed and lubricated.						
1732 to 1734		100	3697	SAT	877	
1748 to 1750		100	3797	SAT	884	
1810 to 1812		100	3897	SAT	870	
1830 to 1832		100	3997	SAT	838	1 Split case.
1856 to 1858		100	4097	SAT	823	

<u>Time</u>	<u>Gunner</u>	<u>Rds</u>	<u>Total Rds</u>	<u>Function</u>	<u>Cyclic Rate (Rds/Min)</u>	<u>Remarks</u>
0845 to 0849	5 February 1968 Jastrzemski	50	4247	SAT		Accuracy Test
The rifle was disassembled, cleaned, inspected and lubricated.						
Headspace 1.504+in.						
Firing pin protrusion 0.034 in.						
Firing pin indent 0.021 in.						
Firing pin diameter 0.060 in.						
Firing pin hole diameter in bolt 0.063 in.						
Free length of ejector spring 0.86 in.						
Free length of extractor spring 0.21 in.						
Free length of action spring 12.1 in.						
6 February 1968						
0845 to 0849	Sneade	100	4347	SAT	864	
0907 to 0910		100	4347	SAT	854	
0937 to 0940		100	4447	SAT	848	
1000 to 1003		100	4547	SAT	841	
1025 to 1029		100	4647	1-BOB	819	Stoppage w/mag. 1E1
The bolt group was removed and lubricated.						
1108 to 1110		100	4747	SAT	860	
1127 to 1129		100	4847	SAT	860	
1308 to 1310		100	5047	SAT	867	
1400 to 1403		100	5147	SAT	848	
The bolt group was removed and lubricated. The gas tube was subjected to X-Ray, air flow measurement and weighing. Headspace 1.504+ in.						
1625 to 1627		100	5247	SAT	877	Breech sparks on 3 rds.
1642 to 1644		100	5347	1-FBR	880	Malfunction w/mag. 1D
1703 to 1705		100	5447	SAT	884	
1727 to 1729		100	5547	SAT	877	
1748 to 1750		100	5647	SAT	857	
The bolt group was removed and lubricated.						
1843 to 1845		100	5747	SAT	887	
1856 to 1858		100	5847	SAT	887	
1917 to 1919		100	5947	SAT	877	
1938 to 1940		100	6047	SAT	860	
1955 to 1957		100	6147	SAT	864	

<u>Time</u>	<u>Gunner</u>	<u>Rds</u>	<u>Total Rds</u>	<u>Function</u>	<u>Cyclic Rate (Rds/Min)</u>	<u>Remarks</u>
7 February 1968						
0826 to 0852	Jastrzembki	50	6197	SAT		Accuracy Test
The rifle was disassembled, cleaned, inspected and lubricated.						
Headspace 1.504+in.						
Firing pin protrusion 0.035 in.						
Firing pin indent 0.021 in.						
Firing pin diameter 0.060 in.						
Firing pin hole diameter in bolt 0.063 in.						
Free length of ejector spring 0.86 in.						
Free length of extractor spring 0.20 in.						
Free length of action spring 12.1 in.						
8 February 1968						
0836 to 0838	Folweiler	100	6297	SAT	870	
0858 to 0900		100	6397	1-BOB	860	Stoppage w/mag. ID
0917 to 0919		100	6497	SAT	859	
0951 to 0953		100	6597	SAT	848	
1004 to 1006		100	6697	SAT	864	
The bolt group was removed and lubricated.						
1042 to 1044		100	6797	SAT	880	
1058 to 1100		100	6897	1-BOB	820	Stoppage w/mag. 1E1
1117 to 1119		100	6997	SAT	880	
1257 to 1259		100	7097	SAT	867	
1315 to 1317		100	7197	SAT	882	
The bolt group was disassembled and lubricated. The gas tube was subjected to X-Ray, air flow measurement and weighing. Headspace 1.504+ in.						
1618 to 1620		100	7297	SAT	552	
The gas tube retaining pin was missing. It was replaced.						
1639 to 1708		100	7397	4-FJ	884	1 stoppage w/mag. 1A & 3 w/mag. 1B
The rifle was inspected after the fourth stoppage.						
The ejector spring was bent and it was binding in the bolt.						
The extractor spring was broken. Both springs were replaced.						
Free length of new ejector spring 0.92 in.						
Free length of new extractor spring 0.26 in.						
1723 to 1725		100	7497	SAT	896	
1740 to 1742		100	7597	SAT	879	
1752 to 1754		100	7697	SAT	849	
The bolt group was removed and lubricated.						
1834 to 1836		100	7797	SAT	907	
1850 to 1852		100	7897	SAT	907	1 large muzzle flash
1910 to 1912		100	7997	SAT	905	1 large muzzle flash
1930 to 1932		100	8097	SAT	879	
1950 to 1952		100	8197	SAT	864	

Time	Gunner	Rds	Total Rds	Function	Cyclic Rate (Rds/Min)	Remarks
9 February 1968						
0830 to 0900	Jastrzemski	50	8247	SAT		Accuracy Test
The rifle was disassembled, cleaned, inspected and lubricated.						
Headspace 1.504+ in.						
Firing pin protrusion 0.035 in.						
Firing pin indent 0.022 in.						
Firing pin diameter 0.059 in.						
Firing pin hole diameter in bolt 0.063 in.						
Free length of ejector spring 0.86 in.						
Free length of extractor spring 0.20 in.						
Free length of action spring 12.1 in.						
10 February 1968						
0843 to 0845	Steele	100	8347	SAT	907	
0902 to 0906		100	8447	1-BOB	872	Stoppages w/mag. 1E1
				1-FJ		
0924 to 0927		100	8547	1-FJ	879	Stoppage w/mag. 1D Breech sparks on 1 rd.
0944 to 0946		100	8647	SAT	889	
1004 to 1006		100	8747	1-FJ	880	Stoppage w/mag. 1D
The bolt group was removed and lubricated.						
1047 to 1049		100	8847	SAT	927	
1110 to 1112		100	8947	SAT	919	
1130 to 1132		100	9047	SAT	908	
1250 to 1254		100	9147	1-FFR	843	Stoppage w/mag. 1E1 The bolt failed to lock.
1313 to 1319		100	9247	3-FFR 1-FBR	838	Stoppages w/mag. 1D & FBR w/mag. 1E1 Stop- pages caused by failure of bolt to lock.
The bolt group was removed and lubricated. The gas tube was subjected to X-Ray, air flow measurement and weighing. Headspace 1.504+ in.						
The firing pin was difficult to remove.						
1620 to 1622		100	9347	SAT	916	
1640 to 1643		100	9447	1-BOB	887	Stoppage w/mag 1C
1706 to 1708		100	9547	SAT	880	
1726 to 1728		100	9647	SAT	837	
1755 to 1757		100	9747	SAT	831	
The bolt group was removed and lubricated.						
1852 to 1854		100	9847	SAT	898	
1910 to 1912		100	9947	SAT	903	
1938 to 1940		100	10,047	SAT	887	
1952 to 1954		100	10,147	SAT	875	
2007 to 2009		100	10,247	SAT	852	

<u>Time</u>	<u>Gunner</u>	<u>Rds</u>	<u>Total Rds</u>	<u>Function</u>	<u>Cyclic Rate (Rds/Min)</u>	<u>Remarks</u>
0842 to 0908	Jastrzemski	50	10,297	SAT		Accuracy Test

12 February 1968

The rifle was diassambled, cleaned, inspected and lubricated.
 Headspace 1.504+ in.

Firing pin protrusion 0.035 in.

Firing pin indent 0.023 in.

Firing pin diameter 0.059 in.

Firing pin hole diameter in bolt 0.063 in.

Free length of ejector spring 0.84 in.

Free length of extractor spring 0.20 in.

Free length of action spring 12.1 in.

Time	Gunner	Rds	Total Rds	Function	Cyclic Rate (Rds/Min)	Remarks
Rifle, 5.56mm, M16A1, No. 848305 (2)						
Cartridge, 5.56mm, Ball, M193, Lot No. RA5244						
9 January 1968						
The rifle was inspected.						
Headspace 1.500 in.						
Firing pin protrusion 0.034 in.						
Firing pin indent 0.021 in.						
Firing pin diameter 0.060 in.						
Firing pin hole diameter in bolt 0.062 in.						
Free length of ejector spring 0.92 in.						
Free length of extractor spring 0.24 in.						
Free length of action spring 12.2 in.						
Action spring rate 1.43 lbs/in.						
12 February 1968						
1303 to 1332	Jastrzemski	50	50	SAT		Accuracy Test
13 February 1968						
0852 to 0854	Sneade	100	150	SAT	887	
0912 to 0914		100	250	SAT	898	
0950 to 0957		100	350	1-FS	854	Stoppage w/mag. 2D (1st rd)
1016 to 1018		100	450	SAT	874	
1042 to 1044		100	550	SAT	891	Breech sparks on 1 rd
The bolt group was removed and lubricated.						
1122 to 1124		100	650	SAT	901	
1134 to 1136		100	750	SAT	910	
1257 to 1259		100	850	SAT	875	
1310 to 1312		100	950	SAT	864	
1323 to 1325		100	1050	SAT	848	
The bolt group was removed and lubricated. The gas tube was subjected to X-Ray, air flow measurement and weighing. Headspace 1.501 in.						
1616 to 1618		100	1150	SAT	887	
1638 to 1640		100	1250	SAT	885	
1701 to 1703		100	1350	SAT	882	
1721 to 1723		100	1450	SAT	885	
1734 to 1736		100	1550	SAT	870	
The bolt group was removed and lubricated.						
1837 to 1839		100	1650	SAT	910	
1852 to 1854		100	1750	SAT	889	
1909 to 1911		100	1850	SAT	870	
1928 to 1930		100	1950	SAT	872	
1946 to 1948		100	2050	SAT	849	

<u>Time</u>	<u>Gunner</u>	<u>Rds</u>	<u>Total Rds</u>	<u>Function</u>	<u>Cyclic Rate (Rds/Min)</u>	<u>Remarks</u>
14 February 1968						
0830 to 0900	Jastrzemski	50	2100	SAT		Accuracy Test
The rifle was disassembled, cleaned, inspected and lubricated.						
Headspace 1.501 in.						
Firing pin protrusion 0.035 in.						
Firing pin indent 0.022 in.						
Firing pin diameter 0.060 in.						
Firing pin hole diameter in bolt 0.063 in.						
Free length of ejector spring 0.88 in.						
Free length of extractor spring 0.22 in.						
Free length of action spring 12.1 in.						
The stock was cracked on the left side at the point of contact with the Springfield Armory firing jack.						
15 February 1968						
0842 to 0844	Folweiler	100	2200	SAT	885	
0904 to 0906		100	2300	SAT	880	
0932 to 0934		100	2400	SAT	885	
0952 to 0954		100	2500	SAT	889	
1018 to 1020		100	2600	SAT	891	
The bolt group was removed and lubricated.						
1058 to 1100		100	2700	SAT	908	
1121 to 1123		100	2800	SAT	898	
1247 to 1249		100	2900	SAT	Not recorded	
1312 to 1315		100	3000	SAT	879	
1327 to 1329		100	3100	SAT	870	
The bolt group was removed and lubricated. The gas tube was subjected to X-Ray, air flow measurement and weighing. Headspace 1.501 in.						
1615 to 1617		100	3200	SAT	894	
1635 to 1637		100	3300	SAT	901	
1655 to 1657		100	3400	SAT	872	
1715 to 1717		100	3500	SAT	852	Muzzle flash on 1 rd
1736 to 1738		100	3600	SAT	859	
The bolt group was removed and lubricated.						
1838 to 1840		100	3700	SAT	905	
1853 to 1855		100	3800	SAT	872	Muzzle flash on 1 rd.
1912 to 1914		100	3900	SAT	857	Muzzle flash on 1 rd.
1932 to 1934		100	4000	SAT	864	Breech sparks on 1 rd.
The snap ring was lost and this permitted the ejection port cover pin to disengage at its forward end.						
1951 to 1953		100	4100	SAT	865	

<u>Time</u>	<u>Gunner</u>	<u>Rds</u>	<u>Total Rds</u>	<u>Function</u>	<u>Cyclic Rate (Rds/Min)</u>	<u>Remarks</u>
16 February 1968						
0830 to 0854	Jastrzemski	50	4150	SAT		Accuracy Test
The rifle was disassembled, cleaned, inspected and lubricated.						
Headspace 1.502 in.						
Firing pin protrusion 0.035 in.						
Firing pin indent 0.022 in.						
Firing pin diameter 0.060 in.						
Firing pin hole diameter in bolt 0.063 in.						
Free length of ejector spring 0.90 in.						
Free length of extractor spring 0.20 in.						
Free length of action spring 12.1 in.						
17 February 1968						
0830 to 0832	Steele	100	4250	SAT		Not Recorded Mag. 2A was difficult
to insert in and remove from the rifle.						
0848 to 0850		100	4350	SAT	921	
0909 to 0911		100	4450	SAT	901	
0928 to 0930		100	4550	SAT	916	
0951 to 0953		100	4650	SAT	898	
The bolt group was removed and lubricated.						
Magazine 2A was replaced with 2A1.						
1038 to 1040		100	4750	SAT	950	
1058 to 1100		100	4850	SAT	916	
1120 to 1122		100	4950	SAT	880	
1254 to 1256		100	5050	SAT	867	
1322 to 1325		100	5150	SAT	912	
The bolt group was removed and lubricated. The gas tube was subjected to						
X-Ray, air flow measurement and weighing. Headspace 1.502 in.						
1600 to 1602		100	5250	SAT	925	
1624 to 1626		100	5350	SAT	933	Breech sparks on 1 rd
1649 to 1651		100	5450	SAT	889	
1715 to 1717		100	5550	SAT	882	
1735 to 1737		100	5650	SAT	874	
The bolt group was removed and lubricated.						
1831 to 1833		100	5750	SAT	934	
1853 to 1855		100	5850	SAT	927	
1915 to 1917		100	5950	SAT	884	
1938 to 1940		100	6050	SAT	857	
1956 to 1958		100	6150	SAT	854	

<u>Time</u>	<u>Gunner</u>	<u>Rds</u>	<u>Total Rds</u>	<u>Function</u>	<u>Cyclic Rate (Rds/Min)</u>	<u>Remarks</u>
19 February 1968						
0830 to 0900	Jastrzemski	50	6200	SAT		Accuracy Test
The rifle was disassembled, cleaned, inspected and lubricated.						
Headspace 1.502 in.						
Firing pin protrusion 0.035 in.						
Firing pin indent 0.022 in.						
Firing pin diameter 0.060 in.						
Firing pin hole diameter in bolt 0.063 in.						
Free length of ejector spring 0.88 in.						
Free length of extractor spring 0.22 in.						
Free length of action spring 12.1 in.						
A new snap ring was installed to retain the ejection port cover pin.						
20 February 1968						
0841 to 0843	Sneade	100	6300	SAT	929	
0905 to 0907		100	6400	SAT	899	Muzzle flash on 1 rd
Magazines 2A and 2C were difficult to insert in and remove from the rifle.						
0921 to 0923		100	6500	SAT	907	
0950 to 0952		100	6600	SAT	907	
1022 to 1024		100	6700	SAT	877	
The bolt group was removed and lubricated.						
1116 to 1118		100	6800	SAT	934	
1131 to 1133		100	6900	SAT	931	
1250 to 1252		100	7000	SAT	865	
1309 to 1311		100	7100	SAT	901	1 Split case
1325 to 1327		100	7200	SAT	865	
The bolt group was removed and lubricated. The gas tube was subjected to X-Ray, air flow measurement and weighing. Headspace 1.502 in.						
1556 to 1558		100	7300	SAT	892	
1624 to 1626		100	7400	SAT	885	
1645 to 1647		100	7500	SAT	885	
1709 to 1711		100	7600	SAT	884	
1732 to 1734		100	7700	SAT	898	
The bolt group was removed and lubricated.						
1832 to 1834		100	7800	SAT	933	
1851 to 1853		100	7900	SAT	950	
1914 to 1916		100	8000	SAT	910	
1935 to 1937		100	8100	SAT	905	
1956 to 1958		100	8200	SAT	907	

<u>Time</u>	<u>Gunner</u>	<u>Rds</u>	<u>Total Rds</u>	<u>Function</u>	<u>Cyclic Rate (Rds/Min)</u>	<u>Remarks</u>
21 February 1968						
0845 to 0915	Jastrzemski	50	8250	SAT		Accuracy Test
The rifle was disassembled, cleaned, inspected and lubricated.						
Headspace 1.502 in.						
Firing pin protrusion 0.035 in.						
Firing pin indent 0.022 in.						
Firing pin diameter 0.060 in.						
Firing pin hole diameter in bolt 0.063.						
Free length of ejector spring 0.88 in.						
Free length of extractor spring 0.22 in.						
Free length of action spring 12.1 in.						
23 February 1968						
0841 to 0843	Folweiler	100	8350	SAT	908	
0902 to 0904		100	8450	SAT	919	
0919 to 0921		100	8550	SAT	898	
0940 to 0942		100	8650	SAT	872	Muzzle flash on 1 rd
1000 to 1002		100	8750	SAT	879	
The bolt group was removed and lubricated.						
1042 to 1044		100	8850	SAT	925	
1057 to 1059		100	8950	SAT	923	
1115 to 1117		100	9050	SAT	950	
1247 to 1249		100	9150	SAT	910	Muzzle flash on 1 rd
1305 to 1307		100	9250	SAT	Not Recorded	
The bolt group was removed and lubricated. The gas tube was subjected to X-Ray, air flow measurement and weighing. Headspace 1.502 in.						
1545 to 1547		100	9350	SAT	916	
1608 to 1610		100	9450	SAT	931	
1632 to 1634		100	9550	SAT	907	
1657 to 1659		100	9650	SAT	894	Muzzle flash on 1 rd
1727 to 1729		100	9750	SAT	894	
The bolt group was removed and lubricated.						
1839 to 1841		100	9850	2-F2R	916	
1900 to 1902		100	9950	4-F2R	916	
1919 to 1921		100	10,050	2-F2R	889	
1936 to 1938		100	10,150	SAT	864	Breech sparks on 1 rd
1951 to 1953		100	10,250	SAT	826	

<u>Time</u>	<u>Gunner</u>	<u>Rds</u>	<u>Total Rds</u>	<u>Function</u>	<u>Cyclic Rate (Rds/Min)</u>	<u>Remarks</u>
0825 to 0850	Jastrzemski	50	10,300	SAT		Accuracy Test

24 February 1968

The rifle was disassembled, cleaned, inspected and lubricated.
 Headspace 1.502 in.

Firing pin protrusion 0.034 in.

Firing pin indent 0.021 in.

Firing pin diameter 0.060 in.

Firing pin hole diameter in bolt 0.063 in.

Free length of ejector spring 0.87 in.

Free length of extractor spring 0.21 in.

Free length of action spring 12.0 in.

<u>Time</u>	<u>Gunner</u>	<u>Rds</u>	<u>Total Rds</u>	<u>Function</u>	<u>Cyclic Rate (Rds/Min)</u>	<u>Remarks</u>
Rifle, 5.56mm, M16A1, No. 850464 (3)						
Cartridge, 5.56mm, Ball, M193, Lot No. RA5244						
10 January 1968						
The rifle was inspected.						
Headspace 1.501 in.						
Firing pin protrusion 0.033 in.						
Firing pin indent 0.024 in.						
Firing pin diameter 0.060 in.						
Firing pin hole diameter in bolt 0.063 in.						
Free length of ejector spring 0.91 in.						
Free length of extractor spring 0.23 in.						
Free length of action spring 12.1 in.						
Action spring rate 1.43 lbs/in.						
24 February 1968						
1245 to 1315	Jastrzemski	50	50	SAT		Accuracy Test
26 February 1968						
0841 to 0843	Steele	100	150	SAT	925	
0901 to 0903		100	250	SAT	972	
0926 to 0928		100	350	SAT	976	Breech sparks on 1 rd
0950 to 0952		100	450	SAT	965	Breech sparks on 2 rds
1013 to 1015		100	550	SAT	923	
The bolt group was removed and lubricated.						
The firing pin and cam were difficult to remove.						
The stock was cracked on the left side at the point of contact with the Springfield Armory firing jack.						
1050 to 1052		100	650	SAT	949	Muzzle flash on 1 rd
1113 to 1115		100	750	SAT	952	Breech sparks on 1 rd
1131 to 1133		100	850	SAT	954	
1255 to 1257		100	950	SAT	923	
1316 to 1318		100	1050	SAT	931	Muzzle flash on 1 rd
The bolt group was removed and lubricated. The gas tube was subjected to X-Ray, air flow measurement and weighing. Headspace 1.501 in.						
1605 to 1607		100	1150	SAT	948	
1628 to 1630		100	1250	SAT	952	
1654 to 1656		100	1350	SAT	938	
1720 to 1722		100	1450	SAT	929	
1743 to 1745		100	1550	SAT	927	
The bolt group was removed and lubricated.						
1838 to 1840		100	1650	1-FJ	926	
1905 to 1907		100	1750	SAT	944	
1928 to 1930		100	1850	SAT	944	
1947 to 1949		100	1950	SAT	966	
2003 to 2004		100	2050	SAT	908	

<u>Time</u>	<u>Gunner</u>	<u>Rds</u>	<u>Total Rds</u>	<u>Function</u>	<u>Cyclic Rate (Rds/Min)</u>	<u>Remarks</u>
27 February 1968						
0830 to 0857	Jastrzemski	50	2100	SAT		Accuracy Test
The rifle was disassembled, cleaned, inspected and lubricated.						
Headspace 1.502 in.						
Firing pin protrusion 0.033 in.						
Firing pin indent 0.023 in.						
Firing pin diameter 0.060 in.						
Firing pin hole diameter in bolt 0.063 in.						
Free length of ejector spring 0.91 in.						
Free length of extractor spring 0.21 in.						
Free length of action spring 11.9 in.						
28 February 1968						
0834 to 0836	Sneade	100	2200	SAT	934	The snap ring was lost and the ejection port cover pin disengaged at its forward end. The cover was removed.
0900 to 0902		100	2300	SAT	914	
0930 to 0932		100	2400	SAT	887	
0957 to 0959		100	2500	SAT	882	
1020 to 1022		100	2600	SAT	865	
The bolt group was removed and lubricated.						
1055 to 1057		100	2700	SAT	919	
1118 to 1120		100	2800	SAT	929	
1133 to 1135		100	2900	SAT	921	
1247 to 1249		100	3000	SAT	916	
1305 to 1307		100	3100	SAT	914	
The bolt group was removed and lubricated. The gas tube was subjected to X-Ray, air flow measurement and weighing. Headspace 1.502 in.						
1608 to 1612		100	3200	1-FJ	899	
1634 to 1636		100	3300	SAT	950	Breech sparks on 1 rd
1655 to 1657		100	3400	SAT	931	
1720 to 1722		100	3500	SAT	933	
1741 to 1743		100	3600	SAT	925	
The bolt group was removed and lubricated.						
1837 to 1839		100	3700	SAT	952	Muzzle flash on 2 rds
1855 to 1857		100	3800	SAT	950	
1916 to 1918		100	3900	SAT	907	Muzzle flash on 1 rd
1933 to 1935		100	4000	SAT	889	Muzzle flash on 1 rd
1948 to 1950		100	4100	SAT	892	

<u>Time</u>	<u>Gunner</u>	<u>Rds</u>	<u>Total Rds</u>	<u>Function</u>	<u>Cyclic Rate (Rds/Min)</u>	<u>Remarks</u>
29 February 1968						
0830 to 0900	Jastrzemski	50	4150	SAT		Accuracy Test
The rifle was disassembled, cleaned, inspected and lubricated.						
Headspace 1.502 in.						
Firing pin protrusion 0.033 in.						
Firing pin indent 0.023 in.						
Firing pin diameter 0.060 in.						
Firing pin hole diameter in bolt 0.063 in.						
Free length of ejector spring 0.90 in.						
Free length of extractor spring 0.21 in.						
Free length of action spring 11.9 in.						
1 March 1968						
0840 to 0842	Folweiler	100	4250	SAT	934	
0900 to 0902		100	4350	SAT	952	Muzzle flash on 1 rd
0923 to 0925		100	4450	SAT	966	Muzzle flash on 1 rd
0947 to 0949		100	4550	SAT	962	
1008 to 1010		100	4650	SAT	952	
The bolt group was removed and lubricated.						
1044 to 1046		100	4750	SAT	985	
1105 to 1107		100	4850	SAT	991	Muzzle flash on 1 rd
1120 to 1122		100	4950	SAT	958	
1243 to 1245		100	5050	SAT	956	
1306 to 1308		100	5150	SAT	987	
The bolt group was removed and lubricated. The gas tube was subjected to X-Ray, air flow measurement and weighing. Headspace 1.502 in.						
1612 to 1614		100	5250	SAT	958	
1630 to 1632		100	5350	SAT	962	
1653 to 1655		100	5450	SAT	979	
1720 to 1722		100	5550	SAT	987	
1738 to 1740		100	5650	SAT	966	
The bolt group was removed and lubricated.						
1838 to 1840		100	5750	SAT	976	
1859 to 1901		100	5850	SAT	965	Breech sparks on 1 rd
1918 to 1920		100	5950	SAT	938	Muzzle flash on 1 rd
1939 to 1941		100	6050	SAT	894	
1958 to 2000		100	6150	SAT	875	

<u>Time</u>	<u>Gunner</u>	<u>Rds</u>	<u>Total Rds</u>	<u>Function</u>	<u>Cyclic Rate (Rds/Min)</u>	<u>Remarks</u>
2 March 1968						
0830 to 0855	Jastrzembski	50	6200	SAT		Accuracy Test
The rifle was disassembled, cleaned, inspected and lubricated. Headspace 1.502 in. Firing pin protrusion 0.033 in. Firing pin indent 0.022 in. Firing pin diameter 0.060 in. Firing pin hole diameter in bolt 0.063 in. Free length of ejector spring 0.90 in. Free length of extractor spring 0.21 in. Free length of action spring 11.9 in.						
4 March 1968						
0830 to 0832	Steele	100	6300	SAT	958	
0852 to 0854		100	6400	SAT	985	
0918 to 0920		100	6500	SAT	965	Muzzle flash on 1 rd
0947 to 0949		100	6600	SAT	966	
1010 to 1012		100	6700	SAT	938	
The bolt group was removed and lubricated.						
1042 to 1044		100	6800	SAT	983	
1103 to 1105		100	6900	SAT	983	
1123 to 1125		100	7000	SAT	983	
1243 to 1245		100	7100	SAT	954	
1306 to 1308		100	7200	SAT	985	
The bolt group was removed and lubricated. The gas tube was subjected to X-Ray, air flow measurement and weighing. Headspace 1.502 in.						
5 March 1968						
0820 to 0822		100	7300	SAT	972	
0845 to 0847		100	7400	SAT	991	
0909 to 0911		100	7500	SAT	985	
0940 to 0942		100	7600	SAT	987	
1009 to 1011		100	7700	SAT	983	Muzzle flash on 1 rd
The bolt group was removed and lubricated.						
1046 to 1048		100	7800	SAT	996	
1113 to 1115		100	7900	SAT	991	
1130 to 1132		100	8000	SAT	998	
1247 to 1249		100	8100	SAT	1007	
1307 to 1309		100	8200	SAT	1007	
1340 to 1410	Jastrzembski	50	8250	SAT		Accuracy Test

<u>Time</u>	<u>Gunner</u>	<u>Rds</u>	<u>Total Rds</u>	<u>Function</u>	<u>Cyclic Rate (Rds/Min)</u>	<u>Remarks</u>
6 March 1968						
The rifle was disassembled, cleaned, inspected and lubricated.						
Headspace 1.502 in.						
Firing pin protrusion 0.033 in.						
Firing pin indent 0.022 in.						
Firing pin diameter 0.060 in.						
Firing pin hole diameter in bolt 0.063 in.						
Free length of ejector spring 0.90 in.						
Free length of extractor spring 0.21 in.						
Free length of action spring 11.9 in.						
1305 to 1307	Sneade	100	8350	SAT	934	
1328 to 1330		100	8450	SAT	1013	
1355 to 1357		100	8550	SAT	1000	
1418 to 1420		100	8650	SAT	996	
1445 to 1447		100	8750	SAT	970	
The bolt group was removed and lubricated.						
1530 to 1532		100	8850	SAT	996	
1553 to 1555		100	8950	SAT	996	
7 March 1968						
0824 to 0826		100	9050	SAT	972	
0840 to 0842		100	9150	SAT	968	
0900 to 0902		100	9250	SAT	970	
The bolt group was removed and lubricated. The gas tube was subjected to X-Ray, air flow measurement and weighing. Headspace 1.502 in.						
1248 to 1250		100	9350	SAT	989	
1303 to 1305		100	9450	SAT	1002	Breech sparks on 1 rd
1315 to 1318		100	9550	SAT	970	
1339 to 1342		100	9650	2-FJ	965	
1357 to 1405		100	9750	8-FJ	932	
The bolt group was removed and lubricated.						
The extractor spring was broken. It was replaced, Free length of new spring 0.25 in.						
1433 to 1435		100	9850	SAT	981	
1447 to 1449		100	9950	SAT	972	
1508 to 1510		100	10,050	1-FJ	942	
1523 to 1525		100	10,150	SAT	907	
1538 to 1540		100	10,250	SAT	919	

<u>Time</u>	<u>Gunner</u>	<u>Rds</u>	<u>Total Rds</u>	<u>Function</u>	<u>Cyclic Rate (Rds/Min)</u>	<u>Remarks</u>
0855 to 0920	Jastrzemski	50	10,300	SAT		Accuracy Test

8 March 1968
 The rifle was disassembled, cleaned, inspected and lubricated.
 Headspace 1.502 in.
 Firing pin protrusion 0.033 in.
 Firing pin indent 0.023 in.
 Firing pin diameter 0.060 in.
 Firing pin hole diameter in bolt 0.063 in.
 Free length of ejector spring 0.90 in.
 Free length of extractor spring 0.22 in.
 Free length of action spring 11.9 in.

<u>Time</u>	<u>Gunner</u>	<u>Rds</u>	<u>Total Rds</u>	<u>Function</u>	<u>Cyclic Rate (Rds/Min)</u>	<u>Remarks</u>
Rifle, 5.56mm, M16A1, No. 855603 (4)						
Cartridge, 5.56mm, Ball, M193, Lot No. TW18179						
10 January 1968						
The rifle was inspected.						
Headspace 1.501 in.						
Firing pin protrusion 0.034 in.						
Firing pin indent 0.023 in.						
Firing pin diameter 0.060 in.						
Firing pin hole diameter in bolt 0.062 in.						
Free length of ejector spring 0.91 in.						
Free length of extractor spring 0.24 in.						
Free length of action spring 12.1 in.						
Action spring rate 1.57 lbs./in.						
31 January 1968						
1410 to 1450	Jastrzemski	50	50	SAT		Accuracy Test
1 February 1968						
0911 to 0914	Folweiler	100	150	SAT	792	
0937 to 0939		100	250	SAT	797	
1000 to 1002		100	350	SAT	784	
1019 to 1021		100	450	SAT	792	
1044 to 1046		100	550	SAT	800	
The bolt group was removed and lubricated.						
1113 to 1115		100	650	SAT	816	
1134 to 1136		100	750	SAT	800	
1242 to 1244		100	850	SAT	797	
1259 to 1301		100	950	SAT	816	
1316 to 1318		100	1050	SAT	807	
The bolt group was removed and lubricated. The gas tube was removed and subjected to X-Ray, air flow measurement and weighing. Headspace 1.502 in.						
1615 to 1618		100	1150	1-FJ	812	
1633 to 1635		100	1250	SAT	820	
1655 to 1657		100	1350	SAT	819	
1716 to 1718		100	1450	SAT	810	
1738 to 1740		100	1550	SAT	810	
The bolt group was removed and lubricated.						
1828 to 1830		100	1650	SAT	819	
1846 to 1848		100	1750	SAT	795	
1903 to 1905		100	1850	SAT	781	
1921 to 1923		100	1950	SAT	786	
1938 to 1940		100	2050	SAT	792	

<u>Time</u>	<u>Gunner</u>	<u>Rds</u>	<u>Total Rds</u>	<u>Function</u>	<u>Cyclic Rate (Rds/Min)</u>	<u>Remarks</u>
2 February 1968						
The rifle was disassembled, cleaned, inspected and lubricated.						
Headspace 1.502 in.						
Firing pin protrusion 0.034 in.						
Firing pin indent 0.021 in.						
Firing pin diameter 0.060 in.						
Firing pin hole diameter in bolt 0.063 in.						
Free length of ejector spring 0.90 in.						
Free length of extractor spring 0.22 in.						
Free length of action spring 12.1 in.						
The stock was damaged at the points of contact (both sides) with the Springfield Armory firing jack.						
1345 to 1410	Jastrzemski	50	2100	SAT		Accuracy Test
3 February 1968						
0833 to 0835	Steele	100	2200	SAT	819	
0859 to 0901		100	2300	SAT	807	
0917 to 0919		100	2400	SAT	838	
0934 to 0936		100	2500	SAT	820	
0953 to 0955		100	2600	SAT	829	
The bolt group was removed and lubricated.						
1014 to 1016		100	2700	SAT	838	
1033 to 1035		100	2800	SAT	829	
1051 to 1053		100	2900	SAT	826	
1113 to 1115		100	3000	SAT	810	
1131 to 1133		100	3100	SAT	813	
The bolt was removed and lubricated. The gas tube was subjected to X-Ray, air flow measurement and weighing. Headspace 1.502 in.						
1436 to 1438		100	3200	SAT	835	
1452 to 1454		100	3300	SAT	848	
1518 to 1520		100	3400	SAT	819	
1540 to 1542		100	3500	SAT	823	
1610 to 1612		100	3600	SAT	813	
The bolt group was removed and lubricated.						
1735 to 1737		100	3700	SAT	848	
1751 to 1753		100	3800	SAT	844	
1812 to 1814		100	3900	SAT	829	
1833 to 1835		100	4000	SAT	823	
1901 to 1903		100	4100	SAT	810	

<u>Time</u>	<u>Cunner</u>	<u>Rds</u>	<u>Total Rds</u>	<u>Function</u>	<u>Cyclic Rate (Rds/Min)</u>	<u>Remarks</u>
5 February 1968						
0915 to 0946	Jastrzemski	50	4150	SAT		Accuracy Test
The rifle was disassembled, cleaned, inspected and lubricated.						
Headspace 1.502 in.						
Firing pin protrusion 0.034 in.						
Firing pin indent 0.021 in.						
Firing pin diameter 0.060 in.						
Firing pin hole diameter in bolt 0.063 in.						
Free length of ejector spring 0.89 in.						
Free length of extractor spring 0.22 in.						
Free length of action spring 12.1 in.						
6 February 1968						
0851 to 0854	Smeade	100	4250	SAT	823	
0911 to 0914		100	4350	SAT	813	
0940 to 0943		100	4450	SAT	807	
1004 to 1007		100	4550	SAT	816	
1031 to 1033		100	4650	SAT	792	
The bolt group was removed and lubricated.						
1111 to 1113		100	4750	SAT	832	
1130 to 1132		100	4850	SAT	826	
1250 to 1253		100	4950	SAT	800	
1312 to 1314		100	5050	SAT	816	
1405 to 1408		100	5150	SAT	797	
The bolt group was removed and lubricated. The gas tube was subjected to X-Ray, air flow measurement and weighing. Headspace 1.502 in.						
1628 to 1630		100	5250	SAT	838	
1647 to 1649		100	5350	SAT	835	
1711 to 1713		100	5450	SAT	820	
1730 to 1732		100	5550	SAT	823	
1751 to 1753		100	5650	SAT	898	
The bolt group was removed and lubricated. The extractor spring was broken. It was replaced.						
1846 to 1848		100	5750	SAT	800	
1859 to 1901		100	5850	SAT	770	
1921 to 1923		100	5950	SAT	778	
1941 to 1943		100	6050	SAT	797	
1958 to 2000		100	6150	SAT	797	

<u>Time</u>	<u>Gunner</u>	<u>Rds</u>	<u>Total Rds</u>	<u>Function</u>	<u>Cyclic Rate (Rds/Min)</u>	<u>Remarks</u>
7 February 1968						
0908 to 0924	Jastrzemski	50	6200	SAT		Accuracy Test
The rifle was disassembled, cleaned, inspected and lubricated.						
Headspace 1.503 in.						
Firing pin protrusion 0.034 in.						
Firing pin indent 0.022 in.						
Firing pin diameter 0.060 in.						
Firing pin hole diameter in bolt 0.063 in.						
Free length of ejector spring 0.89 in.						
Free length of extractor spring 0.22 in.						
Free length of action spring 12.1 in.						
8 February 1968						
0839 to 0841	Folweiler	100	6300	SAT	841	
0901 to 0903		100	6400	SAT	829	
0920 to 0922		100	6500	SAT	809	The snap ring was lost
and this permitted the ejection port cover pin to disengage at its forward end.						
0954 to 0956		100	6600	SAT	807	
1007 to 1009		100	6700	SAT	813	
The bolt group was removed and lubricated.						
1044 to 1047		100	6800	SAT	828	
1103 to 1105		100	6900	SAT	831	
1120 to 1122		100	7000	SAT	829	
1300 to 1302		100	7100	SAT	816	
1318 to 1320		100	7200	SAT	817	
The bolt group was removed and lubricated. The gas tube was subjected to						
X-Ray, air flow measurement and weighing. Headspace 1.503 in.						
1621 to 1623		100	7300	SAT	829	
1709 to 1711		100	7400	SAT	826	
1725 to 1727		100	7500	SAT	821	
1743 to 1745		100	7600	SAT	800	
1755 to 1757		100	7700	SAT	804	
The bolt group was removed and lubricated.						
1837 to 1839		100	7800	SAT	826	
1854 to 1856		100	7900	SAT	829	
1913 to 1915		100	8000	SAT	825	
1933 to 1935		100	8100	SAT	825	
1953 to 1956		100	8200	SAT	825	

<u>Time</u>	<u>Gunner</u>	<u>Rds</u>	<u>Total Rds</u>	<u>Function</u>	<u>Cyclic Rate (Rds/Min)</u>	<u>Remarks</u>
9 February 1968						
0910 to 0935	Jastrzemski	50	8250	SAT		Accuracy Test
The rifle was disassembled, cleaned, inspected and lubricated.						
Headspace 1.503 in.						
Firing pin, protrusion 0.035 in.						
Firing pin indent 0.022 in.						
Firing pin diameter 0.060 in.						
Firing pin hole diameter in bolt 0.063 in.						
Free length of ejector spring 0.88 in.						
Free length of extractor spring 0.21 in.						
Free length of action spring 12.1 in.						
10 February 1968						
0846 to 0849	Steele	100	8350	SAT	807	
0908 to 0910		100	8450	SAT	813	
0928 to 0930		100	8550	SAT	804	
0947 to 0949		100	8650	SAT	804	
1008 to 1010		100	8750	SAT	823	
The bolt group was removed and lubricated.						
1050 to 1052		100	8850	SAT	851	
1113 to 1115		100	8950	SAT	843	
1133 to 1135		100	9050	SAT	829	
1255 to 1257		100	9150	SAT	810	
1320 to 1322		100	9250	SAT	811	
The bolt group was removed and lubricated. The gas tube was subjected to X-Ray, air flow measurement and weighing. Headspace 1.503 in.						
1623 to 1625		100	9350	SAT	852	
1645 to 1647		100	9450	SAT	848	
1709 to 1911		100	9550	SAT	843	
1730 to 1732		100	9650	SAT	800	
1758 to 1800		100	9750	SAT	785	
The bolt group was removed and lubricated.						
1854 to 1856		100	9850	SAT	834	
1913 to 1930		100	9950	3-FJ	819	Stoppages w/mag. 4B
The rifle was inspected after the third stoppage. The extractor spring was broken. It was replaced. Free length of new extract spring 0.23 in.						
1943 to 1945		100	10,050	SAT	831	
1956 to 1958		100	10,150	SAT	831	
2010 to 2012		100	10,250	SAT	817	

<u>Time</u>	<u>Gunner</u>	<u>Rds</u>	<u>Total Rds</u>	<u>Function</u>	<u>Cyclic Rate (Rds/Min)</u>	<u>Remarks</u>
0922 to 0948	Jastrzemski	50	10,300	SAT		Accuracy Test

12 February 1968

The rifle was disassembled, cleaned, inspected and lubricated.
 Headspace 1.503 in.

Firing pin protrusion 0.035 in.

Firing pin indent 0.024 in.

Firing pin diameter 0.059 in.

Firing pin hole diameter in bolt 0.063 in.

Free length of ejector spring 0.86 in.

Free length of extractor spring 0.21 in.

Free length of action spring 12.0 in.

<u>Time</u>	<u>Gunner</u>	<u>Rds</u>	<u>Total Rds</u>	<u>Function</u>	<u>Cyclic Rate (Rds/Min)</u>	<u>Remarks</u>
Rifle, 5.56mm, M16A1, No. 856133 (5)						
Cartridge, 5.56mm, Ball, M193, Lot No. TW18179						
8 January 1968						
The rifle was inspected.						
Headspace 1.502 in.						
Firing pin protrusion 0.036 in.						
Firing pin indent 0.023 in.						
Firing pin diameter 0.060 in.						
Firing pin hole diameter in bolt 0.063 in.						
Free length of ejector spring 0.92 in.						
Free length of extractor spring 0.24 in.						
Free length of action spring 12.3 in.						
Action spring rate 1.29 lbs/in.						
12 February 1968						
1350 to 1512	Jastrzemski	50	50	SAT		Accuracy Test
13 February 1968						
0855 to 0857	Sneade	100	150	SAT	763	
0917 to 0919		100	250	SAT	802	
0958 to 1000		100	350	SAT	768	
1022 to 1024		100	450	SAT	789	
1045 to 1047		100	550	SAT	797	
The bolt group was removed and lubricated.						
1126 to 1128		100	650	SAT	817	
1138 to 1140		100	750	SAT	800	
1300 to 1302		100	800	SAT	788	
1313 to 1315		100	950	SAT	804	
1326 to 1328		100	1050	SAT	777	
The bolt group was removed and lubricated. The gas tube was removed and subjected to X-Ray, air flow measurement and weighing. Headspace 1.502 in.						
1619 to 1621		100	1150	SAT	832	
1641 to 1643		100	1250	SAT	828	
1705 to 1707		100	1350	SAT	821	
1724 to 1726		100	1450	SAT	800	
1738 to 1740		100	1550	SAT	788	
The bolt group was removed and lubricated.						
1840 to 1842		100	1650	SAT	828	
1854 to 1856		100	1750	SAT	811	
1912 to 1914		100	1850	SAT	799	
1932 to 1934		100	1950	SAT	800	
1950 to 1952		100	2050	SAT	777	

<u>Time</u>	<u>Gunner</u>	<u>Rds</u>	<u>Total Rds</u>	<u>Function</u>	<u>Cyclic Rate (Rds/Min)</u>	<u>Remarks</u>
14 February 1968						
0913 to 0938	Jastrzemski	50	2100	SAT		Accuracy Test
The rifle was disassembled, cleaned, inspected and lubricated.						
Headspace 1.503 in.						
Firing pin protrusion 0.036 in.						
Firing pin indent 0.021 in.						
Firing pin diameter 0.060 in.						
Firing pin hole diameter in bolt 0.063 in.						
Free length of ejector spring 0.91 in.						
Free length of extractor spring 0.24 in.						
Free length of action spring 12.2 in.						
The stock was cracked on the left side at the point of contact with the Springfield Armory firing jack.						
15 February 1968						
0845 to 0847	Folweiler	100	2200	SAT	819	
0908 to 0910		100	2300	SAT	804	
0937 to 0939		100	2400	SAT	774	
0958 to 1000		100	2500	SAT	778	
1020 to 1022		100	2600	SAT	813	
The bolt group was removed and lubricated.						
1100 to 1102		100	2700	SAT	813	
1123 to 1125		100	2800	SAT	804	
1251 to 1253		100	2900	SAT	764	
1316 to 1318		100	3000	SAT	792	
1329 to 1331		100	3100	SAT	804	
The bolt group was removed and lubricated. The gas tube was subjected to X-Ray, air flow measurement and weighing. Headspace 1.503 in.						
1618 to 1620		100	3200	SAT	817	
1638 to 1640		100	3300	SAT	804	
1658 to 1700		100	3400	SAT	784	
1718 to 1720		100	3500	SAT	781	
1739 to 1741		100	3600	SAT	778	
The bolt group was removed and lubricated.						
1841 to 1843		100	3700	SAT	825	
1856 to 1858		100	3800	SAT	820	
1915 to 1917		100	3900	SAT	784	
1935 to 1937		100	4000	SAT	793	
1954 to 1956		100	4100	SAT	804	

<u>Time</u>	<u>Gunner</u>	<u>Rds</u>	<u>Total Rds</u>	<u>Function</u>	<u>Cyclic Rate (Rds/Min)</u>	<u>Remarks</u>
16 February 1968						
0910 to 0935	Jastrzembski	50	4150	SAT		Accuracy Test
The rifle was disassembled, cleaned, inspected and lubricated.						
Headspace 1.503 in.						
Firing pin protrusion 0.036 in.						
Firing pin indent 0.022 in.						
Firing pin diameter 0.060 in.						
Firing pin hole diameter in bolt 0.063 in.						
Free length of ejector spring 0.90 in.						
Free length of extractor spring 0.20 in.						
Free length of action spring 12.2 in.						
17 February 1968						
0834 to 0836	Steele	100	4250	SAT	826	The snap ring was lost
and this permitted the ejection port cover pin to disengage at its forward end.						
0851 to 0853		100	4350	SAT	826	
0912 to 0914		100	4450	SAT	810	
0931 to 0933		100	4550	SAT	828	Magazine 5D was
difficult to insert in and remove from the rifle.						
0954 to 0956		100	4650	SAT	819	
The bolt group was removed and lubricated.						
1041 to 1043		100	4750	SAT	851	
1102 to 1104		100	4850	SAT	840	
1123 to 1125		100	4950	SAT	834	
1257 to 1314		100	5050	2-FJ	810	
The rifle was inspected after the failures to extract. The extractor spring						
was broken. It was replaced. Free length of new spring 0.23 in.						
1325 to 1327		100	5150	SAT	837	
The bolt group was removed and lubricated. The gas tube was subjected to						
X-Ray, air flow measurement and weighing. Headspace 1.503 in. Magazine 5D was						
replaced with 5D1.						
1604 to 1606	Steele	100	5250	SAT	832	
1627 to 1629		100	5350	SAT	864	
1652 to 1654		100	5450	SAT	826	
1718 to 1720		100	5550	SAT	817	
1738 to 1740		100	5650	SAT	832	
The bolt group was removed and lubricated.						
1834 to 1836		100	5750	SAT	867	
1856 to 1858		100	5850	SAT	844	
1918 to 1920		100	5950	SAT	855	
1941 to 1943		100	6050	SAT	806	
1959 to 2001		100	6150	SAT	804	

<u>Time</u>	<u>Gunner</u>	<u>Rds</u>	<u>Total Rds</u>	<u>Function</u>	<u>Cyclic Rate (Rds/Min)</u>	<u>Remarks</u>
19 February 1968						
0910 to 0940	Jastrzemski	50	6200	SAT		Accuracy Test

The rifle was disassembled, cleaned, inspected and lubricated.
 Headspace 1.503 in.
 Firing pin protrusion 0.036 in.
 Firing pin indent 0.021 in.
 Firing pin diameter 0.060 in.
 Firing pin hole diameter in bolt 0.063 in.
 Free length of ejector spring 0.90 in.
 Free length of extractor spring 0.21 in.
 Free length of action spring 12.2 in.
 A new snap ring was installed to retain the ejection port cover pin.

20 February 1968						
0845 to 0847	Sneade	100	6300	SAT	864	Magazines 5A, 5C and 5E were difficult to insert in and remove from the rifle.
0907 to 0909		100	6400	SAT	857	
0929 to 0931		100	6500	SAT	823	
0953 to 0955		100	6600	SAT	796	
1025 to 1027		100	6700	SAT	768	

The bolt group was removed and lubricated.

1119 to 1121		100	6800	SAT	885	
1135 to 1137		100	6900	SAT	862	
1253 to 1255		100	7000	SAT	825	
1312 to 1315		100	7100	SAT	706	
1329 to 1331		100	7200	SAT	756	

The bolt group was removed and lubricated. The gas tube was subjected to X-Ray, air flow measurement and weighing. Headspace 1.504+ in.

1559 to 1602		100	7300	SAT	800	
1627 to 1629		100	7400	SAT	807	
1648 to 1650		100	7500	SAT	838	
1715 to 1717		100	7600	SAT	832	
1735 to 1737		100	7700	SAT	819	

The bolt group was removed and lubricated.

1835 to 1837		100	7800	SAT	864	
1854 to 1856		100	7900	SAT	854	
1917 to 1919		100	8000	SAT	819	
1939 to 1941		100	8100	SAT	823	
1959 to 2008		100	8200	7-FJ	814	

The rifle was inspected after the stoppages. The extractor spring was broken. It was replaced. Free length of new spring 0.26 in.

<u>Time</u>	<u>Gunner</u>	<u>Rds</u>	<u>Total Rds</u>	<u>Function</u>	<u>Cyclic Rate (Rds/Min)</u>	<u>Remarks</u>
21 February 1968						
0925 to 0950	Jastrzemski	50	8250	SAT		Accuracy Test
The rifle was disassembled, cleaned, inspected and lubricated.						
Headspace 1.504+ in.						
Firing pin protrusion 0.037 in.						
Firing pin indent 0.022 in.						
Firing pin diameter 0.060 in.						
Firing pin hole in bolt 0.063 in.						
Free length of ejector spring 0.90 in.						
Free length of extractor spring 0.21 in.						
Free length of action spring 12.2 in.						
23 February 1968						
0845 to 0847	Folweiler	100	8350	SAT	849	
0905 to 0907		100	8450	SAT	835	
0922 to 0924		100	8550	SAT	793	
0943 to 0945		100	8650	SAT	799	
1003 to 1005		100	8750	SAT	816	
The bolt group was removed and lubricated.						
1045 to 1047		100	8850	SAT	843	
1103 to 1105		100	8950	1-FBR	841	Malfunction w/mag. 5D1
1118 to 1120		100	9050	SAT	846	
1249 to 1251		100	9150	SAT	834	
1308 to 1310		100	9250	SAT	797	
The bolt group was removed and lubricated. The gas tube was subjected to X-Ray, air flow measurement and weighing. Headspace 1.504+ in.						
1548 to 1550		100	9350	SAT	825	
1612 to 1614		100	9450	SAT	825	
1634 to 1636		100	9550	SAT	819	
1700 to 1702		100	9650	SAT	826	The snap ring fell off
1730 to 1732		100	9750	SAT	817	
The bolt group was removed and lubricated.						
1842 to 1844		100	9850	SAT	829	
1903 to 1905		100	9950	SAT	829	
1922 to 1924		100	10,050	SAT	826	
1939 to 1941		100	10,150	SAT	781	
1954 to 1956		100	10,250	SAT	796	

<u>Time</u>	<u>Gunner</u>	<u>Rds</u>	<u>Total Rds</u>	<u>Function</u>	<u>Cyclic Rate (Rds/Min)</u>	<u>Remarks</u>
0905 to 0930	Jastrzemski	50	10,300	SAT		Accuracy Test

24 February 1968

The rifle was disassembled, cleaned, inspected and lubricated.
 Headspace 1.504+ in.

Firing pin protrusion 0.036 in.

Firing pin indent 0.021 in.

Firing pin diameter 0.060 in.

Firing pin hole diameter in bolt 0.063 in.

Free length of ejector spring 0.90 in.

Free length of extractor spring 0.19 in.

Free length of action spring 12.2 in.

<u>Time</u>	<u>Gunner</u>	<u>Rds</u>	<u>Total Rds</u>	<u>Function</u>	<u>Cyclic Rate (Rds/Min)</u>	<u>Remarks</u>
Rifle, 5.56mm, M16A1, No. 856760 (6)						
Cartridge, 5.56mm, Ball, M193, Lot No. TW18179						
10 January 1968						
The rifle was inspected.						
Headspace 1.501 in.						
Firing pin protrusion 0.034 in.						
Firing pin indent 0.021 in.						
Firing pin diameter 0.059 in.						
Firing pin hole diameter in bolt 0.063 in.						
Free length of ejector spring 0.91 in.						
Free length of extractor spring 0.22 in.						
Free length of action spring 12.3.						
Action spring rate 1.43 lbs./in.						
24 February 1968						
1325 to 1350	Jastrzemski	50	50	SAT		Accuracy Test
26 February 1968						
0844 to 0846	Steele	100	150	SAT	832	
0905 to 0907		100	250	SAT	880	
0929 to 0931		100	350	SAT	880	
0953 to 0955		100	450	SAT	877	
1016 to 1018		100	550	SAT	864	
The bolt group was removed and lubricated.						
1053 to 1055		100	650	SAT	885	
1116 to 1118		100	750	SAT	854	
1134 to 1136		100	850	1-FBR	854	Malfunction w/mag. 6C
1258 to 1300		100	950	SAT	843	
1319 to 1321		100	1050	SAT	849	
The bolt group was removed and lubricated. The gas tube was subjected to X-Ray, air flow measurement and weighing. Headspace 1.502 in. The stock was cracked on both sides at the points of contact with the Springfield Armory firing jack.						
1608 to 1610		100	1150	SAT	860	
1631 to 1633		100	1250	SAT	859	
1658 to 1700		100	1350	SAT	848	
1724 to 1726		100	1450	1-FBR	840	Malfunction w/mag. 6B
1747 to 1749		100	1550	SAT	835	
The bolt group was removed and lubricated.						
1842 to 1844		100	1650	SAT	857	
1908 to 1910		100	1750	SAT	831	
1931 to 1933		100	1850	SAT	848	
1950 to 1952		100	1950	SAT	859	
2006 to 2008		100	2050	SAT	826	

<u>Time</u>	<u>Gunner</u>	<u>Rds</u>	<u>Total Rds</u>	<u>Function</u>	<u>Cyclic Rate (Rds/Min)</u>	<u>Remarks</u>
27 February 1968						
0910 to 0940	Jastrzemski	50	2100	SAT		Accuracy Test
The rifle was disassembled, cleaned, inspected and lubricated.						
Headspace 1.502 in.						
Firing pin protrusion 0.035 in.						
Firing pin indent 0.023 in.						
Firing pin diameter 0.059 in.						
Firing pin hole diameter in bolt 0.063 in.						
Free length of ejector spring 0.89 in.						
Free length of extractor spring 0.21 in.						
Free length of action spring 12.2 in.						
28 February 1968						
0837 to 0839	Sneade	100	2200	SAT	864	
0903 to 0905		100	2300	SAT	852	
0934 to 0936		100	2400	SAT	826	
1001 to 1003		100	2500	SAT	860	
1023 to 1025		100	2600	SAT	844	
The bolt group was removed and lubricated.						
1058 to 1100		100	2700	SAT	880	
1121 to 1123		100	2800	SAT	864	
1136 to 1138		100	2900	SAT	848	
1250 to 1252		100	3000	SAT	849	
1309 to 1311		100	3100	SAT	841	
The bolt group was removed and lubricated. The gas tube was subjected to X-Ray, air flow measurement and weighing. Headspace 1.502 in.						
1613 to 1615		100	3200	SAT	849	
1637 to 1639		100	3300	SAT	870	
1658 to 1700		100	3400	SAT	840	
1723 to 1725		100	3500	SAT	835	
1745 to 1747		100	3600	SAT	838	
The bolt group was removed and lubricated.						
1840 to 1842		100	3700	SAT	870	
1858 to 1900		100	3800	SAT	865	
1920 to 1922		100	3900	SAT	861	
1936 to 1938		100	4000	SAT	832	
1951 to 1953		100	4100	SAT	829	

<u>Time</u>	<u>Gunner</u>	<u>Rds</u>	<u>Total Rds</u>	<u>Function</u>	<u>Cyclic Rate (Rds/Min)</u>	<u>Remarks</u>
29 February 1968						
0910 to 0935	Jastrzembski	50	4150	SAT		Accuracy Test
The rifle was disassembled, cleaned, inspected and lubricated.						
Headspace 1.502 in.						
Firing pin protrusion 0.035 in.						
Firing pin indent 0.022 in.						
Firing pin diameter 0.059 in.						
Firing pin hole diameter in bolt 0.064 in.						
Free length of ejector spring 0.89 in.						
Free length of extractor spring 0.21 in.						
Free length of action spring 12.2 in.						
1 March 1968						
0843 to 0845	Folweiler	100	4250	SAT	855	
0903 to 0905		100	4350	SAT	879	
0925 to 0927		100	4450	SAT	849	
0950 to 0952		100	4550	SAT	851	
1012 to 1014		100	4650	SAT	852	
The bolt group was removed and lubricated.						
1047 to 1049		100	4750	SAT	894	
1107 to 1109		100	4850	SAT	877	
1123 to 1125		100	4950	SAT	846	
1245 to 1247		100	5050	1-FBR	852	Malfunction w/mag. 6B
1309 to 1311		100	5150	SAT	860	
The bolt group was removed and lubricated. The gas tube was subjected to X-Ray, air flow measurement and weighing. Headspace 1.502 in.						
1615 to 1617		100	5250	SAT	898	
1637 to 1639		100	5350	SAT	859	
1655 to 1657		100	5450	SAT	859	
1723 to 1725		100	5550	SAT	834	
1741 to 1743		100	5650	SAT	831	
The bolt group was removed and lubricated.						
1842 to 1844		100	5750	SAT	874	
1903 to 1905		100	5850	SAT	874	
1922 to 1924		100	5950	SAT	838	
1942 to 1944		100	6050	SAT	826	
2001 to 2003		100	6150	SAT	814	

<u>Time</u>	<u>Gunner</u>	<u>Rds</u>	<u>Total Rds</u>	<u>Function</u>	<u>Cyclic Rate (Rds/Min)</u>	<u>Remarks</u>
2 March 1968						
0906 to 0935	Jastrzemski	50	6200	SAT		Accuracy Test
The rifle was disassembled, cleaned, inspected and lubricated.						
Headspace 1.503 in.						
Firing pin protrusion 0.035 in.						
Firing pin indent 0.022 in.						
Firing pin diameter 0.059 in.						
Firing pin hole diameter in bolt 0.064 in.						
Free length of ejector spring 0.88 in.						
Free length of extractor spring 0.21 in.						
Free length of action spring 12.2 in.						
4 March 1968						
0833 to 0835	Steele	100	6300	SAT	869	
0855 to 0857		100	6400	SAT	852	
0921 to 0923		100	6500	SAT	848	The snap ring was
lost and this	permitted the	ejection port	cover pin to	disengage at its	forward end.	
0950 to 0952		100	6600	SAT	843	
1013 to 1015		100	6700	SAT	841	
The bolt group was removed and lubricated.						
1045 to 1047		100	6800	SAT	891	
1107 to 1109		100	6900	SAT	887	
1126 to 1128		100	7000	SAT	851	
1246 to 1248		100	7100	SAT	843	
1309 to 1311		100	7200	SAT	838	
The bolt group was removed and lubricated. The gas tube was subjected to X-Ray, air flow measurement and weighing. Headspace 1.503 in.						
5 March 1968						
0824 to 0826		100	7300	SAT	846	
0848 to 0850		100	7400	SAT	870	
0912 to 0914		100	7500	SAT	867	
0943 to 0945		100	7600	SAT	855	
1012 to 1014		100	7700	SAT	831	
The bolt group was removed and lubricated.						
Cartridge, 5.56mm, Ball, M193, Lot No. RA5320 (fired inadvertently)						
1052 to 1053		60	7760	SAT		
Cartridge, 5.56mm, Ball, M193, Lot No. TW18179						
1053 to 1054		40	7800	SAT	809	
1116 to 1118		100	7900	SAT	828	
1133 to 1135		100	8000	SAT	829	
1250 to 1252		100	8100	SAT	843	
1310 to 1312		100	8200	SAT	840	
1420 to 1455	Jastrzemski	50	8250	SAT		Accuracy Test

<u>Time</u>	<u>Gunner</u>	<u>Rds</u>	<u>Total Rds</u>	<u>Function</u>	<u>Cyclic Rate (Rds/Min)</u>	<u>Remarks</u>
6 March 1968						
The rifle was disassembled, cleaned, inspected and lubricated.						
Headspace 1.503 in.						
Firing pin protrusion 0.035 in.						
Firing pin indent 0.023 in.						
Firing pin diameter 0.059 in.						
Firing pin hole diameter in bolt 0.064 in.						
Free length of ejector spring 0.88 in.						
Free length of extractor spring 0.20 in.						
Free length of action spring 12.2 in.						
1308 to 1310	Sneade	100	8350	SAT	852	
1330 to 1332		100	8450	SAT	908	
1358 to 1400		100	8550	SAT	864	
1421 to 1423		100	8650	SAT	864	
1448 to 1450		100	8750	SAT	844	
The bolt group was removed and lubricated.						
1533 to 1535		100	8850	SAT	898	
1556 to 1558		100	8950	SAT	877	
7 March 1968						
0826 to 0828		100	9050	SAT	841	
0844 to 0846		100	9150	SAT	855	
0904 to 0906		100	9250	SAT	843	
The bolt group was removed and lubricated. The gas tube was subjected to X-Ray, air flow measurement and weighing. Headspace 1.503 in.						
1251 to 1253		100	9350	SAT	874	
1307 to 1309		100	9450	SAT	828	
1324 to 1326		100	9550	SAT	829	
1343 to 1345		100	9650	SAT	832	
1407 to 1409		100	9750	SAT	799	
The bolt group was removed and lubricated.						
1436 to 1438		100	9850	SAT	851	
1452 to 1454		100	9950	SAT	832	
1511 to 1513		100	10,050	SAT	826	
1526 to 1528		100	10,150	SAT	795	
1541 to 1543		100	10,250	SAT	786	

<u>Time</u>	<u>Gunner</u>	<u>Rds</u>	<u>Total Rds</u>	<u>Function</u>	<u>Cyclic Rate (Rds/Min)</u>	<u>Remarks</u>
0930 to 1000	Jastrzemski	50	10,300	SAT		Accuracy Test

The rifle was disassembled, cleaned, inspected and lubricated.
 Headspace 1.503 in.

Firing pin protrusion 0.034 in.

Firing pin indent 0.023 in.

Firing pin diameter 0.059 in.

Firing pin hole diameter in bolt 0.064 in.

Free length of ejector spring 0.88 in.

Free length of extractor spring 0.20 in.

Free length of action spring 12.2 in.

<u>Time</u>	<u>Gunner</u>	<u>Rds</u>	<u>Total Rds</u>	<u>Function</u>	<u>Cyclic Rate (Rds/Min)</u>	<u>Remarks</u>
Rifle, 5.56mm, M16A1 No. 859129 (7)						
Cartridge, 5.56mm, Ball, M193, Lot No. RA5320						
8 January 1968						
The rifle was inspected.						
Headspace 1.502 in.						
Firing pin protrusion 0.035 in.						
Firing pin indent 0.022 in.						
Firing pin diameter 0.059 in.						
Firing pin hole diameter in bolt 0.063 in.						
Free length of ejector spring 0.91 in.						
Free length of extractor spring 0.24 in.						
Free length of action spring 12.1 in.						
Action spring rate 1.57 lbs./in.						
31 January 1968						
1500 to 1530	Jastrzembski	50	50	SAT		Accuracy Test
1 February 1968						
0915 to 0917	Folweiler	100	150	SAT	870	
0941 to 0943		100	250	SAT	857	
1005 to 1007		100	350	SAT	844	
1031 to 1033		100	450	SAT	829	
1052 to 1054		100	550	SAT	848	
The bolt group was removed and lubricated.						
1117 to 1119		100	650	SAT	867	
1137 to 1139		100	750	SAT	851	
1245 to 1247		100	850	SAT	813	
1304 to 1306		100	950	SAT	816	
1324 to 1326		100	1050	SAT	813	
The bolt group was removed and lubricated. The gas tube was removed and subjected to X-Ray, air flow measurement and weighing. Headspace 1.503 in.						
1623 to 1625		100	1150	SAT	835	
1645 to 1647		100	1250	SAT	835	
1704 to 1706		100	1350	SAT	826	
1722 to 1724		100	1450	SAT	816	
1741 to 1743		100	1550	SAT	810	
The bolt group was removed and lubricated.						
1831 to 1833		100	1650	SAT	832	
1854 to 1856		100	1750	SAT	792	
1911 to 1913		100	1850	SAT	778	
1929 to 1931		100	1950	SAT	760	
1943 to 1945		100	2050	SAT	733	

<u>Time</u>	<u>Gunner</u>	<u>Rds</u>	<u>Total Rds</u>	<u>Function</u>	<u>Cyclic Rate (Rds/Min)</u>	<u>Remarks</u>
2 February 1968						
The rifle was disassembled, cleaned, inspected and lubricated.						
Headspace 1.502 in.						
Firing pin protrusion 0.035 in.						
Firing pin indent 0.018 in.						
Firing pin diameter 0.059 in.						
Firing pin hole diameter in bolt 0.063 in.						
Free length of ejector spring 0.86 in.						
Free length of extractor spring 0.22 in.						
Free length of action spring 12.1 in.						
The stock was damaged at the points of contact (both sides) with the Springfield Armory firing jack.						
1425 to 1455	Jastrzemski	50	2100	SAT		Accuracy Test
3 February 1968						
0836 to 0852	Steele	100	2200	1-FBR 2-FJ	844	Malfunction w/mag. 7A Stoppages w/mag. 7B
The rifle was inspected after the stoppages and it was found that the gas tube retaining pin was missing. The pin was replaced.						
0910 to 0912		100	2300	SAT	832	
0926 to 0928		100	2400	SAT	844	
0944 to 0946		100	2500	SAT	838	
1003 to 1005		100	2600	SAT	807	
The bolt group was removed and lubricated.						
1024 to 1026		100	2700	SAT	819	
1043 to 1045		100	2800	SAT	819	
1104 to 1106		100	2900	SAT	800	
1123 to 1125		100	3000	SAT	789	
1141 to 1143		100	3100	SAT	784	
The bolt group was removed and lubricated. The gas tube was subjected to X-Ray, air flow measurement and weighing. Headspace 1.502 in.						
1439 to 1441		100	3200	SAT	813	
1507 to 1509		100	3300	SAT	795	
1531 to 1533		100	3400	SAT	781	
1600 to 1602		100	3500	SAT	757	
1629 to 1639		99	3599	1-FFR	710	Misfire caused by a lack of a vent hole in case
The bolt group was removed and lubricated.						
1737 to 1739		100	3699	SAT	804	
1804 to 1806		100	3799	SAT	786	
1825 to 1827		100	3899	SAT	763	
1848 to 1850		100	3999	SAT	760	
1916 to 1918		100	4099	SAT	722	

<u>Time</u>	<u>Gunner</u>	<u>Rds</u>	<u>Total Rds</u>	<u>Function</u>	<u>Cyclic Rate (Rds/Min)</u>	<u>Remarks</u>
5 February 1968						
1000 to 1025	Jastrzemski	50	4149	SAT		Accuracy Test
The rifle was disassembled, cleaned, inspected and lubricated.						
Headspace 1.504+ in.						
Firing pin protrusion 0.035 in.						
Firing pin indent 0.021 in.						
Firing pin diameter 0.059 in.						
Firing pin hole diameter in bolt 0.063 in.						
Free length of ejector spring 0.85 in.						
Free length of extractor spring 0.22 in.						
Free length of action spring 12.1 in.						
6 February 1968						
0855 to 0901	Sneade	100	4249	1-FFR	710	Stoppage caused by improper assembly of trigger pin
0930 to 0933		100	4349	SAT	719	
0953 to 0955		100	4449	SAT	726	
1017 to 1020		100	4549	SAT	689	
1042 to 1044		100	4649	SAT	648	
The bolt group was removed and lubricated.						
1114 to 1116		100	4749	SAT	683	
1135 to 1137		100	4849	SAT	679	
1254 to 1257		100	4949	1-FBR	597	Malfunction w/mag. 7A.
1315 to 1355		100	5049	1-FBR		Malfunctions w/mag. 7A.
				2-BOB		
				1-FBR		Malfunctions w/mag. 7B.
				5-BOB		
				1-FBR		Malfunctions w/mag. 7C.
				9-BOB		
				1-FBR		Malfunctions w/mag. 7D.
				10-BOB		
				2-FF		
				1-FBR		Malfunctions w/mag. 7E.
				10-BOB		
				3-FF		
All magazines were replaced.						
1408 to 1432		100	5149	15-FF		Malfunctions w/mag. 7A1
				4-BOB		
				1-FBR		
				12-FF		Malfunctions w/mag. 7B1
				7-BOB		
				1-FBR		
				12-FF		Malfunctions w/mag. 7C1
				7-BOB		
				1-FBR		
				15-FF		Malfunctions w/mag. 7D1
				4-BOB		
				1-FBR		
				8-FF		Malfunctions w/mag. 7E1
				10-BOB		
				1-FBR		

<u>Time</u>	<u>Gunner</u>	<u>Rds</u>	<u>Total Rds</u>	<u>Function</u>	<u>Cyclic Rate (Rds/Min)</u>	<u>Remarks</u>
The bolt group was removed and lubricated. The gas tube was subjected to X-Ray, air flow measurements and weighing. Headspace 1.504+ in.						
The gas tube was replaced.						
1631 to 1637		100	5249	1-BOB	908	Stoppage w/mag. 7C1
1655 to 1657		100	5349	SAT	916	
1717 to 1719		100	5449	SAT	923	
1738 to 1742		100	5549	1-FJ	886	The case ejection pattern was erratic and it is possible that the case catcher interfered with the cases during ejection.
1800 to 1802		100	5649	SAT	912	
The bolt group was removed and lubricated. The ejector spring was replaced. Free length of old spring 0.84 in. Free length of new spring 0.91 in.						
1850 to 1852		100	5749	SAT	901	
1903 to 1905		100	5849	SAT	905	
1924 to 1926		100	5959	SAT	891	
1945 to 1947		100	6049	SAT	894	
2001 to 2003		100	6149	SAT	867	
7 February 1968						
0947 to 1014	Jastrzembski	50	6199	SAT		Accuracy Test
The rifle was disassembled, cleaned, inspected and lubricated. Headspace 1.504+ in.						
Firing pin protrusion 0.035 in.						
Firing pin indent 0.021 in.						
Firing pin diameter 0.059 in.						
Firing pin hole diameter in bolt 0.063 in.						
Free length of ejector spring 0.88 in.						
Free length of extractor spring 0.21 in.						
Free length of action spring 12.1 in.						
8 February 1968						
0843 to 0845	Folweiler	100	6299	SAT	908	
0904 to 0906		100	6399	SAT	884	
0927 to 0929		100	6499	SAT	870	
0958 to 1000		100	6599	SAT	864	The snap ring was lost and this permitted the ejection port cover pin to disengage at its forward end.
1012 to 1014		100	6699	SAT	859	Breech sparks on 2 rds.
The bolt group was removed and lubricated.						
1048 to 1052		100	6799	1-BOB	842	Stoppage w/mag. 7E1.
1111 to 1113		100	6899	SAT	862	
1125 to 1127		100	6999	SAT	862	
1303 to 1305		100	7099	SAT	832	
1325 to 1327		100	7199	SAT	829	
The bolt group was removed and lubricated. The gas tube was subjected to X-Ray, air flow measurement and weighing. Headspace 1504+ in.						
The gas tube retaining pin was missing. It was replaced.						

<u>Time</u>	<u>Gunner</u>	<u>Rds</u>	<u>Total Rds</u>	<u>Function</u>	<u>Cyclic Rate (Rds/Min)</u>	<u>Remarks</u>
1625 to 1627		100	7299	SAT	859	
1711 to 1713		100	7399	SAT	864	Breech sparks on 1 rd.
1728 to 1730		100	7499	SAT	874	
1746 to 1748		100	7599	SAT	843	
1758 to 1800		100	7699	SAT	826	
The bolt group was removed and lubricated.						
1839 to 1841		100	7799	SAT	872	
1857 to 1859		100	7899	SAT	864	
1920 to 1922		100	7999	SAT	838	
1940 to 1942		100	8099	SAT	826	
2001 to 2004		100	8199	SAT	814	
9 February 1968						
0945 to 1010	Jastrzembski	50	8249	SAT		Accuracy Test
The rifle was disassembled, cleaned, inspected and lubricated. The extractor spring was broken. It was replaced. Headspace 1.504+ in. Firing pin protrusion 0.035 in. Firing pin indent 0.021 in. Firing pin diameter 0.059 in. Firing pin hole diameter in bolt 0.063 in. Free length of ejector spring 0.86 in. Free length of extractor spring 0.23 in. Free length of action spring 12.1 in.						
10 February 1968						
0854 to 0858	Steele	100	8349	SAT	821	
0913 to 0915		100	8449	SAT	831	
0932 to 0934		100	8549	SAT	810	
0950 to 0952		100	8649	SAT	792	
1011 to 1013		100	8749	SAT	760	
The bolt group was removed and lubricated.						
1053 to 1055		100	8849	SAT	792	
1117 to 1119		100	8949	SAT	781	
1137 to 1139		100	9049	SAT	770	
1258 to 1300		100	9149	SAT	715	
1324 to 1326		100	9249	SAT	726	
The bolt group was removed and lubricated. The gas tube was subjected to X-Ray, air flow measurement and weighting. Headspace 1.509+ in.						
1626 to 1628		100	9349	SAT	739	
1648 to 1650		100	9449	SAT	749	
1713 to 1715		100	9549	SAT	709	
1738 to 1748		100	9649	2-BOB 1-FFR	541	BOB w/mag. 7C1 & 7E1 FFR w/mag. 7D1. Light indent of firing pin in primer on FFR.

<u>Time</u>	<u>Gunner</u>	<u>Rds</u>	<u>Total Rds</u>	<u>Function</u>	<u>Cyclic Rate (Rds/Min)</u>	<u>Remarks</u>
1800 to 1808		100	9749	5-FF 19-BOB 3-FBR	533	Stoppages w/all mags.
The bolt group was removed and lubricated. The gas tube was replaced.						
1857 to 1900		100	9849	3-FJ	941	Stoppages w/mag. 7B1 & 7E1.
1931 to 1934		100	9949	2-FJ	943	Stoppages w/mag. 7D1 & 7E1.
1946 to 1948		100	10,049	2-FJ	940	Stoppages w/mag. 7B1 & 7E1.
2002 to 2004		100	10,149	1-FJ	921	Stoppage w/mag. 7D1.
2013 to 2015		100	10,249	SAT	929	
1000 to 1028	Jastrzembski	50	10,299	SAT		Accuracy Test
12 February 1968						
The rifle was disassembled, cleaned, inspected and lubricated. The ejector spring was bent and it was binding in the bolt. Headspace 1.504+ in. Firing pin protrusion 0.035 in. Firing pin indent 0.021 in. Firing pin diameter 0.059 in. Firing pin hole diameter in bolt 0.063 in. Free length of ejector spring 0.86 in. Free length of extractor spring 0.21 in. Free length of action spring 12.1 in.						

<u>Time</u>	<u>Gunner</u>	<u>Rds</u>	<u>Total Rds</u>	<u>Function</u>	<u>Cyclic Rate (Rds/Min)</u>	<u>Remarks</u>
Rifle, 5.56mm, M16A1, No. 859908 (8)						
Cartridge, 5.56mm, Ball, M193, Lot No. RA5320						
10 January 1968						
The rifle was inspected.						
Headspace 1.502 in.						
Firing pin protrusion 0.033 in.						
Firing pin indent 0.020 in.						
Firing pin diameter 0.060 in.						
Firing pin hole diameter in bolt 0.063 in.						
Free length of ejector spring 0.92 in.						
Free length of extractor spring 0.24 in.						
Free length of action spring 12.3 in.						
Action spring rate 1.57 lbs./in.						
12 February 1968						
1520 to 1548	Jastrzemski	50	50	SAT		Accuracy Test
13 February 1968						
0859 to 0904	Sneade	100	150	2-BOB	898	Stoppages w/mag. 8B & 8C
0923 to 0925		100	250	SAT	907	
1002 to 1004		100	350	SAT	879	
1026 to 1028		100	450	SAT	896	
1055 to 1057		100	550	SAT	879	
The bolt group was removed and lubricated.						
1128 to 1130		100	650	1-BOB	905	Stoppage w/mag. 8C
1142 to 1144		100	750	SAT	891	
1303 to 1305		100	850	SAT	864	
1316 to 1318		100	950	SAT	865	
1329 to 1331		100	1050	SAT	854	
The bolt group was removed and lubricated. The gas tube was subjected to X-Ray, air flow measurement and weighing. Headspace 1.502 in.						
1623 to 1625		100	1150	SAT	879	
1644 to 1646		100	1250	SAT	875	
1711 to 1713		100	1350	SAT	877	
1728 to 1730		100	1450	SAT	875	
1743 to 1745		100	1550	SAT	848	
The bolt group was removed and lubricated.						
1843 to 1845		100	1650	SAT	891	
1902 to 1904		100	1750	SAT	874	
1921 to 1923		100	1850	SAT	851	
1939 to 1941		100	1950	SAT	860	
1954 to 1956		100	2050	SAT	851	

<u>Time</u>	<u>Gunner</u>	<u>Rds</u>	<u>Total Rds</u>	<u>Function</u>	<u>Cyclic Rate (Rds/Min)</u>	<u>Remarks</u>
14 February 1968						
0953 to 1025	Jastrzemski	50	2100	SAT		Accuracy Test
The rifle was disassembled, cleaned, inspected and lubricated.						
Headspace 1.503 in.						
Firing pin protrusion 0.034 in.						
Firing pin indent 0.023 in.						
Firing pin diameter 0.060 in.						
Firing pin hole diameter in bolt 0.063 in.						
Free length of ejector spring 0.86 in.						
Free length of extractor spring 0.22 in.						
Free length of action spring 12.2 in.						
The stock was cracked on the left side at the point of contact with the Springfield Armory firing jack.						
15 February 1968						
0848 to 0850	Folweiler	100	2200	SAT	870	
0913 to 0915		100	2300	SAT	864	
0942 to 0944		100	2400	SAT	846	
1002 to 1004		100	2500	SAT	843	
1032 to 1034		100	2600	SAT	844	
The bolt group was removed and lubricated.						
1103 to 1105		100	2700	SAT	859	
1126 to 1128		100	2800	SAT	843	
1254 to 1256		100	2900	SAT	826	
1321 to 1323		100	3000	SAT	810	
1332 to 1334		100	3100	SAT	796	
The bolt group was removed and lubricated. The gas tube was subjected to X-Ray, air flow measurement and weighing. Headspace 1.503 in.						
1620 to 1622		100	3200	SAT	831	
1641 to 1643		100	3300	SAT	806	
1702 to 1704		100	3400	SAT	800	
1721 to 1723		100	3500	SAT	796	
1742 to 1744		100	3600	SAT	792	
The bolt group was removed and lubricated.						
1844 to 1846		100	3700	SAT	855	
1859 to 1901		100	3800	SAT	817	
1918 to 1920		100	3900	SAT	806	
1937 to 1939		100	4000	SAT	810	
1957 to 1959		100	4100	SAT	817	

<u>Time</u>	<u>Gunner</u>	<u>Rds</u>	<u>Total Rds</u>	<u>Function</u>	<u>Cyclic Rate (Rds/Min)</u>	<u>Remarks</u>
16 February 1968						
0950 to 1018	Jastrzembski	50	4150	SAT		Accuracy Test
The rifle was disassembled, cleaned, inspected and lubricated.						
Headspace 1.503 in.						
Firing pin protrusion 0.034 in.						
Firing pin indent 0.023 in.						
Firing pin diameter 0.060 in.						
Firing pin hole diameter in bolt 0.063 in.						
Free length of ejector spring 0.86 in.						
Free length of extractor spring 0.22 in.						
Free length of action spring 12.2 in.						
17 February 1968						
0837 to 0839	Steele	100	4250	SAT	869	
0854 to 0856		100	4350	SAT	865	The snap ring was
lost and this permitted the ejection port cover pin to disengage at its forward end.						
0915 to 0917		100	4450	SAT	857	
0936 to 0938		100	4550	SAT	846	
0958 to 1000		100	4650	SAT	819	Magazine 8D was diffi-
cult to insert in and remove from the rifle.						
The bolt group was removed and lubricated.						
1044 to 1046		100	4750	SAT	857	
1107 to 1109		100	4850	SAT	844	
1127 to 1129		100	4950	SAT	826	
1314 to 1317		100	5050	SAT	804	
1328 to 1330		100	5150	SAT	844	
The bolt group was removed and lubricated. The gas tube was subjected to						
X-Ray, air flow measurement and weighing. Headspace 1.502 in. Magazine 8D was						
replaced with 8D1.						
1609 to 1611		100	5250	SAT	840	
1631 to 1633		100	5350	SAT	826	
1656 to 1658		100	5450	SAT	804	
1721 to 1723		100	5550	SAT	763	
1742 to 1744		100	5650	SAT	759	
The bolt group was removed and lubricated.						
1838 to 1840		100	5750	SAT	828	
1859 to 1901		100	5850	1-BOB	791	Stoppage w/mag. 8E
1923 to 1925		100	5950	SAT	796	
1944 to 1946		100	6050	SAT	757	
2002 to 2004		100	6150	SAT	690	

<u>Time</u>	<u>Gunner</u>	<u>Rds</u>	<u>Total Rds</u>	<u>Function</u>	<u>Cyclic Rate (Rds/Min)</u>	<u>Remarks</u>
19 February 1968						
0950 to 1025	Jastrzembki	50	6200	SAT		Accuracy Test
The rifle was disassembled, cleaned, inspected and lubricated.						
Headspace 1.504+ in.						
Firing pin protrusion 0.034 in.						
Firing pin indent 0.023 in.						
Firing pin diameter 0.060 in.						
Firing pin hole diameter in bolt 0.063 in.						
Free length of ejector spring 0.86 in.						
Free length of extractor spring 0.21 in.						
Free length of action spring 12.2 in.						
A new snap ring was installed to retain the ejection port cover pin.						
20 February 1968						
0849 to 0851	Sneade	100	6300	SAT	731	
0911 to 0913		100	6400	2-FF	648	Stoppages w/mag. 8A
0933 to 0940		100	6500	3-FF		Malfunctions w/mag. 8A
				5-BOB		
				1-FS		
				1-FBR		
				3-FF		Malfunctions w/mag. 8B
				2-BOB		
				1-FBR		
				1-FF		Breech sparks on 2 rds
				3-BOB		Malfunctions w/mag. 8C
				1-FBR		
				1-FF		Stoppages w/mag. 8D1
				3-BOB		
				2-BOB	558	Stoppages w/mag. 8E
0957 to 1010		100	6600	14-FF		Malfunctions w/mag. 8A
				5-BOB		
				1-FBR		
				11-FF		Malfunctions w/mag. 8B
				5-BOB		
				1-FBR		
				17-FF		Malfunctions w/mag. 8C
				1-BOB		
				1-FBR		
				10-FF		Malfunctions w/mag. 8D1
				5-BOB		
				1-FBR		
				15-FF		Malfunctions w/mag. 8E
				2-BOB		
				1-FBR		

<u>Time</u>	<u>Gunner</u>	<u>Rds</u>	<u>Total Rds</u>	<u>Function</u>	<u>Cyclic Rate (Rds/Min)</u>	<u>Remarks</u>
1028 to 1041		100	6700	12-FF 7-FJ 1-FBR		Malfunctions w/mag. 8A
				13-FF 6-FJ 1-FBR		Malfunctions w/mag. 8B
				10-FF 9-FJ 1-FBR		Malfunctions w/mag. 8C
				10-FF 9-FJ 1-FBR		Malfunctions w/mag. 8D1
				5-FF 14-FJ 1-FBR		Malfunctions w/mag. 8E
The bolt group was removed and lubricated. The gas tube was replaced.						
1122 to 1125		100	6800	3-FJ	1023	Stoppages w/mag. 8B, 8C, and 8E
1138 to 1140		100	6900	SAT	1022	
1257 to 1259		100	7000	SAT	998	Magazines 8A and 8E
were difficult to insert in and remove from the rifle.						
1319 to 1321		100	7100	SAT	950	
1332 to 1334		100	7200	1-FJ	967	Stoppage w/mag. 8E
The bolt group was removed and lubricated. The gas tube was subjected to X-Ray, air flow measurement and weighing. Headspace 1.504+ in.						
1607 to 1610		100	7300	SAT	991	
1630 to 1632		100	7400	SAT	996	
1651 to 1653		100	7500	SAT	1009	
1718 to 1720		100	7600	SAT	1009	
1739 to 1741		100	7700	SAT	983	
The bolt group was removed and lubricated.						
1838 to 1840		100	7800	1-FJ	1003	Stoppage w/mag. 8E
1900 to 1903		100	7900	2-FJ	973	Stoppages w/mag. 8C and 8E
1927 to 1929		100	8000	SAT	1002	
1949 to 1951		100	8100	SAT	974	
2009 to 2011		100	8200	SAT	942	
21 February 1968						
1000 to 1030	Jastrzemski	50	8250	SAT		Accuracy Test

The rifle was disassembled, cleaned, inspected and lubricated.
 Headspace 1.504+ in.
 Firing pin protrusion 0.034 in.
 Firing pin indent 0.022 in.
 Firing pin diameter 0.060 in.
 Firing pin hole diameter in bolt 0.063 in.
 Free length of ejector spring 0.85 in.
 Free length of extractor spring 0.21 in.
 Free length of action spring 12.2 in.

<u>Time</u>	<u>Gunner</u>	<u>Rds</u>	<u>Total Rds</u>	<u>Function</u>	<u>Cyclic Rate (Rds/Min)</u>	<u>Remarks</u>
23 February 1968						
0848 to 0850	Folweiler	100	8350	SAT	970	
0908 to 0910		100	8450	SAT	972	
0925 to 0927		100	8550	SAT	968	
0946 to 0948		100	8650	SAT	989	
1005 to 1007		100	8750	SAT	1002	
The bolt group was removed and lubricated. The extractor spring was broken. It was replaced. Free length of new spring 0.26 in.						
1047 to 1049		100	8850	1-FJ	1002	Stoppage w/mag. 8D1
1107 to 1109		100	8950	SAT	1011	
1125 to 1127		100	9050	SAT	1011	Breech sparks on 1 rd
1252 to 1254		100	9150	SAT	950	Muzzle flash on 1 rd
1310 to 1312		100	9250	1-FJ	932	Stoppage w/mag. 8E
The bolt group was removed and lubricated. The gas tube was subjected to X-Ray, air flow measurement and weighing. Headspace 1.504+ in.						
1551 to 1553		100	9350	SAT	962	
1615 to 1617		100	9450	SAT	931	
1637 to 1639		100	9550	SAT	910	
1704 to 1706		100	9650	SAT	907	
1733 to 1735		100	9750	SAT	880	
The bolt group was removed and lubricated.						
1845 to 1847		100	9850	SAT	933	
1906 to 1908		100	9950	SAT	934	
1925 to 1927		100	10,050	SAT	857	
1942 to 1944		100	10,150	SAT	864	
1958 to 2000		100	10,250	1-FBR	838	Malfunction w/mag.8A
24 February 1968						
0945 to 1010	Jastrzembski	50	10,300	SAT		Accuracy Test
The rifle was disassembled, cleaned, inspected and lubricated. Headspace 1.504+ in.						
Firing pin protrusion 0.033 in.						
Firing pin indent 0.022 in.						
Firing pin diameter 0.060 in.						
Firing pin hole diameter in bolt 0.063 in.						
Free length of ejector spring 0.85 in.						
Free length of extractor spring 0.20 in.						
Free length of action spring 12.2 in.						

<u>Time</u>	<u>Gunner</u>	<u>Rds</u>	<u>Total Rds</u>	<u>Function</u>	<u>Cyclic Rate (Rds/Min)</u>	<u>Remarks</u>
Rifle, 5.56mm, M16A1, No. 861015 (9)						
Cartridge, 5.56mm, Ball, M193, Lot No. RA5320						
9 January 1968						
The rifle was inspected.						
Headspace 1.502 in.						
Firing pin protrusion 0.034 in.						
Firing pin indent 0.021 in.						
Firing pin diameter 0.061 in.						
Firing pin hole diameter in bolt 0.063 in.						
Free length of ejector spring 0.91 in.						
Free length of extractor spring 0.23 in.						
Free length of action spring 12.2 in.						
Action spring rate 1.36 lbs./in.						
24 February 1968						
1400 to 1427	Jastrzemski	50	50	SAT		Accuracy Test
26 February 1968						
0847 to 0849	Steele	100	150	SAT	865	
0908 to 0910		100	250	SAT	891	
0932 to 0934		100	350	SAT	880	
0956 to 1958		100	450	SAT	857	
1019 to 1021		100	550	SAT	837	Breech sparks on 1 rd
The bolt group was removed and lubricated.						
1057 to 1059		100	650	SAT	879	
1119 to 1121		100	750	SAT	848	
1138 to 1140		100	850	SAT	841	
1301 to 1303		100	950	SAT	814	Breech sparks on 1 rd
1322 to 1324		100	1050	SAT	817	Breech sparks on 1 rd
The bolt group was removed and lubricated. The gas tube was subjected to X-Ray, air flow measurement and weighing. Headspace 1.503 in.						
1611 to 1613		100	1150	SAT	851	
1635 to 1637		100	1250	SAT	829	
1701 to 1703		100	1350	SAT	826	
1728 to 1730		100	1450	SAT	817	
1750 to 1752		100	1550	SAT	807	Breech sparks on 1 rd
The bolt group was disassembled and lubricated.						
1841 to 1848		100	1650	SAT	825	
1912 to 1914		100	1750	SAT	793	
1934 to 1936		100	1850	SAT	797	
1953 to 1955		100	1950	SAT	816	
2009 to 2011		100	2050	SAT	790	

<u>Time</u>	<u>Gunner</u>	<u>Rds</u>	<u>Total Rds</u>	<u>Function</u>	<u>Cyclic Rate (Rds/Min)</u>	<u>Remarks</u>
27 February 1968						
0955 to 1020	Jastrzemski	50	2100	SAT		Accuracy Test
The rifle was disassembled, cleaned, inspected and lubricated.						
Headspace 1.504+ in.						
Firing pin protrusion 0.035 in.						
Firing pin indent 0.022 in.						
Firing pin diameter 0.061 in.						
Firing pin hole diameter in bolt 0.063 in.						
Free length of ejector spring 0.87 in.						
Free length of extractor spring 0.21 in.						
Free length of action spring 12.2 in.						
28 February 1968						
0839 to 0841	Sneade	100	2200	SAT	813	
0906 to 0908		100	2300	SAT	778	
0937 to 0939		100	2400	SAT	763	
1004 to 1006		100	2500	SAT	744	
1026 to 1028		100	2600	SAT	714	
The bolt group was disassembled and lubricated.						
1100 to 1102		100	2700	SAT	792	
1123 to 1125		100	2800	SAT	785	
1140 to 1142		100	2900	SAT	731	
1253 to 1255		100	3000	SAT	733	
1312 to 1314		100	3100	SAT	723	
The bolt group was removed and lubricated. The gas tube was subjected to X-Ray, air flow measurement and weighing. Headspace 1.054+ in.						
1615 to 1617		100	3200	SAT	788	
1640 to 1642		100	3300	SAT	778	
1708 to 1710		100	3400	SAT	751	
1732 to 1734		100	3500	SAT	731	
1747 to 1749		100	3600	SAT	662	
The bolt group was removed and lubricated.						
1843 to 1845		100	3700	SAT	733	
1903 to 1905		100	3800	SAT	740	
1923 to 1925		100	3900	SAT	704	
1939 to 1941		100	4000	SAT	650	
1955 to 1957		100	4100	SAT	610	

<u>Time</u>	<u>Gunner</u>	<u>Rds</u>	<u>Total Rds</u>	<u>Function</u>	<u>Cyclic Rate (Rds/Min)</u>	<u>Remarks</u>
29 February 1968						
0950 to 1015	Jastrzemski	50	4150	SAT		Accuracy Test
The rifle was disassembled, cleaned, inspected and lubricated.						
Headspace 1.504+ in.						
Firing pin protrusion 0.034 in.						
Firing pin indent 0.020 in.						
Firing pin diameter 0.061 in.						
Firing pin hole diameter in bolt 0.063 in.						
Free length of ejector spring 0.86 in.						
Free length of extractor spring 0.21 in.						
Free length of action spring 12.2 in.						
1 March 1968						
0845 to 0847	Folweiler	100	4250	SAT	725	
0907 to 0909		100	4350	SAT	713	
0929 to 0931		100	4450	SAT	722	
0953 to 0955		100	4550	SAT	708	
1016 to 1020		100	4650	2-BOB 1-FF	648	BOBs with mag. 9A FF with mag. 9B
The bolt group was removed and lubricated.						
1050 to 1052		100	4750	SAT	738	
1106 to 1108		100	4850	1-BOB	725	Stoppages w/mag. 9A
1127 to 1130		100	4950	3-BOB 1-FF 1-FBR 1-FF 1-FBR 1-BOB	620	Stoppages w/mag. 9A Stoppages w/ mag. 9B
1248 to 1252		100	5050	6-BOB 3-FF 1-FBR 4-BOB 1-FBR 1-FBR 3-BOB 2-FF	581	Stoppage w/mag. 9C Stoppages w/mag. 9A Stoppages w/mag. 9B Malfunction w/mag. 9C Stoppages w/mag. 9D
1315 to 1323		100	5150	7-BOB 10-FF 1-FBR 5-BOB 10-FF 1-FBR 6-BOB 13-FF 1-FBR		Stoppages w/mag. 9A Stoppages w/mag. 9B Stoppages w/mag. 9C

<u>Time</u>	<u>Gunner</u>	<u>Rds</u>	<u>Total Rds</u>	<u>Function</u>	<u>Cyclic Rate (Rds/Min)</u>	<u>Remarks</u>
				6-BOB		Stoppages w/mag. 9D
				10-FF		
				1-FBR		
				6-BOB		Stoppages w/mag. 9E
				8-FF		
				1-FBR		
The bolt group was removed and lubricated. The gas tube was subjected to X-Ray, air flow measurement and weighing. Headspace 1.504+ in. The gas tube was replaced.						
1618 to 1620		100	5250	SAT	903	
1641 to 1643		100	5350	SAT	912	
1707 to 1709		100	5450	SAT	894	
1730 to 1732		100	5550	SAT	870	
1748 to 1750		100	5650	SAT	894	
The bolt group was removed and lubricated.						
1845 to 1847		100	5750	SAT	898	
1906 to 1908		100	5850	SAT	887	
1925 to 1927		100	5950	SAT	849	
1945 to 1947		100	6050	SAT	817	
2004 to 2006		100	6150	SAT	831	
2 March 1968						
0948 to 1015	Jastrzembski	50	6200	SAT		Accuracy Test
The rifle was disassembled, cleaned, inspected and lubricated. Headspace 1.504+ in. Firing pin protrusion 0.034 in. Firing pin indent 0.020 in. Firing pin diameter 0.061 in. Firing pin hole diameter in bolt 0.063 in. Free length of ejector spring 0.86 in. Free length of extractor spring 0.21 in. Free length of action spring 12.2 in.						
4 March 1968						
0836 to 0838	Steele	100	6300	SAT	882	
0858 to 0900		100	6400	SAT	860	
0925 to 0928		100	6500	1-FS*	819	*1st rd from mag. 9E
0953 to 0955		100	6600	1-FS*	813	*1st rd from mag. 9E
1015 to 1017		100	6700	SAT	838	
The bolt group was removed and lubricated.						
1048 to 1050		100	6800	SAT	875	
1110 to 1112		100	6900	SAT	852	
1129 to 1131		100	7000	1-FS*	821	*1st rd from mag. 9E
1149 to 1151		100	7100	SAT	819	
1312 to 1314		100	7200	SAT	797	
Magazine 9E was replaced with 9E1.						

<u>Time</u>	<u>Gunner</u>	<u>Rds</u>	<u>Total Rds</u>	<u>Function</u>	<u>Cyclic Rate (Rds/Min)</u>	<u>Remark</u>
The bolt group was removed and lubricated. The gas tube was subjected to X-Ray, air flow measurement and weighing. Headspace 1.504+ in.						
5 March 1968						
0827 to 0829		100	7300	SAT	877	
0851 to 0853		100	7400	SAT	860	
0915 to 0917		100	7500	SAT	862	
0946 to 0948		100	7600	SAT	841	
1015 to 1017		100	7700	SAT	806	
The bolt group was removed and lubricated.						
Cartridge, 5.56mm, Ball, M193, Lot TW18179 (fired inadvertently)						
1049 to 1051		100	7800	SAT	740	
Cartridge, 5.56mm, Ball, M193, Lot RA5320						
1119 to 1121		100	7900	SAT	832	
1136 to 1138		100	8000	SAT	831	
1253 to 1255		100	8100	SAT	823	
1314 to 1316		100	8200	SAT	848	
1505 to 1530	Jastrzemski	50	8250	SAT		Accuracy Test
6 March 1968						
The rifle was disassembled, cleaned, inspected and lubricated. Headspace 1.504+ in.						
Firing pin protrusion 0.034 in.						
Firing pin indent 0.020 in.						
Firing pin diameter 0.061 in.						
Firing pin hole diameter in bolt 0.063 in.						
Free length of ejector spring 0.86 in.						
Free length of extractor spring 0.20 in.						
Free length of action spring 12.2 in.						
1310 to 1312	Sneade	100	8350	SAT	869	The snap ring was lost and this permitted the ejection port cover pin to disengage at its forward end. The pin and cover were removed from the rifle.
1333 to 1335		100	8450	SAT	927	Mag. 9D was difficult to insert in and remove from the rifle.
1401 to 1403		100	8550	SAT	901	
1431 to 1433		100	8650	SAT	923	
1500 to 1502		100	8750	SAT	882	
The bolt group was removed and lubricated. Magazine 9D was replaced with 9D1.						
1535 to 1537		100	8850	SAT	907	
1558 to 1600		100	8950	SAT	870	
7 March 1968						
0829 to 0831		100	9050	SAT	857	
0848 to 0850		100	9150	SAT	841	
0909 to 0911		100	9250	SAT	817	

<u>Time</u>	<u>Gunner</u>	<u>Rds</u>	<u>Total Rds</u>	<u>Function</u>	<u>Cyclic Rate (Rds/Min)</u>	<u>Remarks</u>
The bolt group was removed and lubricated. The gas tube was subjected to X-Ray, air flow measurement and weighing. Headspace 1.504+ in.						
1254 to 1256		100	9350	SAT	887	
1310 to 1312		100	9450	SAT	884	
Firing was discontinued because of exhaustion of the ammunition supply.						

8 March 1968

The rifle was disassembled, cleaned, inspected and lubricated.
 Headspace 1.504+ in.
 Firing pin protrusion 0.034 in.
 Firing pin indent 0.022 in.
 Firing pin diameter 0.061 in.
 Firing pin hole diameter in bolt 0.063 in.
 Free length of ejector spring 0.85 in.
 Free length of extractor spring 0.20 in.
 Free length of action spring 12.1 in.

<u>Time</u>	<u>Gunner</u>	<u>Rds</u>	<u>Total Rds</u>	<u>Function</u>	<u>Cyclic Rate (Rds/Min)</u>	<u>Remarks</u>
Rifle, 5.56mm, M16A1, No. 862235 (10)						
Cartridge, 5.56mm, Ball, M193, Lot No. TW18191						
8 January 1968						
The rifle was inspected.						
Headspace 1.501 in.						
Firing pin protrusion 0.032 in.						
Firing pin indent 0.022 in.						
Firing pin diameter 0.060 in.						
Firing pin hole diameter in bolt 0.063 in.						
Free length of ejector spring 0.92 in.						
Free length of extractor spring 0.24 in.						
Free length of action spring 12.1 in.						
Action spring rate 1.29 lbs./in.						
31 January 1968						
1542 to 1610	Jastrzembski	50	50	SAT		Accuracy Test
1 February 1968						
0918 to 0920	Folweiler	100	150	SAT	751	
0946 to 0948		100	250	SAT	735	
1013 to 1015		100	350	SAT	739	
1038 to 1040		100	450	SAT	713	
1056 to 1058		100	550	SAT	731	
The bolt group was removed and lubricated.						
1123 to 1125		100	650	SAT	735	
1145 to 1147		100	750	SAT	713	
1247 to 1249		100	850	SAT	675	
1307 to 1309		100	950	SAT	691	
1331 to 1333		100	1050	SAT	683	
The bolt group was removed and lubricated. The gas tube was removed and subjected to X-Ray, air flow measurement and weighing. Head space 1.501 in.						
1626 to 1628		100	1150	SAT	691	
1648 to 1650		100	1250	SAT	585	
1708 to 1710		100	1350	SAT	685	
1732 to 1734		100	1450	SAT	671	
1749 to 1751		100	1550	SAT	704	
The bolt group was removed and lubricated.						
1833 to 1835		100	1650	SAT	717	
1857 to 1859		100	1750	SAT	706	
1914 to 1916		100	1850	1-FBR	667	Malfunction w/mag. 10A.
1932 to 1934		100	1950	SAT	640	
1946 to 1948		100	2050	SAT	685	

<u>Time</u>	<u>Gunner</u>	<u>Rds</u>	<u>Total Rds</u>	<u>Function</u>	<u>Cyclic Rate (Rds/Min)</u>	<u>Remarks</u>
2 February 1968						
The rifle was disassembled, cleaned, inspected and lubricated.						
Headspace 1.502 in.						
Firing pin protrusion 0.033 in.						
Firing pin indent 0.022 in.						
Firing pin diameter 0.060 in.						
Firing pin hole diameter in bolt 0.063 in.						
Free length of ejector spring 0.91 in.						
Free length of extractor spring 0.22 in.						
Free length of action spring 12.2 in.						
The stock was damaged at the points of contact (both sides) with the Springfield Armory firing jack.						
1507 to 1535	Jastrzemski	50	2100	SAT		Accuracy Test
3 February 1968						
0853 to 0855	Steele	100	2200	SAT	765	
0912 to 0914		100	2300	SAT	751	
0929 to 0931		100	2400	SAT	751	
0947 to 0949		100	2500	SAT	749	
1005 to 1007		100	2600	SAT	749	
The bolt group was disassembled and lubricated.						
1028 to 1030		100	2700	SAT	775	
1046 to 1048		100	2800	SAT	754	
1107 to 1109		100	2900	SAT	749	
1126 to 1128		100	3000	SAT	746	
1144 to 1146		100	3100	SAT	746	
The bolt group was removed and lubricated. The gas tube was removed and subjected to X-Ray, air flow measurement and weighting. Headspace 1.502 in.						
1442 to 1444		100	3200	SAT	757	
1510 to 1512		100	3300	SAT	739	
1533 to 1535		100	3400	SAT	741	
1603 to 1605		100	3500	SAT	733	
1640 to 1642		100	3600	SAT	731	
The bolt group was disassembled and lubricated.						
1741 to 1743		100	3700	SAT	756	
1807 to 1809		100	3800	SAT	744	
1827 to 1829		100	3900	SAT	760	
1850 to 1853		100	4000	SAT	741	
1919 to 1921		100	4100	SAT	739	

<u>Time</u>	<u>Gunner</u>	<u>Rds</u>	<u>Total Rds</u>	<u>Function</u>	<u>Cyclic Rate (Rds/Min)</u>	<u>Remarks</u>
5 February 1968						
1038 to 1109	Jastrzemski	50	4150	SAT		Accuracy Test
The rifle was disassembled, cleaned, inspected and lubricated.						
Headspace 1.502 in.						
Firing pin protrusion 0.034 in.						
Firing pin indent 0.022 in.						
Firing pin diameter 0.060 in.						
Firing pin hole diameter in bolt 0.063 in.						
Free length of ejector spring 0.91 in.						
Free length of extractor spring 0.22 in.						
Free length of action spring 12.1 in.						
6 February 1968						
0903 to 0906	Sneade	100	4250	SAT	766	
0934 to 0936		100	4350	SAT	775	
0975 to 0959		100	4450	SAT	751	
1021 to 1023		100	4550	SAT	757	
1045 to 1047		100	4650	SAT	737	
The bolt group was removed and lubricated.						
1117 to 1119		100	4750	SAT	746	
1138 to 1141		100	4850	SAT	744	
1258 to 1300		100	4950	SAT	710	
1358 to 1400		100	5050	SAT	722	
1433 to 1435		100	5150	SAT	717	
The bolt group was removed and lubricated. The gas tube was subjected to X-Ray, air flow measurement and weighing. Headspace 1.502 in.						
1639 to 1641		100	5250	SAT	749	
1658 to 1701		100	5350	SAT	763	
1721 to 1723		100	5450	SAT	756	
1743 to 1745		100	5550	SAT	724	
1804 to 1806		100	5650	SAT	733	
The bolt group was removed and lubricated.						
1853 to 1855		100	5750	SAT	781	
1906 to 1908		100	5850	SAT	760	
1927 to 1929		100	5950	SAT	746	
1948 to 1950		100	6050	SAT	757	
2004 to 2006		100	6150	SAT	744	

<u>Time</u>	<u>Gunner</u>	<u>Rds</u>	<u>Total Rds</u>	<u>Function</u>	<u>Cyclic Rate (Rds/Min)</u>	<u>Remarks</u>
7 February 1968						
1025 to 1048	Jastrzemski	50	6200	SAT		Accuracy Test
The rifle was disassembled, cleaned, inspected and lubricated. Headspace 1.502 in. Firing pin protrusion 0.034 in. Firing pin indent 0.020 in. Firing pin diameter 0.060 in. Firing pin hole diameter in bolt 0.063 in. Free length of ejector spring 0.90 in. Free length of extractor spring 0.21 in. Free length of action spring 12.1 in.						
8 February 1968						
0846 to 0848	Folweiler	100	6300	SAT	778	
0909 to 0911		100	6400	SAT	750	
0940 to 0942		100	6500	SAT	744	
1001 to 1003		100	6600	SAT	725	
1021 to 1023		100	6700	SAT	733	
The bolt group was removed and lubricated.						
1053 to 1055		100	6800	SAT	774	
1114 to 1116		100	6900	SAT	773	
1132 to 1134		100	7000	SAT	755	
1304 to 1306		100	7100	SAT	732	
1327 to 1329		100	7200	SAT	752	
The bolt group was removed and lubricated. The gas tube was subjected to X-Ray, air flow measurement and weighing. Headspace 1.502 in.						
1627 to 1629		100	7300	SAT	759	
1713 to 1715		100	7400	SAT	777	
1731 to 1733		100	7500	SAT	797	
1749 to 1751		100	7600	SAT	759	
1801 to 1802		100	7700	SAT	743	
The bolt group was removed and lubricated.						
1843 to 1845		100	7800	SAT	788	
1900 to 1903		100	7900	SAT	784	
1923 to 1925		100	8000	SAT	792	
1943 to 1945		100	8100	SAT	790	
2005 to 2007		100	8200	SAT	788	

<u>Time</u>	<u>Gunner</u>	<u>Rds</u>	<u>Total Rds</u>	<u>Function</u>	<u>Cyclic Rate (Rds/Min)</u>	<u>Remarks</u>
9 February 1968						
1025 to 1045	Jastrzembski	50	8250	SAT		Accuracy Test
The rifle was disassembled, cleaned, inspected and lubricated.						
Headspace 1.504 in.						
Firing pin protrusion 0.035 in.						
Firing pin indent 0.023 in.						
Firing pin diameter 0.060 in.						
Firing pin hole diameter in bolt 0.063 in.						
Free length of ejector spring 0.90 in.						
Free length of extractor spring 0.22 in.						
Free length of action spring 12.1 in.						
10 February 1968						
0857 to 0859	Steele	100	8350	SAT	817	
0916 to 0918		100	8450	SAT	797	
0935 to 0938		100	8550	SAT	779	
0953 to 0955		100	8650	SAT	756	
1014 to 1016		100	8750	SAT	737	
The bolt group was removed and lubricated.						
1056 to 1058		100	8850	SAT	788	
1120 to 1122		100	8950	SAT	778	
1140 to 1143		100	9050	SAT	755	
1302 to 1304		100	9150	SAT	725	
1327 to 1329		100	9250	SAT	743	
The bolt group was removed and lubricated. The gas tube was subjected to X-Ray, air flow measurement and weighing. Headspace 1.502 in.						
1630 to 1632		100	9350	SAT	785	
1651 to 1653		100	9450	SAT	769	
1717 to 1719		100	9550	SAT	764	
1750 to 1752		100	9650	SAT	723	
1809 to 1811		100	9750	SAT	740	
The bolt group was removed and lubricated.						
1902 to 1904		100	9850	SAT	788	
1935 to 1937		100	9950	SAT	763	
1948 to 1950		100	10,050	SAT	754	
2005 to 2007		100	10,150	SAT	737	
2016 to 2018		100	10,250	SAT	754	

<u>Time</u>	<u>Gunner</u>	<u>Rds</u>	<u>Total Rds</u>	<u>Function</u>	<u>Cyclic Rate (Rds/Min)</u>	<u>Remarks</u>
1040 to 1108	Jastrzemski	50	10,300	SAT		Accuracy Test

12 February 1968

The rifle was disassembled, cleaned, inspected and lubricated.
 Headspace 1.502+ in.

Firing pin protrusion 0.034 in.

Firing pin indent 0.022 in.

Firing pin diameter 0.060 in.

Firing pin hole diameter in bolt 0.063 in.

Free length of ejector spring 0.90 in.

Free length of extractor spring 0.21 in.

Free length of action spring 12.1 in.

Time	Gunner	Rds	Total Rds	Function	Cyclic Rate (Rds/Min)	Remarks
Rifle, 5.56mm, M16A1, No. 863323 (11)						
Cartridge, 5.56mm, Ball, M193, Lot No. TW18191						
8 January 1968						
The rifle was inspected.						
Headspace 1.502 in.						
Firing pin protrusion 0.034 in.						
Firing pin indent 0.023 in.						
Firing pin diameter 0.060 in.						
Firing pin hole diameter in bolt 0.063 in.						
Free length of ejector spring 0.91 in.						
Free length of extractor spring 0.24 in.						
Free length of action spring 12.2 in.						
Action spring rate 1.57 lbs./in.						
12 February 1968						
1600 to 1630	Jastrzemski	50	50	SAT		Accuracy Test
13 February 1968						
0906 to 0908	Sneade	100	150	SAT	744	
0945 to 0947		100	250	SAT	750	
1013 to 1015		100	350	SAT	737	
1038 to 1040		100	450	SAT	717	
1104 to 1106		100	550	SAT	683	
The bolt group was removed and lubricated. The stock was cracked on the left side at the point of contact with the Springfield Armory firing jack.						
1131 to 1133		100	650	SAT	700	
1145 to 1147		100	750	SAT	689	
1307 to 1309		100	850	SAT	663	
1319 to 1321		100	950	SAT	692	
1331 to 1333		100	1050	SAT	659	
The bolt group was removed and lubricated. The gas tube was subjected to X-Ray, air flow measurement and weighing. Headspace 1.502 in. The gas tube retaining pin was loose. It was replaced.						
1626 to 1628		100	1150	SAT	738	
1647 to 1649		100	1250	SAT	707	
1714 to 1716		100	1350	SAT	688	
1731 to 1733		100	1450	SAT	723	
1746 to 1748		100	1550	SAT	679	
The bolt group was removed and lubricated.						
1846 to 1848		100	1650	SAT	750	1 Split case
1906 to 1908		100	1750	SAT	685	
1925 to 1927		100	1850	SAT	696	
1943 to 1945		100	1950	SAT	680	
1957 to 1959		100	2050	SAT	689	

<u>Time</u>	<u>Gunner</u>	<u>Rds</u>	<u>Total Rds</u>	<u>Function</u>	<u>Cyclic Rate (Rds/Min)</u>	<u>Remarks</u>
14 February 1968						
1037 to 1103	Jastrzemski	50	2100	SAT		Accuracy Test
The rifle was disassembled, cleaned, inspected and lubricated.						
Headspace 1.502 in.						
Firing pin protrusion 0.034 in.						
Firing pin indent 0.021 in.						
Firing pin diameter 0.060 in.						
Firing pin hole diameter in bolt 0.063 in.						
Free length of ejector spring 0.89 in.						
Free length of extractor spring 0.23 in.						
Free length of action spring 12.1 in.						
15 February 1968						
0851 to 0853	Folweiler	100	2200	SAT	708	Mag. 11C was difficult to assemble in and remove from the rifle.
0916 to 0918		100	2300	SAT	755	
0947 to 0949		100	2400	SAT	723	
1009 to 1011		100	2500	SAT	693	
1035 to 1037		100	2600	SAT	700	
The bolt group was removed and lubricated.						
1106 to 1108		100	2700	SAT	714	
1128 to 1130		100	2800	SAT	703	
1256 to 1258		100	2900	SAT	694	
1324 to 1326		100	3000	SAT	635	
1335 to 1339		100	3100	12-BOB	600	7 Stoppages w/mag. 11A and 5 with 11B.
The bolt group was removed and lubricated. The gas tube was subjected to X-Ray, air flow measurement and weighing. Headspace 1.502 in.						
1623 to 1625		100	3200	SAT	716	
1644 to 1646		100	3300	SAT	728	
1705 to 1707		100	3400	SAT	675	
1724 to 1726		100	3500	SAT	648	
1745 to 1747		100	3600	SAT	671	
The bolt group was removed and lubricated.						
1847 to 1849		100	3700	SAT	748	
1902 to 1904		100	3800	SAT	726	
1921 to 1923		100	3900	SAT	696	
1940 to 1942		100	4000	SAT	710	
2000 to 2002		100	4100	SAT	691	

<u>Time</u>	<u>Gunner</u>	<u>Rds</u>	<u>Total Rds</u>	<u>Function</u>	<u>Cyclic Rate (Rds/Min)</u>	<u>Remarks</u>
16 February 1968						
1028 to 1052	Jastrzembski	50	4150	3-FJ		Accuracy Test
The rifle was disassembled, cleaned, inspected and lubricated.						
Headspace 1.502 in.						
Firing pin protrusion 0.034 in.						
Firing pin indent 0.022 in.						
Firing pin diameter 0.060 in.						
Firing pin hole diameter in bolt 0.063 in.						
Free length of ejector spring 0.88 in.						
Free length of extractor spring 0.23 in.						
Free length of action spring 12.2 in.						
Magazine 11C was replaced with 11C1.						
17 February 1968						
0840 to 0842	Steele	100	4250	SAT	789	
0857 to 0859		100	4350	SAT	781	The snap ring was
lost and this permitted the ejection port cover pin to disengage at its forward end.						
0918 to 0920		100	4450	SAT	735	
0939 to 0941		100	4550	SAT	722	
1003 to 1005		100	4650	1-FBR	666	Malfunction w/mag. 11A
The bolt group was removed and lubricated.						
1048 to 1050		100	4750	SAT	698	
1110 to 1112		100	4850	SAT	714	
1131 to 1133		100	4950	SAT	699	
1319 to 1321		100	5050	SAT	708	
1333 to 1335		100	5150	SAT	719	
The bolt group was removed and lubricated. The gas tube was subjected to X-Ray,						
air flow measurement and weighing. Headspace 1.502 in.						
1612 to 1614	Steele	100	5250	SAT	769	
1634 to 1636		100	5350	SAT	765	
1702 to 1704		100	5450	SAT	724	
1725 to 1727		100	5550	SAT	710	
1745 to 1747		100	5650	1-BOB	694	Stoppage w/mag. 11A
The bolt group was removed and lubricated.						
1841 to 1843		100	5750	SAT	769	
1906 to 1908		100	5850	2-F2R	759	
1925 to 1930		100	5950	6-F2R	705	
1947 to 1949		100	6050	2-F2R	702	
2007 to 2010		100	6150	4-F2R	710	

<u>Time</u>	<u>Gunner</u>	<u>Rds</u>	<u>Total Rds</u>	<u>Function</u>	<u>Cyclic Rate (Rds/Min)</u>	<u>Remarks</u>
19 February 1968						
1035 to 1105	Jastrzemski	50	6200	2-FJ		Accuracy Test
The rifle was disassembled, cleaned, inspected and lubricated.						
Headspace 1.502 in.						
Firing pin protrusion 0.034 in.						
Firing pin indent 0.022 in.						
Firing pin diameter 0.060 in.						
Firing pin hole diameter to bolt 0.063 in.						
Free length of ejector spring 0.89 in.						
Free length of extractor spring 0.22 in.						
Free length of action spring 12.1 in.						
The disconnecter was replaced. A new snap ring was assembled to retain the ejection port cover pin.						
20 February 1968						
0856 to 0858	Sneade	100	6300	SAT	826	Mag. 11D was difficult to insert in and remove from the rifle.
0914 to 0916		100	6400	SAT	766	
0942 to 0944		100	6500	SAT	Not Recorded	
1013 to 1015		100	6600	1-BOB	636	BOB with mag. 11B
				1-FBR		FBR with mag. 11A
1042 to 1045		100	6700	3-BOB	678	2 BOB and FBR with mag. 11A
				1-FBR		1 BOB with mag. 11B
The bolt group was removed and lubricated.						
1126 to 1128		100	6800	SAT	772	
1141 to 1144		100	6900	SAT	743	
1301 to 1303		100	7000	SAT	737	
1322 to 1324		100	7100	SAT	702	
1337 to 1339		100	7200	SAT	682	
The bolt group was removed and lubricated. The gas tube was subjected to X-Ray, air flow measurement and weighing. Headspace 1.503 in.						
1610 to 1612		100	7300	SAT	726	
1633 to 1635		100	7400	SAT	733	
1657 to 1659		100	7500	SAT	746	
1725 to 1727		100	7600	SAT	726	
1745 to 1747		100	7700	SAT	708	
The bolt group was removed and lubricated.						
1842 to 1844		100	7800	SAT	779	
1911 to 1913		100	7900	SAT	764	
1932 to 1934		100	8000	SAT	773	
1953 to 1955		100	8100	SAT	754	
2012 to 2014		100	8200	SAT	722	

<u>Time</u>	<u>Gunner</u>	<u>Rds</u>	<u>Total Rds</u>	<u>Function</u>	<u>Cyclic Rate (Rds/Min)</u>	<u>Remarks</u>
21 February 1968						
1043 to 1110	Jastrzemski	50	8250	SAT		Accuracy Test
The rifle was disassembled, cleaned, inspected and lubricated.						
Headspace 1.503 in.						
Firing pin protrusion 0.033 in.						
Firing pin indent 0.022 in.						
Firing pin diameter 0.060 in.						
Firing pin hole diameter in bolt 0.063 in.						
Free length of ejector spring 0.88 in						
Free length of extractor spring 0.22 in.						
Free length of action spring 12.1 in.						
23 February 1968						
0851 to 0853	Folweiler	100	8350	SAT	816	
0911 to 0913		100	8450	SAT	792	
0929 to 0931		100	8550	SAT	765	
0948 to 0950		100	8650	SAT	774	
1008 to 1010		100	8750	SAT	756	
The bolt group was removed and lubricated.						
1050 to 1052		100	8850	SAT	806	
1110 to 1112		100	8950	1-FBR	786	Malfunction w/mag. 11Cl.
1128 to 1130		100	9050	SAT	797	
1254 to 1256		100	9150	SAT	779	
1313 to 1315		100	9250	SAT	728	
The bolt group was removed and lubricated. The gas tube was subjected to X-Ray, air flow measurement and weighing. Headspace 1.504 in.						
1554 to 1556		100	9350	SAT	786	
1617 to 1619		100	9450	SAT	746	
1640 to 1642		100	9550	SAT	774	
1707 to 1709		100	9650	SAT	772	
1736 to 1738		100	9750	SAT	754	
The bolt group was removed and lubricated.						
1848 to 1850		100	9850	SAT	800	
1909 to 1911		100	9950	SAT	775	
1928 to 1930		100	10,050	SAT	740	
1945 to 1947		100	10,150	SAT	749	
2001 to 2003		100	10,250	SAT	699	The ejection port cover pin disengaged at its forward end because the snap ring was lost.

<u>Time</u>	<u>Gunner</u>	<u>Rds</u>	<u>Total Rds</u>	<u>Function</u>	<u>Cyclic Rate (Rds/Min)</u>	<u>Remarks</u>
1025 to 1050	Jastrzembski	50	10,300	1-FJ		Accuracy Test

24 February 1968

The rifle was disassembled, cleaned, inspected and lubricated.

Headspace 1.503 in.

Firing pin protrusion 0.033 in.

Firing pin indent 0.022 in.

Firing pin diameter 0.060 in.

Firing pin hole diameter in bolt 0.063 in.

Free length of ejector spring 0.89 in.

Free length of extractor spring 0.21 in.

Free length of action spring 12.1 in.

<u>Time</u>	<u>Gunner</u>	<u>Rds</u>	<u>Total Rds</u>	<u>Function</u>	<u>Cyclic Rate (Rds/Min)</u>	<u>Remarks</u>
Rifle 5.56mm, M16A1, No. 863632 (12)						
Cartridge, 5.56mm, Ball, M193, Lot No. TW18191						
8 January 1968						
The rifle was inspected.						
Headspace 1.502 in.						
Firing pin protrusion 0.035 in.						
Firing pin indent 0.023 in.						
Firing pin diameter 0.060 in.						
Firing pin hole diameter in bolt 0.063 in.						
Free length of ejector spring 0.92 in.						
Free length of extractor spring 0.23 in.						
Free length of action spring 12.0 in.						
Action spring rate 1.43 lbs./in.						
24 February 1968						
1438 to 1505	Jastrzemski	50	50	SAT		Accuracy Test
26 February 1968						
0850 to 0852	Steele	100	150	SAT	782	
0910 to 0912		100	250	SAT	759	
0935 to 0937		100	350	SAT	754	
0959 to 1001		100	450	SAT	703	
1022 to 1024		100	550	SAT	691	
The bolt group was removed and lubricated.						
1100 to 1102		100	650	SAT	737	
1122 to 1124		100	750	SAT	730	
1141 to 1143		100	850	SAT	732	
1304 to 1306		100	950	SAT	738	
Cartridge, 5.56mm, Ball, M193, Lot No. RA5320 (fired inadvertently)						
1326 to 1328		100	1050	SAT	831	Magazines for
rifle 861015(9) were used.						
Cartridge, 5.56mm, Ball, M193, Lot TW18191						
1328		20	1070	SAT	663	Fired automatically
The bolt group was removed and lubricated. The gas tube was subjected to X-Ray, air flow measurement and weighing. Headspace 1.502 in. The stock was cracked on the left side at the point of contact with the Springfield Armory firing jack.						
1614 to 1616		100	1170	SAT	725	
1637 to 1639		100	1270	SAT	709	
1705 to 1707		100	1370	SAT	693	
1731 to 1733		100	1470	1-FS	658	Stoppage on 1st rd
in mag. 12D.						
1753 to 1755		100	1570	2-FF 1-FBR	673	Malfunctions w/mag. 12A
The bolt group was removed and lubricated.						
1849 to 1851		100	1670	SAT	707	
1916 to 1921		100	1770	1-FFR	675	The stoppage was caused
by a failure of the bolt to lock. The bolt could not be locked with the bolt assist.						
1938 to 1942		100	1870	3-BOB 1-FF	680	2 stoppages with each mag. 12A and 12B.

<u>Time</u>	<u>Gunner</u>	<u>Rds</u>	<u>Total Rds</u>	<u>Function</u>	<u>Cyclic Rate (Rds/Min)</u>	<u>Remarks</u>
1956 to 1958		100	1970	SAT	709	
2012 to 2014		100	2070	1-FBR	692	Malfunction w/mag. 12A
27 February 1968						
1030 to 1100	Jastrzemski	50	2120	SAT		Accuracy Test
The rifle was disassembled, cleaned, inspected and lubricated.						
Headspace 1.503 in.						
Firing pin protrusion 0.035 in.						
Firing pin indent 0.022 in						
Firing pin diameter 0.060 in.						
Firing pin hole diameter in bolt 0.064 in.						
Free length of ejector spring 0.89 in.						
Free length of extractor spring 0.22 in.						
Free length of action spring 12.0 in.						
The firing pin was deformed at the rear of the profile.						
28 February 1968						
0844 to 0846	Sneade	100	2220	SAT	760	
0908 to 0910		100	2320	SAT	735	
0940 to 0942		100	2420	SAT	728	
1007 to 1009		100	2520	SAT	719	
1029 to 1031		100	2620	SAT	710	
The bolt group was removed and lubricated.						
1103 to 1105		100	2720	SAT	751	
1126 to 1128		100	2820	SAT	757	
1142 to 1144		100	2920	SAT	739	
1255 to 1257		100	3020	SAT	724	
1315 to 1317		100	3120	SAT	689	
The bolt group was removed and lubricated. The gas tube was subjected to X-Ray, air flow measurement and weighing. Headspace 1.503 in. The stock was cracked on both sides at the points of contact with the Springfield Armory firing jack.						
1619 to 1621		100	3220	SAT	751	
1642 to 1644		100	3320	SAT	731	
1711 to 1713		100	3420	SAT	746	
1735 to 1737		100	3520	SAT	720	
1750 to 1752		100	3620	SAT	691	
The bolt group was removed and lubricated.						
1847 to 1849		100	3720	SAT	745	
1909 to 1911		100	3820	SAT	751	
1930 to 1932		100	3920	SAT	746	
1943 to 1945		100	4020	SAT	732	
1959 to 2001		100	4120	SAT	683	

<u>Time</u>	<u>Gunner</u>	<u>Rds</u>	<u>Total Rds</u>	<u>Function</u>	<u>Cyclic Rate (Rds/Min)</u>	<u>Remarks</u>
29 February 1968						
1030 to 1055	Jastrzembki	50	4170	SAT		Accuracy Test
The rifle was disassembled, cleaned, inspected and lubricated.						
Headspace 1.503 in.						
Firing pin protrusion 0.035 in.						
Firing pin indent 0.022 in.						
Firing pin diameter 0.060 in.						
Firing pin hole diameter in bolt 0.064 in.						
Free length of ejector spring 0.88 in.						
Free length of extractor spring 0.21 in.						
Free length of action spring 12.0 in.						
1 March 1968						
0848 to 0850	Folweiler	100	4270	SAT	770	
0913 to 0915		100	4370	SAT	786	
0939 to 0941		100	4470	SAT	773	
0959 to 1001		100	4570	SAT	770	
1022 to 1024		100	4670	SAT	755	
The bolt group was removed and lubricated.						
1053 to 1055		100	4770	SAT	786	
1116 to 1118		100	4870	SAT	761	
1131 to 1133		100	4970	SAT	737	
1252 to 1254		100	5070	SAT	755	
1325 to 1327		100	5170	SAT	765	
The bolt group was removed and lubricated. The gas tube was subjected to X-Ray, air flow measurement and weighing. Headspace 1.503 in.						
1621 to 1623		100	5270	SAT	768	
1644 to 1646		100	5370	SAT	774	
1710 to 1712		100	5470	SAT	768	
1733 to 1735		100	5570	SAT	764	
lost and this permitted the ejection port cover pin to disengage at its forward end.						
1751 to 1753		100	5670	SAT	769	The snap ring was
The bolt group was removed and lubricated.						
1849 to 1851		100	5770	SAT	751	
1909 to 1911		100	5870	SAT	745	
1929 to 1931		100	5970	SAT	763	
1948 to 1950		100	6070	SAT	748	
2007 to 2009		100	6170	SAT	706	

<u>Time</u>	<u>Gunner</u>	<u>Rds</u>	<u>Total Rds</u>	<u>Function</u>	<u>Cyclic Rate (Rds/Min)</u>	<u>Remarks</u>
2 March 1968						
1030 to 1100	Jastrzembski	50	6220	SAT		Accuracy Test
The rifle was disassembled, cleaned, inspected and lubricated. Headspace 1.503 in. Firing pin protrusion 0.035 in. Firing pin indent 0.021 in. Firing pin diameter 0.060 in. Firing pin hole diameter in bolt 0.064 in. Free length of ejector spring 0.88 in. Free length of extractor spring 0.21 in. Free length of action spring 12.0 in.						
4 March 1968						
0839 to 0841	Steele	100	6320	SAT	757	
0901 to 0903		100	6420	SAT	785	
0929 to 0931		100	6520	SAT	760	
0957 to 0959		100	6620	1-FBR	752	Malfunction w/mag. 12A
1017 to 1019		100	6720	SAT	749	
The bolt group was removed and lubricated.						
1051 to 1053		100	6820	SAT	763	
1113 to 1115		100	6920	SAT	766	
1132 to 1134		100	7020	SAT	766	
1252 to 1254		100	7120	SAT	755	
1315 to 1317		100	7220	SAT	737	Breech sparks on 1 rd
The bolt group was removed and lubricated. The gas tube was subjected to X-Ray, air flow measurement and weighing. Headspace 1.504+ in.						
5 March 1968						
0830 to 0832		100	7320	SAT	772	
0854 to 0856		100	7420	SAT	793	
0918 to 0920		100	7520	SAT	763	
0949 to 0951		100	7620	SAT	768	
1018 to 1020		100	7720	SAT	763	
The bolt group was removed and lubricated.						
1107 to 1109		100	7820	SAT	770	
1124 to 1126		100	7920	SAT	773	
1139 to 1141		100	8020	SAT	790	
1256 to 1258		100	8120	SAT	764	
1316 to 1318		100	8220	SAT	789	
1537 to 1605	Jastrzembski	50	8270	SAT		Accuracy Test

<u>Time</u>	<u>Gunner</u>	<u>Rds</u>	<u>Total Rds</u>	<u>Function</u>	<u>Cyclic Rate (Rds/Min)</u>	<u>Remarks</u>
6 March 1968						
The rifle was disassembled, cleaned, inspected and lubricated.						
Headspace 1.504+ in.						
Firing pin protrusion 0.035 in.						
Firing pin indent 0.022 in.						
Firing pin diameter 0.060 in.						
Firing pin hole diameter in bolt 0.064 in.						
Free length of ejector spring 0.88 in.						
Free length of extractor spring 0.20 in.						
Free length of action spring 12.0 in.						
1314 to 1316	Sneade	100	8370	SAT	809	
1336 to 1338		100	8470	SAT	854	
1404 to 1406		100	8570	SAT	817	
1434 to 1436		100	8670	SAT	817	
1503 to 1505		100	8770	SAT	832	
The bolt group was removed and lubricated.						
1540 to 1542		100	8870	SAT	806	
1602 to 1604		100	8970	SAT	813	1 Split case
7 March 1968						
0832 to 0834		100	9070	SAT	775	
0850 to 0852		100	9170	SAT	756	
0912 to 0914		100	9270	SAT	737	
The bolt group was removed and lubricated. The gas tube was subjected to X-Ray, air flow measurement and weighing. Headspace 1.504+ in.						
1257 to 1259		100	9370	SAT	800	
1313 to 1315		100	9470	SAT	750	
1336 to 1338		100	9570	SAT	730	
1354 to 1356		100	9670	SAT	726	
1413 to 1415		100	9770	SAT	726	
The bolt group was removed and lubricated.						
1440 to 1442		100	9870	SAT	760	
1455 to 1457		100	9970	SAT	741	
1514 to 1516		100	10,070	SAT	737	
1528 to 1530		100	10,170	SAT	725	
1544 to 1546		100	10,270	SAT	683	

<u>Time</u>	<u>Gunner</u>	<u>Rds</u>	<u>Total Rds</u>	<u>Function</u>	<u>Cyclic Rate (Rds/Min)</u>	<u>Remarks</u>
1010 to 1035	Jastrzembski	60	10,320	SAT		Accuracy Test

8 March 1968

The rifle was disassembled, cleaned, inspected and lubricated.
 Headspace 1.504+ in.

Firing pin protrusion 0.035 in.

Firing pin indent 0.022 in.

Firing pin diameter 0.060 in.

Firing pin hole diameter in bolt 0.064 in.

Free length of ejector spring 0.88 in.

Free length of extractor spring 0.26 in.

Free length of action spring 11.9 in.

The extractor spring was broken. It was replaced.

<u>Time</u>	<u>Gunner</u>	<u>Rds</u>	<u>Total Rds</u>	<u>Function</u>	<u>Cyclic Rate (Rds/Min)</u>	<u>Remarks</u>
						Rifle 5.56mm, M16A1, No. 863749 (13) Cartridge, 5.56mm, Ball, M193, Lot No. 5244 8 January 1968 The rifle was inspected. Headspace 1.500 in. Firing pin protrusion 0.034 in. Firing pin indent 0.020 in. Firing pin diameter 0.060 in. Firing pin hole diameter in bolt 0.063 in. Free length of ejector spring 0.91 in. Free length of extractor spring 0.24 in. Free length of action spring 12.2 in. Action spring rate 1.29 lbs./in. The original gas tube was replaced with one which had a burr inside of the tube at the port.
0840	Steele	1	1	SAT		11 March 1968 The rifle was disassembled and inspected. The burr was missing from the gas tube and it could not be located.

APPENDIX H

ACCURACY AND VELOCITY TEST DATA

Measurements for 10-shot targets are given in inches.
Velocity at 15 feet from the muzzle is given in feet per second.
Time is given in seconds $\times 10^{-6}$.

LEGEND:

MR = Mean radius

MVD = Mean vertical deviation

MHD = Mean horizontal deviation

EVD = Extreme vertical deviation

EHD = Extreme horizontal deviation

ES = Extreme spread

ACCURACY TEST

Date: 31 January 1968
 Time: 1313 to 1610
 Range: 100 Yards

Temperature: 50F
 Barometer: 30.45 in
 Relative Humidity: 68%

Target Number	Center of Impact from Index Point		MR	MVD	MHD	EVD	EHD	ES
	X	Y						
<u>Rifle No. 843489(1)</u>			<u>Rounds Previously Fired in Rifle: 0</u>					
			<u>Cartridge Lot: RA5244</u>					
1	+ 0.6	- 8.9	1.35	0.88	0.89	3.9	4.0	4.2
2	- 0.4	- 8.4	1.27	0.88	0.85	3.4	3.3	4.7
3	- 1.0	- 7.7	1.45	1.21	0.59	4.5	2.6	4.7
4	- 2.0	- 6.9	1.28	0.96	0.76	3.0	2.7	4.0
5	- 2.1	- 5.8	1.28	1.06	0.50	4.6	1.9	4.6
Average	- 1.0	- 7.5	1.33	1.00	0.72	3.9	2.9	4.4

<u>Rifle No. 855603(4)</u>			<u>Rounds Previously Fired in Rifle: 0</u>					
			<u>Cartridge Lot: TW18179</u>					
1	- 2.4	+ 0.4	1.62	1.10	0.91	6.5	5.9	7.6 ^a
2	- 1.1	+ 1.3	0.69	0.39	0.48	2.6	1.6	2.9
3	- 0.9	+ 1.6	0.62	0.38	0.41	1.4	1.4	1.5
4	- 1.1	+ 2.3	0.87	0.63	0.53	2.1	1.7	2.4
5	- 0.7	+ 2.8	0.56	0.25	0.42	1.3	1.6	1.6
Average	- 1.2	+ 1.7	0.87	0.55	0.55	2.8	2.4	3.2

<u>Rifle No. 859129(7)</u>			<u>Rounds Previously Fired in Rifle: 0</u>					
			<u>Cartridge Lot: RA5320</u>					
1	+ 3.4	-11.8	1.22	0.86	0.79	4.1	4.7	6.2 ^b
2	+ 4.6	-10.3	1.00	0.74	0.48	3.2	1.7	3.4
3	+ 5.6	- 9.2	1.16	0.56	0.90	2.2	3.1	3.4
4	+ 6.3	- 8.0	0.71	0.47	0.49	2.0	2.1	2.4
5	+ 7.5	- 8.2	1.02	0.53	0.76	2.5	3.2	3.6
Average	+ 5.5	- 9.5	1.02	0.63	0.68	2.8	3.0	3.8

<u>Rifle No. 862235(10)</u>			<u>Rounds Previously Fired in Rifle: 0</u>					
			<u>Cartridge Lot: TW18191</u>					
1	+ 6.4	- 4.2	1.33	0.79	0.90	5.0	5.2	6.5 ^c
2	+ 5.1	- 2.3	0.78	0.57	0.42	2.9	1.8	3.2
3	+ 4.7	- 1.0	0.82	0.48	0.54	1.8	2.6	2.7
4	+ 3.8	- 1.4	0.94	0.68	0.51	3.2	2.0	3.3
5	+ 3.2	- 0.5	1.14	0.53	0.87	2.1	4.7	4.7
Average	+ 4.6	- 1.9	1.00	0.61	0.65	3.0	3.3	4.1

a 9 Shots in 3.4 b 9 Shots in 3.6 c 9 Shots in 2.9

VELOCITY DATA

Date: 31 January 1968

<u>Target 1</u>		<u>Target 2</u>		<u>Target 3</u>		<u>Target 4</u>		<u>Target 5</u>	
<u>Time</u>	<u>Velocity</u>	<u>Time</u>	<u>Velocity</u>	<u>Time</u>	<u>Velocity</u>	<u>Time</u>	<u>Velocity</u>	<u>Time</u>	<u>Velocity</u>
<u>Rifle 843489(1) and Cartridge Lot RA5244</u>						<u>Time: 1313 to 1404</u>			
6316	3167		*	6310	3170	6455	3098	6208	3222
6421	3115	6315	3167	6330	3160	6307	3171	6355	3147
6383	3133		*	6243	3204	6393	3128	6331	3159
6435	3108		*	6321	3164	6342	3154	6232	3209
6357	3146	6313	3168	6265	3192	6299	3175	6354	3148
6352	3149	6319	3165	6237	3207	6264	3193	6244	3203
6292	3179	6306	3172	6328	3161	6295	3177	6271	3189
6284	3183	6286	3182	6297	3176	6205	3223	6327	3161
6178	3237	6399	3125	6248	3201	6347	3151	6276	3187
	*	6263	3193	6259	3195	6287	3181	6312	3169
Mean	3157		3167		3183		3165		3179
Ex Var	129		68		47		125		75
Std Dev	37		20		18		33		25

Rifle 855603(4) and Cartridge Lot TW18179 Time: 1410 to 1450

6441	3105	6464	3094	6516	3069	6445	3103	6407	3122
6420	3115	6439	3106	6434	3108	6471	3091	6503	3076
6391	3129	6433	3109	6472	3090	6534	3061	6475	3089
6365	3142	6367	3141	6511	3072	6463	3095	6541	3058
6528	3064	6425	3113	6365	3142	6412	3119	6399	3125
6378	3136	6448	3102	6442	3105	6417	3117	6421	3115
6459	3096	6441	3105	6419	3116	6363	3143	6389	3130
6448	3102	6366	3142	6485	3084	6400	3125	6447	3102
6450	3101	6486	3084	6413	3119	6483	3085	6465	3094
6488	3083	6445	3103	6367	3141	6460	3096	6433	3109
Mean	3107		3110		3105		3104		3102
Ex Var	78		58		73		82		72
Std Dev	23		18		25		22		22

* Not Recorded

VELOCITY DATA

Date: 31 January 1968

<u>Target 1</u>		<u>Target 2</u>		<u>Target 3</u>		<u>Target 4</u>		<u>Target 5</u>	
<u>Time</u>	<u>Velocity</u>	<u>Time</u>	<u>Velocity</u>	<u>Time</u>	<u>Velocity</u>	<u>Time</u>	<u>Velocity</u>	<u>Time</u>	<u>Velocity</u>
<u>Rifle 859129(7) and Cartridge Lot RA5320</u>						<u>Time: 1500 to 1530</u>			
6215	3218	6286	3182	6249	3201	6338	3156	6280	3185
6251	3199	6242	3204	6270	3190	6256	3197	6237	3207
6300	3175	6334	3158	6259	3195	6380	3135	6284	3183
6270	3190	6242	3204	6264	3193	6325	3162	6369	3140
6229	3211	6265	3192	6243	3204	6304	3173	6252	3199
6245	3203	6215	3218	6352	3149	6295	3177	6243	3204
6244	3203	6193	3229	6290	3180	6279	3185	6236	3207
6311	3169	6272	3189	6213	3219	6238	3206	6284	3183
6299	3175	6240	3205	6221	3215	6177	3238	6294	3178
6270	3190	6222	3214	6256	3197	6219	3216	6305	3172
Mean	3193		3200		3194		3185		3186
Ex Var	49		71		70		103		67
Std Dev	16		19		19		29		19

<u>Rifle 862235(10) and Cartridge Lot TW18191</u>						<u>Time: 1542 to 1610</u>			
6303	3173	6384	3133	6365	3142	6386	3132	6430	3110
6350	3150	6401	3124	6363	3143	6290	3180	6320	3165
6336	3157	6496	3079	6390	3130	6369	3140	6374	3138
6414	3118	6359	3145	6320	3165	6387	3131	6404	3123
6377	3136	6358	3146	6444	3104	6327	3161	6443	3104
6428	3111	6302	3174	6377	3136	6378	3136	6299	3175
6334	3158	6354	3148	6370	3140	6316	3167	6350	3150
6378	3136	6401	3124	6392	3129	6469	3092	6390	3130
6371	3139	6390	3130	6329	3160	6395	3127	6365	3142
6322	3164	6404	3123	6389	3130	6372	3139	6361	3144
Mean	3144		3133		3138		3141		3138
Ex Var	62		95		61		88		71
Std Dev	19		23		16		23		21

ACCURACY TEST

Date: 2 February 1968	Temperature: <u>Start</u> 50F	<u>Finish</u> 50F
Time: 1300 to 1535	Barometer: 29.95 in	29.89 in
Range: 100 Yards	Relative Humidity: 80%	80%

Target Number	Center of Impact from Index Point		<u>MR</u>	<u>MVD</u>	<u>MHD</u>	<u>EVD</u>	<u>EHD</u>	<u>ES</u>
	<u>X</u>	<u>Y</u>						
<u>Rifle No. 843489(1)</u>			<u>Rounds Previously Fired in Rifle: 2050</u>					
			<u>Cartridge Lot: RA5244</u>					
1	+ 1.0	-10.5	1.63	1.42	0.53	7.5	2.1	7.6 ^a
2	+ 1.4	-10.1	0.68	0.36	0.49	1.6	1.9	2.4
3	+ 0.9	-10.1	0.87	0.78	0.23	2.7	1.1	2.8
4	0.0	- 8.0	1.15	0.76	0.70	4.1	2.1	4.4
5	+ 0.1	- 5.6	0.81	0.43	0.53	1.5	3.0	3.0
Average	+ 0.7	- 8.9	1.03	0.75	0.50	3.5	2.0	4.0

<u>Rifle No. 855603(4)</u>			<u>Rounds Previously Fired in Rifle: 2050</u>					
			<u>Cartridge Lot: TW18179</u>					
1	-10.0	+ 1.0	1.14	0.72	0.75	3.2	4.5	5.2 ^b
2	-10.7	+ 1.9	0.85	0.69	0.40	2.1	1.8	2.3
3	-10.5	+ 3.2	0.81	0.58	0.46	3.4	1.7	3.7
4	-10.8	+ 3.7	1.12	0.93	0.54	4.0	2.0	4.3
5	-11.2	+ 3.8	0.90	0.50	0.59	2.1	3.2	3.3
Average	-10.6	+ 2.7	0.96	0.68	0.55	3.0	2.6	3.8

<u>Rifle No. 859129(7)</u>			<u>Rounds Previously Fired in Rifle: 2050</u>					
			<u>Cartridge Lot: RA5320</u>					
1	- 0.4	- 7.1	1.67	1.33	0.92	6.5	3.6	7.1 ^c
2	- 2.2	- 5.0	1.28	1.13	0.51	3.7	1.9	3.9
3	- 2.8	- 2.1	1.63	1.16	0.90	4.9	4.2	5.2
4	- 1.9	- 1.8	1.31	0.98	0.55	3.4	3.7	3.9
5	- 1.5	- 2.5	0.73	0.57	0.37	2.2	1.6	2.6
Average	- 1.8	- 3.7	1.32	1.03	0.65	4.1	3.0	4.5

<u>Rifle No. 862235(10)</u>			<u>Rounds Previously Fired in Rifle: 2050</u>					
			<u>Cartridge Lot: TW18191</u>					
1	+ 3.5	- 6.5	1.30	0.88	0.75	4.3	4.2	4.4
2	+ 1.9	- 6.1	0.94	0.47	0.65	2.1	2.7	2.7
3	+ 1.7	- 5.5	0.95	0.52	0.71	2.6	2.2	3.4
4	+ 1.4	- 5.2	0.68	0.45	0.41	1.9	1.7	2.0
5	+ 1.3	- 4.4	0.56	0.33	0.31	2.0	1.0	2.1
Average	+ 2.0	- 5.5	0.89	0.53	0.57	2.6	2.4	2.9

a 9 Shots in 4.6

b 9 Shots in 2.6

c 9 Shots in 4.3

VELOCITY DATA

Date: 2 February 1968

<u>Target 1</u>		<u>Target 2</u>		<u>Target 3</u>		<u>Target 4</u>		<u>Target 5</u>	
<u>Time</u>	<u>Velocity</u>	<u>Time</u>	<u>Velocity</u>	<u>Time</u>	<u>Velocity</u>	<u>Time</u>	<u>Velocity</u>	<u>Time</u>	<u>Velocity</u>
Rifle 843489(1) and Cartridge Lot RA5244									
6321	3164	6378	3136	6412	3119	6481	3086	6313	3168
6335	3157	6299	3175	6292	3179	6393	3128	6325	3162
6417	3117	6414	3118	6297	3176	6337	3156	6309	3170
6269	3190	6313	3168	6354	3148	6329	3160	6323	3163
6347	3151	6284	3183	6364	3143	6370	3140	6400	3125
6287	3181	6485	3084	6319	3165	6345	3152	6228	3211
6347	3107	6227	3213	6285	3182	6350	3150	6196	3228
6461	3095	6349	3150	6319	3165	6325	3162	6322	3164
6217	3217	6361	3144	6332	3159	6427	3112	6313	3168
6193	3229	6273	3188	6278	3186	6278	3186	6266	3192
Mean	3161		3156		3162		3143		3175
Ex Var	134		128		67		100		103
Std Dev	43		35		20		27		27

Rifle 855603(4) and Cartridge Lot TW18179

Time: 1345 to 1410

6514	3070	6484	3085	6682	2993	6721	2976	6502	3076
6528	3063	6491	3081	6508	3073	6625	3019	6581	3039
6513	3071	6621	3021	6682	2993	6598	3031	6532	3062
6502	3076	6551	3053	6583	3038	6574	3042	6540	3058
6569	3045	6528	3064	6638	3013	6462	3095	6455	3098
6506	3074	6591	3034	6537	3060	6543	3057	6454	3099
6507	3074	6558	3050	6627	3018	6548	3054	6569	3045
6511	3072	6504	3075	6556	3051	6507	3074	6474	3089
6545	3056	6500	3077	6623	3020	6459	3096	6621	3021
6696	2987	6639	3013	6578	3040	6422	3114	6480	3086
Mean	3059		3055		3030		3056		3067
Ex Var	79		72		80		138		77
Std Dev	26		24		26		39		25

VELOCITY DATA

Date: 2 February 1968

<u>Target 1</u>		<u>Target 2</u>		<u>Target 3</u>		<u>Target 4</u>		<u>Target 5</u>	
<u>Time</u>	<u>Velocity</u>	<u>Time</u>	<u>Velocity</u>	<u>Time</u>	<u>Velocity</u>	<u>Time</u>	<u>Velocity</u>	<u>Time</u>	<u>Velocity</u>
<u>Rifle 859129(7) and Cartridge Lot RA5320</u>									
6349	3128	6309	3170	6416	3117	6320	3165	6310	3170
6305	3172	6394	3128	6435	3108	6275	3187	6270	3190
6293	3178	6430	3110	6230	3210	6335	3157	6229	3211
6289	3180	6348	3151	6311	3169	6372	3139	6240	3205
6428	3111	6329	3160	6303	3173	6324	3163	6360	3145
6272	3189	6286	3182	6371	3139	6363	3143	6422	3114
6342	3154	6365	3142	6331	3159	6220	3215	6320	3165
6286	3182	6357	3146	6315	3167	6339	3155	6287	3181
6384	3133	6330	3160	6342	3154	6330	3160	6344	3153
6404	3123	6313	3168	6341	3154	6331	3159	6228	3211
Mean	3155		3152		3155		3164		3174
Ex Var	78		72		102		76		97
Std Dev	27		20		28		21		30

Rifle 862235(10) and Cartridge Lot TW18191

Time: 1507 to 1535

6402	3124	6442	3105	6494	3080	6477	3088	6476	3088
6402	3124	6443	3104	6411	3120	6492	3081	6460	3096
6409	3121	6385	3132	6514	3070	6434	3108	6523	3066
6470	3091	6611	3025	6496	3079	6508	3073	6577	3041
6437	3107	6400	3125	6421	3115	6546	3055	6414	3118
6434	3108	6362	3144	6448	3102	6448	3102	6469	3092
6395	3127	6418	3116	6483	3085	6504	3075	6513	3071
6437	3107	6444	3104	6429	3111	6476	3088	6463	3095
6500	3077	6452	3100	6370	3140	6442	3105	6529	3063
6395	3127	6476	3088	6437	3107	6424	3113	6472	3090
Mean	3111		3104		3101		3089		3082
Ex Var	50		119		70		58		77
Std Dev	16		31		21		17		21

ACCURACY TEST

Date: 5 February 1968
 Time: 0845 to 1109
 Range: 100 Yards

Temperature:
 Barometer:
 Relative Humidity:

Start Finish
 51F 52F
 30.20 in 30.21 in
 29% 26%

Target Number	Center of Impact from Index Point		MR	MVD	MHD	EVD	EHD	ES
	X	Y						

Rifle No. 843489(1) Rounds Previously Fired in Rifle: 4097
Cartridge Lot: RA5244

1	+ 4.7	- 1.3	0.92	0.59	0.52	2.7	2.7	3.1
2	+ 4.9	- 3.5	1.00	0.78	0.48	3.6	1.6	3.7
3	+ 5.8	- 1.9	1.86	0.79	1.58	2.9	5.5	5.6
4	+ 5.5	- 2.8	0.62	0.35	0.41	1.8	1.9	2.0
5	+ 5.1	- 1.8	1.35	0.98	0.75	3.9	2.9	4.0
Average	+ 5.2	- 2.3	1.15	0.70	0.75	3.0	2.9	3.7

Rifle No. 855603(4) Rounds Previously Fired in Rifle: 4100
Cartridge Lot: TW18179

1	- 2.2	+ 6.5	1.09	0.90	0.39	5.5	2.0	5.6 ^a
2	- 3.2	+ 7.7	1.24	0.77	0.82	3.0	3.1	3.5
3	- 2.9	+ 8.0	0.88	0.59	0.52	2.0	2.5	2.8
4	- 3.8	+ 8.8	1.18	0.63	0.96	2.6	3.6	4.4 ^b
5	- 4.0	+ 8.7	1.20	0.96	0.63	4.2	2.3	4.6 ^b
Average	- 3.2	+ 7.9	1.12	0.77	0.66	3.5	2.7	4.2

Rifle No. 859129(7) Rounds Previously Fired in Rifle: 4099
Cartridge Lot: RA5320

1	+ 4.3	- 8.4	1.55	1.05	1.03	6.4	5.0	8.0 ^c
2	+ 6.6	- 4.9	1.16	0.94	0.51	3.8	1.9	4.1
3	+ 4.9	- 1.2	2.08	1.55	1.21	5.8	4.9	7.6
4	+ 1.3	- 1.8	1.61	1.11	1.06	4.0	4.5	5.7
5	+ 0.4	- 5.4	2.29	1.61	1.40	5.3	5.0	5.5
Average	+ 3.5	- 4.3	1.74	1.25	1.04	5.1	4.3	6.2

Rifle No. 862235(10) Rounds Previously Fired in Rifle: 4100
Cartridge Lot: TW18191

1	+ 7.3	- 1.5	1.53	1.08	0.97	3.6	3.6	4.5
2	+ 6.6	- 0.7	0.89	0.48	0.69	2.5	3.0	3.9
3	+ 6.0	- 0.8	1.08	0.53	0.89	2.3	3.6	4.1
4	+ 5.4	- 1.3	0.79	0.60	0.35	3.2	1.6	3.3
5	+ 4.7	- 0.9	0.74	0.29	0.64	1.5	2.3	2.4
Average	+ 6.0	- 1.0	1.01	0.60	0.71	2.6	2.8	3.6

a 9 Shots in 2.4

b 9 Shots in 2.6

c 9 Shots in 2.6

VELOCITY DATA

Date: 5 February 1968

<u>Target 1</u>		<u>Target 2</u>		<u>Target 3</u>		<u>Target 4</u>		<u>Target 5</u>	
<u>Time</u>	<u>Velocity</u>	<u>Time</u>	<u>Velocity</u>	<u>Time</u>	<u>Velocity</u>	<u>Time</u>	<u>Velocity</u>	<u>Time</u>	<u>Velocity</u>
<u>Rifle 843489(1) and Cartridge Lot RA5244</u>						<u>Time: 0845 to 0907</u>			
6273	3188	6311	3169	6224	3213	6237	3207	6140	3257
6182	3235	6326	3162	6267	3191	6238	3206	6257	3196
6315	3167	6336	3157	6233	3209	6195	3228	6343	3153
6327	3161	6340	3155	6379	3135	6198	3227	6262	3194
6292	3179	6377	3136	6317	3166	6323	3163	6213	3219
6317	3166	6277	3186	6328	3161	6218	3216	6187	3233
6160	3247	6299	3175	6295	3177	6148	3253	6154	3250
6494	3080	6412	3119	6346	3152	6153	3250	6229	3211
6295	3177	6356	3147	6231	3210	6319	3165	6227	3212
6334	3158	6349	3150	6226	3212	6258	3196	6175	3239
Mean	3176		3156		3183		3211		3216
Ex Var	167		67		78		90		104
Std Dev	43		18		27		29		29

<u>Rifle 855603(4) and Cartridge Lot TW18179</u>						<u>Time: 0915 to 0946</u>			
6381	3134	6421	3115	6469	3092	6469	3092	6512	3071
6357	3097	6478	3087	6486	3084	6389	3130	6434	3108
6412	3119	6560	3049	6483	3085	6474	3089	6388	3131
6506	3074	6407	3122	6430	3110	6424	3113	6389	3130
6438	3107	6413	3119	6483	3085	6402	3124	6452	3100
6412	3119	6544	3056	6437	3107	6521	3067	6483	3085
6369	3140	6516	3069	6434	3108	6505	3075	6381	3134
6575	3042	6448	3102	6520	3067	6470	3091	6607	3027
6467	3093	6487	3083	6502	3076	6312	3169	6487	3083
6383	3133	6446	3103	6433	3109	6436	3108	6465	3094
Mean	3106		3090		3092		3106		3096
Ex Var	98		73		43		102		107
Std Dev	29		25		15		28		31

VELOCITY DATA

Date: 5 February 1968

<u>Target 1</u>		<u>Target 2</u>		<u>Target 3</u>		<u>Target 4</u>		<u>Target 5</u>	
<u>Time</u>	<u>Velocity</u>	<u>Time</u>	<u>Velocity</u>	<u>Time</u>	<u>Velocity</u>	<u>Time</u>	<u>Velocity</u>	<u>Time</u>	<u>Velocity</u>
<u>Rifle 859129(7) and Cartridge Lot RA5320</u>									
6231	3210	6222	3214	6240	3205	6255	3197	6220	3215
6188	3232	6245	3203	6244	3203	6294	3178	6214	3219
6211	3220	6251	3199	6253	3198	6256	3197	6232	3209
6259	3195	6234	3208	6199	3226	6247	3202	6334	3158
6284	3183	6243	3204	6292	3179	6303	3173	6245	3203
6258	3196	6218	3216	6277	3186	6313	3168	6332	3159
6241	3205	6232	3209	6213	3219	6267	3191	6256	3197
6279	3185	6244	3203	6281	3184	6308	3171	6319	3165
6241	3205	6240	3205	6250	3200	6265	3192	6246	3202
6256	3197	6250	3200	6241	3205	6379	3135	6283	3183
Mean	3203		3206		3201		3180		3191
Ex Var	49		17		47		67		61
Std Dev	14		6		14		19		22

<u>Rifle 862235(10) and Cartridge Lot TW18191</u>						<u>Time: 1038 to 1109</u>			
6503	3076	6410	3120	6454	3099	6385	3132	6437	3107
6535	3060	6503	3076	6489	3082	6422	3114	6477	3088
6407	3122	6433	3109	6417	3117	6405	3123	6420	3115
6405	3123	6536	3060	6401	3125	6514	3070	6547	3055
6449	3101	6437	3107	6518	3068	6422	3114	6445	3103
6408	3121	6495	3079	6413	3119	6414	3118	6401	3125
6509	3073	6413	3119	6446	3103	6467	3093	6353	3148
6447	3102	6405	3123	6470	3091	6482	3085	6513	3071
6472	3090	6433	3109	6450	3101	6358	3146	6396	3127
6426	3112	6584	3038	6531	3062	6412	3119	6525	3065
Mean	3098		3094		3097		3111		3100
Ex Var	63		85		63		76		93
Std Dev	21		28		20		21		29

ACCURACY TEST

Date: 7 February 1968	Temperature	<u>Start</u>	<u>Finish</u>
Time: 0826 to 1048	Barometer	50F	46F
Range: 100 Yards	Relative Humidity:	30.02 in	30.00 in
		38%	53%

	Center of Impact							
Target	from Index Point							
<u>Number</u>	<u>X</u>	<u>Y</u>	<u>MR</u>	<u>MVD</u>	<u>MHD</u>	<u>EVD</u>	<u>EHD</u>	<u>ES</u>
<u>Rifle No. 843489(1)</u>			<u>Rounds Previously Fired in Rifle: 6147</u>					
			<u>Cartridge Lot: RA5244</u>					
1	+ 0.1	- 8.5	1.86	1.52	0.83	5.4	3.3	5.7
2	- 0.7	- 6.1	0.94	0.82	0.38	3.3	1.8	3.3
3	- 1.8	- 4.1	1.47	0.84	0.95	4.2	4.4	4.5
4	- 1.8	- 4.4	1.69	1.45	0.69	5.3	2.4	5.4
5	- 3.0	- 4.8	1.53	1.04	0.91	4.4	4.2	4.4
Average	- 1.4	- 5.6	1.50	1.13	0.75	4.5	3.2	4.7

	<u>Rifle No. 855603(4)</u>		<u>Rounds Previously Fired in Rifle: 6150</u>					
			<u>Cartridge Lot: TW18179</u>					
1	- 0.0	-2.2	1.52	0.96	1.00	4.1	6.0	6.4 ^a
2	- 0.7	-1.4	1.02	0.80	0.53	2.5	1.9	2.6
3	- 1.0	-0.6	0.96	0.83	0.41	3.1	1.6	3.2
4	- 1.6	0.0	0.89	0.49	0.62	2.2	3.4	3.4
5	- 2.1	-0.2	0.94	0.71	0.47	2.3	2.3	2.5
Average	- 1.3	-0.9	1.07	0.76	0.61	2.8	3.0	3.6

	<u>Rifle No. 859129(7)</u>		<u>Rounds Previously Fired in Rifle: 6149</u>					
			<u>Cartridge Lot: RA5320</u>					
1	- 1.2	- 9.0	1.31	0.65	0.90	3.0	5.2	5.2 ^b
2	+ 0.1	- 6.8	1.24	0.98	0.61	3.4	2.6	3.5
3	+ 0.1	- 5.8	1.15	0.89	0.62	2.8	2.1	3.2
4	- 1.4	- 7.2	1.08	0.72	0.66	2.6	3.0	3.5
5	- 2.5	- 5.3	1.12	0.76	0.70	2.7	2.0	3.1
Average	- 1.0	- 6.8	1.18	0.80	0.70	2.9	3.0	3.7

	<u>Rifle No. 862235(10)</u>		<u>Rounds Previously Fired in Rifle: 6150</u>					
			<u>Cartridge Lot: TW18191</u>					
1	+ 2.4	- 4.4	1.84	0.90	1.52	3.6	6.4	7.1 ^c
2	+ 0.1	- 2.5	0.73	0.55	0.38	2.1	1.9	2.5
3	+ 0.1	- 2.4	0.90	0.71	0.43	2.5	2.1	2.9
4	- 0.6	- 1.7	1.00	0.67	0.56	2.4	2.5	2.6
5	- 0.8	- 1.3	0.70	0.45	0.47	2.0	2.3	2.7
Average	+ 0.2	- 2.5	1.03	0.66	0.67	2.5	3.0	3.6

a 9 Shots in 3.7

b 9 Shots in 3.1

c 8 Shots in 3.7

VELOCITY DATA

Date: 7 February 1968

<u>Target 1</u>		<u>Target 2</u>		<u>Target 3</u>		<u>Target 4</u>		<u>Target 5</u>	
<u>Time</u>	<u>Velocity</u>	<u>Time</u>	<u>Velocity</u>	<u>Time</u>	<u>Velocity</u>	<u>Time</u>	<u>Velocity</u>	<u>Time</u>	<u>Velocity</u>
<u>Rifle 843489(1) and Cartridge Lot RA5244</u>						<u>Time: 0826 to 0852</u>			
6389	3130	6280	3185	6288	3181	6270	3190	6390	3130
6399	3125	6431	3110	6373	3138	6278	3186	6217	3217
6496	3079	6341	3154	6294	3178	6251	3199	6370	3140
6325	3162	6366	3142	6390	3130	6325	3162	6322	3164
6415	3118	6503	3076	6251	3199	6266	3192	6270	3190
6291	3179	6259	3195	6266	3192	6211	3220	6316	3167
6331	3159	6307	3171	6310	3170	6251	3199	6255	3197
6302	3174	6175	3239	6311	3169	6282	3184	6207	3222
6417	3117	6217	3217	6174	3239	6356	3147	6286	3182
6327	3161	6294	3178	6332	3159	6411	3120	6289	3180
Mean	3140		3167		3175		3180		3179
Ex Var	100		163		109		100		92
Std Dev	30		46		30		28		29
<u>Rifle 855603(4) and Cartridge Lot TW18179</u>						<u>Time: 0908 to 0924</u>			
6454	3099	6484	3085	6338	3156	6397	3126	6411	3120
6479	3087	6419	3116	6327	3161	6421	3115	6378	3136
6358	3146	6447	3102	6434	3108	6342	3154	6429	3111
6580	3040	6435	3108	6403	3124	6376	3137	6381	3134
6447	3102	6375	3137	6382	3134	6374	3138	6436	3108
6471	3091	6429	3111	6462	3095	6386	3132	6390	3130
6514	3070	6394	3128	6454	3099	6453	3099	6424	3113
6458	3097	6416	3117	6377	3136	6408	3121	6451	3100
6528	3064	6420	3115	6415	3118	6389	3130	6406	3122
6539	3059	6516	3069	6483	3085	6449	3101	6389	3130
Mean	3085		3109		3122		3125		3120
Ex Var	106		68		76		55		36
Std Dev	28		19		24		16		12

VELOCITY DATA

Date: 7 February 1968

<u>Target 1</u>		<u>Target 2</u>		<u>Target 3</u>		<u>Target 4</u>		<u>Target 5</u>	
<u>Time</u>	<u>Velocity</u>	<u>Time</u>	<u>Velocity</u>	<u>Time</u>	<u>Velocity</u>	<u>Time</u>	<u>Velocity</u>	<u>Time</u>	<u>Velocity</u>
<u>Rifle 859129(7) and Cartridge Lot RA5320</u>						<u>Time: 0947 to 1014</u>			
6333	3158	6217	3217	6223	3214	6208	3222	6244	3203
6326	3162	6234	3208	6209	3221	6272	3189	6242	3204
6237	3207	6242	3204	6234	3208	6230	3210	6243	3204
6343	3153	6231	3210	6284	3183	6324	3163	6192	3230
6283	3183	6226	3212	6302	3174	6316	3167	6168	3243
6240	3205	6226	3212	6232	3209	6259	3195	6238	3206
6288	3181	6210	3221	6251	3199	6240	3205	6223	3214
6288	3181	6236	3207	6232	3209	6244	3203	6283	3183
6223	3214	6238	3206	6264	3193	6269	3190	6264	3193
6243	3204	6231	3210	6243	3204	6265	3192	6240	3205
Mean	3185		3211		3201		3194		3208
Ex Var	61		17		47		59		60
Std Dev	21		5		14		17		16

<u>Rifle 862235(10) and Cartridge Lot TW18191</u>						<u>Time: 1025 to 1048</u>			
6436	3108	6484	3085	6415	3118	6462	3095	6455	3098
6457	3097	6451	3100	6524	3066	6384	3133	6459	3096
6495	3079	6467	3093	6426	3112	6502	3076	6518	3068
6558	3050	6421	3115	6417	3117	6396	3127	6500	3077
6457	3097	6559	3049	6414	3118	6348	3151	6392	3129
6469	3092	6469	3092	6461	3095	6451	3100	6493	3080
6473	3090	6433	3109	6438	3107	6439	3106	6445	3103
6372	3139	6440	3106	6541	3058	6445	3103	6427	3112
6436	3108	6445	3103	6418	3116	6477	3088	6531	3062
6453	3099	6484	3085	6509	3073	6373	3138	6449	3101
Mean	3096		3094		3098		3112		3093
Ex Var	89		66		60		75		67
Std Dev	21		18		23		23		20

ACCURACY TEST

Date: 9 February 1968
 Time: 0830 to 1045
 Range: 100 Yards

Temperature: Start 50F Finish 48F
 Barometer: 29.78 in 29.81 in
 Relative Humidity: 44% 55%

Target Number	Center of Impact from Index Point		MR	MVD	MHD	EVD	EHD	ES
	X	Y						
<u>Rifle No. 843489(1)</u>			<u>Rounds Previously Fired in Rifle: 8197</u>					
<u>Cartridge Lot: RA5244</u>								
1	- 0.1	-13.0	2.65	1.10	2.25	4.6	7.9	8.6
2	- 1.1	-11.8	1.75	1.32	1.06	4.6	3.6	5.2
3	- 2.7	- 7.2	1.08	0.65	0.73	3.1	2.3	3.3
4	- 3.7	- 7.0	0.90	0.41	0.73	1.9	2.5	2.5
5	- 4.2	- 6.6	0.90	0.65	0.49	3.0	1.7	3.1
Average	- 2.4	- 9.1	1.46	0.83	1.05	3.4	3.6	4.5

<u>Rifle No. 855603(4)</u>			<u>Rounds Previously Fired in Rifle: 8200</u>					
<u>Cartridge Lot: TW18179</u>								
1	- 1.7	+ 3.9	1.35	1.03	0.67	5.1	2.9	5.2 ^a
2	- 3.5	+ 5.4	1.13	0.75	0.74	3.0	3.4	4.3
3	- 4.0	+ 5.2	1.18	0.76	0.73	2.6	2.6	2.8
4	- 5.0	+ 6.1	1.32	0.70	0.97	2.5	3.8	4.2
5	- 5.4	+ 5.9	0.85	0.77	0.38	2.9	1.6	3.0
Average	- 3.9	+ 5.3	1.17	0.80	0.70	3.2	2.9	3.9

<u>Rifle No. 859129(7)</u>			<u>Rounds Previously Fired in Rifle: 8199</u>					
<u>Cartridge Lot: RA5320</u>								
1	- 1.9	- 7.2	1.50	1.00	1.02	3.6	4.9	5.9 ^b
2	+ 2.5	- 9.5	1.84	1.34	1.08	5.1	4.1	5.5
3	+ 4.7	- 8.2	1.18	0.98	0.45	4.4	1.9	4.4
4	+ 4.6	- 6.7	1.66	1.21	0.92	6.3	2.9	6.4
5	+ 4.1	- 3.8	1.92	1.35	1.03	5.1	3.5	5.1
Average	+ 2.8	- 7.1	1.62	1.18	0.90	4.9	3.5	5.5

<u>Rifle No. 862235(10)</u>			<u>Rounds Previously Fired in Rifle: 8200</u>					
<u>Cartridge Lot: TW18191</u>								
1	+ 4.3	- 2.9	1.76	1.31	1.01	4.9	3.5	5.3
2	+ 4.0	- 1.8	1.81	0.90	1.35	4.4	5.5	5.5
3	+ 4.1	- 1.5	1.16	0.61	0.96	2.3	4.2	4.2
4	+ 3.4	- 0.8	1.25	0.47	1.12	1.9	3.4	3.4
5	+ 3.4	- 0.9	1.27	0.62	1.02	2.1	3.8	4.4
Average	+ 3.8	- 1.6	1.45	0.78	1.09	3.1	4.1	4.6

a 9 Shots in 3.1

b 9 Shots in 3.0

VELOCITY DATA

Date: 9 February 1968

<u>Target 1</u>		<u>Target 2</u>		<u>Target 3</u>		<u>Target 4</u>		<u>Target 5</u>	
<u>Time</u>	<u>Velocity</u>	<u>Time</u>	<u>Velocity</u>	<u>Time</u>	<u>Velocity</u>	<u>Time</u>	<u>Velocity</u>	<u>Time</u>	<u>Velocity</u>
<u>Rifle 843489(1) and Cartridge Lot RA5244</u>						<u>Time: 0830 to 0900</u>			
6261	3196	6264	3193	6316	3167	6253	3198	6271	3189
6316	3167	6298	3176	6233	3209	6189	3232	6229	3211
6233	3209	6333	3158	6297	3176	6289	3180	6276	3187
6294	3178	6429	3111	6180	3236	6292	3179	6265	3192
6469	3092	6226	3212	6263	3193	6184	3234	6220	3215
6301	3174	6342	3154	6213	3219	6248	3201	6235	3208
6276	3187	6461	3095	6298	3176	6235	3208	6224	3213
6270	3190	6284	3183	6282	3184	6237	3207	6186	3233
6236	3207	6228	3211	6207	3222	6158	3248	6228	3211
6207	3222	6284	3183	6220	3215	6238	3206	6232	3209
Mean	3182		3168		3200		3209		3207
Ex Var	130		116		69		69		46
Std Dev	34		37		23		21		13

Rifle 855603(4) and Cartridge Lot TW18179

Time: 0910 to 0935

6422	3114	6475	3089	6394	3128	6344	3153	6515	3070
6442	3105	6498	3078	6460	3096	6454	3099	6412	3119
6483	3085	6392	3129	6584	3038	6494	3080	6334	3158
6442	3105	6398	3126	6408	3121	6387	3131	6449	3101
6404	3123	6481	3086	6463	3095	6395	3127	6411	3120
6455	3098	6477	3088	6412	3119	6612	3025	6408	3121
6459	3096	6434	3108	6497	3078	6433	3109	6490	3082
6548	3054	6359	3145	6470	3091	6536	3060	6440	3106
6385	3132	6532	3062	6448	3102	6432	3109	6435	3108
6418	3116	6474	3089	6427	3112	6439	3106	6540	3058
Mean	3103		3100		3098		3100		3104
Ex Var	78		83		90		128		100
Std Dev	21		25		25		35		27

VELOCITY DATA

Date: 9 February 1968

<u>Target 1</u>		<u>Target 2</u>		<u>Target 3</u>		<u>Target 4</u>		<u>Target 5</u>	
<u>Time</u>	<u>Velocity</u>	<u>Time</u>	<u>Velocity</u>	<u>Time</u>	<u>Velocity</u>	<u>Time</u>	<u>Velocity</u>	<u>Time</u>	<u>Velocity</u>
<u>Rifle 859129(7) and Cartridge Lot RA5320</u>						<u>Time: 0945 to 1010</u>			
6273	3188	6270	3190	6240	3205	6221	3215	6270	3190
6283	3183	6189	3232	6272	3189	6283	3183	6252	3199
6324	3163	6305	3172	6279	3185	6213	3219	6211	3220
6283	3183	6340	3155	6229	3211	6259	3195	6278	3186
6224	3213	6221	3215	6329	3160	6272	3189	6241	3205
6274	3188	6248	3201	6333	3158	6255	3197	6264	3193
6276	3187	6159	3247	6260	3195	6325	3162	6261	3194
6235	3208	6221	3215	6250	3200	6274	3188	6233	3209
6276	3187	6222	3214	6211	3220	6264	3193	6226	3212
6262	3194	6159	3247	6257	3196	6310	3170	6235	3208
Mean	3189		3209		3192		3191		3202
Ex Var	50		92		62		57		34
Std Dev	13		29		19		17		10

<u>Rifle 862235(10) and Cartridge Lot TW18191</u>						<u>Time: 1025 to 1045</u>			
6491	3081	6448	3102	6384	3133	6474	3089	6534	3061
6514	3070	6520	3067	6503	3076	6453	3099	6391	3129
6464	3094	6493	3080	6406	3122	6477	3088	6518	3068
6471	3091	6446	3103	6434	3108	6473	3090	6384	3133
6508	3073	6465	3094	6471	3091	6405	3123	6530	3063
6564	3047	6489	3082	6548	3054	6504	3075	6448	3102
6499	3077	6418	3116	6492	3081	6521	3067	6459	3096
6512	3071	6462	3095	6420	3115	6420	3115	6487	3083
6520	3067	6503	3076	6459	3096	6455	3098	6542	3057
6469	3092	6454	3099	6497	3078	6423	3114	6548	3054
Mean	3076		3091		3095		3096		3085
Ex Var	47		49		79		56		79
Std Dev	13		14		23		17		28

ACCURACY TEST

Date: 12 February 1968	Temperature: 44F	<u>Start</u> 44F	<u>Finish</u> 44F
Time: 0842 to 1108	Barometer: 29.80 in	29.80 in	29.80 in
Range: 100 Yards	Relative Humidity: 44%	44%	37%

Target Number	Center of Impact from Index Point		<u>MR</u>	<u>MVD</u>	<u>MHD</u>	<u>EVD</u>	<u>EHD</u>	<u>ES</u>
	<u>X</u>	<u>Y</u>						
Rifle No. 843489(1)			Rounds Previously Fired in Rifle: 10,247					
			Cartridge Lot: RA5244					
1	+ 2.0	-12.3	3.19	2.88	1.04	13.3	3.4	13.4 ^a
2	+ 2.0	- 8.2	1.96	1.25	1.36	4.0	5.0	5.9
3	+ 0.9	-10.1	0.95	0.51	0.71	2.2	2.5	3.3
4	+ 0.3	- 9.2	1.34	0.92	0.86	4.9	5.0	6.4 ^b
5	- 0.5	- 8.6	1.33	1.27	0.30	4.8	1.4	4.8
Average	+ 0.9	- 9.7	1.75	1.37	0.85	5.8	3.5	6.8

Rifle No. 855603(4)			Rounds Previously Fired in Rifle: 10,250					
			Cartridge Lot: TW18179					
1	- 0.3	+ 1.9	1.80	1.54	0.64	6.9	3.1	7.0 ^c
2	- 0.8	+ 2.7	1.09	0.56	0.87	2.0	3.7	4.2
3	- 1.1	+ 3.0	0.84	0.53	0.57	2.5	2.9	3.5
4	- 1.5	+ 3.7	1.66	1.00	1.08	5.4	3.9	5.9 ^d
5	- 1.4	+ 3.6	1.37	0.92	0.92	4.0	3.0	4.7
Average	- 1.0	+ 3.0	1.35	0.91	0.82	4.2	3.3	5.1

Rifle No. 859129(7)			Rounds Previously Fired in Rifle: 10,249					
			Cartridge Lot: RA5320					
1	+ 1.8	- 3.4	1.90	1.74	0.52	7.3	2.4	7.4 ^e
2	+ 1.6	- 2.7	1.64	1.31	0.73	5.7	3.1	6.0
3	+ 0.8	- 2.6	1.44	1.17	0.73	3.1	2.6	3.7
4	+ 0.9	- 2.1	0.70	0.42	0.52	1.4	1.5	1.8
5	+ 1.4	- 2.3	1.23	0.74	0.82	3.8	3.1	4.4
Average	+ 1.3	- 2.6	1.38	1.08	0.66	4.3	2.5	4.7

Rifle No. 862235(10)			Rounds Previously Fired in Rifle: 10,250					
			Cartridge Lot: TW18191					
1	+ 2.7	- 0.6	1.60	1.15	0.98	5.1	4.6	6.0 ^f
2	+ 3.6	- 0.1	1.52	0.84	1.08	3.0	5.5	5.5 ^g
3	+ 3.9	+ 1.4	1.65	1.09	0.91	5.1	4.1	5.2
4	+ 3.3	+ 2.5	1.63	1.19	0.91	5.2	3.9	5.5
5	+ 3.9	+ 2.7	1.84	1.44	1.01	5.0	3.0	5.6
Average	+ 3.5	+ 1.2	1.65	1.14	0.98	4.7	4.2	5.6

a 9 Shots in 10.9	b 9 Shots in 3.1	c 9 Shots in 4.0
d 9 Shots in 4.2	e 9 Shots in 5.1	f 9 Shots in 4.0
g 9 Shots in 3.3		

VELOCITY DATA

Date: 12 February 1968

<u>Target 1</u>		<u>Target 2</u>		<u>Target 3</u>		<u>Target 4</u>		<u>Target 5</u>	
<u>Time</u>	<u>Velocity</u>	<u>Time</u>	<u>Velocity</u>	<u>Time</u>	<u>Velocity</u>	<u>Time</u>	<u>Velocity</u>	<u>Time</u>	<u>Velocity</u>
<u>Rifle 843489(1) and Cartridge Lot RA5244</u>						<u>Time: 0842 to 0908</u>			
6416	3117	6242	3204	6370	3140	6323	3163	6305	3172
6343	3153	6365	3142	6464	3094	6331	3159	6275	3187
6416	3117	6358	3146	6304	3173	6302	3174	6281	3184
6402	3124	6415	3118	6389	3130	6253	3198	6306	3172
6305	3172	6345	3152	6337	3156	6312	3169	6262	3194
6265	3192	6392	3129	6332	3159	6310	3170	6308	3171
6498	3078	6367	3141	6299	3175	6332	3159	6237	3207
6393	3128	6324	3163	6263	3193	6254	3198	6302	3174
6315	3167	6361	3144	6265	3192	6325	3162	6307	3171
6352	3149	6311	3169	6308	3171	6216	3218	6279	3185
Mean	3140		3151		3158		3177		3182
Ex Var	114		86		99		59		36
Std Dev	32		23		29		19		11

<u>Rifle 855603(4) and Cartridge Lot TW18179</u>						<u>Time: 0922 to 0948</u>			
6611	3025	6477	3088	6481	3086	6467	3093	6557	3050
6593	3034	6504	3075	6613	3024	6649	3008	6575	3042
6527	3064	6506	3074	6529	3063	6488	3083	6502	3076
6559	3049	6479	3087	6539	3059	6532	3062	6545	3056
6589	3035	6569	3045	6493	3080	6455	3098	6611	3025
6600	3030	6585	3037	6572	3043	6470	3091	6454	3099
6604	3028	6562	3048	6504	3075	6561	3048	6563	3047
6460	3096	6525	3065	6537	3060	6571	3044	6643	3011
6502	3076	6632	3016	6519	3068	6507	3074	6556	3051
6456	3098	6562	3048	6543	3057	6542	3057	6616	3023
Mean	3054		3058		3061		3066		3048
Ex Var	73		72		62		90		88
Std Dev	27		22		17		26		25

VELOCITY DATA

Date: 12 February 1968

<u>Target 1</u>		<u>Target 2</u>		<u>Target 3</u>		<u>Target 4</u>		<u>Target 5</u>	
<u>Time</u>	<u>Velocity</u>	<u>Time</u>	<u>Velocity</u>	<u>Time</u>	<u>Velocity</u>	<u>Time</u>	<u>Velocity</u>	<u>Time</u>	<u>Velocity</u>
<u>Rifle 859129(7) and Cartridge Lot RA5320</u>						<u>Time: 1000 to 1028</u>			
6282	3184	6349	3150	6326	3162	6276	3187	6314	3168
6283	3183	6260	3195	6246	3202	6233	3209	6240	3205
6308	3171	6276	3187	6215	3218	6227	3212	6257	3196
6301	3174	6302	3174	6303	3173	6224	3213	6229	3211
6328	3161	6215	3218	6290	3180	6277	3186	6290	3180
6326	3162	6289	3180	6227	3212	6297	3176	6296	3177
6263	3193	6297	3176	6331	3159	6296	3177	6237	3207
6279	3185	6335	3157	6369	3140	6249	3201	6232	3209
6329	3160	6255	3197	6262	3194	6234	3208	6241	3205
6276	3187	6245	3203	6201	3225	6286	3182	6163	3245
Mean	3176		3184		3186		3195		3200
Ex Var	33		68		85		37		77
Std Dev	12		20		27		14		21

<u>Rifle 682235(10) and Cartridge Lot TW18191</u>						<u>Time: 1040 to 1108</u>			
6473	3090	6559	3049	6527	3064	6556	3051	6499	3077
6546	3055	6555	3051	6490	3082	6519	3068	6448	3102
6563	3047	6540	3058	6519	3068	6575	3042	6479	3087
6548	3054	6552	3053	6664	3001	6540	3058	6482	3085
6569	3045	6475	3089	6540	3058	6446	3103	6508	3073
6537	3060	6452	3100	6419	3116	6505	3075	6552	3053
6524	3066	6544	3056	6472	3090	6506	3074	6555	3051
6514	3070	6488	3083	6682	2993	6564	3047	6655	3005
6509	3073	6474	3089	6564	3047	6509	3073	6448	3102
6505	3075	6491	3081	6541	3058	6501	3076	6646	3009
Mean	3063		3071		3058		3067		3064
Ex Var	45		51		123		61		97
Std Dev	13		18		36		17		33

ACCURACY TEST

Date: 12 February 1968	Temperature: 44F	<u>Start</u>	<u>Finish</u>
Time: 1303 to 1630	Barometer: 29.79 in	44F	44F
Range: 100 Yards	Relative Humidity: 35%	29.79 in	29.76 in
		35%	35%

Target Number	Center of Impact from Index Point		MR	MVD	MHD	EVD	EHD	ES
	X	Y						
<u>Rifle No. 848305(2)</u>			<u>Rounds Previously Fired in Rifle: 0</u>					
			<u>Cartridge Lot: RA5244</u>					
1	- 2.2	-12.9	1.43	1.15	0.58	6.2	2.6	6.4 ^a
2	- 2.1	-12.2	1.28	1.06	0.42	3.5	2.4	3.6
3	- 3.0	-11.8	0.91	0.48	0.66	2.0	3.7	3.8
4	- 3.3	-10.8	0.92	0.55	0.64	2.2	2.8	2.8
5	- 4.4	-10.2	0.71	0.55	0.36	2.6	1.5	2.7
Average	- 3.0	-11.6	1.05	0.76	0.53	3.3	2.6	3.9

<u>Rifle No. 856133(5)</u>			<u>Rounds Previously Fired in Rifle: 0</u>					
			<u>Cartridge Lot: TW18179</u>					
1	- 7.5	-12.2	1.54	1.13	0.93	4.0	2.9	5.0
2	- 6.6	-12.3	0.77	0.52	0.46	2.0	2.2	2.5
3	- 6.6	-11.3	0.61	0.41	0.39	1.6	1.5	1.9
4	- 7.3	-10.5	0.84	0.65	0.36	2.7	1.9	2.8
5	- 7.9	- 9.7	0.72	0.49	0.45	2.1	1.4	2.5
Average	- 7.2	-11.2	0.90	0.64	0.52	2.5	2.0	2.9

<u>Rifle No. 859908(8)</u>			<u>Rounds Previously Fired in Rifle: 0</u>					
			<u>Cartridge Lot: RA5320</u>					
1	+ 1.3	- 6.9	1.87	1.73	0.52	8.0	2.4	8.0 ^b
2	+ 2.9	- 5.2	1.05	0.77	0.59	4.0	3.3	4.6
3	+ 2.9	- 3.7	1.21	0.81	0.66	3.5	3.6	3.8
4	+ 3.3	- 3.9	0.68	0.61	0.26	2.2	1.2	2.3
5	+ 3.9	- 2.5	1.04	0.72	0.64	2.9	1.9	3.0
Average	+ 2.9	- 4.4	1.17	0.93	0.53	4.1	2.5	4.3

<u>Rifle No. 863323(11)</u>			<u>Rounds Previously Fired in Rifle: 0</u>					
			<u>Cartridge Lot: TW18191</u>					
1	- 1.2	-10.2	1.45	1.19	0.63	6.4	2.0	6.5 ^c
2	- 2.0	- 8.8	1.05	0.64	0.73	2.8	3.6	3.9
3	- 2.7	- 8.5	1.32	1.07	0.73	4.8	4.2	6.0
4	- 3.0	- 8.2	1.06	0.64	0.66	2.5	3.3	3.7
5	- 2.7	- 8.1	1.00	0.65	0.60	2.8	2.5	3.2
Average	- 2.3	- 8.8	1.18	0.84	0.67	3.9	3.1	4.7

a 9 Shots in 2.7

b 9 Shots in 4.7

c 9 Shots in 2.8

VELOCITY DATA

Date: 12 February 1968

<u>Target 1</u>		<u>Target 2</u>		<u>Target 3</u>		<u>Target 4</u>		<u>Target 5</u>	
<u>Time</u>	<u>Velocity</u>	<u>Time</u>	<u>Velocity</u>	<u>Time</u>	<u>Velocity</u>	<u>Time</u>	<u>Velocity</u>	<u>Time</u>	<u>Velocity</u>
<u>Rifle 848305(2) and Cartridge Lot RA5244</u>						<u>Time: 1303 to 1332</u>			
6499	3077	6361	3144	6195	3228	6210	3221	6187	3233
6479	3087	6273	3188	6410	3120	6376	3137	6197	3227
6525	3065	6287	3181	6393	3128	6294	3178	6256	3197
6468	3092	6245	3203	6374	3138	6251	3199	6274	3188
6552	3053	6340	3155	6259	3195	6327	3161	6170	3241
6463	3095	6316	3167	6410	3120	6411	3120	6242	3204
6463	3095	6429	3111	6325	3162	6323	3163	6268	3191
6526	3065	6378	3136	6307	3171	6326	3162	6249	3201
6346	3152	6423	3114	6268	3191	6326	3162	6296	3177
6385	3132	6361	3144	6217	3217	6221	3215	6239	3206
Mean	3091		3154		3167		3172		3206
Ex Var	99		92		108		101		64
Std Dev	29		29		38		31		20

Rifle 856133(5) and Cartridge Lot TW18179

Time: 1350 to 1512

6391	3129	6444	3104	6335	3157	6339	3155	6476	3088
6331	3159	6424	3113	6445	3103	6282	3184	6388	3131
6351	3149	6491	3081	6392	3129	6412	3119	6364	3143
	*	6478	3087	6287	3181	6325	3162	6393	3128
	*	6433	3109	6407	3122	6277	3186	6340	3155
	*	6426	3112	6422	3114	6330	3160	6374	3138
	*	6345	3152	6338	3156	6345	3152	6394	3128
	*	6460	3096	6337	3156	6404	3123	6396	3127
	*	6510	3072	6375	3137	6441	3105	6318	3166
	*	6404	3123	6323	3163	6373	3138	6313	3168
Mean	3146		3105		3142		3148		3137
Ex Var	30		80		78		81		80
Std Dev	12		22		23		26		22

* Not Recorded

VELOCITY DATA

Date: 12 February 1968

<u>Target 1</u>		<u>Target 2</u>		<u>Target 3</u>		<u>Target 4</u>		<u>Target 5</u>	
<u>Time</u>	<u>Velocity</u>	<u>Time</u>	<u>Velocity</u>	<u>Time</u>	<u>Velocity</u>	<u>Time</u>	<u>Velocity</u>	<u>Time</u>	<u>Velocity</u>
Rifle 859908(8)		and Cartridge Lot RA5320				Time: 1520 to 1548			
6266	3192	6234	3208	6225	3213	6196	3228	6192	3230
6375	3137	6245	3203	6200	3226	6253	3198	6203	3224
6280	3185	6331	3159	6293	3178	6238	3206	6225	3213
6258	3196	6245	3203	6215	3218	6238	3206	6215	3218
6270	3190	6318	3166	6236	3207	6200	3226	6136	3259
6317	3166	6276	3187	6218	3216	6199	3226	6168	3243
6244	3203	6242	3204	6247	3202	6189	3232	6251	3199
6239	3206	6328	3161	6220	3215	6185	3234	6151	3252
6280	3185	6229	3211	6178	3237	6260	3195	6209	3221
6304	3173	6250	3200	6241	3205	6290	3180	6222	3214
Mean	3183		3190		3212		3213		3227
Ex Var	69		52		59		54		60
Std Dev	19		20		15		18		18

<u>Rifle 863323(11) and Cartridge Lot TW18191</u>						<u>Time: 1600 to 1630</u>			
6382	3134	6373	3138	6430	3110	6392	3129	6365	3142
6415	3118	6428	3111	6421	3115	6399	3125	6337	3156
6469	3092	6386	3132	6435	3108	6440	3106	6446	3103
6446	3103	6526	3065	6524	3066	6326	3162	6539	3059
6420	3115	6421	3115	6399	3125	6448	3102	6394	3128
6479	3087	6401	3125	6446	3103	6396	3127	6392	3129
6424	3113	6488	3083	6489	3082	6395	3127	6368	3141
6517	3069	6463	3095	6396	3127	6410	3120	6385	3132
6353	3148	6360	3145	6431	3110	6452	3100	6454	3099
6576	3041	6383	3133	6419	3116	6439	3106	6417	3117
Mean	3102		3114		3106		3102		3102
Ex Var	107		80		61		62		57
Std Dev	30		25		18		18		27

ACCURACY TEST

Date: 14 February 1968	Temperature: <u>Start</u> 45F	<u>Finish</u> 40F
Time: 0830 to 1103	Barometer: 29.97 in	29.96 in
Range: 100 Yards	Relative Humidity: 44%	52%

Target Number	Center of Impact from Index Point		MR	MVD	MHD	EVD	EHD	ES
	X	Y						
<u>Rifle No. 848305(2)</u>			<u>Rounds Previously Fired in Rifle: 2050</u>					
<u>Cartridge Lot: RA5244</u>								
1	- 0.3	-14.5	1.36	0.94	0.91	4.5	3.5	4.7
2	- 1.4	-14.4	1.24	0.61	0.93	2.2	5.5	5.5
3	- 1.4	-14.1	1.33	0.98	0.68	4.6	2.3	4.7
4	- 1.4	-12.3	0.71	0.41	0.47	1.6	2.0	2.4
5	- 0.5	-12.3	0.88	0.58	0.59	2.2	2.8	2.9
Average	- 1.0	-13.5	1.10	0.70	0.72	3.0	3.2	4.0

<u>Rifle No. 856133(5)</u>			<u>Rounds Previously Fired in Rifle: 2050</u>					
<u>Cartridge Lot: TW18179</u>								
1	- 2.0	- 3.5	1.68	1.41	0.81	7.8	2.4	7.8 ^a
2	- 2.2	- 2.2	0.86	0.54	0.57	1.9	2.5	2.6
3	- 2.8	- 1.3	0.84	0.55	0.50	2.2	2.4	2.6
4	- 3.2	- 1.2	0.89	0.70	0.46	2.6	1.8	2.6
5	- 2.8	- 1.0	1.31	0.64	1.03	3.3	4.5	4.7
Average	- 2.6	- 1.8	1.12	0.77	0.67	3.6	2.7	4.1

<u>Rifle No. 859908(8)</u>			<u>Rounds Previously Fired in Rifle: 2050</u>					
<u>Cartridge Lot: RA5320</u>								
1	+ 2.7	- 8.2	1.93	1.73	0.67	7.3	3.0	7.7 ^b
2	+ 4.7	- 7.2	0.92	0.50	0.67	2.5	2.3	3.2
3	+ 3.5	- 5.1	1.89	1.27	1.20	4.7	4.8	6.2
4	+ 3.9	- 6.2	1.30	0.89	0.77	4.1	2.5	4.2 ^c
5	+ 3.7	- 5.3	0.83	0.48	0.64	2.2	3.1	3.4 ^c
Average	+ 3.7	- 6.4	1.37	0.97	0.79	4.2	3.1	4.9

<u>Rifle No. 863323(11)</u>			<u>Rounds Previously Fired in Rifle: 2050</u>					
<u>Cartridge Lot: TW18191</u>								
1	- 2.4	-16.2	2.37	2.15	0.87	9.1	3.3	9.1 ^d
2	- 2.0	-14.7	1.44	1.05	0.90	6.8	5.0	8.2 ^e
3	- 1.7	-14.6	1.23	0.83	0.75	3.6	3.6	4.3
4	- 2.1	-14.3	1.57	1.12	0.90	5.5	3.1	5.7
5	- 1.6	-13.9	1.00	0.58	0.74	2.7	2.4	3.5
Average	- 2.0	-14.7	1.52	1.15	0.83	5.5	3.5	6.2

a 9 Shots in 3.1 b 9 Shots in 4.4 c 9 Shots in 1.9
d 9 Shots in 7.0 e 9 Shots in 3.0

VELOCITY DATA

Date: 14 February 1968

<u>Target 1</u>		<u>Target 2</u>		<u>Target 3</u>		<u>Target 4</u>		<u>Target 5</u>	
<u>Time</u>	<u>Velocity</u>	<u>Time</u>	<u>Velocity</u>	<u>Time</u>	<u>Velocity</u>	<u>Time</u>	<u>Velocity</u>	<u>Time</u>	<u>Velocity</u>
<u>Rifle 848305(2) and Cartridge Lot RA5244</u>						<u>Time: 0830 to 0900</u>			
6240	3205	6244	3203	6263	3193	6289	3180	6254	3198
6265	3192	6232	3209	6124	3266	6151	3252	6156	3249
6242	3204	6163	3245	6230	3210	6162	3246	6255	3197
6355	3147	6244	3203	6271	3189	6130	3263	6227	3212
6273	3188	6291	3179	6214	3219	6268	3191	6263	3193
6278	3186	6266	3192	6233	3209	6181	3236	6187	3233
6272	3189	6292	3179	6208	3222	6248	3201	6334	3158
6243	3204	6260	3195	6214	3219	6207	3222	6194	3229
6354	3148	6174	3239	6324	3163	6219	3216	6152	3251
6226	3212	6261	3194	6233	3209	6204	3224	6186	3233
Mean	3188		3204		3210		3223		3215
Ex Var	65		66		103		83		93
Std Dev	22		21		25		25		28

Rifle 856133(5) and Cartridge Lot TW18179

Time: 0913 to 0938

6401	3125	6364	3143	6303	3173	6334	3158	6324	3163
6339	3155	6363	3143	6250	3200	6455	3098	6330	3160
6363	3143	6346	3152	6369	3140	6323	3163	6329	3160
6271	3189	6463	3095	6333	3158	6379	3135	6346	3152
6425	3113	6405	3123	6282	3184	6362	3144	6302	3174
6352	3149	6345	3152	6369	3140	6351	3149	6296	3177
6327	3161	6298	3176	6407	3122	6343	3153	6327	3161
6368	3141	6262	3194	6273	3188	6282	3184	6379	3135
6368	3141	6255	3197	6352	3149	6346	3152	6332	3159
6344	3153	6359	3145	6393	3128	6373	3138	6378	3136
Mean	3147		3152		3158		3147		3157
Ex Var	76		102		78		86		42
Std Dev	20		30		25		21		13

VELOCITY DATA

Date: 14 February 1968

<u>Target 1</u>		<u>Target 2</u>		<u>Target 3</u>		<u>Target 4</u>		<u>Target 5</u>	
<u>Time</u>	<u>Velocity</u>	<u>Time</u>	<u>Velocity</u>	<u>Time</u>	<u>Velocity</u>	<u>Time</u>	<u>Velocity</u>	<u>Time</u>	<u>Velocity</u>
Rifle 859908(8) and Cartridge Lot RA5320						Time: 0953 to 1025			
6247	3202	6204	3224	6176	3238	6398	3126	6211	3220
6210	3221	6211	3220	6221	3215	6213	3219	6201	3225
6266	3192	6261	3194	6206	3223	6213	3219	6165	3244
6272	3189	6195	3228	6222	3214	6242	3204	6278	3186
6147	3254	6214	3219	6165	3244	6255	3197	6214	3219
6184	3234	6223	6214	6165	3244	6338	3156	6192	3230
6199	3226	6177	3238	6233	3209	6230	3210	6183	3235
6175	3239	6265	3192	6179	3237	6159	3247	6212	3220
6279	3185	6211	3220	6229	3211	6160	3247	6223	3214
6303	3173	6182	3235	6162	3246	6173	3240	6192	3230
Mean	3211		3218		3228		3207		3222
Ex Var	81		46		37		121		58
Std Dev	26		14		14		37		15

Rifle 863323(11) and Cartridge Lot TW18191

Time: 1037 to 1103

	*	6372	3139	6374	3138	6472	3090	6326	3162
6368	3141	6405	3123	6347	3151	6442	3105	6266	3192
6340	3155	6398	3126	6334	3158	6285	3182	6474	3089
6358	3146	6389	3130	6492	3081	6382	3134	6429	3111
6406	3122	6353	3148	6364	3143	6384	3133	6416	3117
6294	3178	6388	3131	6355	3147	6397	3126	6322	3164
6404	3123	6388	3131	6402	3124	6363	3143	6325	3162
6362	3144	6314	3168	6389	3130	6400	3125	6372	3139
6399	3125	6386	3132	6424	3113	6304	3173	6351	3149
6334	3158	6367	3141	6389	3130	6412	3119	6330	3160
Mean	3143		3137		3132		3133		3144
Ex Var	56		45		77		92		103
Std Dev	17		12		21		27		29

* Not Recorded

ACCURACY TEST

Date: 16 February 1968	Temperature: <u>49F</u>	<u>Start</u>	<u>Finish</u>
Time: 0830 to 1052	Barometer: 29.96 in	49F	47F
Range: 100 Yards	Relative Humidity: 55%	29.96 in	29.95 in

	<u>Center of Impact</u>							
<u>Target</u>	<u>from Index Point</u>							
<u>Number</u>	<u>X</u>	<u>Y</u>	<u>MR</u>	<u>MVD</u>	<u>MHD</u>	<u>EVD</u>	<u>EHD</u>	<u>ES</u>
<u>Rifle No. 848305(2)</u>			<u>Rounds Previously Fired in Rifle: 4100</u>					
	<u>Cartridge Lot: RA5244</u>							

1	- 5.0	-15.4	1.87	1.75	0.48	7.9	1.6	8.0 ^a
2	- 2.8	-17.4	0.89	0.52	0.55	3.0	2.8	3.0
3	- 2.7	-18.1	0.90	0.61	0.56	2.9	2.2	3.0
4	- 4.5	-16.6	1.47	1.11	0.83	3.9	3.2	4.9
5	- 5.9	-15.7	1.53	0.98	1.05	3.6	3.5	4.3
Average	- 4.2	-16.6	1.33	0.99	0.69	4.3	2.7	4.6

<u>Rifle No. 856133(5)</u>	<u>Rounds Previously Fired in Rifle: 4100</u>							
	<u>Cartridge Lot: TW18179</u>							

1	- 3.1	- 9.1	1.71	1.46	0.67	8.4	2.4	8.5 ^b
2	- 2.8	- 7.1	0.95	0.72	0.43	3.4	2.3	3.7 ^c
3	- 3.6	- 6.0	1.98	1.44	1.24	6.9	6.4	9.3 ^c
4	- 3.3	- 6.6	0.87	0.54	0.59	2.3	2.6	2.9
5	- 2.2	- 6.7	0.71	0.52	0.39	2.3	1.7	2.4
Average	- 3.0	- 7.1	1.24	0.94	0.66	4.7	3.1	5.4

<u>Rifle 859908(8)</u>	<u>Rounds Previously Fired in Rifle: 4100</u>							
	<u>Cartridge Lot: RA5320</u>							

1	+ 2.9	- 8.6	1.48	1.15	0.55	6.6	2.9	6.7 ^d
2	+ 4.0	- 7.1	1.56	1.34	0.73	3.5	2.2	4.0
3	+ 3.6	- 6.5	1.40	1.26	0.56	5.2	2.8	5.5
4	+ 3.6	- 6.5	1.62	1.29	0.58	4.8	2.2	4.9
5	+ 4.7	- 5.9	0.82	0.60	0.49	1.9	1.9	2.5
Average	+ 3.8	- 6.9	1.38	1.13	0.58	4.4	2.4	4.7

<u>Rifle 863323(11)</u>	<u>Rounds Previously Fired in Rifle: 4100</u>							
	<u>Cartridge Lot: TW18191</u>							

1	+ 1.0	-11.2	1.44	0.95	0.98	5.6	4.7	7.0 ^c
2	+ 1.2	-11.0	1.06	0.52	0.76	2.7	2.8	2.9
3	+ 0.7	-10.0	1.35	0.87	0.88	4.1	3.9	4.3
4	+ 0.5	-10.1	1.15	0.69	0.78	2.6	3.0	3.9
5	+ 0.2	- 9.0	1.53	0.79	1.22	4.5	5.9	7.0
Average	+ 0.7	-10.3	1.31	0.76	0.92	3.9	4.1	5.0

a 9 Shots in 4.8	b 9 Shots in 2.2	c 9 Shots in 3.6
d 9 Shots in 3.4	e 9 Shots in 2.6	

VELOCITY DATA

Date: 16 February 1968

<u>Target 1</u>		<u>Target 2</u>		<u>Target 3</u>		<u>Target 4</u>		<u>Target 5</u>	
<u>Time</u>	<u>Velocity</u>	<u>Time</u>	<u>Velocity</u>	<u>Time</u>	<u>Velocity</u>	<u>Time</u>	<u>Velocity</u>	<u>Time</u>	<u>Velocity</u>
<u>Rifle 848305(2) and Cartridge Lot RA5244</u>						<u>Time: 0830 to 0854</u>			
6380	3135	6368	3141	6253	3198	6269	3190	6251	3199
6264	3193	6356	3147	6293	3178	6285	3182	6190	3231
6297	3176	6328	3161	6378	3136	6242	3204	6221	3215
6347	3151	6328	3161	6417	3117	6339	3155	6226	3212
6299	3175	6329	3160	6291	3179	6310	3170	6245	3203
6372	3139	6287	3181	6266	3192	6322	3164	6248	3201
6374	3138	6270	3190	6286	3182	6361	3144	6294	3178
6433	3109	6255	3197	6262	3194	6288	3181	6226	3212
6390	3130	6217	3217	6220	3215	6192	3230	6302	3174
6391	3129	6313	3168	6202	3225	3187	3233	6315	3167
Mean	3147		3172		3182		3185		3199
Ex Var	84		76		108		87		64
Std Dev	25		23		31		28		19

Rifle 856133(5) and Cartridge Lot TW18179

Time: 0910 to 0935

6367	3141	6309	3170	6374	3138	6276	3187	6336	3157
6353	3148	6446	3103	6318	3166	6365	3142	6395	3127
6342	3154	6374	3138	6401	3125	6240	3205	6376	3137
6409	3121	6413	3119	6411	3120	6477	3088	6431	3110
6377	3136	6368	3141	6461	3095	6333	3158	6311	3169
6414	3118	6503	3076	6512	3071	6294	3178	6404	3123
6337	3156	6375	3137	6419	3116	6428	3111	6378	3136
6327	3161	6415	3118	6403	3124	6394	3128	6322	3164
6441	3105	6395	3127	6407	3122	6489	3082	6334	3158
6387	3131	6359	3145	6373	3138	6305	3172	6358	3146
Mean	3137		3127		3121		3145		3143
Ex Var	56		94		95		123		59
Std Dev	17		24		24		40		18

VELOCITY DATA

Date: 16 February 1968

<u>Target 1</u>		<u>Target 2</u>		<u>Target 3</u>		<u>Target 4</u>		<u>Target 5</u>	
<u>Time</u>	<u>Velocity</u>	<u>Time</u>	<u>Velocity</u>	<u>Time</u>	<u>Velocity</u>	<u>Time</u>	<u>Velocity</u>	<u>Time</u>	<u>Velocity</u>
<u>Rifle 859908(8) and Cartridge Lot RA5320</u>						<u>Time: 0950 to 1018</u>			
6172	3240	6267	3191	6291	3179	6254	3198	6233	3209
6248	3201	6218	3216	6287	3181	6165	3244	6238	3206
6214	3219	6235	3208	6261	3194	6220	3215	6269	3190
6253	3198	6271	3189	6351	3149	6279	3185	6296	3177
6272	3189	6305	3172	6190	3231	6159	3247	6264	3193
6303	3173	6254	3198	6230	3210	6336	3157	6285	3182
6288	3181	6261	3194	6219	3216	6204	3224	6299	3175
6333	3158	6245	3203	6216	3218	6210	3221	6362	3144
6328	3161	6250	3200	6308	3171	6175	3239	6224	3213
6280	3185	6225	3213	6238	3206	6246	3202	6310	3170
Mean	3190		3198		3196		3213		3186
Ex Var	82		44		82		90		69
Std Dev	24		12		24		27		20

<u>Rifle 863323(11) and Cartridge Lot TW18191</u>						<u>Time: 1028 to 1052</u>			
6481	3086	6419	3116	6378	3136	6392	3129	6399	3125
6475	3089	6384	3133	6454	3099	6462	3095	6366	3142
6416	3117	6323	3163	6433	3109	6395	3127	6463	3095
6499	3077	6337	3156	6442	3105	6402	3124	6372	3139
6474	3089	6343	3153	6531	3062	6415	3118	6395	3127
6422	3114	6389	3130	6387	3131	6427	3112	6403	3124
6495	3079	6434	3108	6423	3114	6471	3091	6398	3126
6387	3131	6369	3140	6424	3113	6422	3114	6440	3106
6541	3058	6385	3132	6435	3108	6494	3080	6484	3085
6517	3069	6486	3084	6390	3130	6348	3151	6378	3136
Mean	3091		3132		3111		3114		3120
Ex Var	73		79		74		71		57
Std Dev	22		23		20		20		18

ACCURACY TEST

Date: 19 February 1968	Temperature: 49F	<u>Start</u> 49F	<u>Finish</u> 48F
Time: 0830 to 1105	Barometer 29.99 in	29.99 in	29.96 in
Range: 100 Yards	Relative Humidity: 38%	38%	36%

Target Number	Center of Impact from Index Point		MR	MVD	MHD	EVD	EHD	ES
	X	Y						
<u>Rifle No. 848305(2)</u>			<u>Rounds Previously Fired in Rifle: 6150</u>					
			<u>Cartridge Lot: RA5244</u>					
1	- 0.9	- 7.4	2.22	2.00	0.74	9.2	3.4	9.4 ^a
2	- 0.3	- 5.2	1.27	0.84	0.84	3.8	3.0	4.5
3	- 1.2	- 3.5	1.46	1.17	0.76	4.5	2.8	4.8
4	- 0.8	- 3.7	1.77	1.41	0.83	5.1	3.0	5.4
5	- 2.8	- 4.9	1.94	1.60	0.89	6.2	2.9	6.2
Average	- 1.2	- 4.9	1.73	1.40	0.81	5.8	3.0	6.1

<u>Rifle No. 856133(5)</u>			<u>Rounds Previously Fired in Rifle: 6150</u>					
			<u>Cartridge Lot: TW18179</u>					
1	- 2.1	- 8.0	2.45	2.17	0.89	11.7	3.3	12.0 ^b
2	- 1.0	- 5.5	1.38	1.05	0.69	4.7	4.0	5.3
3	- 1.0	- 5.6	1.11	0.68	0.78	2.9	2.7	3.5
4	- 0.5	- 5.1	1.63	1.28	0.94	5.8	4.6	7.4
5	- 1.0	- 5.3	1.16	0.72	0.83	3.8	4.2	5.3
Average	- 1.1	- 5.9	1.55	1.18	0.83	5.8	3.8	6.7

<u>Rifle No. 859908(8)</u>			<u>Rounds Previously Fired in Rifle: 6150</u>					
			<u>Cartridge Lot: RA5320</u>					
1	+ 3.6	-15.4	1.77	1.35	1.01	6.5	3.8	6.9 ^c
2	+ 5.0	-12.2	2.20	1.41	1.49	6.3	8.2	9.7 ^e
3	+ 8.1	-12.1	1.70	1.17	1.00	4.2	4.8	5.6
4	+ 7.4	-11.8	0.68	0.56	0.32	2.6	1.3	2.7
5	+ 6.6	-11.8	0.86	0.62	0.54	2.4	2.0	2.8
Average	+ 6.1	-12.7	1.44	1.02	0.87	4.4	4.0	5.5

<u>Rifle No. 863323(11)</u>			<u>Rounds Previously Fired in Rifle: 6150</u>					
			<u>Cartridge Lot: TW18191</u>					
1	+ 1.7	-10.7	2.45	1.63	1.46	9.6	5.5	10.1 ^d
2	+ 1.4	- 8.7	1.03	0.80	0.61	3.0	2.7	4.0
3	+ 2.0	- 7.6	1.36	0.81	1.03	3.0	3.3	3.9
4	+ 2.0	- 7.5	1.17	0.60	0.83	2.9	3.0	3.4
5	+ 1.6	- 6.4	1.04	0.64	0.74	2.7	2.7	3.7
Average	+ 1.7	- 8.2	1.41	0.90	0.93	4.2	3.4	5.0

a 9 Shots in 6.3 b 9 Shots in 7.3 c 9 Shots in 4.2
d 9 Shots in 5.6 e 9 Shots in 4.8

VELOCITY DATA

Date: 19 February 1968

<u>Target 1</u>		<u>Target 2</u>		<u>Target 3</u>		<u>Target 4</u>		<u>Target 5</u>	
<u>Time</u>	<u>Velocity</u>	<u>Time</u>	<u>Velocity</u>	<u>Time</u>	<u>Velocity</u>	<u>Time</u>	<u>Velocity</u>	<u>Time</u>	<u>Velocity</u>
<u>Rifle 848305(2) and Cartridge Lot RA5244</u>									
<u>Time: 0830 to 0900</u>									
6345	3152	6300	3175	6245	3203	6256	3197	6230	3210
6363	3143	6396	3127	6378	3136	6280	3185	6313	3168
6413	3119	6307	3171	6351	3149	6352	3149	6235	3208
6276	3187	6395	3127	6204	3224	6226	3212	6236	3207
6382	3134	6323	3163	6287	3181	6194	3229	6218	3216
6302	3174	6354	3148	6350	3150	6263	3193	6180	3236
6267	3191	6204	3224	6329	3160	6271	3189	6227	3212
6285	3182	6411	3120	6312	3169	6254	3198	6286	3182
6269	3190	6340	3155	6328	3161	6247	3202	6244	3203
6301	3174	6246	3202	6318	3166	6242	3204	6286	3182
Mean	3165		3161		3170		3196		3202
Ex Var	72		104		88		80		68
Std Dev	25		32		25		20		19

Rifle 856133(5) and Cartridge Lot TW18179

Time: 0910 to 1940

6247	3202	6405	3123	6543	3057	6404	3123	6377	3136
6460	3096	6441	3105	6499	3077	6369	3140	6295	3177
6371	3139	6403	3124	6423	3114	6410	3120	6470	3091
6330	3160	6326	3162	6358	3146	6375	3138	6371	3139
6433	3109	6366	3142	6365	3142	6465	3094	6479	3087
6500	3077	6421	3115	6378	3136	6367	3141	6388	3131
6344	3153	6442	3105	6365	3142	6338	3156	6375	3137
6392	3129	6403	3124	6342	3154	6398	3126	6468	3092
6415	3118	6467	3093	6456	3098	6451	3100	6341	3154
6427	3112	6450	3101	6503	3076	6541	3058	6324	3163
Mean	3129		3119		3114		3119		3131
Ex Var	125		69		97		98		90
Std Dev	34		20		33		27		30

VELOCITY DATA

Date: 19 February 1968

<u>Target 1</u>		<u>Target 2</u>		<u>Target 3</u>		<u>Target 4</u>		<u>Target 5</u>	
<u>Time</u>	<u>Velocity</u>	<u>Time</u>	<u>Velocity</u>	<u>Time</u>	<u>Velocity</u>	<u>Time</u>	<u>Velocity</u>	<u>Time</u>	<u>Velocity</u>
Rifle 859908(8) and Cartridge Lot RA 5320						Time: 0950 to 1025			
6327	3161	6213	3219	6229	3211	6223	3214	6176	3238
6291	3179	6311	3169	6282	3184	6199	3226	6240	3205
6197	3227	6282	3184	6323	3163	6250	3200	6215	3218
6303	3173	6255	3197	6194	3229	6219	3216	6205	3223
6221	3215	6294	3178	6166	3244	6206	3223	6231	3210
6267	3191	6245	3203	6201	3225	6214	3219	6197	3227
6236	3207	6259	3195	6193	3229	6229	3211	6222	3214
6250	3200	6273	3188	6216	3218	6238	3206	6192	3230
6198	3227	6251	3199	6240	3205	6220	3215	6236	3207
6274	3188	6190	3231	6261	3194	6227	3212	6204	3224
Mean	3197		3196		3210		3214		3220
Ex Var	66		62		81		26		33
Std Dev	21		18		23		7		10

<u>Rifle 863323(11) and Cartridge Lot TW18191</u>						<u>Time: 1035 to 1105</u>			
6402	3124	6441	3105	6446	3103	6380	3135	6396	3127
6441	3105	6408	3121	6472	3090	6425	3113	6389	3130
6460	3096	6304	3173	6508	3073	6415	3118	6455	3098
6404	3123	6470	3091	6467	3093	6438	3107	6460	3096
6410	3120	6433	3109	6376	3137	6428	3111	6440	3106
6412	3119	6500	3077	6453	3099	6403	3124	6565	3046
6491	3081	6421	3115	6445	3103	6430	3110	6356	3147
6427	3112	6462	3095	6388	3131	6474	3089	6470	3091
6460	3096	6396	3128	6400	3125	6473	3090	6479	3087
6397	3126	6462	3095	6440	3106	6404	3123	6482	3085
Mean	3110		3111		3106		3112		3101
Ex Var	45		96		64		46		101
Std Dev	14		25		19		14		27

ACCURACY TEST

Date: 21 February 1968
 Time: 0845 to 1110
 Range: 100 Yards

Temperature:
 Barometer:
 Relative Humidity:

<u>Start</u>	<u>Finish</u>
45F	41F
29.73 in	29.80 in
32%	38%

Target Number	Center of Impact from Index Point		MR	MVD	MHD	EVD	EHD	ES
	X	Y						
<u>Rifle No. 848305(2)</u>			<u>Rounds Previously Fired in Rifle: 8200</u>					
			<u>Cartridge Lot: RA5244</u>					
1	- 3.1	- 8.8	1.86	0.77	1.53	4.3	5.3	5.5
2	- 4.5	- 5.6	2.34	1.82	1.29	7.4	4.4	8.6
3	- 1.8	- 7.5	1.48	1.04	0.90	3.9	2.5	4.3
4	- 1.1	- 7.0	0.94	0.71	0.46	3.5	2.4	4.0 ^a
5	- 0.6	- 7.7	1.20	0.91	0.59	4.2	2.7	4.4
Average	- 2.2	- 7.3	1.56	1.05	0.95	4.7	3.5	5.4

<u>Rifle No. 856133(5)</u>			<u>Rounds Previously Fired in Rifle: 8200</u>					
			<u>Cartridge Lot: TW18179</u>					
1	- 8.4	- 5.7	2.08	1.91	0.45	10.0	1.7	10.1 ^b
2	- 7.3	- 4.4	1.01	0.67	0.63	2.6	3.6	3.8
3	- 8.6	- 4.1	1.65	1.20	0.99	5.6	4.8	6.9
4	- 7.8	- 4.9	1.52	1.03	1.00	4.5	3.9	4.7
5	- 7.5	- 5.0	1.13	0.60	0.77	3.5	4.0	4.1
Average	- 7.9	- 4.8	1.48	1.08	0.77	5.2	3.6	5.9

<u>Rifle No. 859908(8)</u>			<u>Rounds Previously Fired in Rifle: 8200</u>					
			<u>Cartridge Lot: RA5320</u>					
1	+ 5.8	- 5.9	2.36	1.76	1.45	9.0	6.7	11.0 ^c
2	+ 6.2	- 3.1	1.72	1.15	1.16	4.6	4.7	6.4 ^d
3	+ 6.1	- 3.0	1.20	0.69	0.80	2.5	3.6	3.6
4	+ 6.2	- 1.6	1.70	1.08	1.15	4.7	5.0	6.2
5	+ 6.1	- 2.1	0.91	0.56	0.61	1.8	2.5	2.6
Average	+ 6.1	- 3.1	1.58	1.05	1.03	4.5	4.5	6.0

<u>Rifle No. 863323(11)</u>			<u>Rounds Previously Fired in Rifle: 8200</u>					
			<u>Cartridge Lot: TW18191</u>					
1	- 3.9	-10.5	2.39	1.83	1.28	7.3	5.1	7.9
2	- 2.8	-10.2	1.48	0.70	1.20	2.3	4.2	4.3
3	- 3.1	- 9.1	1.16	0.91	0.57	3.6	2.3	3.6
4	- 2.7	- 7.9	1.46	0.99	0.82	4.1	3.8	4.2
5	- 3.2	- 7.4	1.08	0.73	0.63	2.8	2.2	3.1
Average	- 3.1	- 9.0	1.51	1.03	0.90	4.0	3.5	4.6

a 9 Shots in 1.9
 d 9 Shots in 3.9

b 9 Shots in 6.3

c 9 Shots in 5.1

VELOCITY DATA

Date: 21 February 1968

<u>Target 1</u>		<u>Target 2</u>		<u>Target 3</u>		<u>Target 4</u>		<u>Target 5</u>	
<u>Time</u>	<u>Velocity</u>	<u>Time</u>	<u>Velocity</u>	<u>Time</u>	<u>Velocity</u>	<u>Time</u>	<u>Velocity</u>	<u>Time</u>	<u>Velocity</u>
<u>Rifle 848305(2) and Cartridge Lot RA5244</u>									
<u>Time: 0845 to 0915</u>									
6317	3166	6296	3177	6270	3190	6333	3158	6236	3207
6392	3129	6482	3085	6375	3137	6308	3171	6282	3184
6304	3173	6338	3156	6307	3171	6246	3202	6290	3180
6322	3164	6414	3118	6271	3189	6263	3193	6335	3157
6435	3108	6272	3189	6339	3155	6346	3152	6268	3191
6346	3152	6371	3139	6395	3127	6294	3178	6280	3185
6541	3058	6298	3176	6286	3182	6263	3193	6308	3171
6355	3147	6338	3156	6240	3205	6316	3167	6276	3187
6398	3126	6412	3119	6273	3188	6218	3216	6288	3181
6443	3104	6405	3123	6339	3155	6311	3169	6360	3145
Mean	3133		3144		3170		3180		3179
Ex Var	115		104		78		64		62
Std Dev	34		31		24		20		17

<u>Rifle 856133(5) and Cartridge Lot TW18179</u>						<u>Time: 0925 to 0950</u>			
6400	3125	6469	3092	6466	3093	6457	3097	6519	3068
6424	3113	6433	3109	6547	3055	6458	3097	6344	3153
6421	3115	6395	3127	6412	3119	6413	3119	6457	3097
6472	3090	6445	3103	6523	3066	6452	3100	6450	3101
6423	3114	6453	3099	6455	3098	6406	3122	6451	3100
6500	3077	6477	3088	6474	3089	6440	3106	6503	3076
6406	3122	6403	3124	6547	3055	6472	3090	6356	3147
6445	3103	6462	3095	6532	3062	6416	3117	6422	3114
6455	3098	6516	3069	6398	3126	6479	3087	6435	3108
6513	3071	6469	3092	6439	3106	6304	3173	6461	3095
Mean	3103		3100		3087		3111		3106
Ex Var	54		58		71		86		85
Std Dev	18		16		25		24		26

VELOCITY DATA

Date: 21 February 1968

<u>Target 1</u>		<u>Target 2</u>		<u>Target 3</u>		<u>Target 4</u>		<u>Target 5</u>	
<u>Time</u>	<u>Velocity</u>	<u>Time</u>	<u>Velocity</u>	<u>Time</u>	<u>Velocity</u>	<u>Time</u>	<u>Velocity</u>	<u>Time</u>	<u>Velocity</u>
<u>Rifle 859908(8) and Cartridge Lot RA5320</u>						<u>Time: 1000 to 1030</u>			
6308	3171	6247	3202	6208	3222	6288	3181	6276	3187
6225	3213	6211	3220	6221	3215	6186	3233	6340	3155
6233	3209	6280	3185	6255	3197	6275	3187	6245	3203
6212	3220	6190	3231	6262	3194	6320	3165	6362	3144
6325	3162	6303	3173	6240	3205	6235	3208	6206	3223
6250	3200	6364	3143	6277	3186	6222	3214	6293	3178
6335	3157	6258	3196	6248	3201	6245	3203	6379	3135
6916	3228	6277	3186	6280	3185	6339	3155	6269	3190
6190	3231	6184	3234	6306	3172	6266	3192	6282	3184
6313	3168	6292	3179	6260	3195	6226	3212	6283	3183
Mean	3196		3195		3197		3195		3178
Ex Var	74		91		50		78		88
Std Dev	27		27		14		23		25

Rifle 863323(11) and Cartridge Lot TW18191Time: 1043 to 1110

6463	3095	6437	3107	6436	3108	6514	3070	6464	3094
6525	3065	6527	3064	6512	3071	6496	3079	6474	3089
6454	3099	6499	3077	6416	3117	6450	3101	6860	2915
6567	3046	6517	3069	6452	3100	6456	3098	6431	3110
6612	3025	6471	3091	6555	3051	6435	3108	6436	3108
6561	3048	6471	3091	6487	3083	6505	3075	6479	3087
6628	3018	6543	3057	6497	3078	6433	3109	6448	3102
6544	3056	6502	3076	6399	3125	6510	3072	6457	3097
6607	3027	6596	3032	6384	3133	6509	3073	6443	3104
6495	3079	6431	3110	6444	3104	6514	3070	6529	3063
Mean	3056		3077		3097		3085		3077
Ex Var	81		78		82		39		195
Std Dev	27		22		24		16		55

ACCURACY TEST

Date: 24 February 1968	Temperature:	<u>Start</u> 47F	<u>Finish</u> 47F
Time: 0825 to 1050	Barometer:	30.08 in	30.09 in
Range: 100 Yards	Relative Humidity:	47%	54%

<u>Target Number</u>	<u>Center of Impact from Index Point</u>		<u>MR</u>	<u>MVD</u>	<u>MHD</u>	<u>EVD</u>	<u>EHD</u>	<u>ES</u>
	<u>X</u>	<u>Y</u>						
<u>Rifle No. 848305(2)</u>			<u>Rounds Previously Fired in Rifle: 10,250</u>					
			<u>Cartridge Lot: RA5244</u>					
1	+ 1.0	-15.8	2.45	1.33	1.65	7.3	5.3	8.1 ^a
2	- 0.9	-12.3	1.57	1.09	0.89	5.4	4.6	5.8
3	- 0.8	-10.6	1.03	0.66	0.60	3.2	2.2	3.2
4	- 0.4	-10.4	1.57	1.17	0.82	3.9	3.5	4.3
5	+ 0.1	- 9.4	1.38	1.02	0.76	3.7	3.6	4.9
Average	- 0.2	-11.7	1.60	1.05	0.94	4.7	3.8	5.3

<u>Rifle No. 856133(5)</u>			<u>Rounds Previously Fired in Rifle: 10,250</u>					
			<u>Cartridge Lot: TW18179</u>					
1	- 6.4	- 5.4	2.17	1.66	0.84	10.2	3.5	10.3 ^b
2	- 5.2	- 3.3	1.07	0.55	0.78	2.4	2.9	3.2
3	- 5.3	- 2.5	0.90	0.64	0.51	2.4	2.0	2.5
4	- 5.6	- 2.7	1.17	0.92	0.65	3.4	2.6	4.0
5	- 6.1	- 2.5	1.08	0.54	0.85	2.7	4.4	4.8
Average	- 5.7	- 3.3	1.28	0.86	0.73	4.2	3.1	5.0

<u>Rifle No. 859908(8)</u>			<u>Rounds Previously Fired in Rifle: 10,250</u>					
			<u>Cartridge Lot: RA5320</u>					
1	+ 7.6	- 9.1	1.53	1.15	0.82	5.3	2.9	5.6
2	+ 7.3	- 8.1	1.38	1.16	0.60	4.7	2.5	5.2
3	+ 7.5	- 7.1	1.39	0.97	0.77	4.6	2.4	5.0
4	+ 6.1	- 5.4	1.06	0.84	0.57	3.7	2.7	4.4
5	+ 6.5	- 5.6	1.21	0.91	0.68	3.2	2.3	3.9
Average	+ 7.0	- 7.1	1.31	1.01	0.69	4.3	2.6	4.8

<u>Rifle No. 863323(11)</u>			<u>Rounds Previously Fired in Rifle: 10,250</u>					
			<u>Cartridge Lot: TW18191</u>					
1	- 0.8	- 9.2	1.97	1.48	0.94	7.6	4.7	7.8 ^c
2	0.0	- 8.3	1.62	1.19	0.84	4.4	3.4	4.9
3	- 0.5	- 8.0	2.17	1.53	1.37	5.8	3.8	6.8
4	+ 0.1	- 8.3	1.65	1.04	1.18	2.8	5.4	5.4
5	+ 0.1	- 7.7	1.80	0.86	1.42	4.5	5.5	5.6
Average	- 0.2	- 8.3	1.84	1.22	1.15	5.0	4.6	6.1

a 9 Shots in 5.2

b 9 Shots in 3.7

c 9 Shots in 5.3

VELOCITY DATA

Date: 24 February 1968

<u>Target 1</u>		<u>Target 2</u>		<u>Target 3</u>		<u>Target 4</u>		<u>Target 5</u>	
<u>Time</u>	<u>Velocity</u>	<u>Time</u>	<u>Velocity</u>	<u>Time</u>	<u>Velocity</u>	<u>Time</u>	<u>Velocity</u>	<u>Time</u>	<u>Velocity</u>
<u>Rifle 848305(2) and Cartridge Lot RA5244</u>						<u>Time: 0825 to 0850</u>			
6467	3093	6351	3149	6232	3209	6278	3186	6319	3165
6385	3132	6434	3108	6277	3186	6228	3211	6254	3198
6317	3166	6373	3138	6252	3199	6320	3165	6342	3154
6369	3140	6350	3150	6291	3179	6336	3157	6373	3138
6216	3218	6336	3157	6269	3190	6238	3206	6307	3171
6470	3091	6318	3166	6249	3201	6262	3194	6340	3155
6490	3082	6375	3137	6303	3173	6239	3206	6241	3205
6448	3102	6316	3167	6257	3196	6366	3142	6211	3220
6386	3132	6266	3192	6384	3133	6298	3176	6221	3215
6507	3074	6265	3192	6337	3156	6336	3157	6215	3218
Mean	3123		3156		3182		3180		3184
Ev Var	144		84		76		69		82
Std Dev	42		24		22		23		29

Rifle 856133(5) and Cartridge Lot TW18179

Time: 0905 to 0930

6546	3055	6641	3012	6506	3074	6590	3035	6508	3073
6562	3048	6466	3093	6571	3044	6458	3097	6492	3081
6472	3090	6459	3096	6587	3036	6506	3074	6485	3084
6496	3079	6401	3125	6523	3066	6534	3061	6564	3047
6560	3049	6473	3090	6653	3006	6480	3086	6560	3049
6576	3041	6494	3080	6483	3085	6544	3056	6521	3067
6555	3051	6515	3070	6607	3027	6715	2978	6558	3050
6520	3067	6547	3055	6532	3062	6576	3041	6469	3092
6487	3083	6631	3016	6560	3049	6490	3082	6487	3083
6480	3086	6501	3076	6446	3103	6475	3089	6505	3075
Mean	3065		3071		3055		3060		3070
Ex Var	49		113		97		119		45
Std Dev	17		34		27		33		15

VELOCITY DATA

Date: 24 February 1968

<u>Target 1</u>		<u>Target 2</u>		<u>Target 3</u>		<u>Target 4</u>		<u>Target 5</u>	
<u>Time</u>	<u>Velocity</u>	<u>Time</u>	<u>Velocity</u>	<u>Time</u>	<u>Velocity</u>	<u>Time</u>	<u>Velocity</u>	<u>Time</u>	<u>Velocity</u>
<u>Rifle 859908(8) and Cartridge Lot RA5320</u>						<u>Time: 0945 to 1010</u>			
6213	3219	6269	3190	6205	3223	6246	3202	6237	3207
6271	3189	6267	3191	6191	3230	6193	3229	6236	3207
6239	3206	6261	3194	6230	3210	6244	3203	6179	3237
6276	3187	6200	3226	6222	3214	6223	3214	6176	3238
6203	3224	6200	3226	6276	3187	6222	3214	6243	3204
6267	3191	6271	3189	6235	3208	6226	3212	6228	3211
6249	3201	6233	3209	6284	3183	6281	3184	6298	3176
6228	3211	6219	3216	6234	3208	6231	3210	6205	3223
6291	3179	6265	3192	6319	3165	6269	3190	6278	3186
6252	3199	6303	3173	6208	3222	6202	3225	6278	3186
Mean	3201		3201		3205		3208		3207
Ex Var	45		53		65		45		62
Std Dev	14		17		20		13		20

<u>Rifle 863323(11) and Cartridge Lot TW18191</u>						<u>Time: 1025 to 1050</u>			
6539	3059	6516	3069	6465	3094	6523	3066	6445	3103
6590	3035	6502	3076	6423	3114	6533	3061	6586	3037
6569	3045	6504	3075	6545	3056	6461	3095	6558	3050
6595	3033	6636	3014	6542	3057	6442	3105	6454	3099
6543	3057	6480	3086	6622	3020	6563	3047	6410	3120
6398	3126	6371	3139	6541	3058	6472	3090	6501	3076
6612	3025	6508	3073	6546	3055	6519	3068	6476	3088
6528	3064	6540	3058	6541	3058	6543	3057	6458	3097
6512	3071	6487	3083	6468	3092	6488	3083	6515	3070
6539	3059	6513	3071	6559	3049	6473	3090	6479	3087
Mean	3057		3074		3065		3076		3083
Ex Var	101		125		94		58		83
Std Dev	27		29		26		18		24

ACCURACY TEST

Date: 24 February 1968
 Time: 1245 to 1505
 Range: 100 Yards

Temperature: 46F 48F
 Barometer: 30.05 in 29.97 in
 Relative Humidity: 46% 48%

Target Number	Center of Impact from Index Point		MR	MVD	MHD	EVD	EHD	ES
	X	Y						
<u>Rifle No. 850464(3)</u>			<u>Rounds Previously Fired in Rifle: 0</u>					
			<u>Cartridge Lot: RA5244</u>					
1	+ 6.8	-11.7	1.92	1.58	0.75	9.0	4.0	9.0 ^a
2	+ 7.9	-10.5	1.31	1.03	0.60	6.3	3.3	6.7 ^b
3	+ 7.7	- 9.7	0.83	0.56	0.53	2.0	2.3	2.6
4	+ 8.0	- 8.7	1.33	1.24	0.38	4.2	1.4	4.3
5	+ 7.8	- 8.4	0.83	0.51	0.54	2.0	2.6	2.7
Average	+ 7.6	- 9.8	1.24	0.98	0.56	4.7	2.7	5.1

<u>Rifle No. 856760(6)</u>			<u>Rounds Previously Fired in Rifle: 0</u>					
			<u>Cartridge Lot: TW18179</u>					
1	- 0.7	- 5.3	1.23	1.08	0.35	4.4	1.9	4.4
2	+ 0.2	- 4.4	0.86	0.72	0.32	2.2	2.1	2.6
3	+ 0.1	- 3.8	1.00	0.63	0.69	3.2	3.7	4.4
4	- 0.4	- 4.2	1.16	0.76	0.79	3.3	3.6	4.9
5	- 1.7	- 3.1	1.34	1.04	0.79	3.1	3.5	4.4
Average	- 0.5	- 4.2	1.12	0.85	0.59	3.2	3.0	4.1

<u>Rifle No. 861015(9)</u>			<u>Rounds Previously Fired in Rifle: 0</u>					
			<u>Cartridge Lot: RA5320</u>					
1	+ 7.1	- 4.7	1.75	0.86	1.24	5.8	5.2	6.8
2	+ 7.8	- 3.9	1.22	0.83	0.73	4.0	2.6	4.0
3	+ 7.8	- 4.3	1.32	0.74	0.95	3.3	4.1	4.2
4	+ 8.4	- 3.2	1.73	1.36	0.95	4.2	3.9	5.4
5	+ 7.9	- 3.5	1.49	1.12	0.75	5.0	3.8	5.5
Average	+ 7.8	- 3.9	1.50	0.98	0.92	4.5	3.9	5.2

<u>Rifle No. 863632(12)</u>			<u>Rounds Previously Fired in Rifle: 0</u>					
			<u>Cartridge Lot TW18191</u>					
1	+ 0.2	- 3.8	1.52	1.06	0.89	5.8	4.2	6.5 ^c
2	+ 3.1	- 2.0	1.55	0.98	1.03	5.6	4.8	6.7 ^c
3	+ 4.3	- 1.6	0.95	0.63	0.56	2.5	2.7	2.9 ^d
4	+ 3.6	- 0.9	1.20	0.67	0.86	4.2	2.7	4.3 ^d
5	+ 3.9	- 1.4	1.24	0.76	0.86	2.8	3.1	3.6
Average	+ 3.0	- 1.9	1.29	0.82	0.84	4.2	3.5	4.8

a 9 Shots in 5.8 b 9 Shots in 2.5 c 9 Shots in 3.1
 d 9 Shots in 2.8

VELOCITY DATA

Date: 24 February 1968

<u>Target 1</u>		<u>Target 2</u>		<u>Target 3</u>		<u>Target 4</u>		<u>Target 5</u>	
<u>Time</u>	<u>Velocity</u>	<u>Time</u>	<u>Velocity</u>	<u>Time</u>	<u>Velocity</u>	<u>Time</u>	<u>Velocity</u>	<u>Time</u>	<u>Velocity</u>
<u>Rifle 850464(3) and Cartridge Lot RA5244</u>						<u>Time: 1245 to 1315</u>			
6509	3073	6266	3192	6323	3163	6226	3212	6255	3197
6375	3137	6211	3220	6245	3203	6326	3162	6182	3235
6333	3158	6291	3179	6389	3130	6329	3160	6194	3229
6347	3151	6239	3206	6341	3154	6223	3214	6301	3174
6427	3112	6275	3187	6149	3253	6228	3211	6242	3204
6249	3201	6233	3209	6241	3205	6231	3210	6306	3172
6327	3161	6285	3182	6240	3205	6248	3201	6244	3203
6318	3166	6224	3213	6215	3218	6149	3253	6276	3187
6229	3211	6217	3217	6224	3213	6375	3137	6254	3198
6281	3184	6269	3190	6227	3212	6183	3235	6190	3231
Mean	3155		3200		3196		3199		3203
Ex Var	138		41		123		116		63
Std Dev	39		14		34		34		22

Rifle 856760(6) and Cartridge Lot TW18179

Time: 1325 to 1350

6332	3159	6369	3140	6386	3132	6404	3123	6266	3192
6320	3165	6378	3136	6359	3145	6367	3141	6397	3126
6295	3177	6360	3145	6416	3117	6261	3194	6429	3111
6212	3220	6313	3168	6367	3141	6189	3232	6288	3181
6335	3157	6236	3207	6337	3156	6404	3123	6384	3133
6411	3120	6438	3107	6320	3165	6243	3204	6296	3177
6380	3135	6399	3125	6353	3148	6304	3173	6369	3140
6373	3138	6340	3155	6341	3154	6443	3104	6382	3134
6313	3168	6381	3134	6334	3158	6282	3184	6315	3167
6292	3179	6431	3110	6374	3138	6382	3134	6315	3167
Mean	3162		3143		3145		3161		3153
Ex Var	100		100		48		128		81
Std Dev	26		28		13		40		26

VELOCITY DATA

Date: 24 February 1968

<u>Target 1</u>		<u>Target 2</u>		<u>Target 3</u>		<u>Target 4</u>		<u>Target 5</u>	
<u>Time</u>	<u>Velocity</u>	<u>Time</u>	<u>Velocity</u>	<u>Time</u>	<u>Velocity</u>	<u>Time</u>	<u>Velocity</u>	<u>Time</u>	<u>Velocity</u>
<u>Rifle 861015(9) and Cartridge Lot RA5320</u>									
6306	3172	6164	3245	6168	3243	6196	3228	6138	3258
6248	3201	6246	3202	6221	3215	6235	3208	6231	3210
6305	3172	6308	3171	6207	3222	6180	3236	6227	3212
6252	3199	6207	3222	6223	3214	6196	3228	6157	3248
6299	3175	6237	3207	6284	3183	6136	3259	6240	3205
6238	3206	6193	3229	6257	3196	6220	3215	6233	3209
6292	3179	6211	3220	6254	3198	6185	3234	6257	3196
6255	3197	6224	3213	6218	3216	6205	3223	6230	3210
6169	3242	6238	3206	6185	3234	6183	3235	6166	3244
6199	3226	6204	3224	6282	3184	6229	3211	6129	3263
Mean	3197		3214		3210		3228		3226
Ex Var	70		74		59		51		67
Std Dev	23		19		19		14		24

Rifle 863632(12) and Cartridge Lot TW18191 Time: 1438 to 1505

6381	3134	6397	3126	6333	3158	6338	3156	6380	3135
6355	3147	6368	3141	6371	3139	6332	3159	6307	3171
6279	3185	6335	3157	6331	3159	6313	3168	6356	3147
6379	3135	6333	3158	6379	3135	6291	3179	6336	3157
6454	3099	6338	3156	6412	3119	6345	3152	6287	3181
6414	3118	6404	3123	6280	3185	6311	3169	6384	3133
6344	3153	6319	3165	6296	3177	6355	3147	6373	3138
6362	3144	6372	3139	6308	3171	6331	3159	6297	3176
6315	3167	6291	3179	6274	3188	6324	3163	6335	3157
6321	3164	6367	3141	6373	3138	6338	3156	6300	3175
Mean	3145		3149		3157		3161		3157
Ex Var	86		56		69		32		48
Std Dev	24		17		22		9		17

ACCURACY TEST

Date: 27 February 1968	Temperature: <u>Start</u> 47F	<u>Finish</u> 49F
Time: 0830 to 1100	Barometer: 30.04 in	30.04 in
Range: 100 Yards	Relative Humidity: 54%	44%

Target Number	Center of Impact from Index Point		MR	MVD	MHD	EVD	EHD	ES
	X	Y						
<u>Rifle 850464(3)</u>			<u>Rounds Previously Fired in Rifle: 2050</u>					
<u>Cartridge Lot: RA 5244</u>								
1	+ 7.0	-11.2	1.60	1.13	0.95	5.9	4.3	6.4 ^a
2	+ 9.2	- 8.3	1.45	1.05	0.76	6.0	2.6	6.1 ^b
3	+11.3	- 7.6	1.07	0.77	0.60	2.9	2.0	3.0
4	+11.7	- 6.1	1.75	1.51	0.65	5.7	3.8	6.2
5	+10.9	- 4.7	1.24	0.91	0.61	4.1	4.2	4.7
Average	+10.0	- 7.6	1.42	1.07	0.71	4.9	3.4	5.3

<u>Rifle 856760(6)</u>			<u>Rounds Previously Fired in Rifle: 2050</u>					
<u>Cartridge Lot: TW18179</u>								
1	- 1.0	- 9.0	1.44	1.11	0.62	5.3	3.1	5.3 ^c
2	- 0.1	- 7.7	0.72	0.56	0.40	2.0	1.6	2.2
3	- 0.7	- 7.3	1.19	0.87	0.69	3.7	3.1	4.0
4	- 0.1	- 7.7	1.05	0.82	0.49	3.1	1.8	3.1
5	- 0.4	- 6.5	1.01	0.70	0.66	3.3	2.9	4.0
Average	- 0.5	- 7.6	1.08	0.81	0.57	3.5	2.5	3.7

<u>Rifle 861015(9)</u>			<u>Rounds Previously Fired in Rifle: 2050</u>					
<u>Cartridge Lot: RA5320</u>								
1	+ 7.6	- 5.6	1.34	0.79	0.71	4.9	3.6	4.9 ^d
2	+ 7.4	- 5.9	1.04	0.89	0.49	3.4	2.9	4.3
3	+ 6.9	- 6.4	1.11	0.74	0.69	3.1	2.8	3.2
4	+ 6.7	- 3.3	1.51	1.08	0.76	4.3	3.5	4.4
5	+ 5.7	- 2.2	1.36	1.09	0.63	4.2	3.5	4.7
Average	+ 6.9	- 4.7	1.27	0.92	0.66	4.0	3.3	4.3

<u>Rifle 863632(12)</u>			<u>Rounds Previously Fired in Rifle: 2070</u>					
<u>Cartridge Lot: TW18191</u>								
1	+ 0.8	-11.6	1.78	1.45	0.58	8.5	3.9	8.5 ^e
2	+ 1.1	-10.0	1.79	0.95	1.36	3.6	6.0	6.6 ^f
3	+ 0.9	- 9.6	0.96	0.71	0.49	2.9	1.8	3.1
4	+ 1.3	- 9.8	0.91	0.63	0.54	2.4	2.2	2.6
5	+ 0.4	- 8.3	1.87	1.39	1.24	4.4	4.3	6.0
Average	+ 0.9	- 9.9	1.46	1.03	0.84	4.4	3.6	5.4

a 9 Shots in 4.2 b 9 Shots in 3.8 c 9 Shots in 3.2
d 9 Shots in 3.6 e 9 Shots in 5.1 f 9 Shots in 4.0

VELOCITY DATA

Date: 27 February 1968

<u>Target 1</u>		<u>Target 2</u>		<u>Target 3</u>		<u>Target 4</u>		<u>Target 5</u>	
<u>Time</u>	<u>Velocity</u>	<u>Time</u>	<u>Velocity</u>	<u>Time</u>	<u>Velocity</u>	<u>Time</u>	<u>Velocity</u>	<u>Time</u>	<u>Velocity</u>
<u>Rifle 850464(3) and Cartridge Lot RA5244</u>						<u>Time: 0830 to 0857</u>			
6397	3126	6278	3186	6248	3201	6265	3192	6211	3220
6383	3133	6376	3137	6296	3177	6312	3169	6264	3193
6366	3142	6220	3215	6238	3206	6271	3189	6256	3197
6276	3187	6392	3129	6236	3207	6234	3208	6258	3196
6262	3194	6224	3213	6280	3185	6212	3220	6310	3170
6252	3199	6191	3230	6345	3152	6328	3161	6325	3162
6419	3116	6398	3126	6249	3201	6291	3179	6279	3185
6363	3143	6304	3173	6238	3206	6358	3146	6256	3197
6313	3168	6336	3157	6270	3190	6270	3190	6267	3191
6332	3159	6227	3212	6360	3145	6324	3163	6266	3192
Mean	3157		3178		3187		3182		3190
Ex Var	83		104		62		74		58
Std Dev	28		37		22		22		15

Rifle 856760(6) and Cartridge Lot TW18179

Time: 0910 to 1040

6348	3151	6364	3143	6362	3144	6317	3166	6316	3167
6497	3078	6465	3094	6329	3160	6308	3171	6356	3147
6391	3129	6437	3107	6333	3158	6388	3131	6293	3178
6459	3096	6446	3103	6264	3193	6322	3164	6416	3117
6552	3053	6378	3136	6323	3163	6300	3175	6389	3130
6390	3130	6535	3060	6385	3132	6290	3180	6325	3162
6407	3122	6473	3090	6296	3177	6297	3176	6358	3146
6534	3061	6407	3122	6401	3125	6376	3137	6413	3119
6471	3091	6383	3133	6412	3119	6316	3167	6353	3148
6502	3076	6500	3077	6493	3080	6393	3128	6485	3084
Mean	3099		3106		3145		3159		3140
Ex Var	98		83		113		52		94
Std Dev	31		26		31		19		26

VELOCITY DATA

Date: 27 February 1968

<u>Target 1</u>		<u>Target 2</u>		<u>Target 3</u>		<u>Target 4</u>		<u>Target 5</u>	
<u>Time</u>	<u>Velocity</u>	<u>Time</u>	<u>Velocity</u>	<u>Time</u>	<u>Velocity</u>	<u>Time</u>	<u>Velocity</u>	<u>Time</u>	<u>Velocity</u>
<u>Rifle 861015(9) and Cartridge Lot RA5320</u>						<u>Time: 0955 to 1020</u>			
6111	3273	6229	3211	6190	3231	6169	3242	6192	3230
6137	3259	6189	3232	6234	3208	6244	3203	6345	3203
6227	3212	6225	3213	6218	3216	6247	3202	6177	3238
6215	3218	6200	3226	6278	3186	6274	3188	6307	3171
6155	3249	6229	3211	6216	3218	6208	3222	6171	3241
6284	3183	6206	3223	6155	3249	6212	3220	6206	3223
6264	3193	6168	3243	6186	3233	6200	3226	6210	3221
6155	3249	6181	3236	6222	3214	6259	3195	6216	3218
6273	3188	6215	3218	6181	3236	6251	3199	6235	3208
6161	3246	6211	3220	6204	3224	6200	3226	6209	3221
Mean	3227		3223		3222		3212		3217
Ex Var	90		32		63		54		70
Std Dev	31		10		17		16		19

Rifle 863632(12) and Cartridge Lot TW18191

Time: 1030 to 1100

6400	3125	6346	3152	6359	3145	6396	3127	6388	3131
6355	3147	6369	3140	6389	3130	6365	3142	6329	3160
6360	3145	6339	3155	6416	3117	6361	3144	6412	3119
6406	3123	6356	3147	6336	3157	6397	3126	6384	3133
6424	3113	6360	3145	6353	3148	6398	3126	6450	3101
6426	3112	6382	3134	6380	3135	6368	3141	6388	3131
6469	3092	6380	3135	6407	3122	6444	3104	6362	3144
6412	3119	6337	3156	6381	3134	6350	3150	6349	3150
6356	3147	6406	3122	6398	3126	6346	3152	6361	3144
6484	3085	6311	3169	6418	3116	6344	3153	6371	3139
Mean	3121		3145		3133		3136		3135
Ex Var	62		47		41		49		59
Std Dev	21		13		13		15		16

ACCURACY TEST

Date: 29 February 1968
 Time: 0830 to 1055
 Range: 100 Yards

Temperature: 48F
 Barometer: 29.87 in
 Relative Humidity: 66%
 Start 48F
 Finish 48F
 29.71 in
 72%

Target Number	Center of Impact from Index Point		MR	MVD	MHD	EVD	EHD	ES
	X	Y						
Rifle 850464(3)			Rounds Previously Fired in Rifle: 4100					4100
Cartridge Lot: RA5244								

1	+ 7.2	- 8.9	2.05	1.74	0.83	8.7	3.3	9.1 ^a
2	+ 7.2	- 7.8	0.92	0.75	0.38	4.0	1.7	4.1
3	+ 7.1	- 9.0	1.11	0.73	0.63	3.4	2.8	3.4
4	+ 9.5	-10.1	1.79	0.70	1.53	3.5	7.1	7.8
5	+13.6	- 7.6	2.50	1.79	1.52	6.4	6.2	8.7
Average	+ 8.9	- 8.7	1.67	1.14	0.98	5.2	4.2	6.6

Rifle 856760(6)						Rounds Previously Fired in Rifle: 4100		
Cartridge Lot: TW18179								

1	- 4.0	- 4.5	1.38	1.29	0.26	7.5	1.1	7.5 ^b
2	- 4.0	- 3.1	0.87	0.62	0.49	2.9	1.6	2.9
3	- 4.3	- 2.9	0.67	0.49	0.33	2.2	1.4	2.2
4	- 3.6	- 2.3	1.11	0.84	0.61	2.9	2.4	3.0
5	- 3.8	- 2.0	1.02	0.59	0.68	2.6	3.7	3.8
Average	- 3.9	- 3.0	1.01	0.77	0.47	3.6	2.0	3.9

Rifle 861015(9)						Rounds Previously Fired in Rifle: 4100		
Cartridge Lot: RA5320								

1	+ 1.4	- 7.3	1.94	1.64	0.77	7.1	3.4	7.4 ^c
2	+ 0.4	- 8.2	1.40	0.94	0.85	3.7	3.5	4.6
3	+ 0.8	- 9.3	1.65	0.96	1.23	3.7	4.1	4.7
4	+ 3.0	- 9.8	1.42	0.80	0.91	4.3	5.0	5.2
5	+ 4.3	- 8.3	1.19	0.80	0.74	3.4	3.0	3.8
Average	+ 2.0	- 8.6	1.52	1.03	0.90	4.4	3.8	5.1

Rifle 863632(12)						Rounds Previously Fired in Rifle: 4120		
Cartridge Lot: TW18191								

1	- 0.4	- 5.1	1.80	1.31	1.00	6.2	3.9	6.2 ^d
2	+ 0.3	- 3.3	1.13	0.74	0.70	4.2	3.1	4.3
3	+ 0.2	- 2.8	0.98	0.71	0.58	2.1	2.4	2.7
4	+ 1.3	- 2.4	1.15	0.54	0.93	1.6	3.9	3.9
5	+ 0.6	- 1.5	1.09	0.88	0.55	3.0	2.0	3.5
Average	+ 0.4	- 3.0	1.23	0.84	0.75	3.4	3.1	4.1

a 9 Shots in 4.1 b 9 Shots in 3.2 c 9 Shots in 5.4
 d 9 Shots in 4.1

VELOCITY DATA

Date: 29 February 1968

<u>Target 1</u>		<u>Target 2</u>		<u>Target 3</u>		<u>Target 4</u>		<u>Target 5</u>	
<u>Time</u>	<u>Velocity</u>	<u>Time</u>	<u>Velocity</u>	<u>Time</u>	<u>Velocity</u>	<u>Time</u>	<u>Velocity</u>	<u>Time</u>	<u>Velocity</u>
<u>Rifle 861015(9) and Cartridge Lot RA5320</u>						<u>Time: 0950 to 1015</u>			
6238	3206	6209	3221	6229	3211	6228	3211	6225	3213
6242	3204	6218	3216	6255	3197	6190	3231	6226	3212
6222	3214	6265	3192	6241	3205	6268	3191	6281	3184
6236	3207	6239	3206	6198	3227	6234	3208	6227	3212
6271	3189	6283	3183	6216	3218	6194	3229	6203	3224
6265	3192	6238	3206	6225	3213	6294	3178	6196	3228
6245	3203	6214	3219	6222	3214	6240	3205	6296	3177
6226	3212	6307	3171	6199	3226	6171	3241	6207	3222
6224	3213	6257	3196	6232	3209	6205	3223	6234	3208
6236	3207	6247	3202	6220	3215	6264	3193	6193	3229
Mean	3205		3201		3214		3211		3211
Ex Var	25		50		30		63		52
Std Dev	8		15		9		19		17

Rifle 863632(12) and Cartridge Lot TW18191

Time: 1030 to 1055

6415	3118	6437	3107	6362	3144	6560	3049	6348	3151
6497	3078	6436	3108	6380	3135	6451	3100	6342	3154
6381	3134	6361	3144	6366	3142	6444	3104	6401	3125
6481	3086	6373	3138	6464	3094	6426	3112	6419	3116
6447	3102	6362	3144	6358	3146	6499	3077	6377	3136
6462	3095	6520	3067	6455	3098	6340	3155	6285	3182
6424	3113	6325	3162	6431	3110	6497	3078	6451	3100
6497	3078	6435	3108	6411	3120	6333	3158	6450	3101
6429	3111	6435	3108	6362	3144	6357	3146	6507	3074
6457	3097	6415	3118	6463	3095	6536	3060	6399	3125
Mean	3101		3120		3123		3104		3126
Ex Var	56		95		52		109		108
Std Dev	17		26		21		37		30

ACCURACY TEST

Date: 2 March 1968	Temperature: <u>49F</u>	<u>Start</u>	<u>Finish</u>
Time: 0830 to 1100	Barometer: 29.56 in	49F	49F
Range: 100 Yards	Relative Humidity: 49%	29.56 in	29.56 in

Center of Impact
from Index Point

Target Number	X	Y	MR	MVD	MHD	EVD	EHD	ES
<u>Rifle No. 850464(3)</u>			<u>Rounds Previously Fired in Rifle: 6150</u>					<u>6150</u>
<u>Cartridge Lot: RA5244</u>								
1	+ 8.2	- 7.5	0.97	0.80	0.36	4.8	1.6	4.9 ^a
2	+ 9.1	- 4.4	2.45	1.22	1.93	4.8	5.9	6.0
3	+10.0	- 4.9	1.61	0.69	1.41	2.6	3.7	4.0
4	+10.6	- 4.7	1.43	1.04	0.76	4.8	2.9	5.1
5	+10.8	- 4.3	1.48	1.16	0.79	4.1	2.9	4.8
Average	+ 9.7	- 5.2	1.59	0.98	1.05	4.2	3.4	5.0

<u>Rifle No. 856760(6)</u>			<u>Rounds Previously Fired in Rifle: 6150</u>					
<u>Cartridge Lot: TW18179</u>								
1	- 3.2	- 0.3	1.15	0.79	0.65	4.0	2.1	4.4
2	- 2.5	+ 0.8	0.78	0.36	0.59	2.0	2.5	2.5
3	- 1.8	+ 1.1	0.69	0.44	0.45	2.0	1.8	2.5
4	- 1.4	+ 1.6	0.90	0.49	0.65	2.1	2.0	2.6
5	- 1.2	+ 1.6	0.94	0.60	0.64	2.2	2.3	2.5
Average	- 2.0	+ 1.0	0.89	0.54	0.60	2.5	2.1	2.9

<u>Rifle No. 861015(9)</u>			<u>Rounds Previously Fired in Rifle: 6150</u>					
<u>Cartridge Lot: RA5320</u>								
1	+ 6.9	+ 0.5	1.52	1.21	0.74	6.9	3.5	7.2 ^b
2	+ 5.7	+ 1.3	1.53	1.17	0.85	6.1	4.2	6.8 ^c
3	+ 5.1	+ 2.3	1.19	0.81	0.76	3.9	2.8	4.6
4	+ 4.9	+ 2.4	1.35	1.04	0.74	4.1	3.1	4.6
5	+ 3.9	+ 2.0	0.99	0.63	0.59	2.8	3.1	3.3
Average	+ 5.3	+ 1.7	1.32	0.97	0.74	4.8	3.3	5.3

<u>Rifle No. 863632(12)</u>			<u>Rounds Previously Fired in Rifle: 6170</u>					
<u>Cartridge Lot: TW18191</u>								
1	+ 0.7	- 4.4	1.88	1.34	1.06	7.6	5.1	7.7 ^d
2	+ 0.1	- 2.3	1.25	0.94	0.68	4.2	2.6	4.9
3	+ 0.3	- 2.0	1.68	1.10	1.18	3.9	4.0	5.5
4	+ 0.6	- 1.7	1.75	1.25	1.06	4.6	4.3	5.5
5	+ 0.6	- 2.3	1.02	0.72	0.55	3.0	2.8	3.6
Average	+ 0.5	- 2.5	1.52	1.07	0.91	4.7	3.8	5.4

a 9 Shots in 2.0
d 9 Shots in 4.3

b 9 Shots in 5.2

c 9 Shots in 3.9

VELOCITY DATA

Date: 2 March 1968

<u>Target 1</u>		<u>Target 2</u>		<u>Target 3</u>		<u>Target 4</u>		<u>Target 5</u>	
<u>Time</u>	<u>Velocity</u>	<u>Time</u>	<u>Velocity</u>	<u>Time</u>	<u>Velocity</u>	<u>Time</u>	<u>Velocity</u>	<u>Time</u>	<u>Velocity</u>
Rifle 850464(3) and Cartridge Lot RA5244						Time: 0830 to 0855			
6339	3155	6265	3192	6382	3134	6291	3179	6232	3209
6334	3158	6284	3183	6279	3185	6207	3222	6181	3236
6344	3153	6344	3153	6220	3215	6268	3191	6267	3191
6334	3158	6267	3191	6294	3178	6236	3207	6184	3234
6389	3130	6270	3190	6244	3203	6259	3195	6277	3186
6358	3146	6300	3175	6253	3198	6237	3207	6200	3226
6386	3132	6248	3201	6198	3227	6227	3212	6137	3259
6313	3168	6350	3150	6257	3196	6285	3182	6258	3196
6294	3178	6291	3179	6277	3186	6228	3211	6250	3200
6352	3149	6249	3201	6296	3177	6168	3243	6173	3240
Mean	3152		3181		3190		3205		3218
Ex Var	48		51		93		64		73
Std Dev	14		17		24		18		23

Rifle 856760(6) and Cartridge Lot TW18179

Time: 0906 to 0935

6365	3142	6394	3128	6354	3148	6351	3149	6427	3112
6413	3119	6463	3095	6369	3140	6387	3131	6330	3160
6398	3126	6409	3121	6473	3090	6438	3107	6404	3123
6412	3119	6395	3127	6416	3117	6447	3102	6429	3111
6510	3072	6393	3128	6369	3140	6399	3125	6294	3178
6340	3155	6413	3119	6421	3115	6426	3112	6361	3144
6465	3094	6398	3126	6359	3145	6386	3132	6404	3123
6426	3112	6372	3139	6537	3060	6404	3123	6426	3112
6421	3115	6486	3084	6337	3156	6430	3110	6426	3112
6483	3085	6439	3106	6401	3125	6396	3127	6359	3145
Mean	3114		3117		3124		3122		3132
Ex Var	70		55		96		47		67
Std Dev	24		16		28		13		22