

★  
**DRAFT COPY**

TM 9-1005-249-14  
T.O. 11W3-5-5-1  
NAVWEP O.P. 3333  
MC I.D. 05538A

**TECHNICAL MANUAL**

**OPERATION, MAINTENANCE, REPAIR  
AND  
REPLACEMENT PARTS**

**RIFLE, 5.56-MM, M16;  
RIFLE, 5.56-MM, XM16E1;  
AND  
LAUNCHER, GRENADE,  
40-MM, XM148**

**CHANGE**  
NOTICE

**LATEST CHANGE PAGES SUPERSEDED  
THE SAME PAGES OF PREVIOUS DATE**

Insert changed pages into basic  
publication. Destroy superseded pages.

THIS PUBLICATION REPLACES T.O. 11W3-5-5-1 DATED 31 AUGUST 1963

PUBLISHED UNDER THE AUTHORITY OF THE SECRETARIES OF THE  
ARMY, NAVY AND AIR FORCE

★  
**15 JUNE 1964**

CHANGE 6, 1 MAY 1966

Digitized by:

★  
**DRAFT COPY**

TM 9-1005-249-14  
T.O. 11W3-5-5-1  
NAVWEP O.P. 3333  
MC I.D. 05538A

**TECHNICAL MANUAL**

**OPERATION, MAINTENANCE, REPAIR  
AND  
REPLACEMENT PARTS**

**RIFLE, 5.56-MM, M16;  
RIFLE, 5.56-MM, XM16E1;  
AND  
LAUNCHER, GRENADE,  
40-MM, XM148**

**CHANGE**  
NOTICE

**LATEST CHANGE PAGES SUPERSEDED  
THE SAME PAGES OF PREVIOUS DATE**

Insert changed pages into basic  
publication. Destroy superseded pages.

THIS PUBLICATION REPLACES T.O. 11W3-5-5-1 DATED 31 AUGUST 1963

PUBLISHED UNDER THE AUTHORITY OF THE SECRETARIES OF THE  
ARMY, NAVY AND AIR FORCE

★  
**15 JUNE 1964**

CHANGE 6, 1 MAY 1966

Reproduction for military use of the information or illustrations contained in this publication is not permitted without prior written approval of the Headquarters, United States Army Weapons Command

INSERT LATEST CHANGED PAGES. DESTROY SUPERSEDED PAGES.

## LIST OF EFFECTIVE PAGES

Note: The portion of the text affected by the changes is indicated by a vertical line in the outer margins of the page.

Total number of pages in this manual is 120 consisting of the following:

Note: Green pages indicate Operator and Organizational Maintenance information only.  
Blue pages indicate Operator, Organizational, Direct, and General Support Maintenance.  
White pages indicate Direct and General Support Maintenance only.

Page No.	Issue
* Title/and A	1 May 66
* i thru v	1 May 66
vi	15 Nov 64
* 1-1 thru 1-7	1 May 66
* 1-8 Blank	1 May 66
* 2-1	1 May 66
2-2 Blank	Original
* 3-1 thru 3-12	1 May 66
* 4-1	1 May 66
4-2 Blank	Original
* 5-1 thru 5-7	1 May 66
5-8 Blank	Original
* 6-1 thru 6-4	1 May 66
7-1	Original
* 7-2	1 May 66
* 8-1 thru 8-16	1 May 66
8-17	Original
8-18 Blank	Original
* 9-1 thru 9-24	1 May 66
* 10-1 thru 10-3	1 May 66
* 10-4 Blank	1 May 66
11-1 thru 11-2	1 May 65
* 12-1 thru 12-26	1 May 66
Authentication	1 May 66

\* The asterisk indicates pages changed, added, or deleted by the current change.

## TABLE OF CONTENTS

	Page
CHAPTER	
I INTRODUCTION . . . . .	1-1
SECTION	
1. PURPOSE AND SCOPE . . . . .	1-1
1-1. General . . . . .	1-1
1-3. Suggestions and Recommendations . . . . .	1-1
2. DESCRIPTION . . . . .	1-1
1-7. Description . . . . .	1-1
3. TABULATED DATA, RIFLES, M16 AND XM16E1 . . . . .	1-2
1-15. Tabulated Data . . . . .	1-2
4. ACCESSORIES, SPECIAL TOOLS, AND EQUIPMENT . . . . .	1-4
1-17. Accessories . . . . .	1-4
1-19. Special Tools and Equipment . . . . .	1-4
II PREPARATION FOR USE, STORAGE, AND SHIPMENT . . . . .	2-1
SECTION	
1. PREPARATION FOR USE . . . . .	2-1
2-1. General . . . . .	2-1
2. PREPARATION FOR STORAGE AND SHIPMENT . . . . .	2-1
2-5. Storage . . . . .	2-1
2-11. Shipment . . . . .	2-1
III OPERATION INSTRUCTIONS, RIFLES, M16 AND XM16E1 . . . . .	3-1
3-1. Safety Procedure . . . . .	3-1
3-3. Controls . . . . .	3-1
3-5. Cleaning and Lubrication Before Firing . . . . .	3-3
3-9. Loading . . . . .	3-3
3-12. Firing . . . . .	3-3
3-16. Stoppage and Immediate Action . . . . .	3-4
3-19. Unloading . . . . .	3-4
3-21. Installing Accessories . . . . .	3-4
3-23. Disassembly/Assembly . . . . .	3-4
3-25. Cleaning and Lubrication After Firing . . . . .	3-10
3-26. Cleaning and Lubricating the Barrel . . . . .	3-10
3-26.1. Cleaning the Chamber . . . . .	3-10
3-27. Cleaning and Lubricating the Bolt Carrier Group . . . . .	3-10
3-27A. Cleaning and Lubricating the Upper Receiver . . . . .	3-11
3-28. Cleaning and Lubricating the Lower Receiver Group . . . . .	3-12
3-28A. Cleaning of Scabbard M8A1 and Sling . . . . .	3-12
3-28B. Cleaning and Maintenance of Bayonet-Knife, M7 . . . . .	3-12
3-29. Function Check . . . . .	3-12
IV PREVENTIVE MAINTENANCE . . . . .	4-1
4-1. General . . . . .	4-1
4-3. Responsibility . . . . .	4-1
4-5. Specific Procedures . . . . .	4-1
V AMMUNITION . . . . .	5-1
SECTION	
1. RIFLES . . . . .	5-1
5-1. General . . . . .	5-1
5-3. Classification . . . . .	5-1
5-5. Identification . . . . .	5-1
5-12. Care, Handling, and Preservation . . . . .	5-2

TABLE OF CONTENTS (Continued)

5-13. Authorized Rounds . . . . .	5-2
5-15. Preparation for Firing . . . . .	5-3
5-17. Precaution in Firing . . . . .	5-3
5-19. Packing and Marking . . . . .	5-4
2. GRENADE LAUNCHER . . . . .	5-4
5-22. General . . . . .	5-4
5-25. Care, Handling, and Preservation . . . . .	5-5
5-29. Packing . . . . .	5-6
VI DESTRUCTION OF MATERIAL TO PREVENT ENEMY USE . . . . .	6-1
SECTION	
1. RIFLES . . . . .	6-1
6-1. General . . . . .	6-1
6-6. Destruction of the 5.56-MM Rifles M16 and XM16E1 . . . . .	6-1
6-7. Method No. 1 - By Mechanical Means . . . . .	6-1
6-9. Method No. 2 - By Burning . . . . .	6-2
6-10. Method No. 3 - By Disposal . . . . .	6-2
2. GRENADE LAUNCHER . . . . .	6-2
6-12. General . . . . .	6-2
6-13. Method No. 1 - Destruction by Mechanical Means . . . . .	6-3
6-14. Method No. 2 - Destruction by Burning . . . . .	6-3
6-17. Method No. 3 - Destruction by Gunfire . . . . .	6-3
6-18. Method No. 4 - Destruction by Explosives . . . . .	6-3
6-21. Method No. 5 - Destruction by Disposal . . . . .	6-4
VII INSPECTIONS . . . . .	7-1
SECTION	
1. GENERAL . . . . .	7-1
7-1. Scope . . . . .	7-1
7-3. Purpose of Inspection . . . . .	7-1
7-5. Categories of Inspection . . . . .	7-1
7-7. Inspection of Materiel in the Hands of Troops in the Field . . . . .	7-1
7-8. Shop Inspection . . . . .	7-1
7-9. Preembarkation Inspection . . . . .	7-1
2. INSPECTION PROCEDURES . . . . .	7-2
7-11. General . . . . .	7-2
7-13. Inspection Prior to Disassembly . . . . .	7-2
VIII REPAIR OPERATIONS . . . . .	8-1
SECTION	
1. TROUBLE SHOOTING . . . . .	8-1
8-1. General . . . . .	8-1
8-4. Trouble Shooting Procedures . . . . .	8-1
2. DISASSEMBLY AND ASSEMBLY . . . . .	8-2
8-8. General . . . . .	8-2
3. CLEANING AND LUBRICATION . . . . .	8-15
8-10. General . . . . .	8-15
4. INSPECTION, TEST, AND ADJUSTMENT . . . . .	8-16
8-13. Inspection . . . . .	8-16
8-15. Replacement of Parts . . . . .	8-17
8-17. Test . . . . .	8-17
IX BASIC ISSUE ITEMS, TOOLS, AND REPLACEMENT PARTS . . . . .	9-1
9-1. General . . . . .	9-1
9-3. Explanation of Columns . . . . .	9-1
9-5. Figure and Index . . . . .	9-1
9-6. Source and Maintenance Codes . . . . .	9-1
9-11. 15-Day Maintenance Allowance Per 100 Equipments . . . . .	9-2
9-12. Support Units . . . . .	9-3

TABLE OF CONTENTS (Continued)

X	MAINTENANCE ALLOCATION CHART . . . . .	10-1
	10-3. Explanation of Format . . . . .	10-1
XI	BAYONET-KNIFE, M7 AND BAYONET-KNIFE SCABBARD, M8A1	
	11-1. General . . . . .	11-1
	11-3. Bayonet . . . . .	11-1
	11-4. Installation . . . . .	11-1
	11-6. Trouble Shooting . . . . .	11-1
	11-8. Disassemble/Assemble . . . . .	11-1
	11-11. Cleaning . . . . .	11-2
	11-13. Inspect and Repair . . . . .	11-2
	11-14. Bayonet-Knife Scabbard, M8A1 . . . . .	11-2
XII	LAUNCHER, GRENADE, 40-MM XM148	
	12-1. General . . . . .	12-1
	12-3. Tabulated Data . . . . .	12-2
	12-5. Special Tools, Equipment and Repair Parts . . . . .	12-2
	12-6. Preparation for Use, Storage, and Shipment . . . . .	12-2
	12-8. Installation and Removal . . . . .	12-2
	12-10. Operating Instructions . . . . .	12-7
	12-11. Cleaning before Firing . . . . .	12-7
	12-13. Service before Firing . . . . .	12-7
	12-15. Loading . . . . .	12-7
	12-17. Firing . . . . .	12-7
	12-18. Misfire and Hangfire . . . . .	12-7
	12-22. Unloading . . . . .	12-9
	12-24. Cleaning and Lubrication after Firing . . . . .	12-9
	12-25. Preventive Maintenance . . . . .	12-10
	12-27. Ammunition . . . . .	12-11
	12-29. Destruction of Material to Prevent Enemy Use . . . . .	12-11
	12-31. Trouble Shooting . . . . .	12-11
	12-33. Disassembly and Assembly . . . . .	12-11
	12-34. Cleaning and Lubrication . . . . .	12-25
	12-36. Inspection and Repair . . . . .	12-25

LIST OF TABLES

Number	Title	Page
1-1.	Accessories . . . . .	1-4
1-2.	Special Tools and Equipment . . . . .	1-5
4-1.	Preventive Maintenance Checks and Services . . . . .	4-1
5-1.	Authorized Rounds . . . . .	5-3
5-2.	Packing Data for 5.56-MM Ammunition . . . . .	5-4
5-3.	Authorized Rounds . . . . .	5-6
5-4.	Packing Data for 40-MM Ammunition . . . . .	5-7
8-1.	Trouble Shooting . . . . .	8-1
8-2.	Cleaning . . . . .	8-15
8-3.	Inspection . . . . .	8-16
12-1.	Special Tools and Equipment . . . . .	12-3
12-2.	Preventive Maintenance Checks and Services . . . . .	12-11
12-3.	Trouble Shooting . . . . .	12-12
12-4.	Inspection and Repair . . . . .	12-25

## LIST OF ILLUSTRATIONS

Number	Title	Page
1-1.	Rifle, 5.56-MM, M16 and XM16E1 . . . . .	vi
1-2.	Bayonet-Knife M7 and Bayonet-Knife Scabbard M8A1 . . . . .	1-6
1-3.	Bipod Assembly, XM3 . . . . .	1-6
1-4.	Bipod Carrying Case - 62309 . . . . .	1-6
1-5.	Lubricant Case - 7790995 . . . . .	1-6
1-6.	Small Arms Cleaning Rod - 11686326 . . . . .	1-6
1-7.	Small Arms Cleaning Brush - 11686340 . . . . .	1-6
1-8.	Combination Wrench - 11010033 . . . . .	1-7
1-9.	Barrel Remover Fixture - 11010032 . . . . .	1-7
1-10.	Firing Pin Protrusion Gage - 7799735 . . . . .	1-7
1-11.	Headspace Gage (Field Type) - 7799734 . . . . .	1-7
1-12.	Small Arms Cleaning Brush (Chamber) - 8432358 . . . . .	1-7
1-13.	Barrel Erosion Gage - 7799792 . . . . .	1-7
3-1.	Clearing Rifle . . . . .	3-1
3-2.	Controls . . . . .	3-2
3-3.	Installing Accessories . . . . .	3-4
3-4.	Rifles, 5.56-MM, M16 and XM16E1 - Major Groups . . . . .	3-5
3-5.	Disassembly/Assembly of Rifle . . . . .	3-5
3-5A.	Disassembly/Assembly of Bolt Assembly . . . . .	3-9
3-5B.	Disassembly/Assembly of Lower Receiver Group . . . . .	3-9
3-6.	Cleaning Bore with Cleaning Rod - 11686326 and Brush - 11686340 . . . . .	3-10
3-6A.	Cleaning the Chamber . . . . .	3-10
3-7.	Oiling Bolt Rings . . . . .	3-11
3-7A.	Cleaning Carrier Key . . . . .	3-11
3-7B.	Cleaning Gas Tube in Receiver . . . . .	3-11
5-1.	Cartridge, 5.56-MM, Ball, M193 . . . . .	5-1
5-2.	Cartridges used with Grenade Launcher XM148 . . . . .	5-4
5-3.	Items used for Packing and Carrying 40-MM Ammunition . . . . .	5-7
8-1.	Disassembly/Assembly of Bolt Assembly and Carrier and Key . . . . .	8-3
8-2.	Disassembly/Assembly Lower Receiver Group . . . . .	8-4
8-3.	Disassembly/Assembly Upper Receiver Group . . . . .	8-9
8-4.	Disassembly/Assembly of Magazine . . . . .	8-14
8-5.	Checking Barrel Erosion . . . . .	8-16
8-6.	Checking Bolt with Firing Pin Protrusion Gage - 7799735 . . . . .	8-17
8-7.	Checking Headspace with Headspace Gage 7799734 . . . . .	8-17
9-1.	Bolt Carrier Group . . . . .	9-4
9-2.	Lower Receiver Group . . . . .	9-6
9-3.	Upper Receiver Group . . . . .	9-9
9-4.	Major Groups, Assemblies and Attaching Parts . . . . .	9-12
9-5.	Sight Assembly . . . . .	9-17
11-1	Bayonet-Knife Marking and Identification of Releases . . . . .	11-1
11-2	Bayonet-Knife M7 - exploded view . . . . .	11-1
12-1.	Grenade Launcher 40-MM XM148 - left rear view . . . . .	12-1
12-2.	Special Tools and Equipment . . . . .	12-3
12-3.	Installation and Removal of Grenade Launcher . . . . .	12-4
12-4.	Clearing the Grenade Launcher . . . . .	12-7
12-5.	Controls . . . . .	12-8
12-6.	Loading . . . . .	12-9
12-7.	Cleaning Firing Pin Recess . . . . .	12-9
12-8.	Cleaning Barrel Bore . . . . .	12-10
12-9.	Unloading . . . . .	12-10
12-10.	Disassembly/Assembly of Grenade Launcher (Operator and Organizational Maintenance) . . . . .	12-13
12-11.	Disassembly/Assembly of Sight Assembly (Direct and General Support Maintenance) . . . . .	12-16
12-11A.	Disassembly/Assembly of Grenade Launcher (Direct and General Support Maintenance) . . . . .	12-19

## Precautions

### RIFLES, M16 AND XM16E1

1. Most vapors of cleaning agents are toxic if inhaled in large quantities for extended periods. Use toxic cleaning agents sparingly and only in well ventilated areas.
2. Wash hands thoroughly with soap and water after using cleaning agents. A lanolin base cream may be used after washing.
3. Only the cleaning agents in this manual and a vapor degreaser are authorized for cleaning. Before using a vapor degreaser, the following parts or components shall be removed:

STOCK ASSY, MOLDED: W/swivel (27, Fig. 9-2)  
GRIP, PISTOL: (21, Fig. 9-2)  
GUARD, HAND, GUN: R-H, and L-H. (1 & 2, Fig. 9-3)  
SWIVEL, FRONT: (10, Fig. 9-3)

When removing stock assembly and pistol grip care should be taken to prevent loss of detents and springs. (22, 23, 33 and 36, Fig. 9-3)

### LAUNCHER, GRENADE, XM148

1. Launcher should not be cocked, prior to loading.
2. Make certain trigger is extended, before cocking the launcher.
3. Do not fire launcher with front sling swivel or bayonet on the rifle.
4. When the grenade launcher safety lever is in the fire position, avoid striking or bumping the rifle or launcher.
5. Make certain launcher and rifle are unloaded and safe prior to cleaning and lubrication and disassembly.
6. For range firing or training purposes, the rifle will not be loaded. In tactical situations when the rifle is loaded, the rifle selector lever will be in the "SAFE" position to prevent inadvertent fire during grenade launching. Rifle bullets could detonate grenade projectiles in flight with resultant hazard to firer or other personnel.
7. Use extreme care when removing and installing spring or roll pins to prevent enlarging holes.

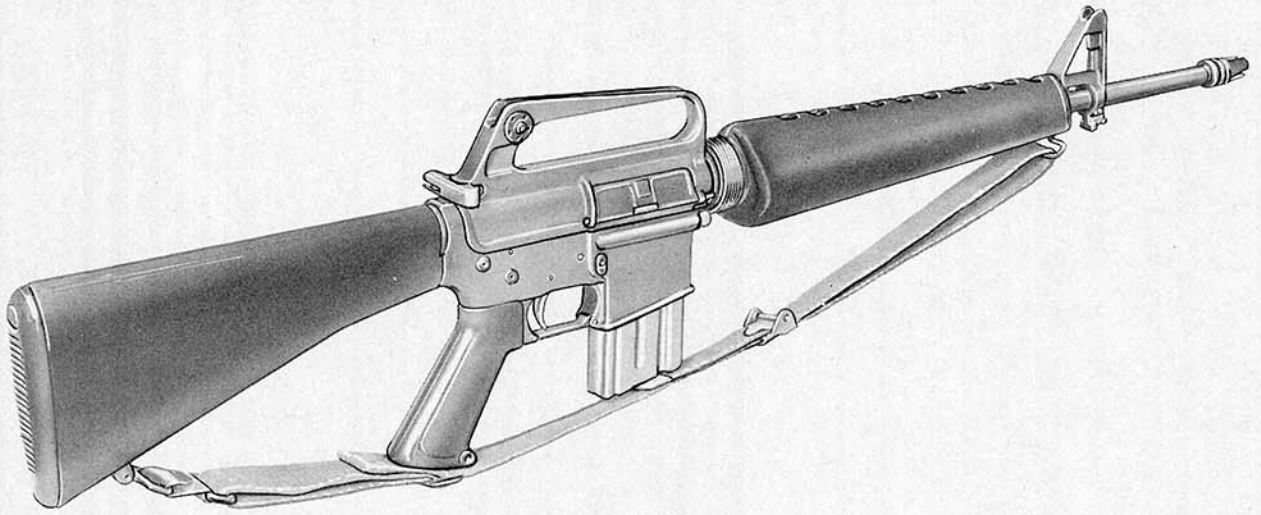

RIFLE, 5.56 MM - M16

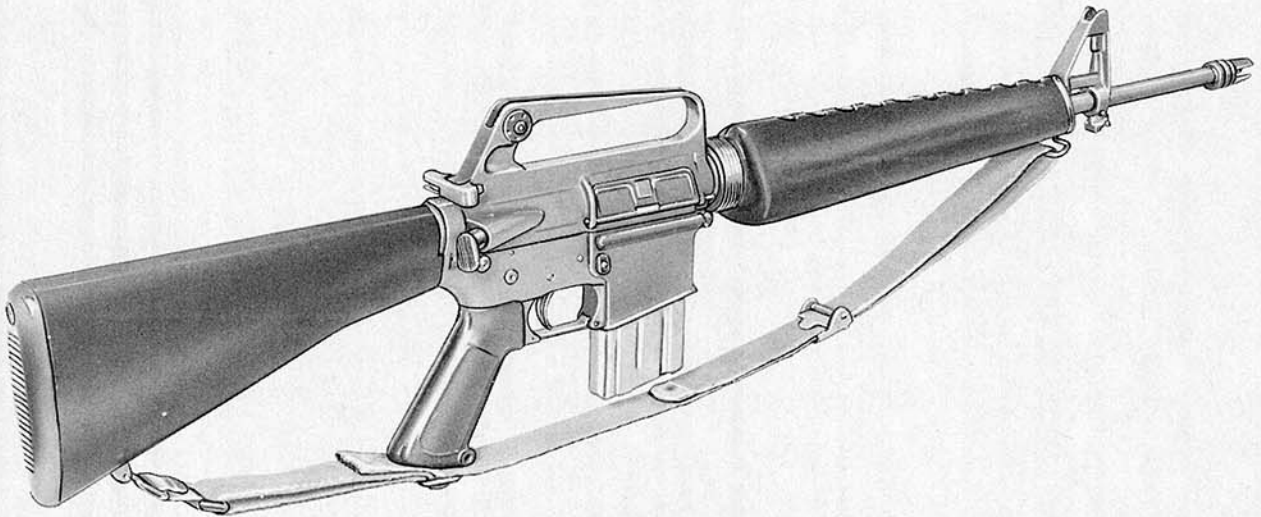

RIFLE, 5.56 MM - XM16E1

WE 13612

Figure 1-1. Rifle, 5.56-MM, M16 and XM16E1.

## CHAPTER I INTRODUCTION

### SECTION 1 PURPOSE AND SCOPE

#### 1-1. GENERAL.

1-2. This manual is published for the information and guidance of personnel responsible for Operation, Organizational, and Direct and General Support Maintenance of 5.56-mm rifles M16 and XM16E1 and 40-mm grenade launcher, XM148. Pertinent information includes tabulated data, accessories and special tools, preparation for use, storage and shipment, operating instructions, preventive maintenance and lubrication procedures, ammunition, instructions on demolition, inspections, procedures on disassembly, cleaning, repair and assembly. Also included are basic issue items, tools and replacement parts.

#### Note

THE OPERATOR (USER) AND ORGANIZATIONAL MAINTENANCE PORTION OF THIS MANUAL FOR THE RIFLES IS LISTED IN CHAPTERS I THROUGH VI AND FOR THE GRENADE LAUNCHER IN CHAPTER XII.

#### 1-3. SUGGESTIONS AND RECOMMENDATIONS.

1-4. U.S. ARMY. Use DA Form 2028 for reporting of errors, omissions and recommendations for improvement and forward direct to:

Commanding General  
Headquarters  
U.S. Army Weapons Command  
ATTN: AMSWE-SMM-P  
Rock Island Arsenal  
Rock Island, Illinois 61201

1-5. U.S. AIR FORCE. Publication deficiencies will be reported on AFTO Form 22 and processed in accordance with T.O. 00-5-1.

1-6. U.S. NAVY. Publication deficiencies will be reported on Publication Change Guide Form PRNC-NWP-5602-5 (Rev. 4-60).

### SECTION 2 DESCRIPTION

#### 1-7. DESCRIPTION.

1-8. Only XM16E1 Rifle has a forward assist assembly with associated parts. Otherwise the M16 has the same components and parts.

#### Note

The instructions in this manual when different for each model will be noted accordingly.

1-9. The rifles (figure 1-1) are light-weight, air-cooled, gas-operated, magazine-fed, shoulder or hip guns and are designed for either full automatic or semiautomatic fire. The rifles accommodate a 20-round magazine.

#### Note

FOR DESCRIPTION OF GRENADE LAUNCHER, XM148 REFER TO CHAPTER XII.

1-10. Barrel is air-cooled and is provided with a flash suppressor, and may serve as a grenade launcher and a front support for the bayonet. The barrel is surrounded by a heat resisting fibre glass material, which serves as a hand guard and forearm. The hand guard has a heat resisting inner shield. The front and rear sights are adjustable.

1-11. Butt stock is made of a durable synthetic material of high impact strength.

1-12. Rifles are easily opened by pressing the take down pin exposing the working parts, making it convenient for cleaning and inspection.

1-13. The forward assist assembly, when actuated, forces the bolt forward to the locked position (XM16E1).

1-14. Bolt locking action is one of the features of the rifles. The bolt contains locking lugs. Lugs on the barrel extension engage the bolt lugs and lock the bolt firmly in the barrel extension

\* MC I.D. 05538A

with or without cartridge in chamber. Thus the full force of the explosion of the cartridge is absorbed by the barrel extension and bolt. Receiver is made of light-weight aluminum alloys. The

safety, durability and function of the rifles is in no way reduced and the portability and logistical values greatly increased, particularly when air transport is used.

**SECTION 3  
 TABULATED DATA  
 RIFLES, M16 AND XM16E1**

**1-15. TABULATED DATA.**

**Note**

Tabulated data for the grenade launcher is listed in chapter XII.

1-16. Tabulated data pertaining to the general characteristics and performances are listed as follows:

**Weight**

M16 Rifle without magazine and sling . . . . .	6.3 lb
XM16E1 Rifle without magazine and sling . . . . .	6.5 lb
XM16E1 Rifle with grenade launcher . . . . .	10.4 lb
Sling M1 . . . . .	.4 lb
Empty aluminum magazine ( <u>20-round</u> ) . . . . .	.2 lb
Loaded aluminum magazine ( <u>20-round</u> ). . . . .	.7 lb
M16 Rifle with sling and loaded magazine ( <u>20-round</u> ) . . . . .	7.4 lb
XM16E1 Rifle with sling and loaded magazine ( <u>20-round</u> ). . . . .	7.6 lb
Telescope . . . . .	.9 lb
Bipod Assembly XM3 . . . . .	.6 lb
Bipod case . . . . .	.2 lb
Bayonet-Knife M7. . . . .	.6 lb
Scabbard M8A1 . . . . .	.3 lb

**Length**

Rifle with flash suppressor . . . . .	39 in.
---------------------------------------	--------

\* MC I.D. 05538A

Length (Continued)

Rifle with bayonet-knife . . . . .	44.25 in.
Barrel . . . . .	20 in.
Barrel with flash suppressor . . . . .	21 in.

Mechanical Features

Rifling, R.H. 6 grooves - 1 turn in 12"

Bore maximum . . . . .	.220 in.
Groove maximum . . . . .	.2245 in.
Sight radius . . . . .	19.75 in.
Trigger pull	
Maximum . . . . .	8.5 lbs.
Minimum . . . . .	5.0 lbs.
Method of operation . . . . .	Gas
Type of mechanism . . . . .	Rotating bolt
Method of feeding - magazine . . . . .	20 rds
Cooling . . . . .	Air

Ammunition

Caliber . . . . .	5.56-mm
Type . . . . .	Ball and tracer

Firing Characteristics

Muzzle velocity (approximate) . . . . .	3250 fps
Muzzle energy . . . . .	1300 ft - lb
Chamber-pressure . . . . .	52,000 psi
Cyclic rate of fire . . . . .	700/800 rds. per min.
Maximum rate of fire	
Semiautomatic . . . . .	45/65 rds. per min
Automatic . . . . .	150/200 rds. per min
Sustained rate of fire . . . . .	12/15 rds. per min
Maximum range . . . . .	2653 meters
Maximum effective range . . . . .	460 meters

**SECTION 4**  
**ACCESSORIES, SPECIAL TOOLS, AND EQUIPMENT**

**1-17. ACCESSORIES.**

1-18. Accessories are listed in Table 1-1.

**1-19. SPECIAL TOOLS AND EQUIPMENT.**

1-20. Special tools and equipment for the rifles are tabulated in table 1-2 and for the grenade launcher, in table 12-1 and are listed in Chapter IX of this manual. These tabulations contain only the tools utilized in performing the operations described in this manual.

TABLE 1-1. ACCESSORIES

Item	Identifying Number	Figure Number
BAYONET-KNIFE: M7	11010077	1-2
BIPOD ASSEMBLY: XM3	62122	1-3
CASE, BIPOD:	62309	1-4
CASE, LUBRICANT:	7790995	1-5
SCABBARD, BAYONET-KNIFE: M8A1	7268112	1-2

TABLE 1-2. SPECIAL TOOLS AND EQUIPMENT

Item	Identifying Number	References Fig.	Use
CASE, CARRYING, GAGE, BARREL:	7799809	-NI	For storing barrel erosion gage.
BRUSH, CLEANING, SMALL ARMS: bore	11686340	1-7	To clean barrel bore.
BRUSH, CLEANING, SMALL ARMS: chamber	8432358	1-12	To clean the chamber.
FIXTURE, BARREL REMOVER: vise jaws	11010032	1-9 8-4	Used with adapter to remove/install barrel nut and slip ring.
GAGE, BARREL EROSION:	7799792	1-13 8-5	To check remaining barrel life by checking barrel erosion.
GAGE, FIRING PIN PROTRUSION:	7799735	1-10 8-6	To check firing pin protrusion.
GAGE, HEADSPACE:	7799734	1-11 8-7	To gage headspace.
ROD, CLEANING, SMALL ARMS: M11E1	11686326	1-6 3-6A	Used with cleaning brush 11686340 to clean barrel bore and with cleaning brush 8432358 to clean chamber.
WRENCH, COMBINATION: barrel nut and flash suppressor	11010033	1-8 8-4	To remove and install barrel nut, slip ring and flash suppressor.

-NI NOT ILLUSTRATED

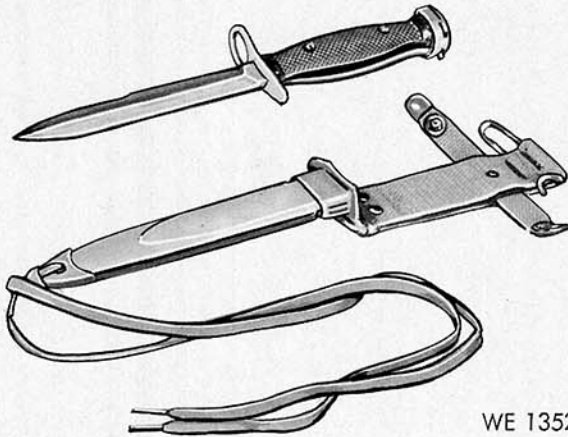

WE 13525

Figure 1-2. Bayonet Knife M7 and Bayonet - Knife Scabbard M8A1 (Fig. 3-3)

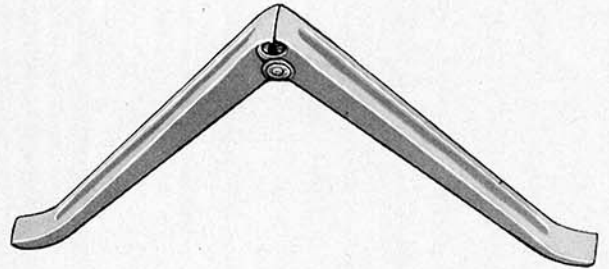

WE 13526

Figure 1-3. Bipod Assembly, XM3 (Fig. 3-3)

BRUSH AND SWAB SECTION TO BE INSTALLED ON SMALL ROD SECTIONS BEFORE INSERTION IN POCKET.

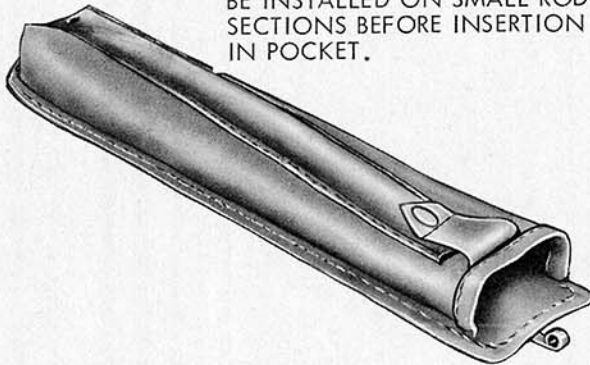

WE 13527

Figure 1-4. Bipod Carrying Case - 62309

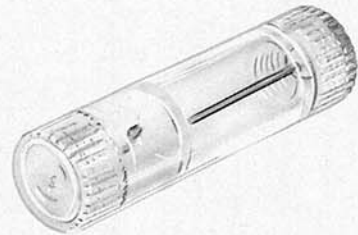

WE 13538

Figure 1-5. Lubricant Case - 7790995

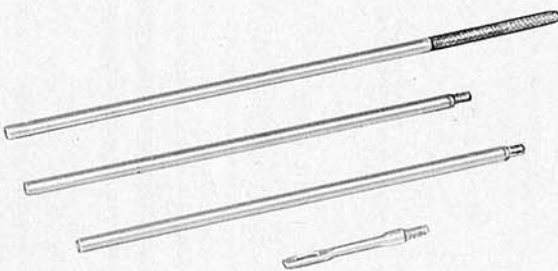

WE 13529

Figure 1-6. Small Arms Cleaning Rod - 11686326 (Fig. 3-6)

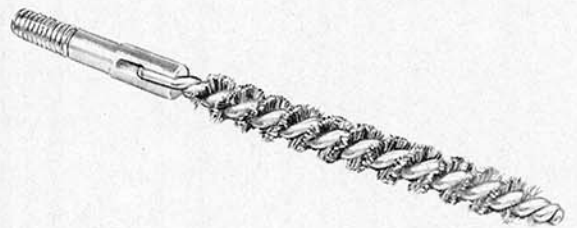

WE 13530

Figure 1-7. Small Arms Cleaning Brush - 11686340 (Fig. 3-6)

\* MC I, D. 05538A

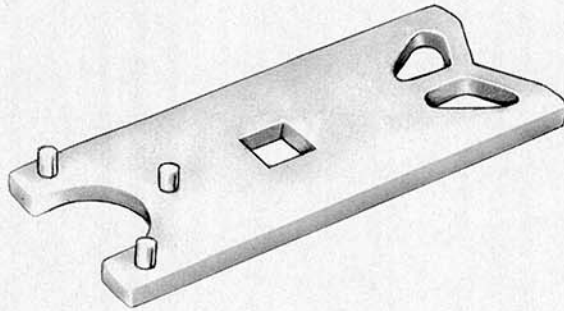

WE 13498

Figure 1-8. Combination Wrench - 11010033  
(Fig. 8-3, Pages 1 and 3)

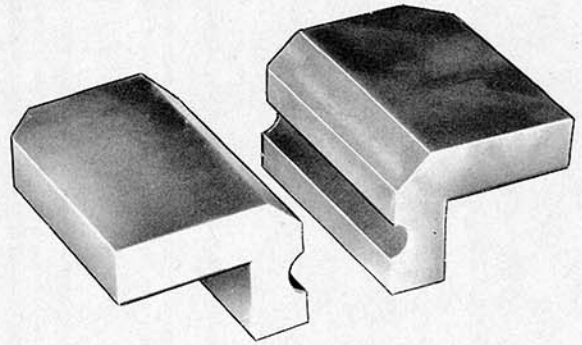

WE 13499

Figure 1-9. Barrel Remover Fixture - 11010032  
(Fig. 8-3, Pages 1 and 3)

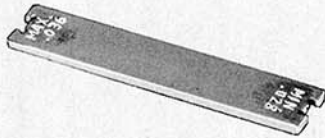

WE 13500

Figure 1-10. Firing Pin Protrusion Gage -  
7799735 (Fig. 8-6)

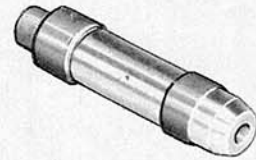

WE 13501

Figure 1-11. Headspace Gage (Field Type) -  
7799734 (Fig. 8-7)



WE 13502

Figure 1-12. Small Arms Cleaning Brush (Chamber)  
- 8432358 (Fig. 3-6A)

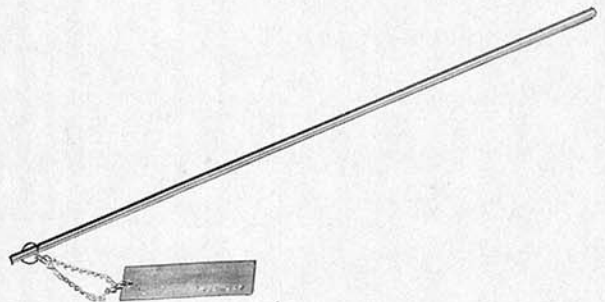

WE 13503

Figure 1-13. Barrel Erosion Gage - 7799792  
(Fig. 8-5)

## CHAPTER II PREPARATION FOR USE, STORAGE, AND SHIPMENT

### SECTION 1 PREPARATION FOR USE

#### 2-1. GENERAL.

2-2. When a new or reconditioned rifle or grenade launcher is received it is the responsibility of the officer in charge to determine whether the materiel has been properly prepared for service and to be sure it is in condition to perform its function.

2-3. All basic issue items, replacement parts, tools, and equipment will be checked with listing in Chapter IX.

2-4. A record will be made of all missing parts, tools, and equipment and of any malfunctions. Corrective action will be initiated as quickly as possible.

### SECTION 2 PREPARATION FOR STORAGE AND SHIPMENT

#### 2-5. STORAGE.

2-6. Rifles or grenade launchers to be stored are to be cleaned, dried, preserved, packaged and marked as indicated in paragraphs 2-7 through 2-13 below.

**CAUTION**

Refer to precautions on page V, when cleaning.

2-7. CLEANING. Remove dust, dirt, grit or other foreign matter from surfaces of the weapon, making certain all components are clean.

2-8. DRYING. Component parts must be thoroughly dried before preserving and packing.

2-9. PRESERVATION AND PACKAGING. Rifles must be preserved with lubricating oil, (Section 3, Chapter VIII), and grenade launcher

(par. 12-32, Chapter XII) and will be packaged in suitable containers or boxes.

2-10. MARKING. Marking instructions will be in accordance with applicable marking data.

#### 2-11. SHIPMENT.

2-12. RESPONSIBILITY. When shipping the rifle or grenade launcher, the officer-in-charge of preparing the shipment will be responsible for furnishing the materiel properly processed for shipment.

2-13. PREPARATION FOR SHIPMENT. Rifles or grenade launchers removed from storage for shipment need not be reprocessed unless inspection reveals them to be inadequately preserved.

### CHAPTER III OPERATION INSTRUCTIONS RIFLES, M16 AND XM16E1

#### 3-1. SAFETY PROCEDURE.

3-2. Clear the rifle by performing operation in figure 3-1.

#### 3-3. CONTROLS.

3-4. Refer to figure 3-2 for controls and operation of controls.

#### Note

The number in the upper left-hand corner of illustration gives the sequence of operation or disassembly.



The number in the lower right-hand corner gives the sequence of assembly.

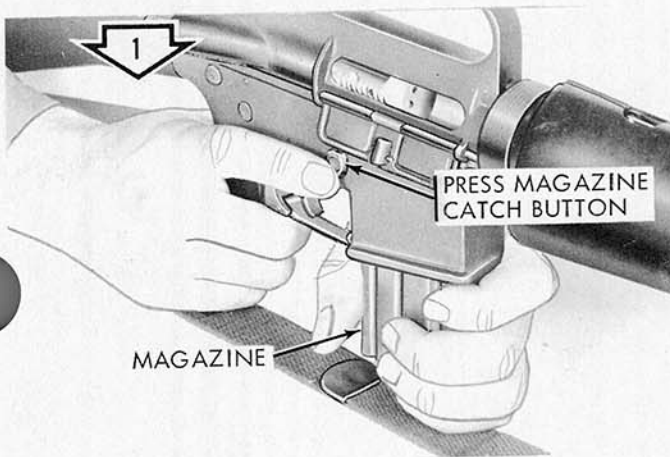

Remove magazine.

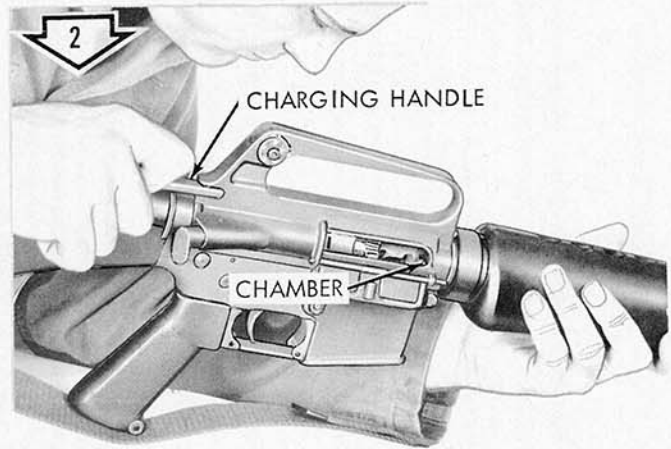

Inspect chamber.

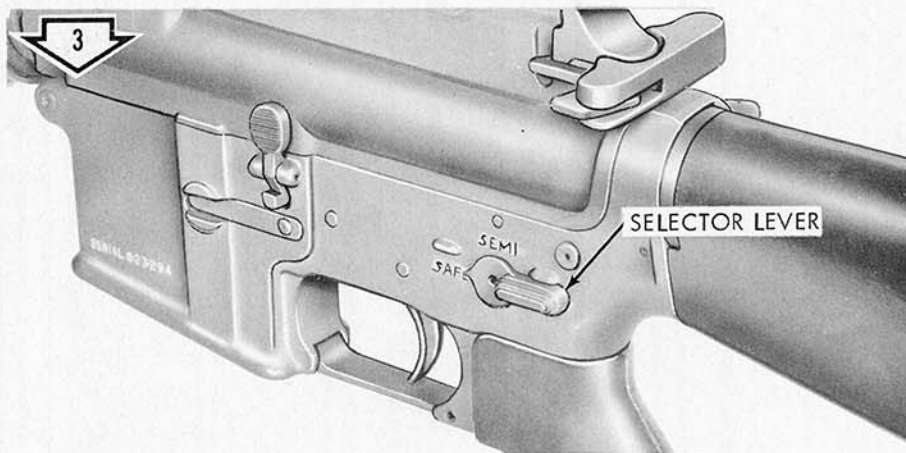

Place selector lever in SAFE position.

WE 13613

Figure 3-1. Clearing Rifle

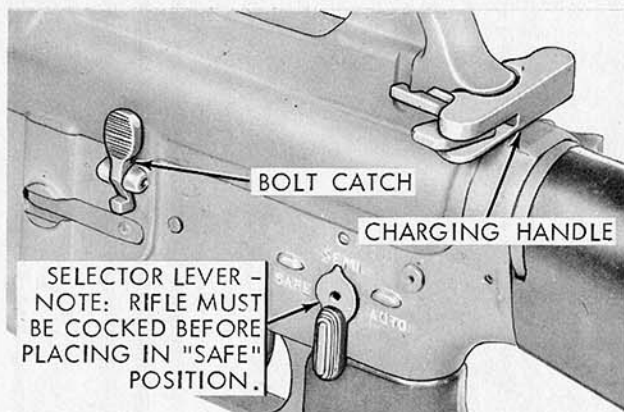

**SELECTOR LEVER** - NOTE: RIFLE MUST BE COCKED BEFORE PLACING IN "SAFE" POSITION.

**SELECTOR LEVER** - Selects "SAFE" position or type of firing.  
**BOLT CATCH** - Holds bolt and bolt carrier in open position. To engage bolt press lower tang of bolt catch. To release bolt press upper tang of bolt catch.  
**CHARGING HANDLE** - Retracts bolt and bolt carrier.

**CATCH PIN** TO BE FLUSH OR PROTRUDING. OPERATOR AUTHORIZED TO REMOVE AND INSTALL. SEE FIG. 8-2.

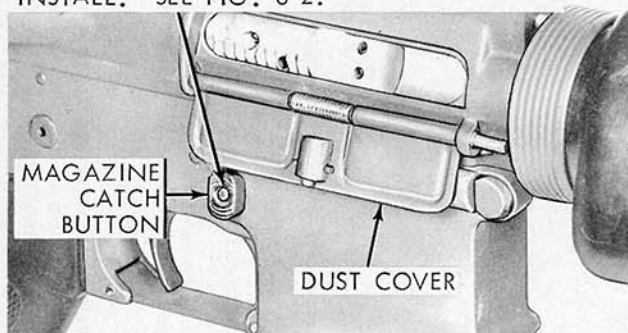

**MAGAZINE CATCH BUTTON** - Releases magazine when pressed.  
**DUST COVER** - Remains closed to keep dust out and opens automatically when bolt carrier moves rearward or forward.

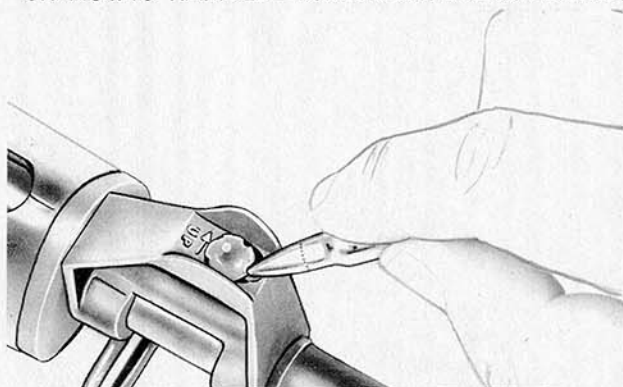

**FRONT SIGHT** - To adjust elevation; depress detent and rotate post. Each graduation (notch) moves the point of impact of the bullet 2.8 cm at 100 meters, 5.6 cm at 200 meters, etc. UP marked on sight is direction to turn post to raise line of fire.

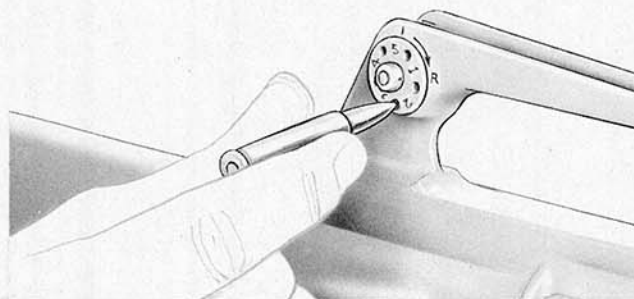

**REAR SIGHT** - Has two apertures for range. Unmarked aperture - short (0-300 meters) range. L under aperture - long (300-500 meters) range. To adjust windage - depress detent and rotate drum to desired direction. To move point of impact to right, turn drum clockwise in direction of arrow and letter R. To move left, move drum counter-clockwise. Amount of correction same as front sight.

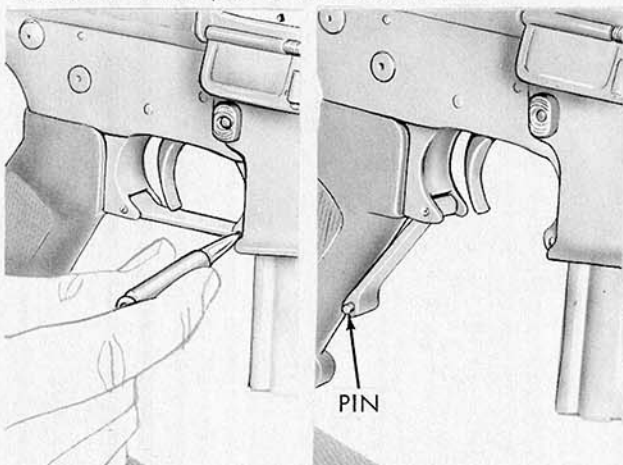

**WINTER FIRING** - Depress pin and open trigger guard.

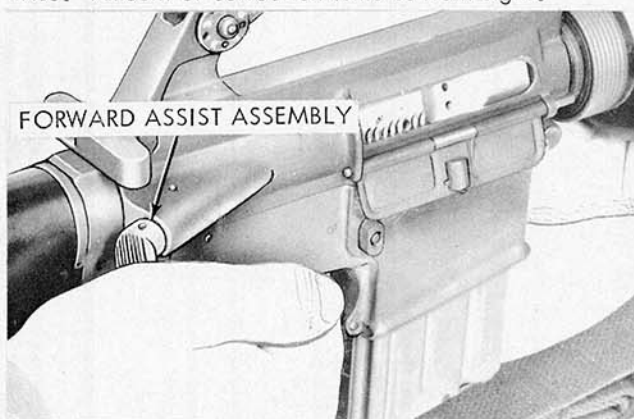

**FORWARD ASSIST ASSEMBLY**

**FORWARD ASSIST ASSEMBLY** - When bolt (XM16E1) fails to close, press forward assist assembly until bolt is moved into closed position.

WE 13614

Figure 3-2. Controls

### 3-5. CLEANING AND LUBRICATION BEFORE FIRING.

3-6. MATERIALS. The necessary cleaning materials consist of a cleaning rod, swabs, oil, solvent cleaning compound and brushes. Do not use cleaning agents other than those authorized in this manual.

#### CAUTION

When inserting rod into bore, hold at joints to prevent flexing or damage to rod.

3-7. CLEANING THE BARREL. Visually inspect the bore and chamber for condition and obstructions. Clean by pushing swabs through the bore (from the chamber to muzzle) until swabs protrude through flash suppressor.

3-8. CLEANING AND LUBRICATING THE BOLT CARRIER GROUP. The bolt carrier group may be removed, as shown in figure 3-5, for oiling and removing excessive oil. Remove any oil or dirt from the external surfaces of the bolt and bolt carrier with clean dry swabs or rag. Place a drop of oil in each of the two holes in the bolt carrier to lubricate the bolt (piston) rings. Use oil sparingly since excessive oil might form gum on the rings and impair the operation of the rifle. After lubricating the bolt rings, wipe any excess oil from the surface of the bolt carrier. A light film of grease may be applied to slides of bolt carrier and bolt cam pin area of carrier.

### 3-9. LOADING.

#### Note

Repeat operation in figure 3-1.

3-10. LOADING THE MAGAZINE. The magazine has a capacity of twenty-rounds and may be loaded with any amount up to that capacity. The magazine follower has a raised portion generally resembling the outline of a cartridge. Cartridges are loaded into the magazine so that the tips of the bullets point in the same direction as the raised portion of the follower.

#### WARNING

Prior to loading make certain selector lever is in "SAFE" position.

3-11. LOADING THE RIFLE. The magazine may be inserted with the bolt and bolt carrier opened or closed. Hold the stock of the rifle under the right arm with the right hand. Grasp the pistol grip, and point the muzzle in a safe direction. With the left hand, insert a loaded magazine into the magazine housing. Push upwards until the magazine catch engages and holds the magazine. Rap base of magazine sharply with heel of hand to assure positive retention. If the action is open, depress the upper portion of the bolt catch (figure 3-2) with the thumb of the left hand, allowing the action to close, chambering a round. If the action is closed when the magazine is inserted, pull the charging handle fully to the rear with the right hand and release it.

#### Note

Do not "ride" the charging handle forward with the right hand. If the charging handle is eased forward from the open position, the bolt may fail to lock. If bolt fails to go fully forward, use the bolt closure forward assist assembly (figure 3-2, XM16E1 only). For M16, recharge.

The rifle is now loaded, ready to fire.

#### WARNING

Make sure the selector lever is in the "safe" position, if not ready to fire.

### 3-12. FIRING.

3-13. SELECTOR LEVER. The rifle may be fired semi-automatically or fully automatically by moving the selector lever to the desired position described in 3-14 and 3-15.

3-14. SEMI POSITION. With the selector lever in this position, the rifle will fire one round each time the trigger is pulled.

3-15. AUTO POSITION. With the selector lever in this position, the rifle will continue to fire until the magazine is empty or the trigger is released. When the rifle is fired on either SEMI or AUTO, the bolt will lock in open position when the last round from a magazine has been fired.

### 3-16. STOPPAGE AND IMMEDIATE ACTION.

3-17. A stoppage is an interruption in the cycle of operation. When a stoppage occurs immediate action shall be taken to clear it.

3-18. To apply immediate action follow the sequence below:

a. Wait 10 seconds, then pull charging handle fully to the rear; observe for ejection of cartridge or cartridge case.

1. If a cartridge is ejected, release charging handle to feed a new round. Rap bolt closing forward assist assembly to assure bolt closure (XM16E1). Attempt to fire the rifle.
2. If a cartridge or case is not ejected, a failure to extract or feed has occurred.

Check for round in chamber. If chamber is empty, change magazine, reload and attempt to fire the rifle.

b. If a.1. above occurs, it may indicate a defective round, a broken firing pin, hammer spring or a bolt closure failure. (Refer to table 8-1.)

### 3-19. UNLOADING.

3-20. Repeat operation in figure 3-1.

### 3-21. INSTALLING ACCESSORIES.

3-22. Refer to figure 3-3 for installing accessories.

### 3-23. DISASSEMBLY/ASSEMBLY.

3-24. The major groups are illustrated in figure 3-4. For disassembly / assembly refer to figure 3-5.

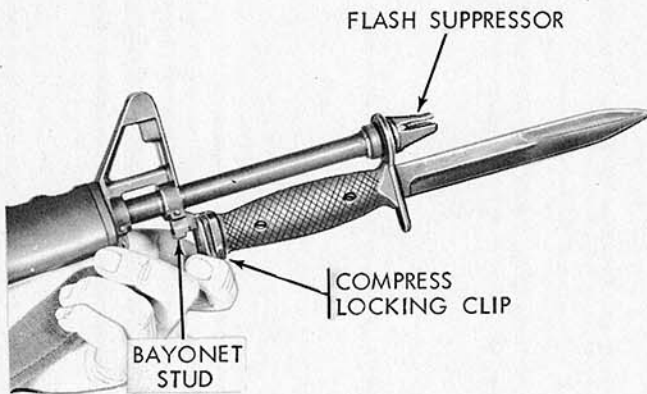

Remove/Install bayonet-knife.

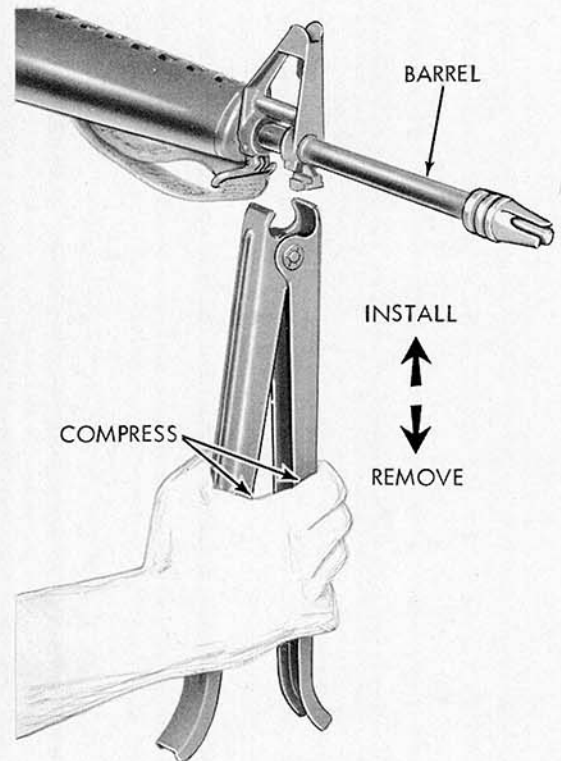

Remove/Install bipod assembly.

WE 13615

Figure 3-3. Installing Accessories.

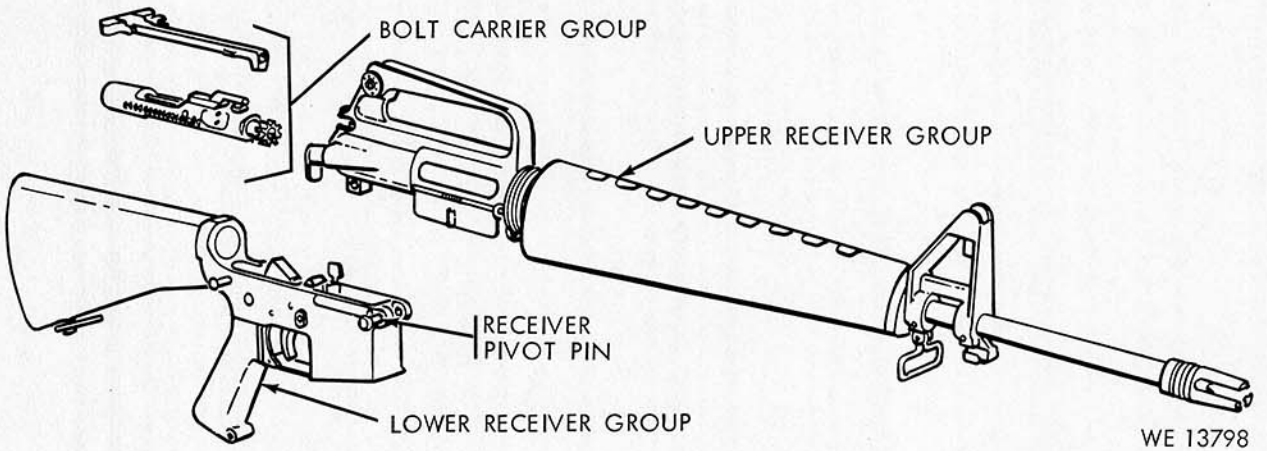
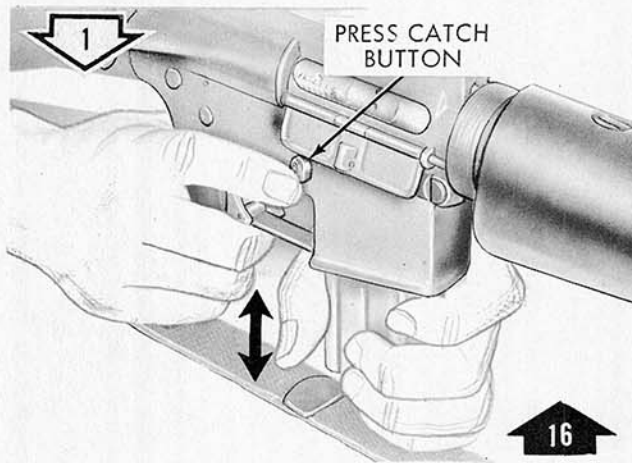

Figure 3-4. Rifles, 5.56-mm, M16 and XM16E1 Major Groups



Remove/Install magazine.



Open bolt and inspect chamber.

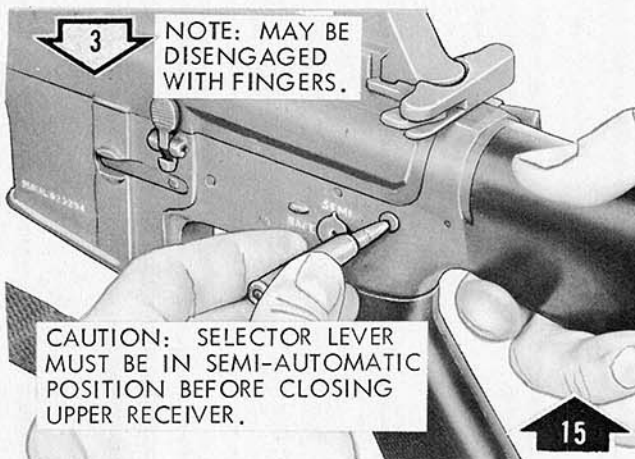

Disengage/Engage take-down pin.

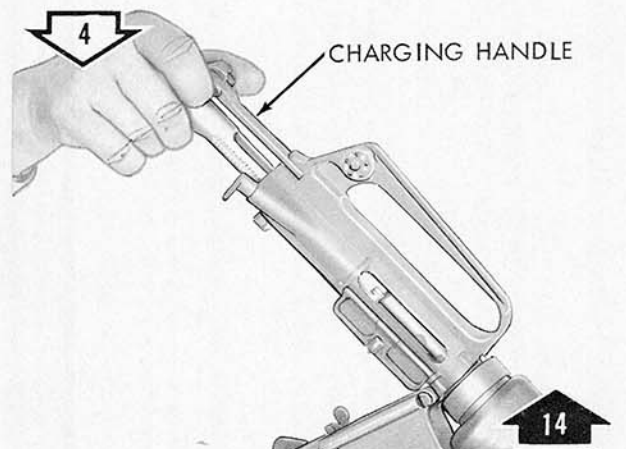

Withdraw/Insert charging handle and bolt carrier and key assembly.

WE 13799

Figure 3-5. Disassembly/Assembly of Rifle (Page 1 of 4)

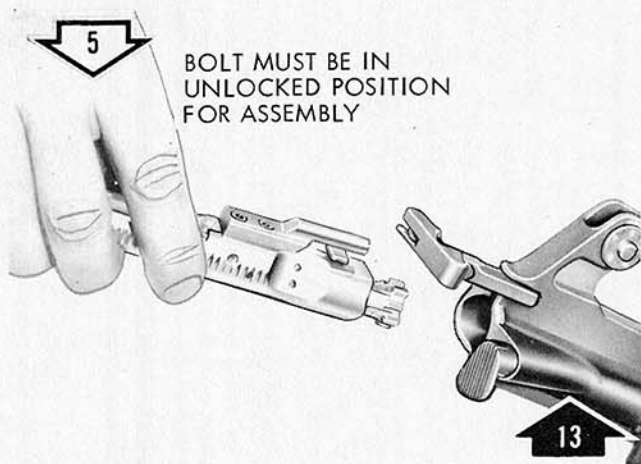

Remove/Install bolt carrier and key.

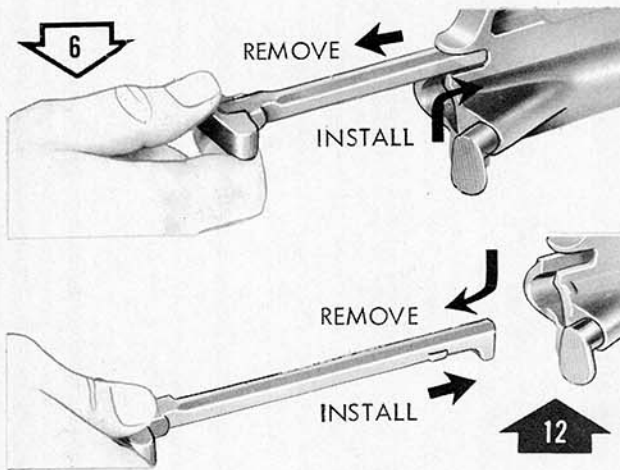

Remove/Install charging handle.

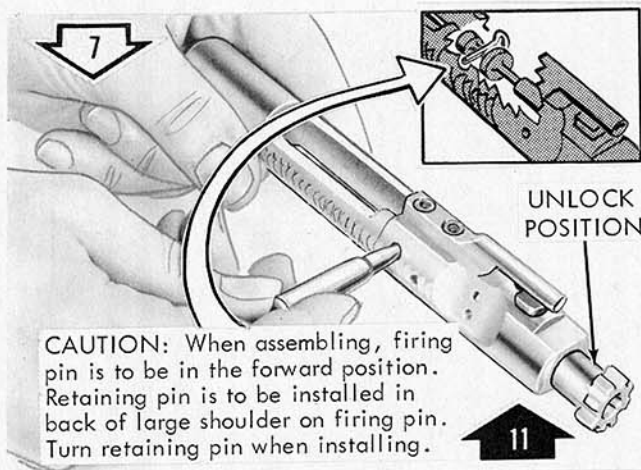

CAUTION: When assembling, firing pin is to be in the forward position. Retaining pin is to be installed in back of large shoulder on firing pin. Turn retaining pin when installing.

Remove/Install firing pin retaining pin.

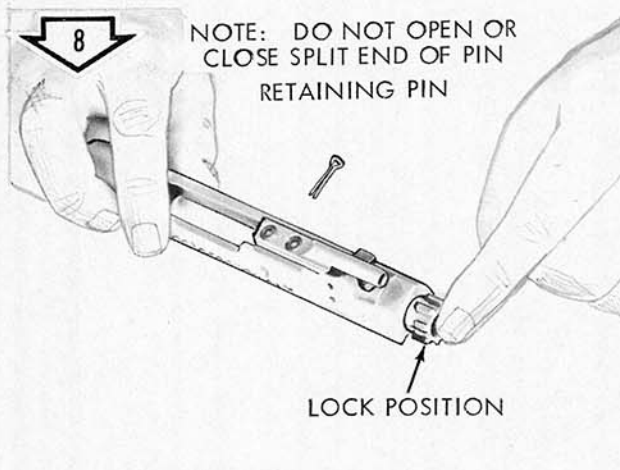

Place bolt in lock position.

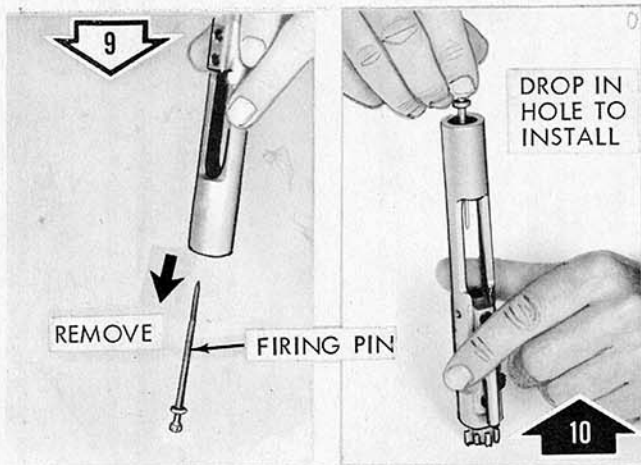

Remove/Install firing pin.

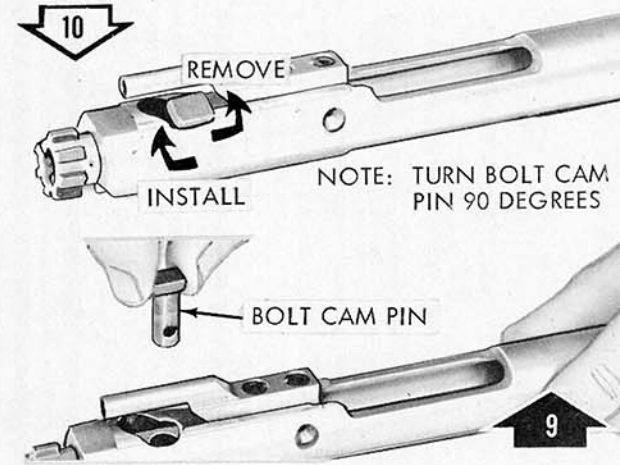

Remove/Install bolt cam pin.

WE 13616

Figure 3-5. Disassembly/Assembly of Rifle (Page 2 of 4)

11

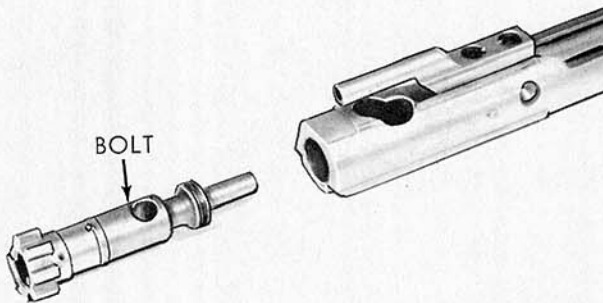

Remove/Install bolt from bolt carrier and key.

8

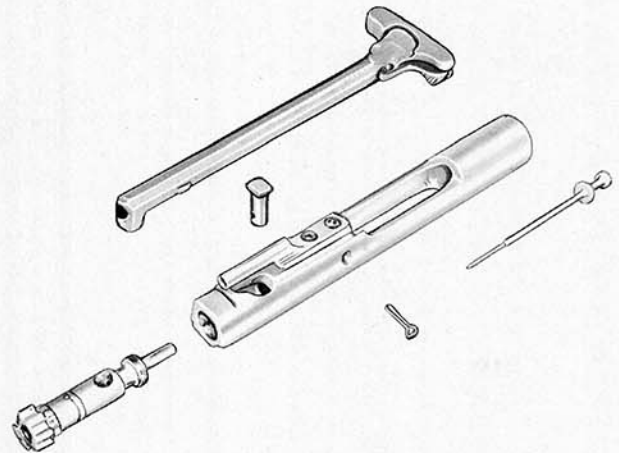

Bolt carrier group parts.

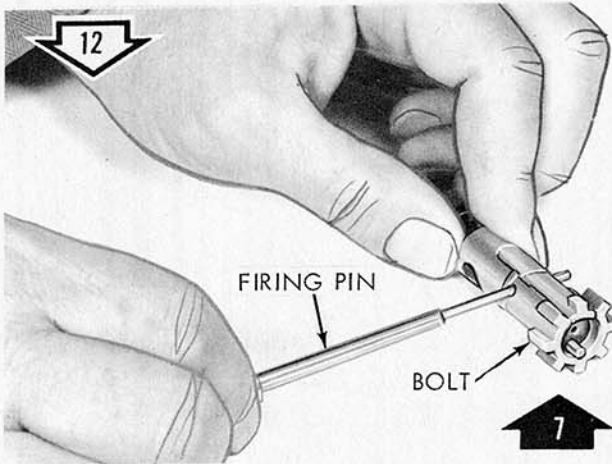

Remove/Install extractor pin.

7

13

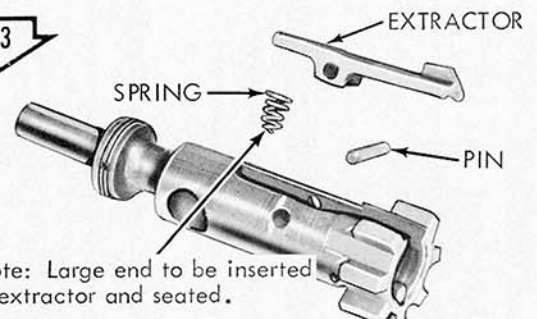

Note: Large end to be inserted in extractor and seated.

CAUTION: EXTREME CARE SHOULD BE USED TO INSURE THAT THE EXTRACTOR SPRING AND RETAINING PIN ARE NOT DEFORMED OR LOST DURING CLEANING OPERATIONS.

NOTE: REMOVAL OF THE EXTRACTOR IS AUTHORIZED FOR CLEANING PURPOSES ONLY.

Remove/Install extractor and extractor spring.

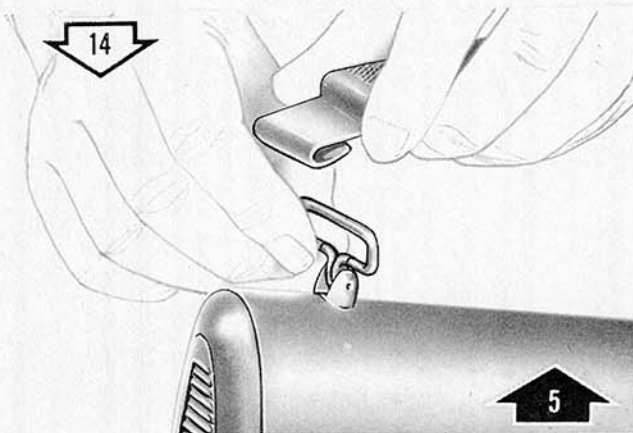

Remove/Install sling.

5

15

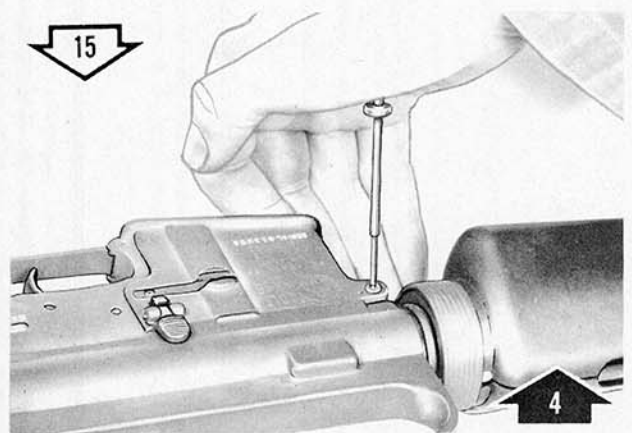

Disengage/Engage receiver pivot pin.

4

WE 13617

Figure 3-5. Disassembly/Assembly of Rifle (Page 3 of 4)

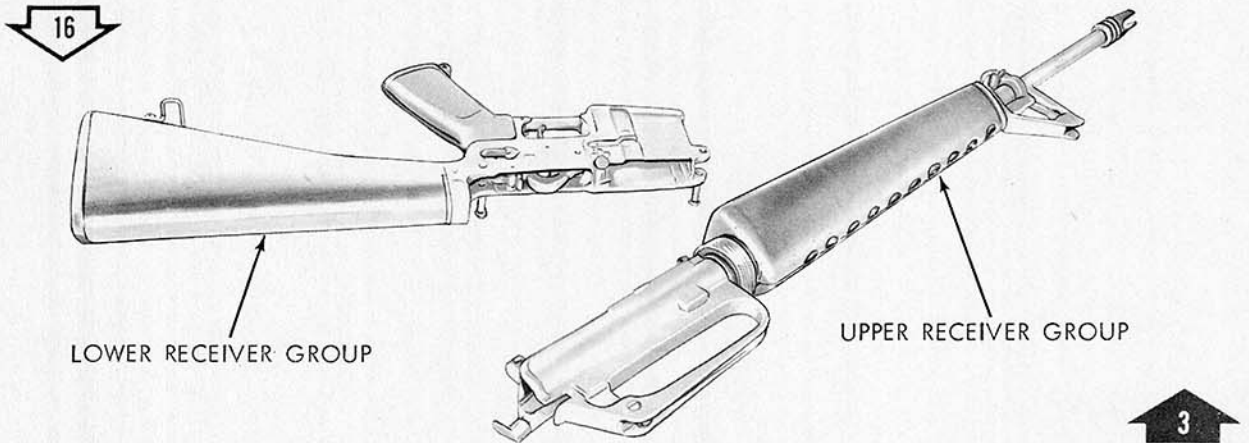

Separate/Join upper receiver and lower receiver groups.

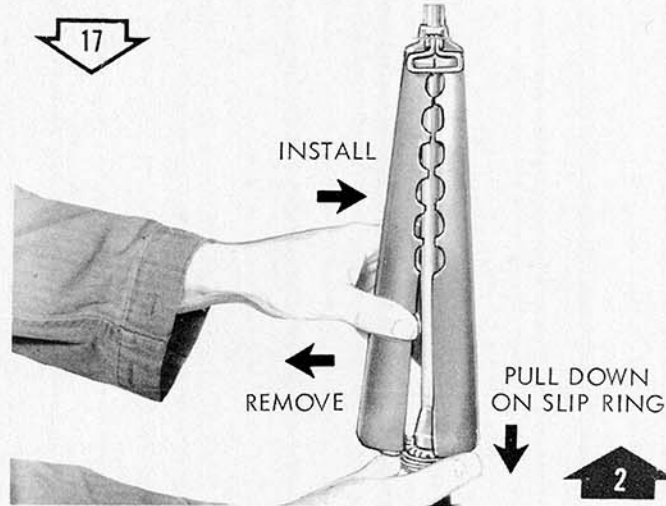

Remove/Install handguards.

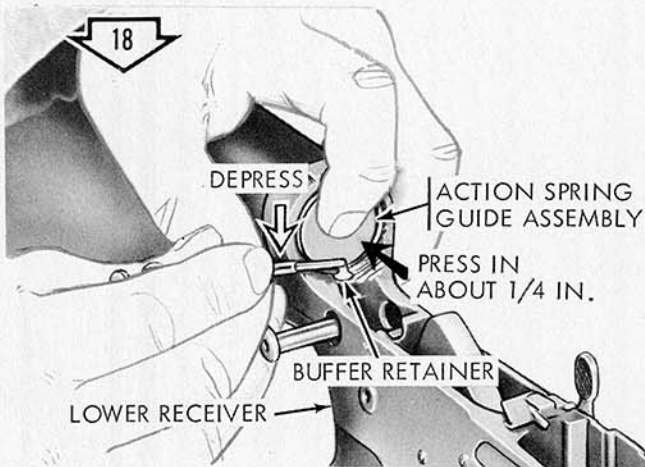

Press in action spring guide assembly, depress buffer retainer, and then release guide.

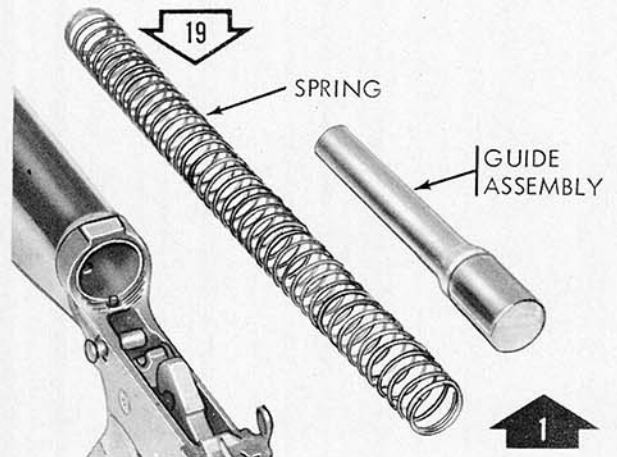

Remove/Install action spring guide assembly and action spring.

WE 13618

Figure 3-5. Disassembly/Assembly of Rifle (Page 4 of 4)

NOTE: FOR ORGANIZATIONAL MAINTENANCE ONLY

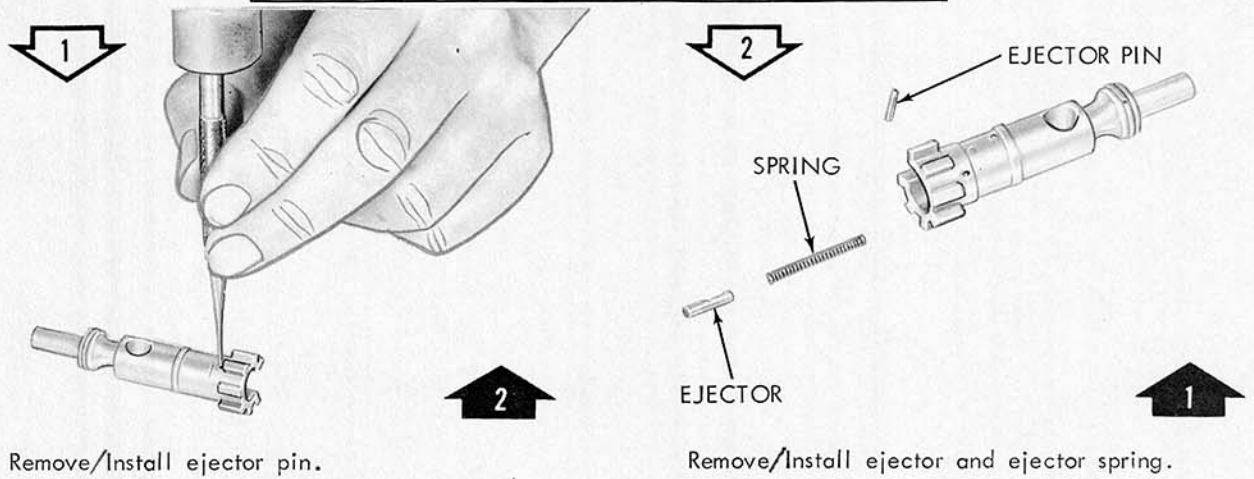

Figure 3-5A. Disassembly/Assembly of Bolt Assembly.

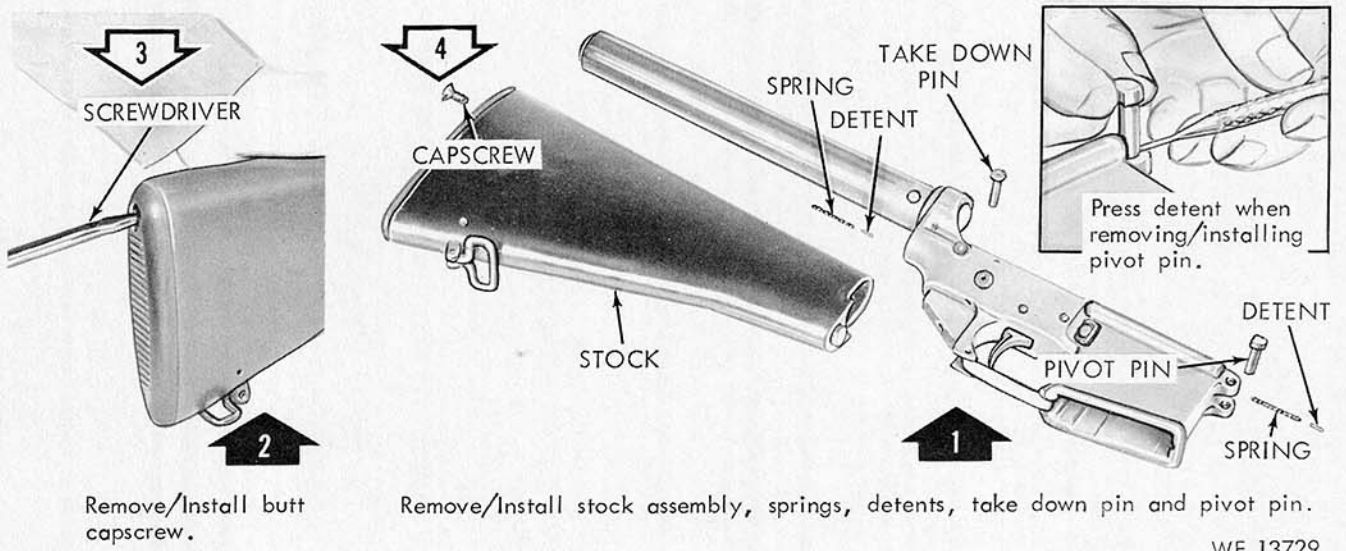
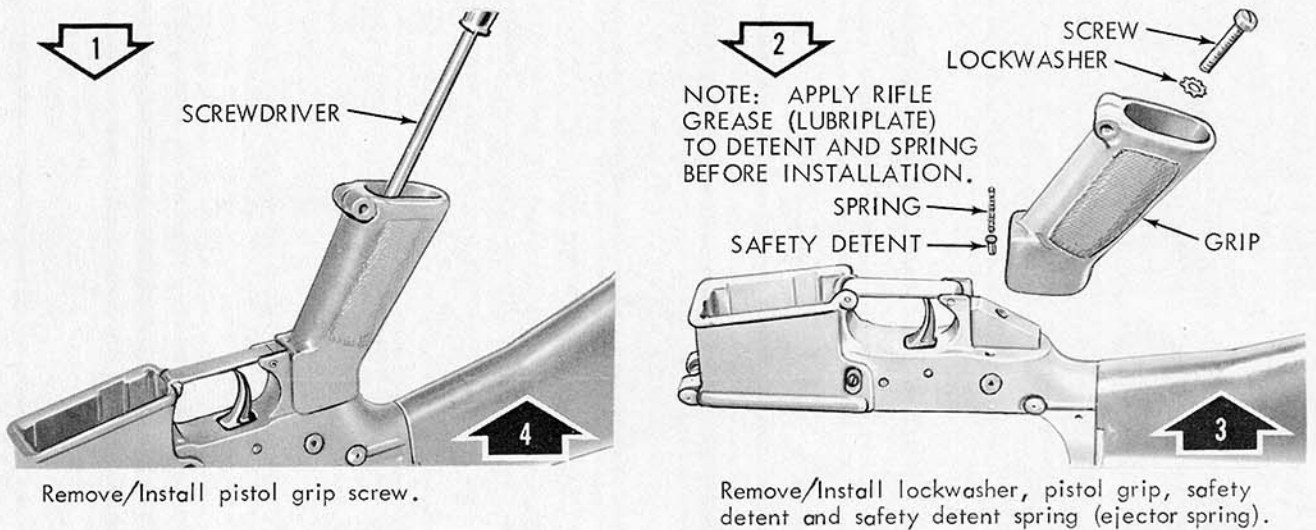

Figure 3-5B. Disassembly/Assembly of Lower Receiver Group.

WE 13729

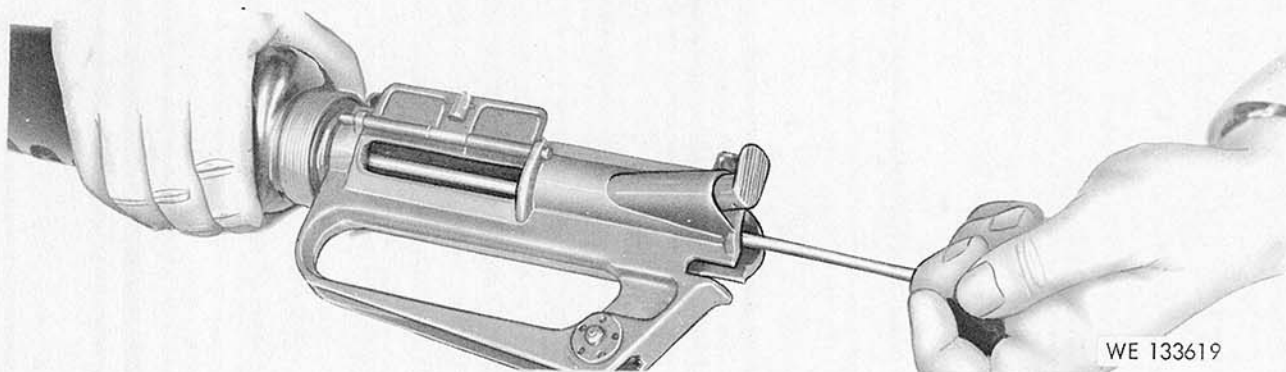

Figure 3-6. Cleaning Bore with Cleaning Rod - 11686326 and Brush - 11686340

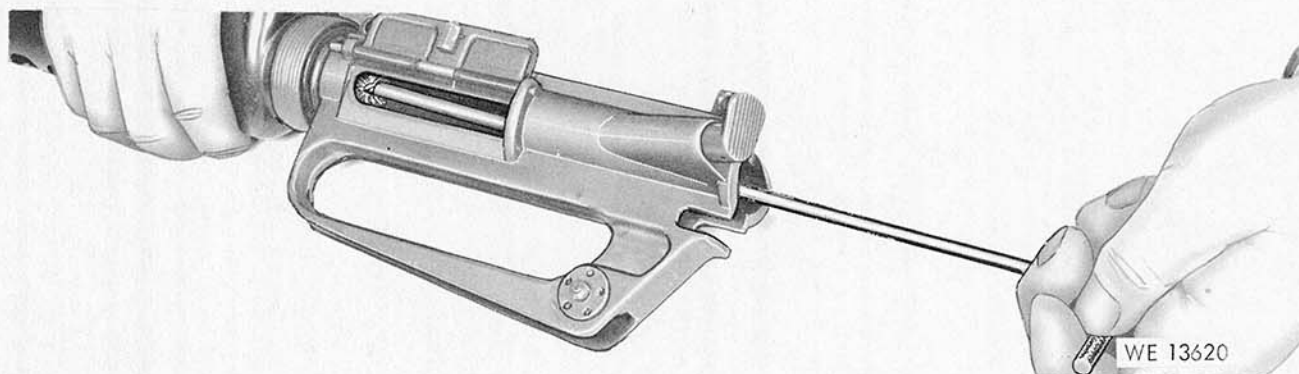

Figure 3-6A. Cleaning the Chamber

**3-25. CLEANING AND LUBRICATION AFTER FIRING.** All parts are to be cleaned with solvent cleaning compound (CR) and dried thoroughly. Apply a light coat of lubricating oil to all metal surfaces (including barrel under handguards). A light coat of rifle grease from lubricant case is to be applied to the slides of bolt carrier.

### 3-26. CLEANING AND LUBRICATING THE BARREL.

**CAUTION**

When inserting rod into bore, hold at joints to prevent flexing or damage to rod.

a. Attach the wire brush to the cleaning rod, dip in solvent cleaning compound, and brush the bore thoroughly (figure 3-6). Brush the bore from chamber to muzzle using straight through strokes.

**Note**

Do not reverse direction of brush while in bore.

Push the brush through the bore until it extends beyond the muzzle. Continue until the bore is well covered with compound. Remove the brush from the cleaning rod, and dry the bore by pushing through clean dry patches. Continue until patches come out clean and dry.

b. After cleaning, lubricate the bore with a lightly oiled patch to prevent corrosion and pitting. Lightly oil the lugs in the barrel extension.

### 3-26.1 CLEANING THE CHAMBER.

a. Attach chamber cleaning brush to cleaning rod section. Dip brush in solvent cleaning compound and insert in chamber (fig. 3-6A).

b. Use five reciprocating plunge strokes and three rotational (360°) motions.

c. Remove brush and dry chamber with cleaning swabs.

### 3-27. CLEANING AND LUBRICATING THE BOLT CARRIER GROUP.

a. Remove the bolt carrier group from the upper receiver group. Field strip the bolt carrier group. Wash all external surfaces with a patch saturated in solvent cleaning compound.

b. Using a small brush dipped in solvent cleaning compound, scrub all carbon deposits and dirt from the locking lugs of the bolt.

**CAUTION**

Brush the face of the bolt, paying particular attention to area behind the rings and under the face of extractor. Do not attempt to remove discoloration caused by heat.

c. Clean the carrier key with the bore brush (figure 3-7A). A used or worn brush should be used, if available.

d. Using a small brush dipped in bore cleaner, scrub the extractor and well to remove carbon. Removal of extractor spring will be accomplished only if spring is damaged.

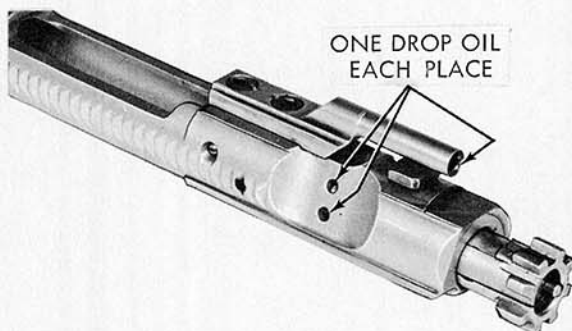

WE 13621

Figure 3-7. Oiling Bolt Rings

e. When dry, place a drop of oil in each hole on the bolt rings and gas tube (figure 3-7). Add a light coat of oil to all surfaces of bolt and bolt carrier.

f. During cleaning, inspect bolt for cracks or fracture in the bolt cam pin hole area.

**CAUTION**

Excessive oil applied to firing pin recess of bolt will result in a light struck primer, therefore, causing a failure to fire. Also avoid application of excessive oil to components subjected to carbon deposits.

**3-27A. CLEANING AND LUBRICATING THE UPPER RECEIVER.**

a. Clean the upper receiver of powder fouling with solvent cleaning compound (CR).

b. Clean the protruding gas tube in receiver with the bore brush attached to section of cleaning rod (figure 3-7B). The top of gas tube can be cleaned by inserting rod and brush in the back of receiver. The sides and bottom of gas tube can be cleaned from bottom of receiver.

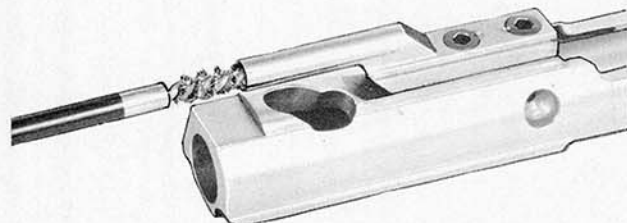

WE 13622

Figure 3-7A. Cleaning Carrier Key

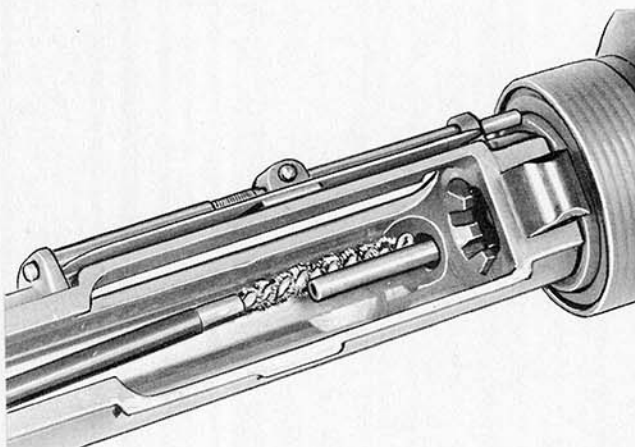
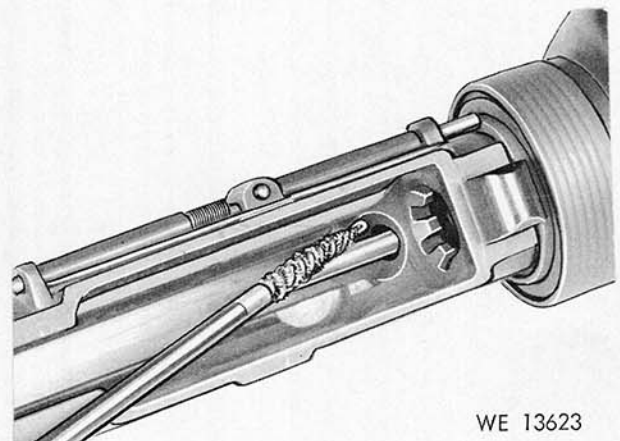

Figure 3-7B. Cleaning Gas Tube in Receiver.



WE 13623

**Note**

Do not use any type of abrasive material to clean the gas tube.

**3-28. CLEANING AND LUBRICATING THE LOWER RECEIVER GROUP.**

- a. Wipe any particles of dirt from the trigger mechanism with a clean patch or brush.
- b. Place a drop of oil on each of the pins for lubrication.
- c. Components of the lower receiver group that are coated with carbon residue will be cleaned using solvent cleaning compound (CR) and an artist brush or similar brush. Use a scrubbing action, this will remove nearly all carbon residue and foreign material. Drain solvent cleaner from lower receiver cavity and wipe dry. Utilize the opposite end of brush with a piece of cloth wrapped around to get into the hard to get at places. After the lower receiver has been dried, a light coat of oil should be applied to the interior and all components.

**3-28A. CLEANING OF SCABBARD M8A1 AND SLING.**

- a. To prevent mildew, shake out and air sling and scabbard at frequent intervals. Mildewed canvas is cleaned by scrubbing with a dry brush.
- b. If mildew is present, examine fabric carefully for evidence of rotting or weakening of fabric by stretching and pulling. If fabric shows indication of loss of tensile strength, turn in for replacement.
- c. If water is necessary to remove dirt, it must not be used until mildew has been removed. Oil and grease may be removed by scrubbing with issue soap and water. Rinse well with water and dry.

**CAUTION**

At no time is gasoline or any solvent to be used to remove oil or grease from canvas. Canvas should be dried thoroughly.

**3-28B. CLEANING AND MAINTENANCE OF BAYONET-KNIFE, M7.**

- a. Clean bayonet-knife of dirt and/or grease.
- b. Release shall work freely and return to lock position.

c. Nicks, dents, and burs shall be removed by organizational support.

**3-29. FUNCTION CHECK.**

**Note**

Remove magazine.

3-30. A complete function check of the rifle consists of checking the operation of the rifle while the selector lever is in the SAFE, SEMI, and AUTO positions. The following sequence is used for a rapid, complete check. Any portion of the check may be used alone to determine the operational condition of any specific fire selection.

**Note**

Disengage take down pin and open receivers. Hammer shall be in the cocked position.

a. SAFE position. Pull trigger, hammer shall not fall.

b. SEMI position. Pull trigger, hammer should fall. Hold trigger to rear, recock hammer and release trigger. Hammer should transfer from hammer hooks and disconnect to the hammer and sear engagement.

c. AUTO position. Pull trigger, hammer should fall. Hold trigger to the rear and recock the hammer. Hammer is now under the automatic sear. Still holding trigger to the rear, push forward on automatic sear. The hammer should fall. Still holding trigger to the rear, recock hammer, release trigger and push forward on automatic sear. Hammer should transfer to the sear engagement. Move selector lever to "safe" or "semi" position. Close receivers and engage take down pin.

**CAUTION**

Failure to move selector lever to "safe" or "semi" position before closing receivers, will damage automatic sear.

d. SEMI position. Pull the charging handle to the rear. Inspect the chamber for safety and release charging handle. Pull the trigger. Hammer should fall.

## CHAPTER IV PREVENTIVE MAINTENANCE

### 4-1. GENERAL.

4-2. Preventive maintenance is the systematic care, inspection, and servicing of equipment to maintain it in serviceable condition, prevent breakdowns, and assure maximum operational readiness. The operator's role in the performance of preventive maintenance service is:

a. To perform the daily service each day the rifle is operated.

b. To assist the organizational maintenance mechanics in the performance of any other sched-

uled periodic services specified by pertinent technical manuals.

### 4-3. RESPONSIBILITY.

4-4. Operators are responsible for assigned equipment. Squad, flight, or platoon leaders are charged supervisory responsibility for equipment pertaining to their commands.

### 4-5. SPECIFIC PROCEDURES.

4-6. Table 4-1 gives the specific procedures to be performed on the rifle by the operator for each daily service.

TABLE 4-1. PREVENTIVE MAINTENANCE CHECKS AND SERVICES

Interval & Sequence No.			Operator		
Before Firing	During Firing	After Firing	Daily Schedule		
			Item to be Inspected	Procedures	Paragraph References
1			Rifle	Wipe oil from bore and chamber.	Para. 3-7
2*			Rifle	Retract bolt to assure free movement between bolt carrier and gas tube.	Para. 3-1
3*			Rifle	Hand function to assure proper operation.	Para. 3-29
4*			Rifle	Check magazine for positive retention and functioning of bolt catch.	Para. 3-11
		5*	Rifle	Clean and lubricate. Particular attention shall be given to clean bolt carrier key.	Para. 3-25 Para. 3-27

\*Will be performed weekly if the daily schedule is not otherwise performed as a result of firing.

## CHAPTER V AMMUNITION SECTION I RIFLES

### 5-1. GENERAL.

5-2. The ammunition (figure 5-1) for the 5.56-mm rifles M16 and XM16E1 is classified as small-arms ammunition and is issued in the form of a complete round. A complete round (cartridge) consists of all the components necessary to fire the weapon once, that is, projectile (bullet), cartridge case, propellant, and primer.

### 5-3. CLASSIFICATION.

5-4. Based upon type of projectile, ammunition when available for use in this rifle will be classified as outlined in paragraphs a through d.

a. Ball cartridge, for use against light materiel targets and personnel.

b. Blank cartridge, for simulated fire, in maneuvers, and in firing salutes.

c. Tracer cartridge, for observation of fire, incendiary effect, and signaling.

### 5-5. IDENTIFICATION.

5-6. GENERAL. The type, caliber, model, and ammunition lot number, including the symbol of the manufacturer are necessary for complete identification of small-arms ammunition. Ammunition for the 5.56-mm weapon is completely identified by its appearance, the painting of the bullet tip, and the markings on the packing containers.

5-7. STAMPING. Because of its small size, the marking on small-arms ammunition consists of the stamping of the manufacturer's initials and year of manufacture on the base of the cartridge case.

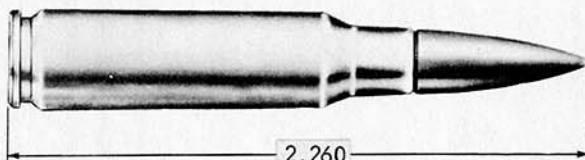

ORD D864

Figure 5-1. Cartridge, 5.56-MM, Ball, M193

5-8. TYPES. When removed from their original packing containers, the cartridges may be identified by physical characteristics as follows:

Type	Distinguishing Characteristics
Ball	Gilding metal or gilding metal clad steel jacket on bullet (no markings).
Blank	Not known - under development.
Tracer	Tip of bullet is painted orange for a distance of approximately 5/16 inch.

5-9. GRADES. Small-arms ammunition is graded primarily on the qualities which make the lot especially suited for use in a particular class of weapons; for example, a lot of ammunition assigned grade R is especially suited for use in rifles. Current grades of all existing lots of small-arms ammunition are established by the Army Materiel Command and are published in Department of the Army Technical Bulletin, TB 9-AMM-4. Only those lots of appropriate grade will be fired. Grade 3 indicates unserviceable ammunition that will not be issued or fired or cartridges for which the ammunition lot number has been lost. However, ammunition placed in grade 3 because of loss of ammunition lot number, but which can be identified as having been in serviceable lots issued to a specific organization, may be reissued after visual inspection, but only for local training purposes. When cartridges are removed from original packings, they should be marked or tagged so that the ammunition lot number may be preserved.

5-10. MODEL. To identify a particular design, a model designation is assigned at the time the item is classified as an adopted type. This model designation becomes an essential part of the standard nomenclature and is included in the marking on the packing container. The present system of model designation consists of the letter "M" followed by an arabic numeral;

for example, "M61". Modifications are indicated by adding the letter "A" and appropriate arabic numeral. Thus, "M61A" indicates the first modification of an item for which the original designation was "M61". Similarly, a system applied to development items involves the use of a "T" or "XM" designation to indicate the basic design and an "E" to indicate modifications thereof. Thus, "T102E1" would indicate the first modification of a development item originally designated "T102".

5-11. AMMUNITION LOT NUMBER. When ammunition is manufactured, an ammunition lot number, which becomes an essential part of the marking, is assigned in accordance with pertinent specifications. This lot number is marked on all packing containers. Since it is impracticable to mark the ammunition lot number of each cartridge, every effort should be made to maintain the ammunition lot number of cartridges removed from their original packings. Cartridges for which the ammunition lot number has been lost automatically are classified grade 3.

#### 5-12. CARE, HANDLING, AND PRESERVATION.

a. Ammunition for the 5.56-mm rifle (small-arms), as compared with other types of ammunition, is not dangerous to handle.

b. Ammunition is packed to withstand conditions ordinarily encountered in the field. Care must be observed to keep packings from becoming broken or damaged. All broken packings must be repaired immediately and careful attention given to the transfer of all markings to the new parts. The ammunition may be packed in metal-lined wooden boxes or metal boxes. If the damaged box contains a metal liner, it should be air-tested and sealed, providing that equipment for this work is available.

c. When necessary to store ammunition in the open, raise it on dunnage at least six inches from the ground and protect it with paulin or other cover, leaving enough space for the circulation of air. Where practicable, dunnage strips should be placed under each layer of boxes. Suitable trenches should be dug to prevent water from running under the pile.

d. Since ammunition and explosives are adversely affected by moisture and high temperature, due consideration should be given to (1) and (2) below.

- (1) Do not open boxes until ammunition is to be used. Ammunition removed from

airtight containers, particularly in damp climates, is apt to corrode, thereby rendering the ammunition unserviceable.

- (2) Protect ammunition from high temperature and direct rays of the sun. More uniform firing is obtained if rounds are at the same temperature. The combination of high temperatures and a humid atmosphere is particularly detrimental to the stability of the propellant and to tracer mixtures in tracer ammunition.

e. Do not attempt to disassemble the cartridge or any of its components.

f. The use of oil or grease on cartridge is prohibited.

g. Ammunition should be protected from sand, mud, moisture, frost, snow, ice, grease, and other foreign matter. If it gets wet or dirty, it should be wiped off at once. If corrosion forms on the cartridges, it should be wiped off with a clean dry cloth. However, cartridges should not be polished to make them look better or brighter.

h. Brass cartridge cases are easily dented and should be protected from hard knocks or blows. Dented cartridge cases may cause incomplete obturation, jamming in the chamber, and difficulty in extraction.

i. Ammunition, when stored, should be segregated by caliber, type, and ammunition lot number.

j. When only a part of a box of ammunition is used, the ammunition remaining in the box should be protected against unauthorized handling and use by firmly fastening the box cover in place.

#### 5-13. AUTHORIZED ROUNDS.

5-14. The ammunition authorized for use in the 5.56-mm rifles M16 and XM16E1 is listed in table 5-1. Standard nomenclature, which is used in the listing, completely identifies each item except for ammunition lot number. Only authorized cartridges will be used in the weapon; unauthorized assembly and use of cartridges are extremely dangerous. Ordinarily, issue of this ammunition is in proportion by types to meet tactical requirements, so that substitution of unauthorized rounds in the field is not required.

TABLE 5-1 AUTHORIZED ROUNDS

Standard Nomenclature	Complete round		Projectile	
	Length (in.)	Weight (grains) (approx)	Length (in.)	Weight (grains) (approx)
CARTRIDGE, 5.56-MILLIMETER: ball, M193	2.26	179	0.755	55
CARTRIDGE, 5.56-MILLIMETER: tracer, XM196	2.26	177	0.895	54
*CARTRIDGE, 5.56-MILLIMETER: blank, XM200				

\* Items are under development.

#### 5-15. PREPARATION FOR FIRING.

5-16. After removal from packing materials, cartridges for this weapon are ready for firing. Cartridges prepared for firing, but not fired, will be returned to their original packings or packed in suitable packing boxes. The packing boxes should be appropriately marked to indicate the nomenclature of the cartridges, the quantity of cartridges therein, and the appropriate ammunition lot number. Such cartridges will be used first in subsequent firings in order that stocks of opened packings may be kept at a minimum.

#### 5-17. PRECAUTIONS IN FIRING.

5-18. The precautions in "a" through "k" below should be closely observed in order to prevent injury to personnel or damage to materiel.

a. The cartridges should be free of sand, mud, moisture, frost, snow, ice, grease, or other foreign matter before loading into the magazine.

b. Ammunition which is seriously corroded should not be fired.

c. Brass cartridge cases are easily dented and should be protected from hard knocks and blows. Dented cartridge cases may cause incomplete obturation, jamming in the chamber and difficulty in extraction.

d. Cartridges which have been seriously damaged, or those having loose bullets, should not be used.

e. Before firing, blank cartridges should be visually inspected for evidence of any foreign matter within the cartridge case mouth. Any foreign matter therein would be expelled as a projectile in firing.

f. Blank cartridges should not be fired at a representative enemy at distances less than 20 feet. The unburned propellant grains may cause injury within this distance.

g. Ammunition should not be fired unless it has been identified by ammunition lot number and the grade.

h. Do not fire cartridges which have become overheated due to exposure to the direct rays of

the sun or other sources of high temperature. Such cartridges, if fired, may develop hazardous chamber pressures.

i. If, at the time firing is interrupted, a cartridge is in the chamber of a very hot weapon, the cartridge should be removed promptly to prevent the possibility of a cook-off.

j. Misfires and hangfires will be handled as indicated in par. 3-16 through 3-18. Specific instructions, for M16 and XM16E1 rifle, are to

wait ten seconds from the failure to fire before retracting bolt to remove the round.

5-19. PACKING AND MARKING.

5-20. PACKING. The individual cartridges for this weapon are packed in cartons (table 5-2). The cartridges are then packed into metal boxes in wirebound wooden boxes.

5-21. Refer to applicable manuals for marking instructions.

TABLE 5-2. PACKING DATA FOR 5.56-MM AMMUNITION

	Volume (cu ft)	Weight (lb)
Packed 20/carton, 36 carton (720)/per metal box M2A1, 2 box (1440 cartridge)/wirebound box. Dimensions of box; 14-1/2 x 12-3/4 x 8-3/8	0.85	59.0

SECTION 2  
 GRENADE LAUNCHER

5-22. GENERAL

a. This section covers technical and general information pertaining to the authorized rounds (cartridges); their care, handling, and preservation; preparation for firing; precautions in firing and packing of ammunition for the grenade launcher.

b. The ammunition for the grenade launcher is of the fixed type and is identified as shown in figure 5-2.

5-23. AMMUNITION LOT NUMBERS. At the time of manufacture, every ammunition item is assigned a lot number. An ammunition "lot" consists of a number of items manufactured from the same materials under similar conditions which may be expected to function in a like manner. The ammunition lot number consists, in general, of the loading plant's initials or symbol and the number of the lot. The number of a lot may be either a basic number or a basic number and a subnumber separated by a hyphen. The

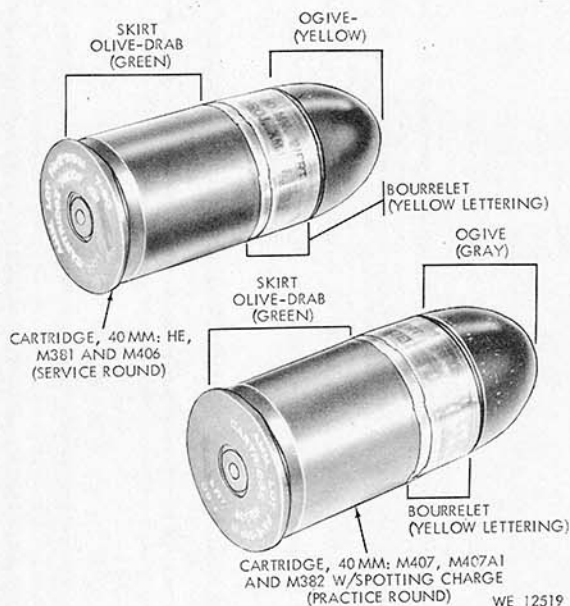

Figure 5-2. Cartridges used with grenade launcher XM148.

use of the lot number is required in all references to specific items in reports and records.

5-24. MODEL NUMBER. When a particular design is adapted as a standard, the letter M and an arabic numeral indicate the model designation. When this design has been accepted only for limited procurement and service use, the model designation is indicated by the letters XM and an arabic numeral. Modifications to the XM model designation are indicated by the addition of the letter E and an arabic numeral. In such cases, if the design subsequently should be standardized, the M designation is assigned; hence, some lots may be encountered still bearing the original XM designation. The M designation is obtained by simply dropping the X and any E modifiers in the XM designation. In cases where further modifications are made to an adopted item having the M designation, these changes will be indicated with the addition of the letter E and an arabic numeral and when one of the modifications is again adapted as a standard the letter E is replaced by the letter A and the appropriate arabic numeral.

#### 5-25. CARE, HANDLING, AND PRESERVATION.

a. Ammunition is packed to withstand conditions ordinarily encountered in the field. Care must be observed to keep packings from becoming broken or damaged. All broken packings must be repaired immediately and careful attention given to the transfer of all markings to the new parts. This ammunition is packed in a fiber board box, placed in a barrier bag and then placed in wooden boxes. If the barrier bag is punctured or the seal broken in any way, the barrier bag will be replaced and the air evacuated before the new barrier bag is sealed.

b. When it is necessary to leave ammunition in the open, raise it on dunnage at least six inches from the ground and cover it with a double thickness of paulin, leaving enough space for the circulation of air. Where practicable, dunnage strips should be placed under each layer of boxes. Suitable trenches should be dug to prevent water from running under the pile.

c. Since ammunition and explosives are adversely affected by moisture and high temperature, due consideration should be given to 1 and 2 below:

1. Do not open boxes until ammunition is to be used. Ammunition removed from

airtight containers, particularly in damp climates, is apt to corrode, thereby rendering the ammunition unserviceable.

2. Protect ammunition from high temperature and direct rays of the sun. More uniform firing is obtained if rounds are at the same temperature. The combination of high temperature and a humid atmosphere is particularly detrimental to the stability of the propellant powder.
  3. Do not attempt to disassemble the cartridge or any of the components.
  4. The use of oil or grease on cartridges is prohibited.
  5. Ammunition should be protected from sand, mud, moisture, frost, snow, ice, grease, and other foreign matter. If it gets wet or dirty, it should be wiped off at once. If light corrosion forms on the cartridges, it should be wiped off with a clean dry cloth. However, cartridges should not be polished to make them look better or brighter.
  6. Aluminum cartridge cases and ogives are easily dented and should be protected from hard knocks and blows. Dented cartridge cases may cause incomplete obturation, jamming in the chamber, and difficulty in extraction. Damaged ogives may cause erratic flight and permit moisture leakage.
  7. Ammunition, when stored, should be segregated by caliber, type, and ammunition lot number.
  8. When only a part of a box of ammunition is used, the ammunition remaining in the box should be protected against unauthorized handling and use by firmly fastening the cover of the box in place.
- d. When handling this ammunition the precautions contained in TM 9-1900, FM 9-5, and TM 9-1300-206 should be observed.

5-26. AUTHORIZED ROUNDS. The ammunition authorized for use in the grenade launcher XM148 is listed in table 5-3.

TABLE 5-3. AUTHORIZED ROUNDS

Nomenclature	Complete length (inches)	Round weight (ounces)	Projectile	
			Length (inches)	Weight (ounces)
CARTRIDGE, 40-MM: HE, M406 and M381	3.9	8	3.1	6
CARTRIDGE, 40-MM: Practice, M382, M407, and M407A1	3.9	8	3.1	6

5-27. PREPARATION FOR FIRING. After removal from packing materials, cartridges are ready for firing as issued. Cartridges prepared for firing, but not fired, will be returned to their original packing or to suitable packing boxes. The packing boxes should be appropriately marked to indicate the nomenclature of the cartridges, the quantity of the cartridges therein, and the appropriate ammunition lot number. Such cartridges will be used first in subsequent firings, in order that stocks of opened packings may be kept at a minimum.

5-28. PRECAUTIONS IN FIRING. The precautions in a through f below should be closely observed in order to prevent injury to personnel and/or damage to materiel.

a. The cartridges should be free of sand, mud, moisture, frost, snow, ice, grease, or other foreign matter before being fed into the weapon.

b. Ammunition which is seriously corroded should not be fired.

c. Care will be taken at all times to provide adequate protection to the primer and the aluminum ogive since they may be easily dented and should be protected from hard knocks and blows. This is the purpose of the plastic inserts used in the packing of these rounds.

d. Cartridges which have been seriously damaged, or those having an indication of separation, should not be used.

e. During training, targets within an 80 meter radius, from the firer and other personnel, must not be engaged due to fragment hazard when firing high explosive ammunition (M381 and M406). All lots of cartridges, 40-mm practice, M407 and M382 are restricted for use at ranges greater than 200 meters (656 feet). No restrictions exist for cartridge M407A1.

**WARNING**

The HE cartridge M381 and practice cartridge M382 are assembled with the M552 point detonating fuse, which has a minimum of 5 feet arming distance from the weapon. The line of fire should be cleared of all obstruction that might endanger personnel when weapon is fired.

5-29. PACKING.

a. PACKING. The items used for packing and carrying the 40-mm ammunition are shown in figure 5-3 and the packing data is shown in table 5-4.

\* MC I.D. 05538A

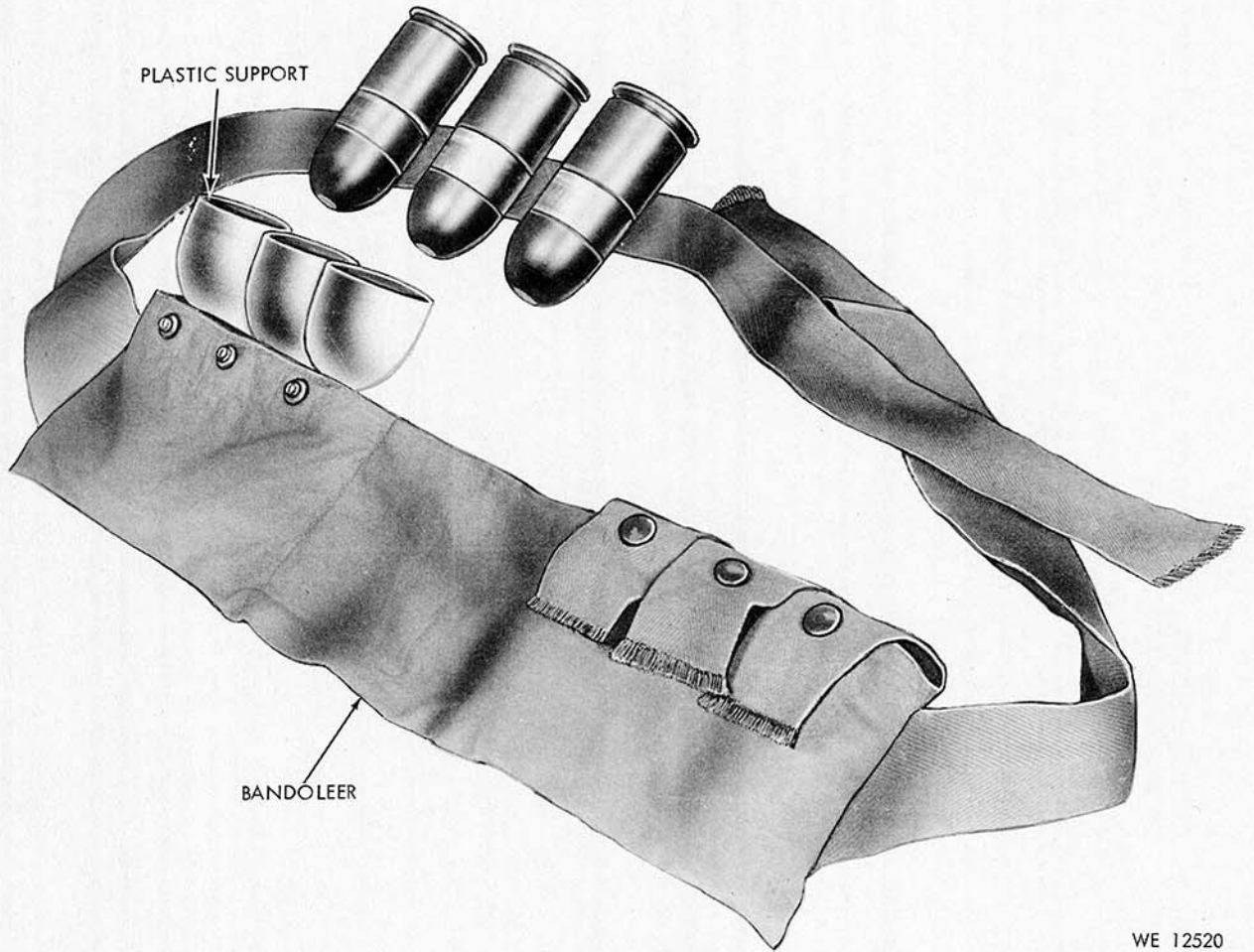

WE 12520

Figure 5-3. Items used for packing and carrying 40-mm ammunition.

TABLE 5-4. PACKING DATA FOR 40-MM AMMUNITION

Packing	Number of Cartridges	Volume (cu ft)	Weight (lb)	Dimensions (in.)
SUPPORT, PLASTIC - contains 3 cartridges	3	-	-	-
BANDOLEER - contains 2 plastic supports	6	-	-	-
BOX, FIBER - contains 12 bandoleers	72	-	-	-
BOX, WOODEN WIREBOUND - contains 1 fiber box	72	1.3	53.0	16-1/4 x 13-1/4 x 10-11/16

## CHAPTER VI DESTRUCTION OF MATERIAL TO PREVENT ENEMY USE

### SECTION I RIFLES

#### 6-1. GENERAL.

6-2. Destruction of the 5.56-mm rifles M16 and XM16E1 when subject to capture or abandonment in the combat zone, will be undertaken by the using arm only when, in the judgement of the unit commander concerned, such action is necessary in accordance with orders of, or policy established by, the Army Commander or Air Force Commander.

6-3. The information which follows is for guidance only. Certain of the procedures outlined require the use of explosives and incendiary grenades which normally may not be authorized items of issue to the using organization. The issue of these and related materials, and the conditions under which destruction will be affected, are command decisions in each case, according to the tactical situation. Of the several means of destructions, those most generally applicable are:

Mechanical ----- Requires axe, pick mattock, sledge, crowbar, or similar implement.

Burning ----- Requires gasoline, oil, incendiary grenades, or other flammables, or welding or cutting torch.

Demolition ----- Requires suitable explosives or ammunition.  
(See note.)

Gunfire ----- Includes artillery, machine guns, rifles using rifle grenades, and launchers using antitank rockets. Under some circumstances hand grenades may be used. (See note.)

Disposal ----- Requires burying in the ground, dumping in streams or marshes, or scattering so widely as to preclude recovery of essential parts.

#### Note

Generally applicable only when the rifle is to be destroyed in conjunction with other equipment.

In general, destruction of essential parts followed by burning will usually be sufficient to render the rifle useless. However, selection of the particular method of destruction requires imagination and resourcefulness in the utilization of the facilities at hand under the existing conditions. Time is usually critical.

6-4. If destruction to prevent enemy use is resorted to, the rifle must be so badly damaged that it cannot be restored to a usable condition in the combat zone either by repair or cannibalization. Adequate destruction requires that all parts essential to the operation of the rifle, including essential spare parts, be destroyed or damaged beyond repair. However, when lack of time and personnel prevents destruction of all parts, priority is given to the destruction of those parts most difficult to replace. Equally important, the same essential parts must be destroyed on all like materiel so that the enemy cannot construct one complete unit from several damaged ones.

6-5. If destruction is directed, due consideration should be given to observance of appropriate safety precautions.

#### 6-6. DESTRUCTION OF THE 5.56-MM RIFLES M16 AND XM16E1.

#### 6-7. METHOD NO. 1 -- BY MECHANICAL MEANS.

6-8. Using an axe, pick mattock, sledge, or other heavy implement, destroy the rifle by smashing the receiver groups, front and rear sights, trigger and trigger guard, magazine, stock, and controls. Also bend the barrel of the rifle and cut the sling into several pieces. Elapsed time: about 3 minutes.

#### 6-9. METHOD NO. 2 -- BY BURNING.

a. Place the rifle on a suitable pile of combustible material. Pour gasoline or oil over the rifle and the combustible material. Ignite and take cover. A hot fire is required to render the rifle useless. Elapsed time: about 3 minutes.

### WARNING

When igniting gasoline, due consideration should be given to the highly flammable nature of gasoline and its vapor. Carelessness in its use may result in painful burns.

b. If a welding or cutting torch is available, burn through the barrel and receiver assembly. Destroy the stock and sling as described in paragraph 6-8 above.

#### 6-10. METHOD NO. 3 -- BY DISPOSAL.

6-11. Bury the rifle in a suitable hole or dump it into a stream. Elapsed time: about 3 minutes.

## SECTION 2 GRENADE LAUNCHER

#### 6-12. GENERAL.

a. Destruction of the grenade launcher XM148 and its ammunition when subject to capture or abandonment in the combat zone will be undertaken by the using army only when, in the judgment of the unit commander concerned, such action is necessary in accordance with orders of or policy established by the Army commander.

b. The information that follows is for guidance only. Certain of the procedures outlined require the use of explosives and incendiary grenades which may not be authorized items for the launcher. The issue of these and related materiel and the conditions under which destruction will be effected are command decisions in each case, according to the tactical situation. Of the several means of destruction, those most generally applicable are:

1. Mechanical - Requires axe, pick mattock, sledge, crowbar, or similar implement.
2. Burning - Requires gasoline, oil, incendiary grenades, or other flammables.
3. Gunfire - Includes artillery, machine guns, and launchers using high-explosive projectiles.
4. Demolition - Requires suitable explosive or ammunition.
5. Disposal - Depends upon the geographical locations, soil conditions, etc., such as loam, clay, sand, swamp, rivers, and other large bodies of water.

In general, destruction of essential parts, followed by burning will usually be sufficient to render the launcher useless. However, selection of the particular method of destruction requires imagination and resourcefulness in the utilization of the facilities at hand under existing conditions. Time is usually critical.

c. If destruction to prevent enemy use is resorted to, the launcher and related materiel must be so badly damaged that they cannot be restored to a usable condition in the combat zone either by repair or cannibalization. Adequate destruction requires that all parts essential to the operation of the launcher or related materiel, including essential parts, be destroyed or damaged beyond repair. However, when lack of time and personnel prevent destruction of all parts, priority is given to the destruction of those parts most difficult to replace. Equally important, the same essential parts must be destroyed and all like materiel so that the enemy cannot construct one complete unit from several damaged ones.

d. If destruction is directed, due consideration should be given to:

1. Selection of a point of destruction that will cause greatest hazard to the enemy, also prevent hazard to friendly troops from fragment or ricocheting projectiles which may occur incidental to destruction.
2. Observance of appropriate safety precautions.

6-13. METHOD NO. 1 - DESTRUCTION BY MECHANICAL MEANS. Using the launcher as a sledge, grasp it by the barrel and swing it against a rock, tree, or some hard object, until barrel breaks away or splits from the launcher housing. Continue to pound housing against the hard object until housing is completely unserviceable. Or, use a sledge, pick, or rock to smash the housing until it is completely useless. Break or bend trigger group, firing pin and pistol grip. Destroy by any means all pins, springs, and attaching hardware. Break rear sight assembly and front sight from sight bar and bend sight bar. Bend barrel or batter until it is kinked or dented.

**WARNING**

Destruction by mechanical means shall not be used on ammunition.

6-14. METHOD NO. 2 - DESTRUCTION BY BURNING.

6-15. GRENADE LAUNCHER XM148. Destruction of essential parts such as the sight and firing mechanism followed by burning in an intense fire will render the launcher useless. Since the launcher is composed almost entirely of metal, sufficient quantities of combustible material should be used to insure a hot fire. However, if combustible material is not available, use incendiary grenades as indicated below.

a. Remove ammunition, if present, from launcher.

b. Place the launcher on the ground.

c. Lay an incendiary grenade on the housing. Fire the grenade.

6-16. AMMUNITION. Lay the ammunition on a pile of combustible material and ignite from a distance by means of a train of flammable material to the pile or toss an incendiary (thermate) grenade onto the pile. Take cover immediately.

**WARNING**

Do not use WP (white phosphorus) grenades when following instructions in paragraphs 6-15 and 6-16. WP grenades burst and throw the burning white phosphorus particles as far as 30 meters (100 feet).

6-17. METHOD NO. 3 - DESTRUCTION BY GUNFIRE. Destroy the launcher by gunfire using artillery, machine guns, rifles using rifle grenades, or launcher using antitank rockets. Fire on the launcher; although one well placed hit may destroy the launcher, several hits may be required for complete destruction.

6-18. METHOD NO. 4 - DESTRUCTION BY EXPLOSIVES.

6-19. GRENADE LAUNCHER XM148.

a. Prepare a 1-pound charge of explosive TNT (using a 1-pound block or equivalent, together with the necessary detonating cord to make up the charge).

b. Place the charge on the housing and tape in place, if possible, or use mud to hold the charge in place.

c. Provide for dual priming to minimize the possibility of a misfire. For priming, either a nonelectric blasting cap crimped to at least 5 feet of safety fuse (safety fuse burns at the rate of 1 foot in 30 to 45 seconds, test before using) or an electric blasting cap and firing wire may be used. Safety fuse which contains black powder and nonelectric blasting caps must be protected from moisture at all times. The safety fuse is ignited by a fuse lighter or a match before taking cover. The electric blasting cap requires a blasting machine or equivalent source of electricity and is fired after taking cover.

**CAUTION**

Keep the blasting caps, detonating cord, and safety fuse separated from the charges until required for use.

d. Detonate the charge. The detonation of the charge will destroy the launcher. If priming with time fuse, ignite and take cover. If primed with electric blasting cap, take cover before firing the charge.

6-20. AMMUNITION. The ammunition can be destroyed in conjunction with the grenade launcher in par. 6-19. It can also be separately destroyed by placing in piles, stacks, or pits and using sufficient amount of demolition explosives (see FM 5-25). Prime and detonate the charges as outlined in c and d above and follow the precaution therein.

6-21. METHOD NO. 5 - DESTRUCTION BY DISPOSAL. There are many ways in which the grenade launcher can be destroyed by disposal. The following methods are recommended:

a. Dig a hole and bury the launcher. Replace and arrange top layer of soil and vegetation to blend with surroundings, so that burial site will be as inconspicuous as possible.

b. If a river, lake, or other body of water is nearby, or in the path of withdrawal, throw the launcher into the water.

c. After partially destroying by mechanical means (Method No. 1), the broken parts and separate components can be disposed of as follows:

1. Bury parts in more than one location.
2. Scatter the parts and components over a wide area.
3. Throw the separate parts into a river, lake, etc.

## CHAPTER VII INSPECTIONS

### SECTION 1 GENERAL

#### 7-1. SCOPE.

7-2. This chapter provides specific instructions for the inspection by maintenance personnel of materiel in the hands of troops in the field, in maintenance shops, and in alerted units scheduled for oversea duty. Trouble shooting information is incorporated wherever applicable as a normal phase of inspection.

#### 7-3. PURPOSE OF INSPECTION.

7-4. Inspections are made for the purpose of (1) determining the condition of an item as to serviceability, (2) recognizing conditions that would cause failure, (3) assuring proper application of maintenance policies at prescribed levels, and (4) determining the ability of a unit to accomplish its maintenance and supply missions.

#### 7-5. CATEGORIES OF INSPECTION.

7-6. In general, three categories of inspection are performed by direct and general maintenance personnel. (Par. 7-7, 7-8 and 7-9).

#### 7-7. INSPECTION OF MATERIEL IN THE HANDS OF TROOPS IN THE FIELD.

a. SPOT-CHECK INSPECTION. This is an inspection performed on a percentage of materiel in order to ascertain the adequacy and effectiveness of organizational maintenance and supply. Included within this scope is inspection of equipment to detect incipient failures before unserviceability occurs; inspection to ascertain the availability and use of technical and supply manuals and lubrication instructions; inspection to determine the accuracy of records, authorized levels of equipment and supplies, practice of supply economy, preservation, and knowledge of the proper procedures for requisitioning supplies and equipment and follow-up thereon.

b. COMMAND MAINTENANCE. (Army) Command maintenance inspections will be performed, at least, annually. The purpose of the

inspection is to ascertain the serviceability of equipment, to predict maintenance and supply requirements, and to determine the adequacy of facilities and effectiveness of procedures. Information obtained during the inspection should indicate future requirements for maintenance and for replacement, as well as disclose immediate needs for maintenance and application of modification work orders. During inspection, correction of deficiencies will be made on the spot when practical. For additional information relative to these inspections and the forms to be used therewith, refer to AR 750-8.

#### 7-8. SHOP INSPECTION.

a. INITIAL INSPECTION. This is an inspection of materiel received in maintenance shops for purpose of determining the degree of repair and parts requirement. This includes determination of modification work orders or TCTO's to be applied.

b. IN-PROCESS INSPECTIONS. These are inspections performed in the process of repairing the materiel, to insure that all parts conform to the prescribed repair standards, that the workmanship is in accordance with approved methods and procedures, and that deficiencies not disclosed by the initial inspection are found and corrected.

c. FINAL INSPECTION. This is an acceptance inspection performed by a final inspector after repairs have been completed, to insure that the materiel is acceptable for return to user or for return to replacement stock according to the standards established.

#### 7-9. PREEMBARKATION INSPECTION.

7-10. This inspection is conducted on materiel in alerted units scheduled for oversea duty to insure that such materiel will not become unserviceable or worn out in a relatively short time. It prescribes a higher percentage of remaining usable life in serviceable materiel to meet a specific need beyond minimum serviceability.

## SECTION 2 INSPECTION PROCEDURES

### 7-11. GENERAL.

#### **WARNING**

Before starting an inspection, be sure to clear the rifle and launcher. Do not actuate the trigger until the rifle and launcher have been cleared. Inspect the chamber to insure that it is empty and check to see that no ammunition is in position to be introduced. Avoid having live ammunition in the vicinity of the work area.

7-12. Check to see that the rifle and launcher have been cleaned of all grease, oil, dirt, or foreign matter which might interfere with proper functioning or obscure the true condition of the parts.

7-13. INSPECTION PRIOR TO DISASSEMBLY.

7-14. VISUAL INSPECTION. Make an overall inspection of the rifle and launcher for general appearance, condition, and operation.

7-15. INITIAL INSPECTION. Initial inspection performed upon receipt of materiel turned in for repair determines the extent of repair required and provides the basis for procuring the parts, assemblies, or supplies necessary to accomplish the repair.

7-16. FUNCTIONAL INSPECTION. Refer to paragraphs 3-29 for rifles and 12-10 through 12-17 for the launcher. Do not use live cartridges.

## CHAPTER VIII REPAIR OPERATIONS

### SECTION 1 TROUBLE SHOOTING

#### 8-1. GENERAL.

8-2. The information contained in this manual is to aid personnel whose responsibility it is to restore worn, damaged, or inoperative equipment to satisfactory condition. This information includes both determination of cause (trouble shooting) and corrective action.

8-3. All repair maintenance shall be done with standard service equipment by all personnel trained in the use of such equipment, using techniques in accordance with procedures in applicable regulations. Personnel using this section of the manual shall have acquired basic skills in trouble shooting, i. e., inspections and analysis of symptoms.

#### 8-4. TROUBLE SHOOTING PROCEDURES.

8-5. USE OF ILLUSTRATIONS. Illustrations in this manual provide information on placement

and identification. Be familiar with normal appearance and placement of the various components and their associated connections.

8-6. INTERNAL AND EXTERNAL TROUBLES. When a malfunction is observed, insure that all operating procedures have been followed exactly as specified, decide if the cause can be identified and the trouble eliminated without dismantling the equipment.

8-7. USE OF THE TROUBLE SHOOTING TABLE. The table of trouble shooting information is designed to aid in locating and correcting malfunctions. Find the trouble that has developed in the first column; then find the cause in the probable cause column. Follow over to the right in the remedy column and take necessary action to correct malfunction.

#### Note

Trouble shooting data for grenade launcher XM148 is listed in chapter XII.

TABLE 8-1. TROUBLE SHOOTING

Malfunction	Probable cause	Remedy
Bolt fails to lock to the rear after the last round.	1. Faulty magazine. 2. Broken bolt catch and/or spring.	Replace magazine. Replace bolt catch and/or spring.
Failure to feed.	1. Faulty magazine. 2. Binding bolt and bolt carrier in locked position.  3. Restricted action spring guide assembly	Replace magazine. Disassemble and clean (On a new weapon, one or two drops of oil on the bolt rings may remedy this trouble).  Remove action spring and action spring guide assembly and clean.
Failure to cycle with selector lever set at automatic.	1. Broken automatic sear or spring. 2. Faulty selector lever. 3. Frozen ejector.	Replace automatic sear assembly. Replace selector lever. Disassemble and clean.

TABLE 8-1. TROUBLE SHOOTING (Continued)

Malfunction	Probable cause	Remedy
Failure to fire.	<ol style="list-style-type: none"> <li>1. Improper assembly of firing pin.</li> <li>2. Broken hammer spring.</li> <li>3. Broken disconnecter or spring.</li> <li>4. Misaligned or worn trigger or hammer spring.</li> <li>5. Improperly installed hammer or trigger spring.</li> </ol>	Reinstall firing pin and check firing pin retaining pin for damage. Replace hammer spring. Replace disconnecter or spring. Replace trigger or hammer spring. Disassemble and install properly.
Fires with selector lever on SAFE.	<ol style="list-style-type: none"> <li>1. Faulty selector lever.</li> <li>2. Faulty or misaligned trigger pin.</li> <li>3. Faulty hammer or trigger.</li> </ol>	Replace selector lever. Replace trigger pin. Replace hammer or trigger.
With selector lever on SEMI, fires when trigger is released.	<ol style="list-style-type: none"> <li>1. Faulty or misaligned trigger pin.</li> <li>2. Faulty hammer or trigger.</li> </ol>	Replace trigger pin. Replace hammer or trigger.
Bolt seizes, will not rotate.	Carbon dirty or burred bolt group.	Hold rifle in vertical position and strike butt <u>sharply</u> on ground, while pulling back on charging handle. <div style="border: 1px dashed black; padding: 2px; text-align: center; width: fit-content; margin: 10px auto;"><b>CAUTION</b></div> Strike butt squarely on ground to prevent breakage of stock. Remove bolt group and clean.
Selector lever binds.	Lack of lubrication.	Apply rifle grease (lubriplate) (Fig. 8-2).

**SECTION 2  
 DISASSEMBLY AND ASSEMBLY**

8-8. GENERAL.

8-9. This section contains instructions on disassembly and assembly.

**Note**

The number in the upper left-hand corner of illustration gives the sequence of disassembly.



The number in the lower right-hand corner of illustration gives the sequence of assembly.



The rifle is composed of three groups: bolt carrier group, lower receiver group, and upper receiver group (figure 3-4). Disassembly and assembly for operator and organizational maintenance is covered in chapter III. Disassembly for higher maintenance levels is shown in figures 8-1, 8-2, and 8-3.

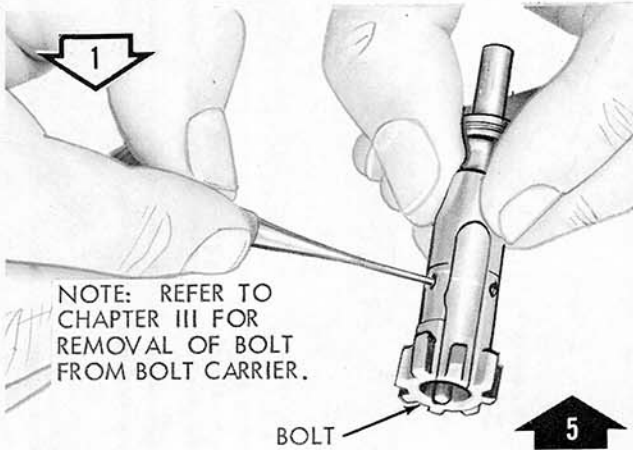

NOTE: REFER TO CHAPTER III FOR REMOVAL OF BOLT FROM BOLT CARRIER.

BOLT

Remove/Install extractor pin.

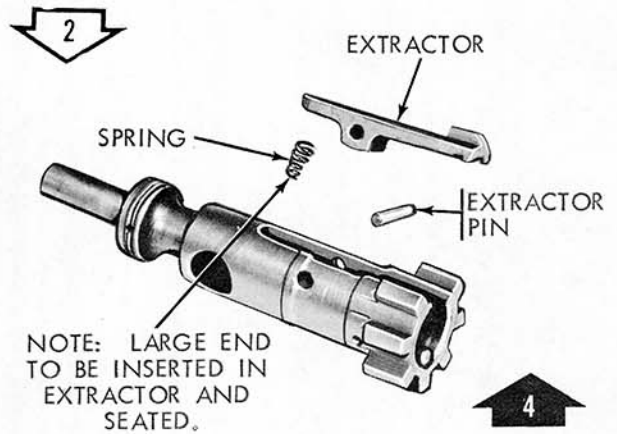

NOTE: LARGE END TO BE INSERTED IN EXTRACTOR AND SEATED.

Remove/Install extractor and extractor spring.

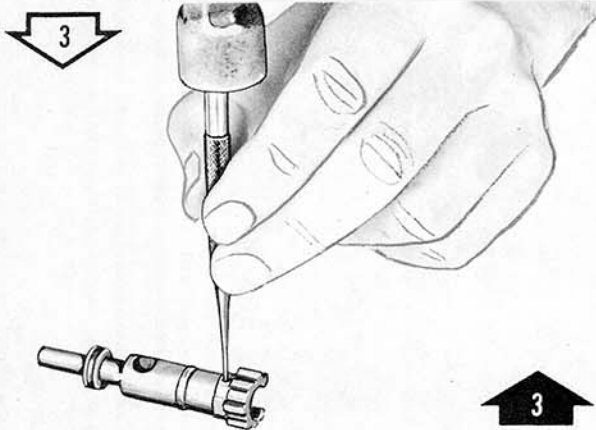

Remove/Install ejector pin.

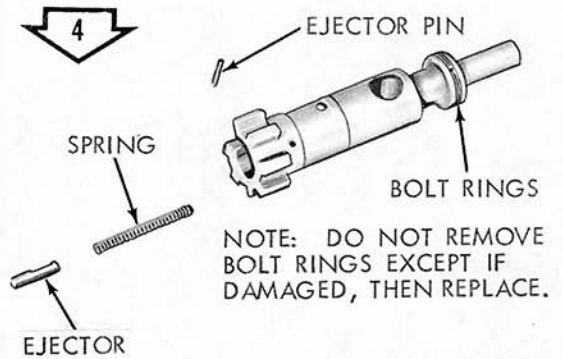

NOTE: DO NOT REMOVE BOLT RINGS EXCEPT IF DAMAGED, THEN REPLACE.

Remove/Install ejector and ejector spring.

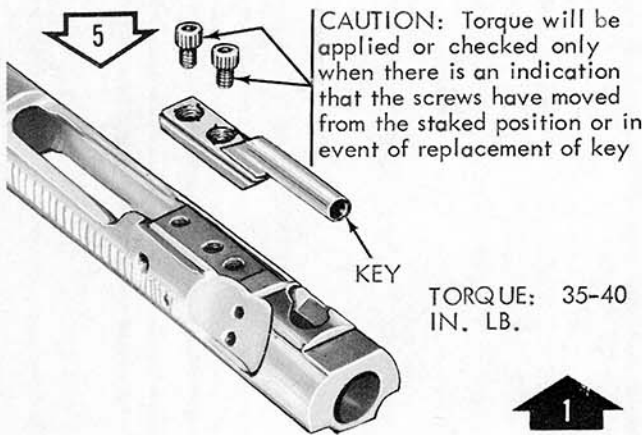

CAUTION: Torque will be applied or checked only when there is an indication that the screws have moved from the staked position or in event of replacement of key

KEY

TORQUE: 35-40 IN. LB.

Remove/Install bolt carrier key.

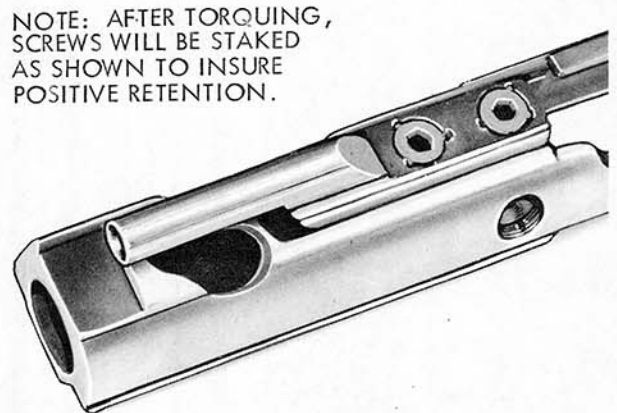

NOTE: AFTER TORQUING, SCREWS WILL BE STAKED AS SHOWN TO INSURE POSITIVE RETENTION.

Screws installed and staked.

Figure 8-1. Disassembly/Assembly of Bolt Assembly and Carrier and Key.

WE 10728

THIS SPACE INTENTIONALLY LEFT BLANK

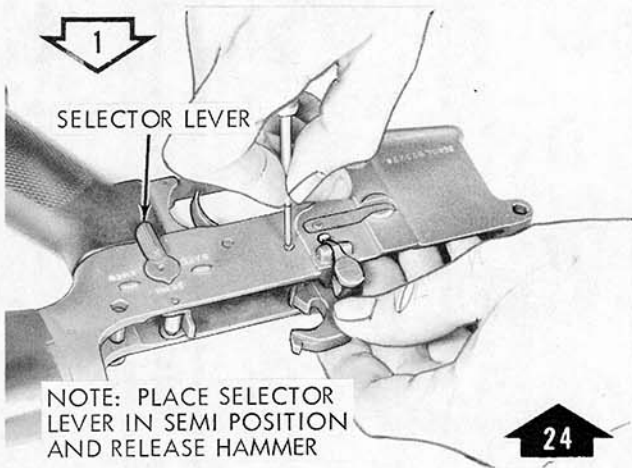

Remove/Install hammer pin.

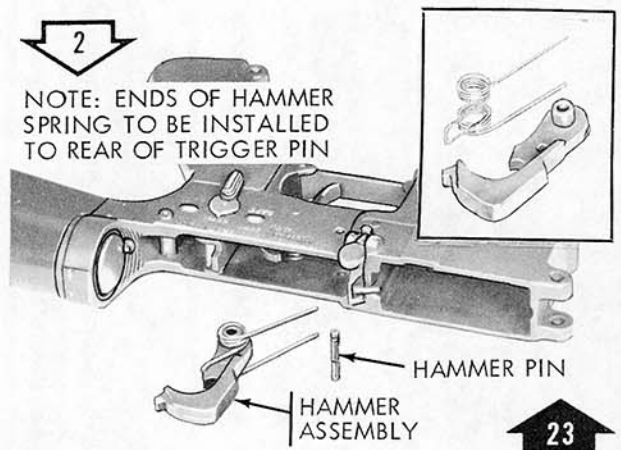

Remove/Install hammer assembly and hammer spring.

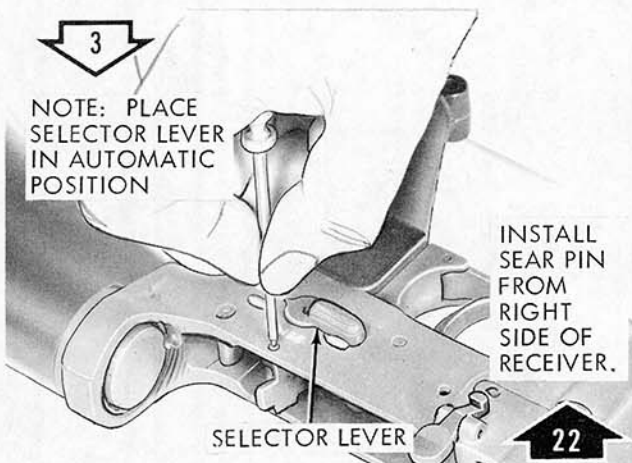

Remove/Install automatic sear pin.

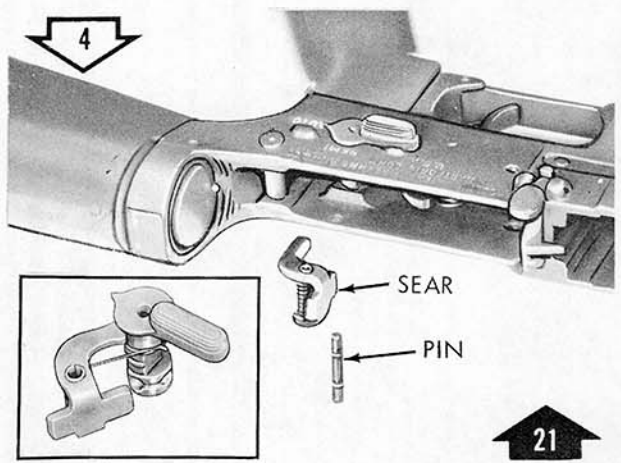

Remove/Install sear.

WE 13624

Figure 8-2. Disassembly/Assembly Lower Receiver Group (Page 1 of 5)

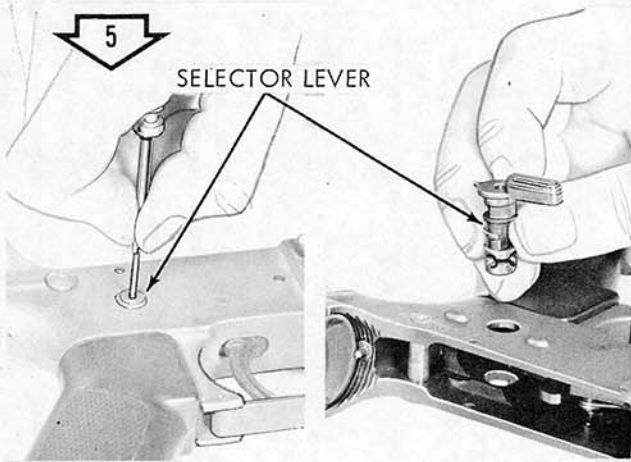

Disengage and remove selector lever.

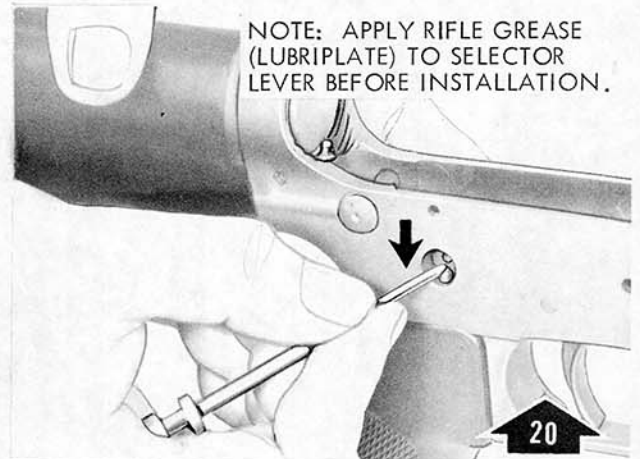

Depress detent - install selector lever.

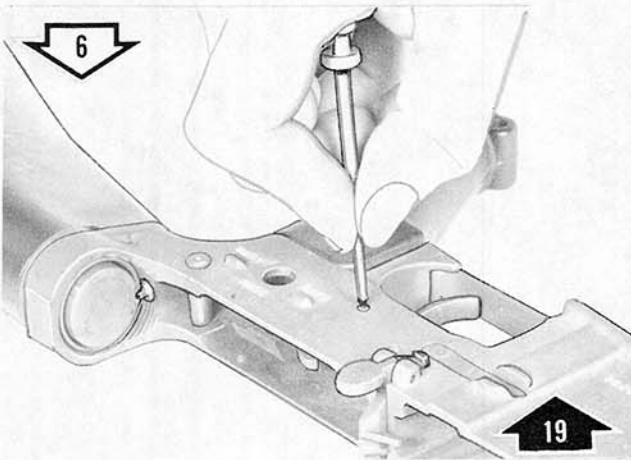

Remove/Install trigger pin.

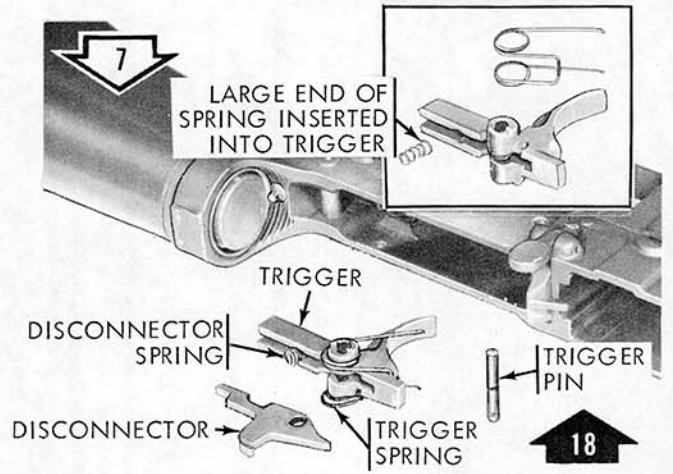

Remove/Install trigger, trigger spring, disconnector, and disconnector spring.

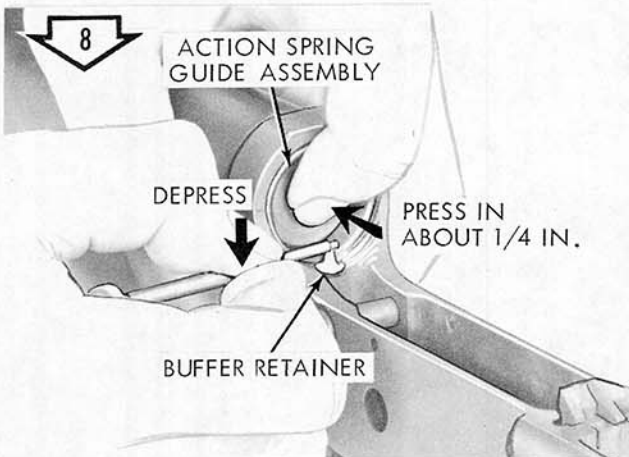

Press in action spring guide assembly, depress buffer retainer, and then release guide assembly.

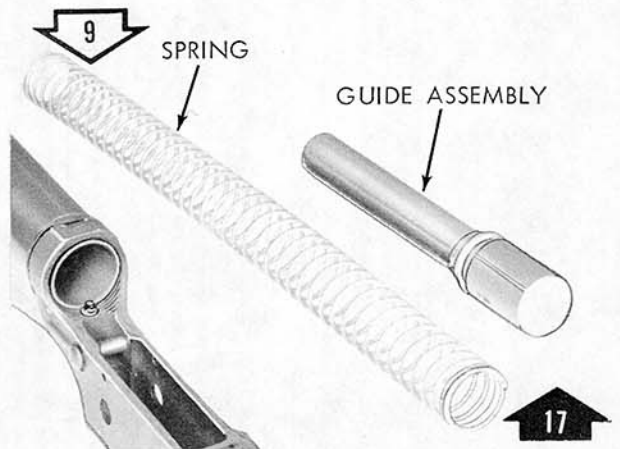

Remove/Install action spring guide assembly and action spring.

WE 13625

Figure 8-2. Disassembly/Assembly Lower Receiver Group (Page 2 of 5)

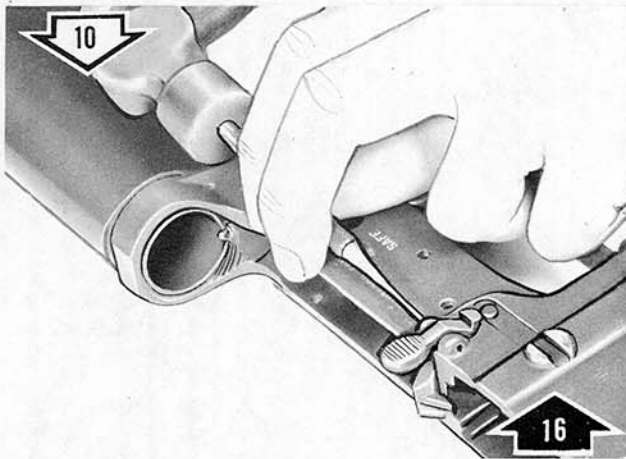

Remove/Install bolt catch spring pin.

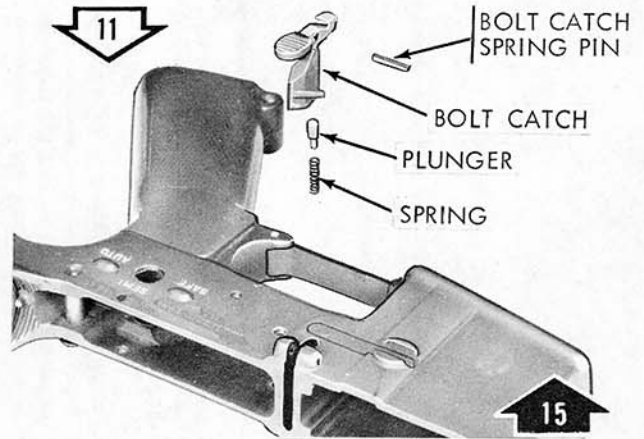

Remove/Install bolt catch, bolt catch plunger, and bolt catch spring.

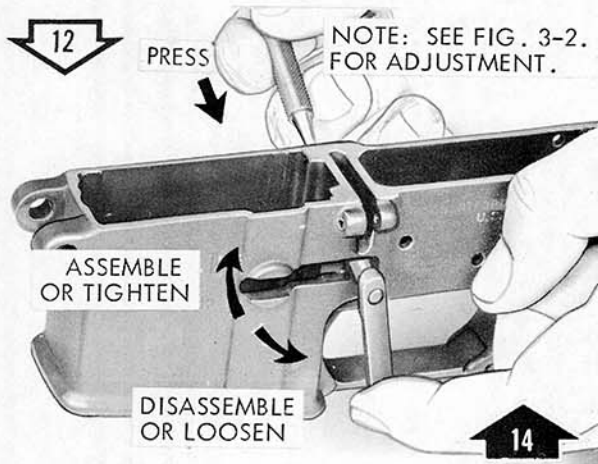

Remove/Install magazine catch.

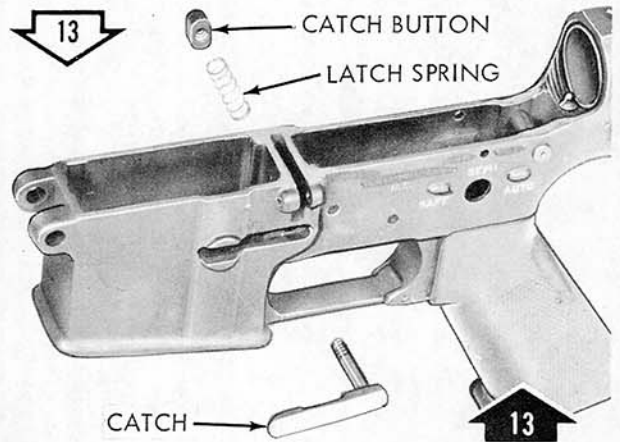

Remove/Install magazine catch button, and magazine catch spring.

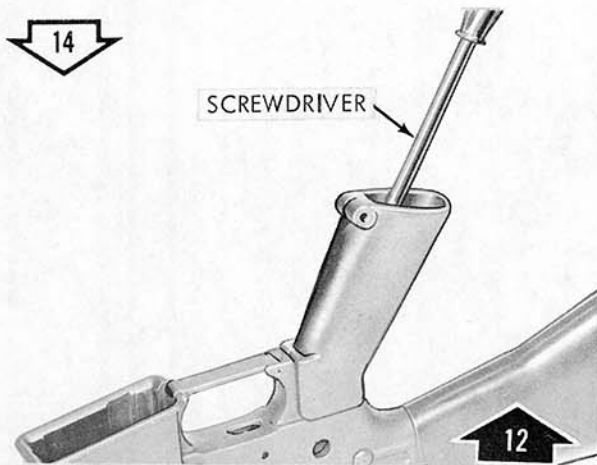

Remove/Install pistol grip machine screw.

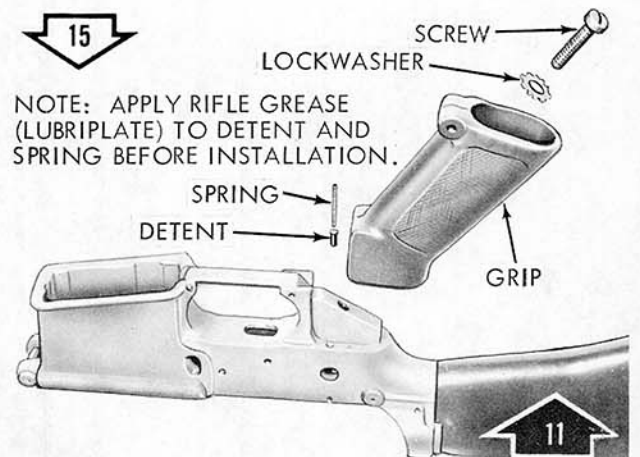

Remove/Install lockwasher, pistol grip, selector lever detent and selector lever detent spring (ejector spring).

WE 13626

Figure 8-2. Disassembly/Assembly Lower Receiver Group (Page 3 of 5)

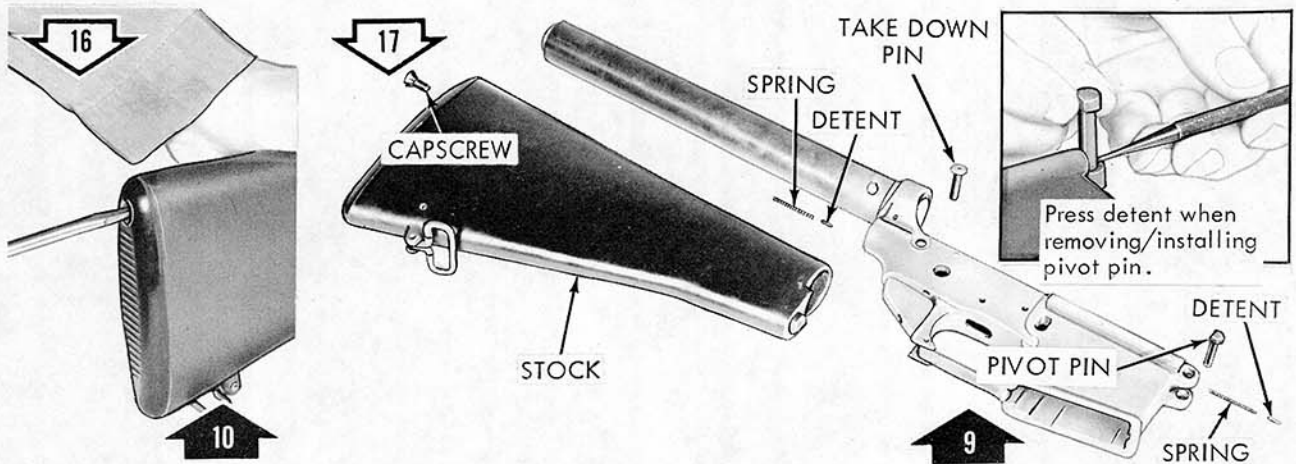

Remove/Install butt cap screw.

Remove/Install stock assembly, springs, detents, take down pin and pivot pin.

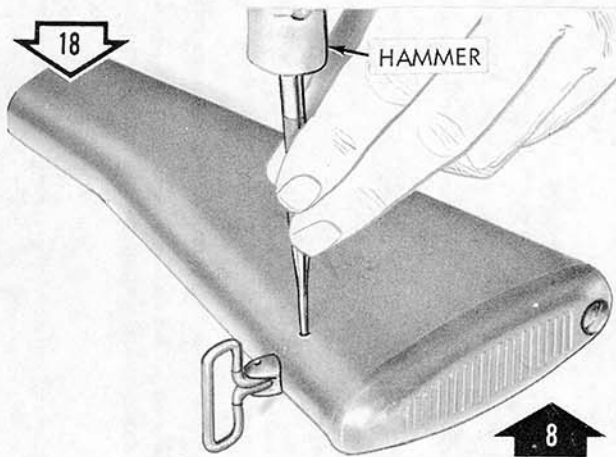

Remove/Install rear swivel spring pin.

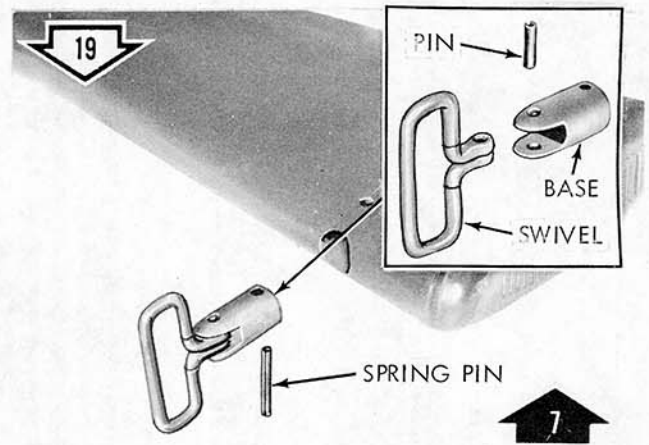

Remove/Install spring pin, gun sling swivel and base.

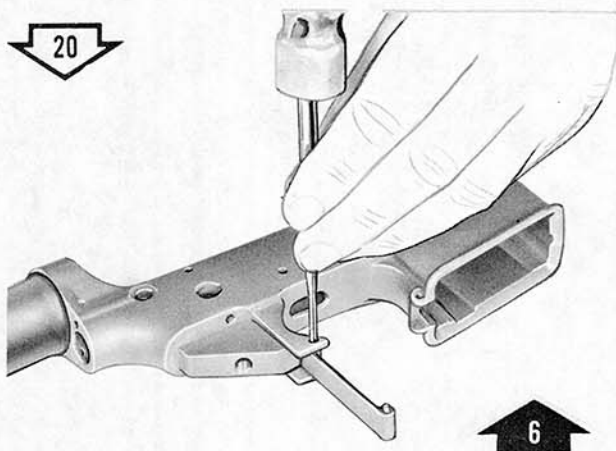

Remove/Install trigger guard spring pin.

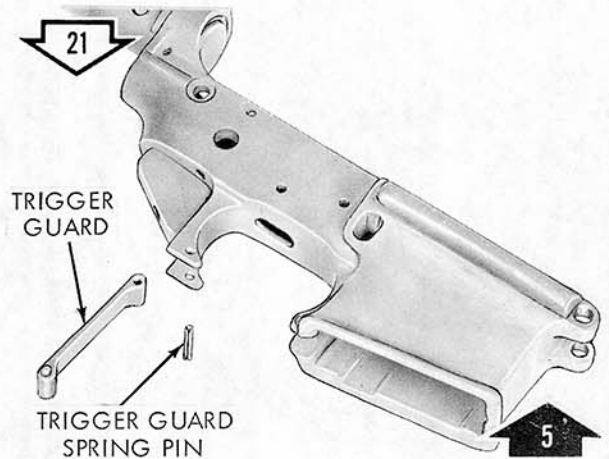

Remove/Install trigger guard.

WE 13627

Figure 8-2. Disassembly/Assembly of Lower Receiver Group (Page 4 of 5)

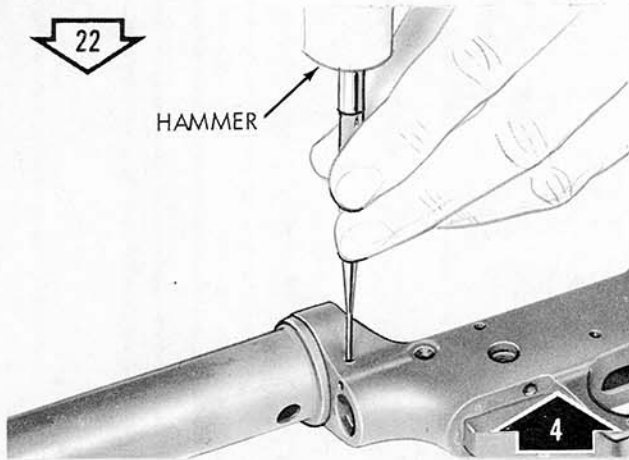

Remove/Install lower receiver extension spring pin.

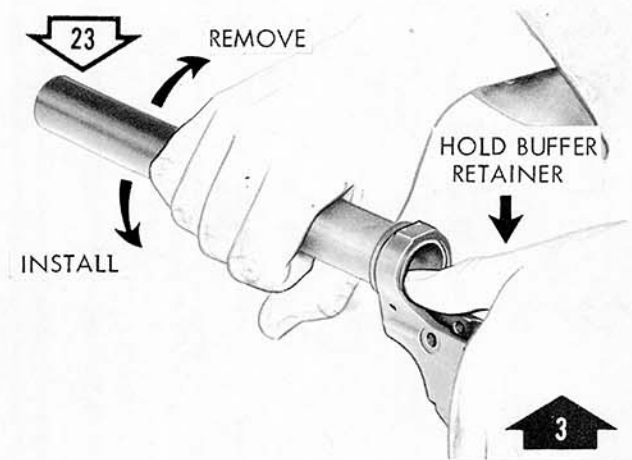

Remove/Install lower receiver extension from/to receiver.

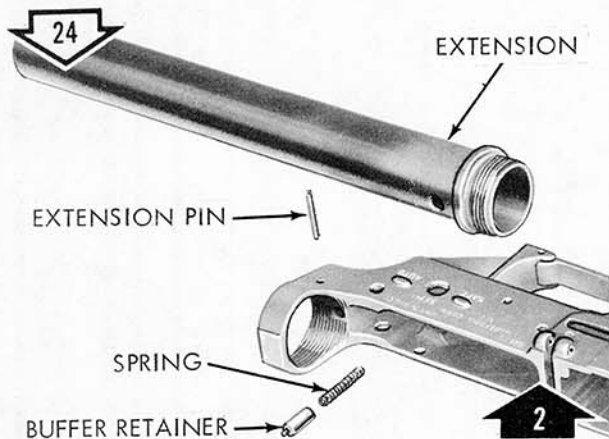

Remove/Install lower receiver extension, buffer retainer and buffer retainer spring from/to receiver.

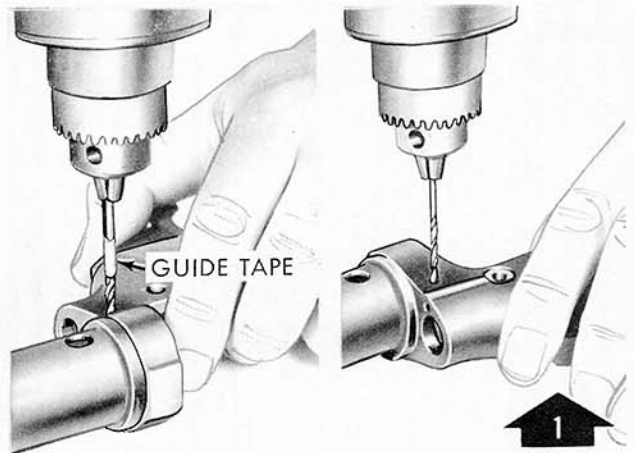

Replacing new receiver extension.

1. Tighten extension securely in receiver.
2. Using receiver as a guide, drill (3/32 drill) approximately 7/16 in. into receiver and extension. (A piece of tape may be put on drill as a guide for the 7/16 in. dimension).
3. Turn over and drill completely through receiver and extension.

WE 13628

Figure 8-2. Disassembly/Assembly Lower Receiver Group (Page 5 of 5)

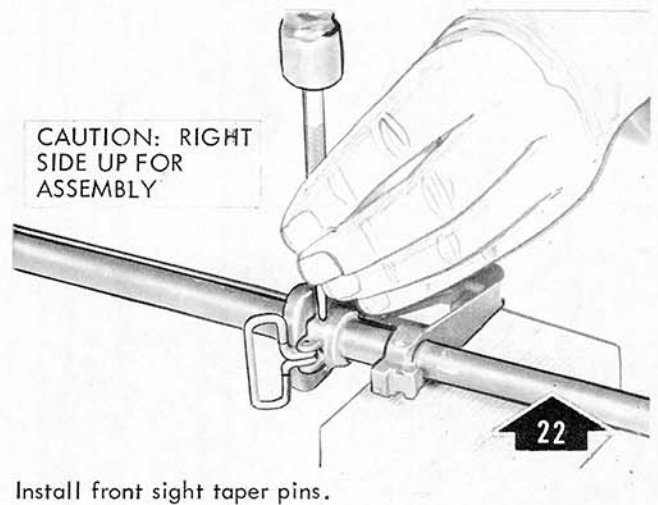
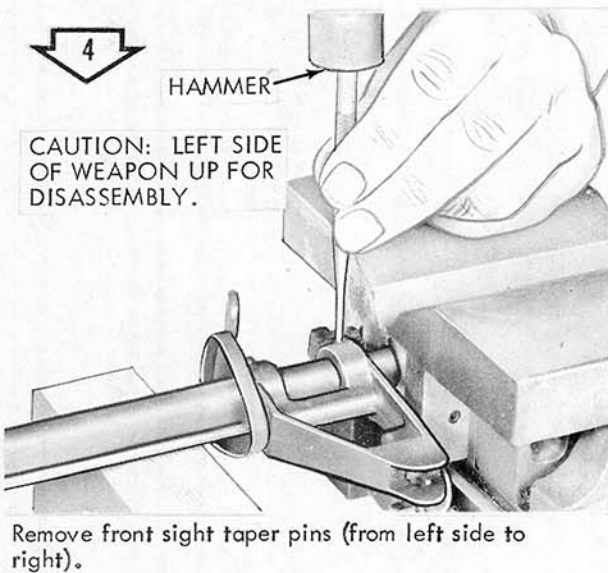
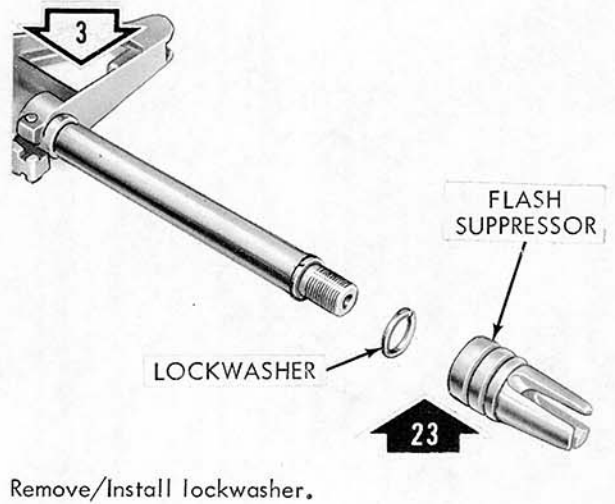
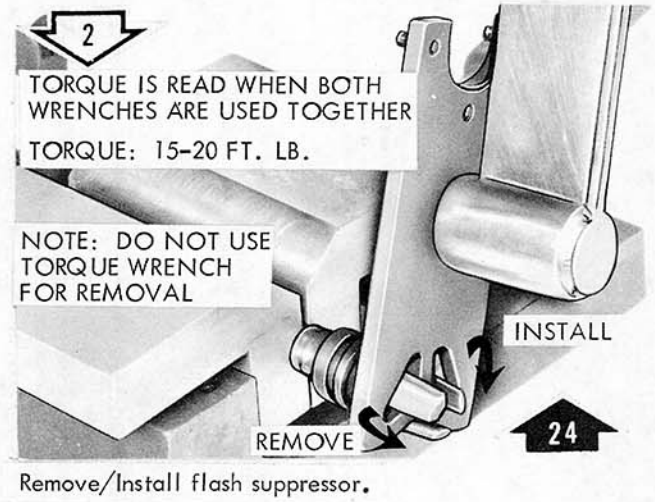
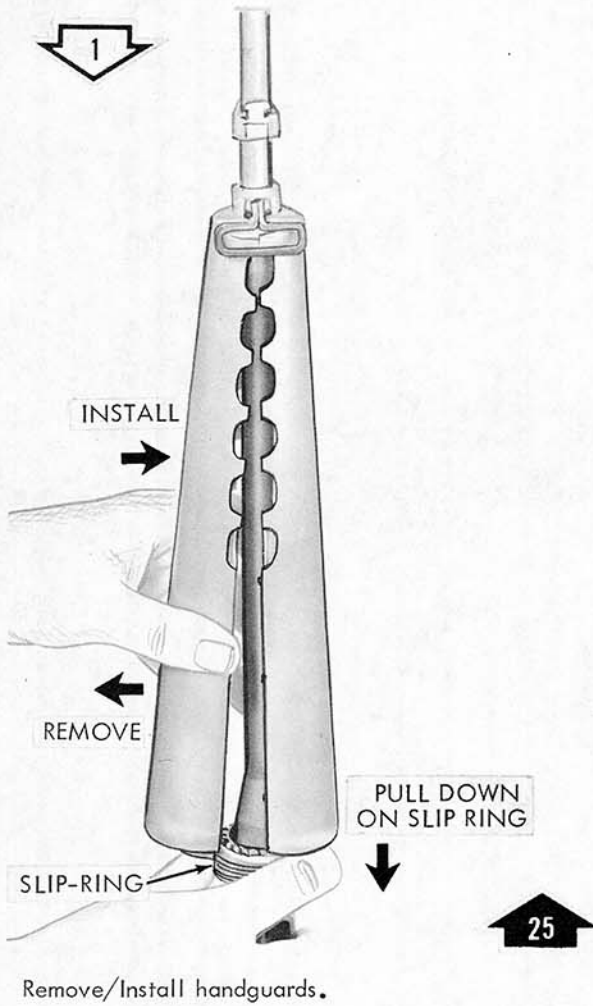

WE 13629

Figure 8-3. Disassembly/Assembly Upper Receiver Group (Page 1 of 6).

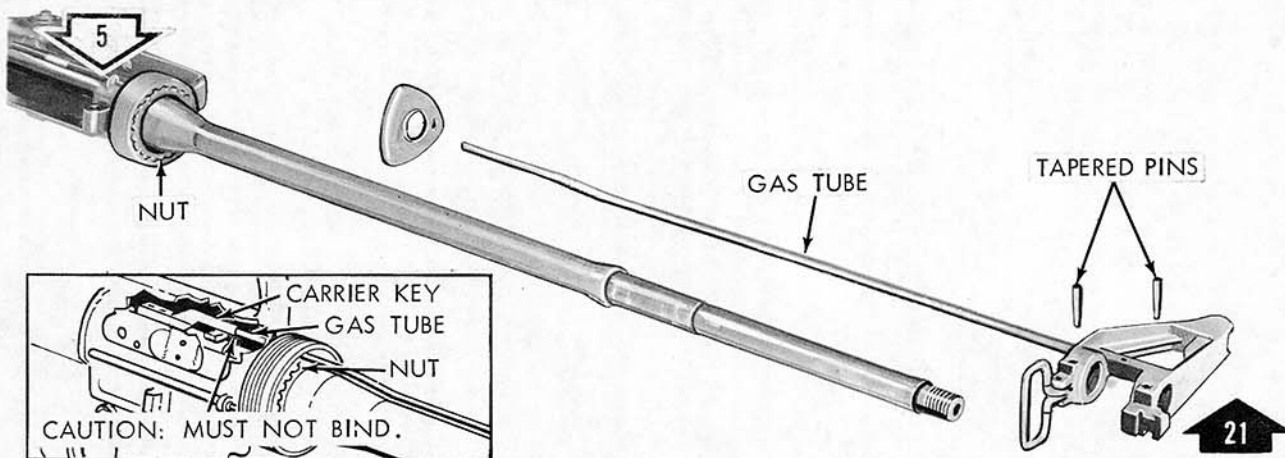

Remove/Install front sight and gas tube.

NOTE: WHEN INSTALLING GAS TUBE, THERE SHALL BE FREE MOVEMENT OF GAS TUBE INTO BOLT CARRIER KEY.

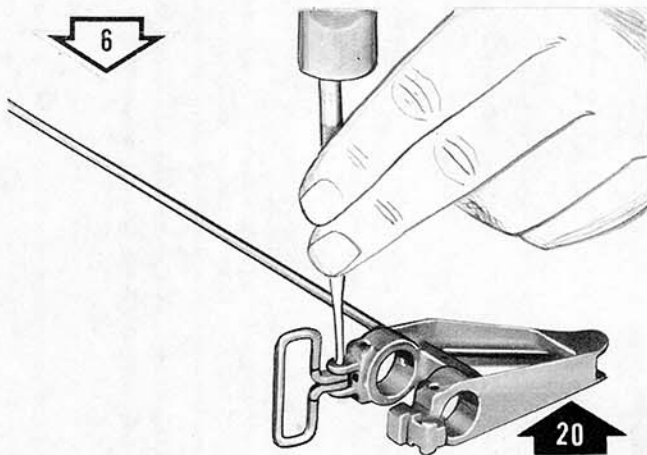

Remove/Install front swivel spring pin.

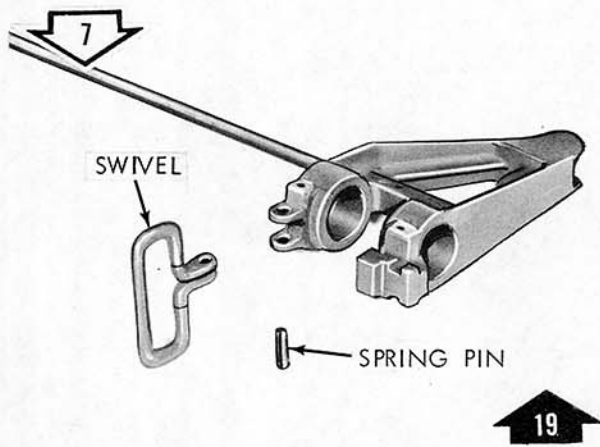

Remove/Install swivel.

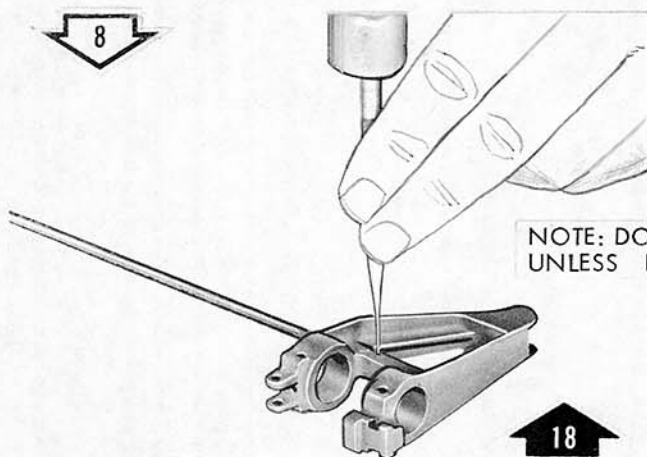

Remove/Install gas tube spring pin.

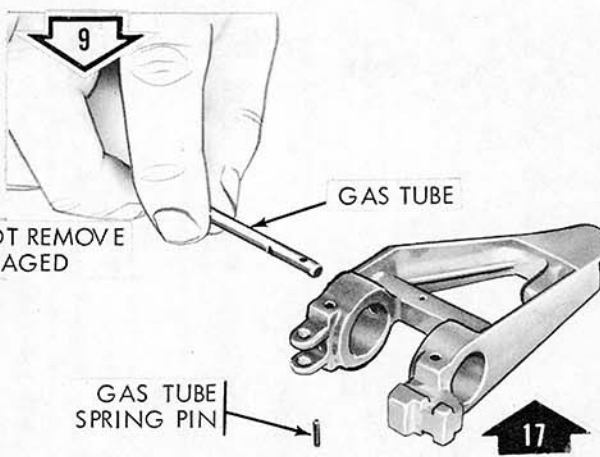

Remove/Install gas tube.

WE 13630

Figure 8-3. Disassembly/Assembly Upper Receiver Group (Page 2 of 6)

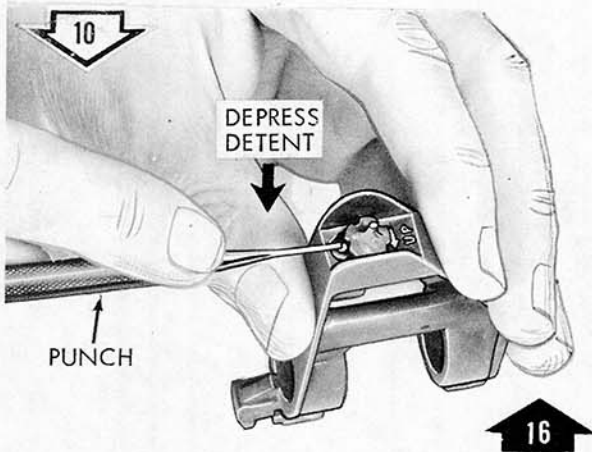

Remove/Install front sight post.

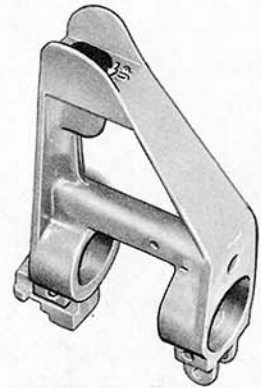
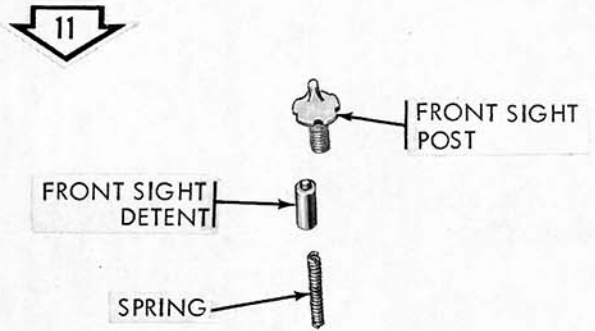

NOTE: APPLY RIFLE GREASE (LUBRIPLATE) TO THREADS ON SIGHT POST, DETENT AND SPRING BEFORE INSTALLATION.

Remove/Install front sight detent and front sight spring.

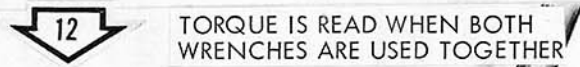

TORQUE: 50 FT. LB THEN TIGHTEN TO ALINE ROD THROUGH NUT

NOTE: DO NOT USE TORQUE WRENCH FOR REMOVAL

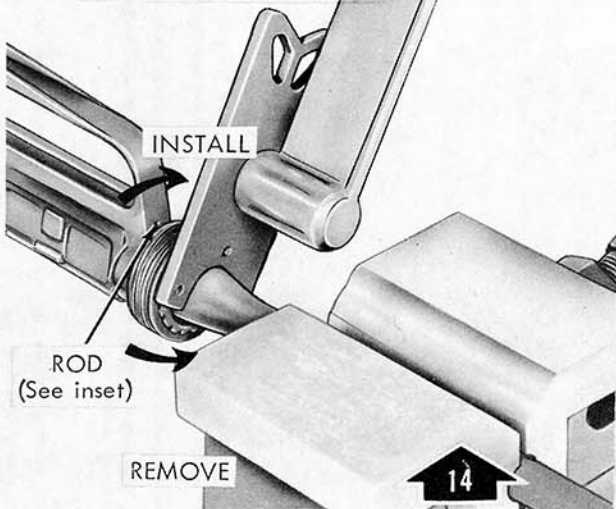
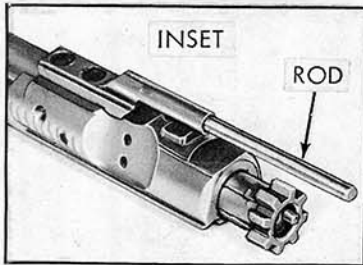

Remove/Install barrel nut assembly.

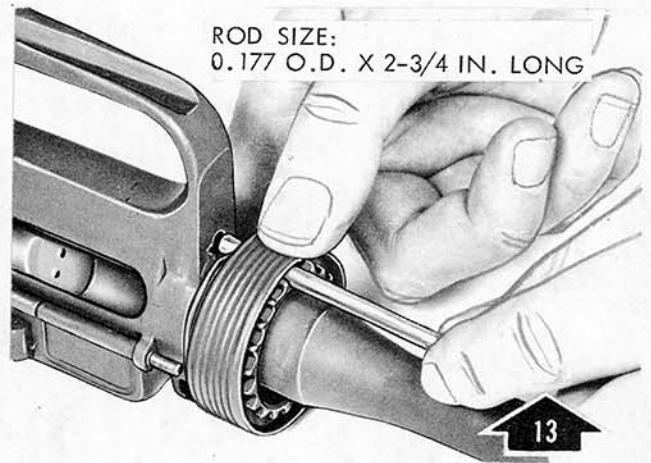

Install and align barrel nut assembly.

Figure 8-3. Disassembly/Assembly Upper Receiver Group (Page 3 of 6).

ORD F9764

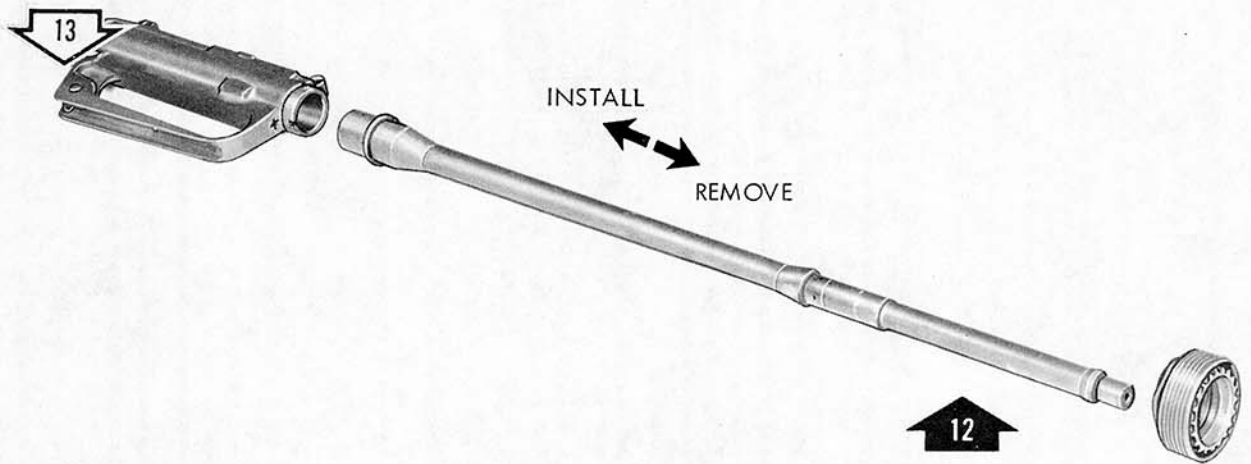

Remove/Install barrel assembly from/to receiver.

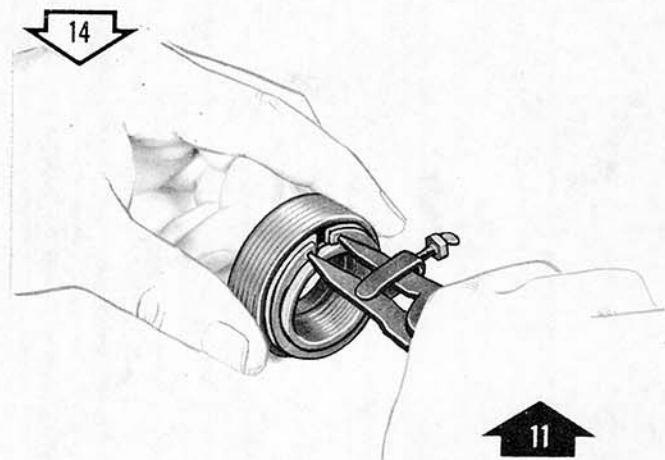

Remove/Install retaining ring.

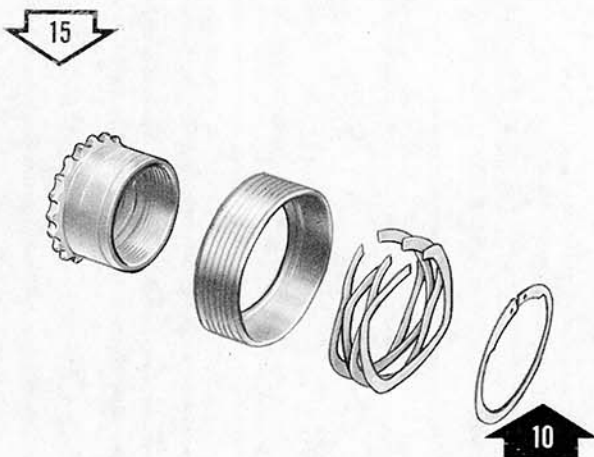

Disassemble/Assemble barrel nut assembly.

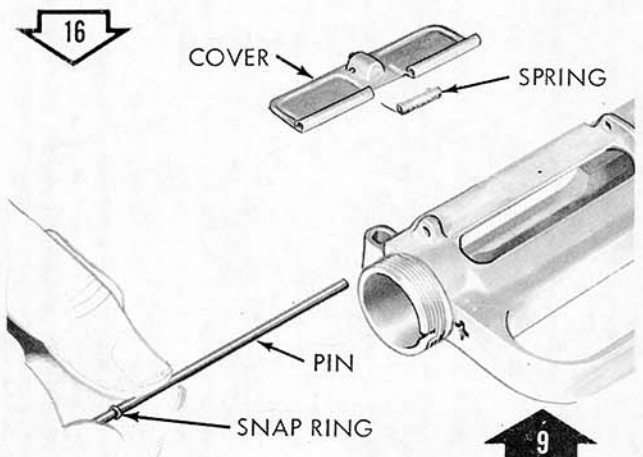

Remove/Install ejector port cover pin, ejector port cover spring and ejector port cover.

WE 13631

Figure 8-3. Disassembly/Assembly Upper Receiver Group (Page 4 of 6)

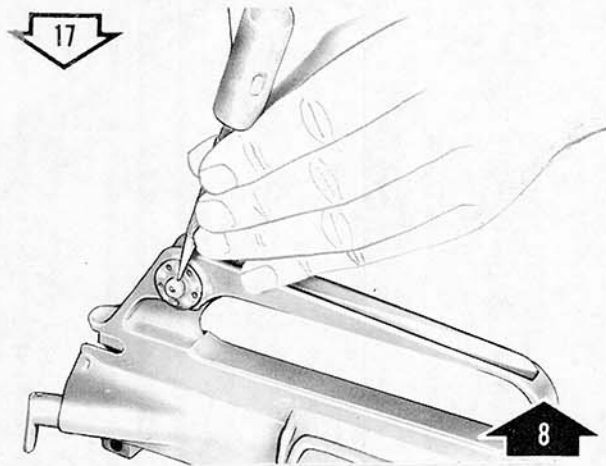

Remove/Install rear sight windage drum spring pin.

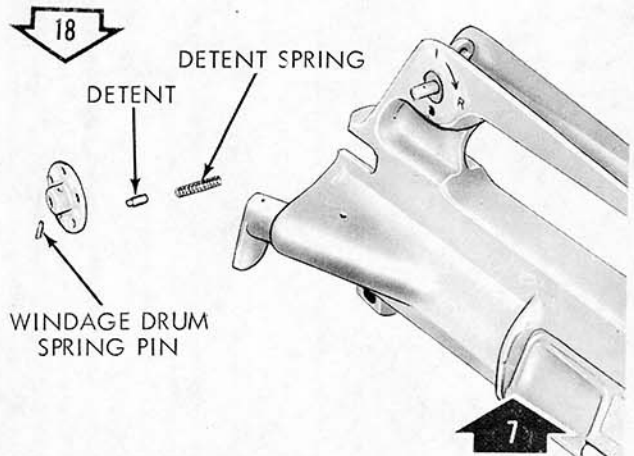

Remove/Install rear sight windage drum, rear sight detent and rear sight detent spring.

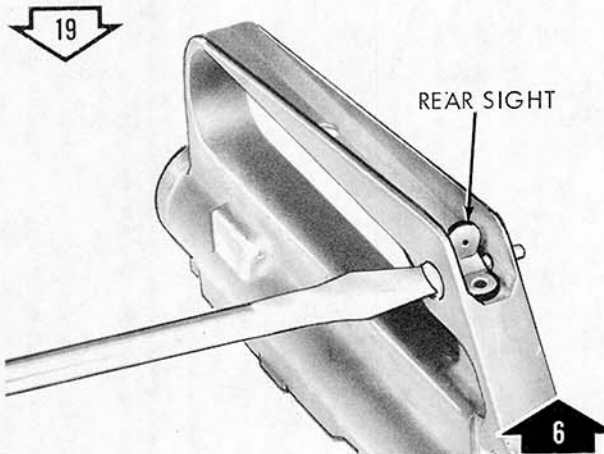

Remove/Install rear sight windage screw.

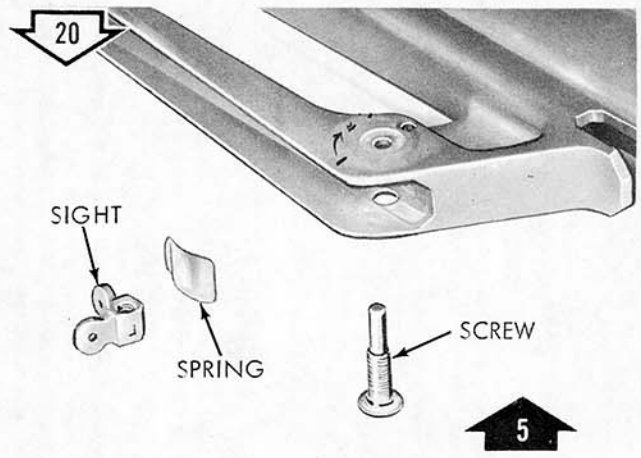

Remove/Install rear sight and rear sight spring.

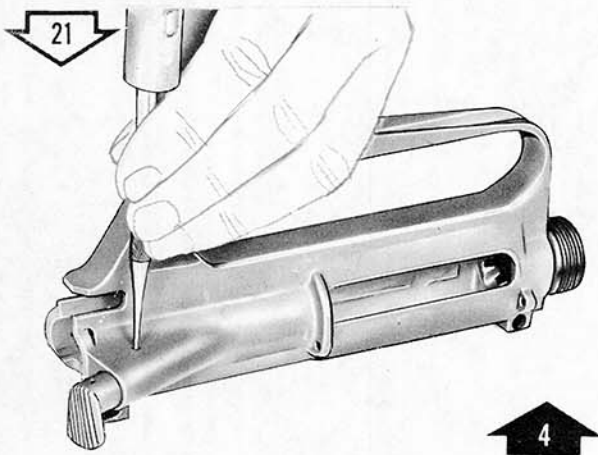

Remove/Install spring pin (XM16E1).

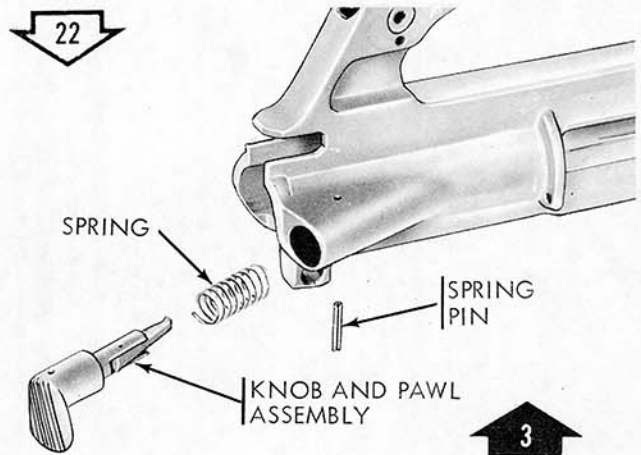

Remove/Install forward assist assembly (XM16E1).

WE 13632

Figure 8-3. Disassembly/Assembly Upper Receiver Group (Page 5 of 6).

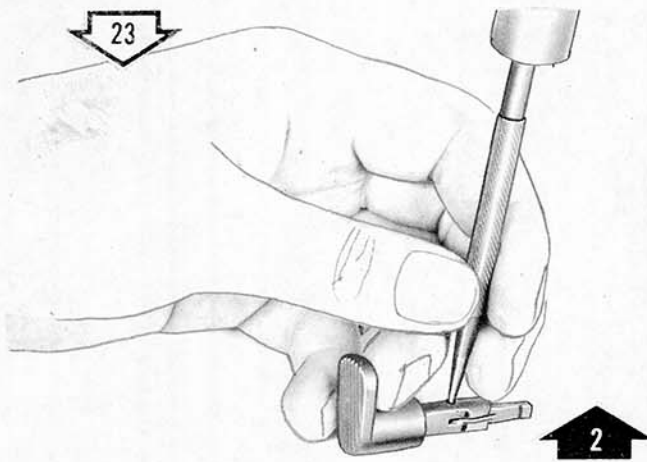

Remove/Install pin (XM16E1).

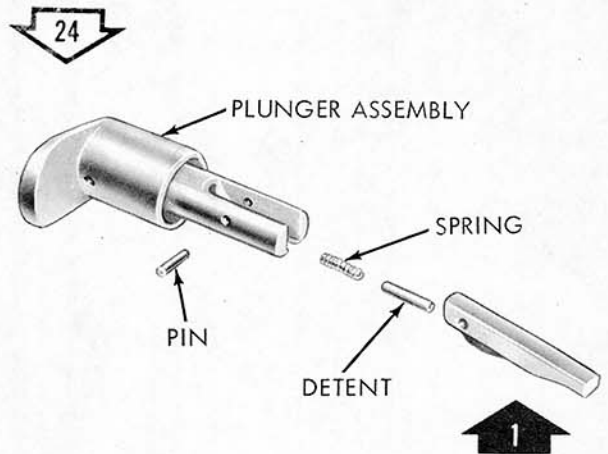

Remove/Install pawl (XM16E1).

ORD F8161

Figure 8-3. Disassembly/Assembly Upper Receiver Group (Page 6 of 6).

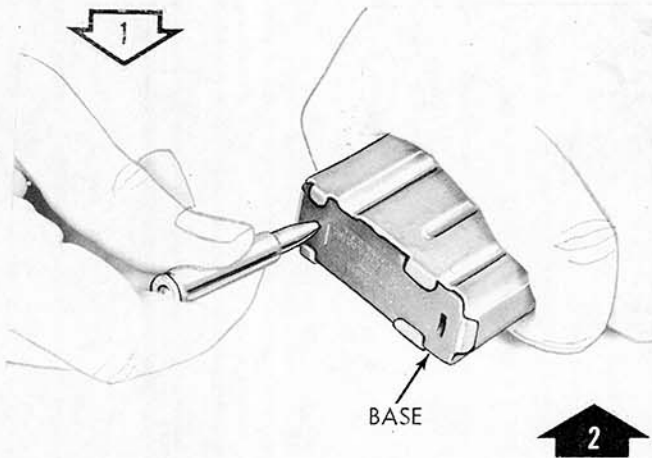

Remove/Install base.

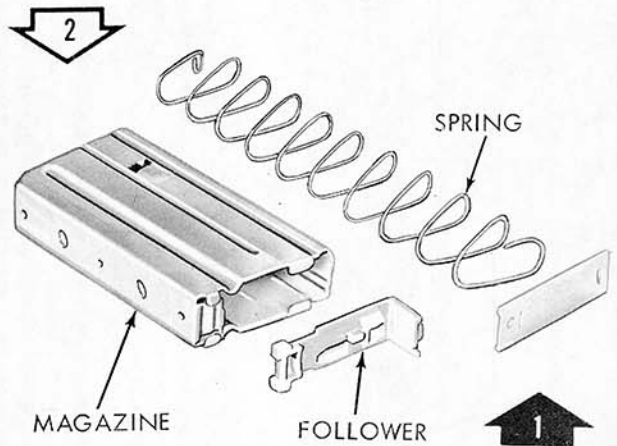

Remove/Install follower.

WE 13633

Figure 8-4. Disassembly/Assembly of Magazine.

THIS SPACE LEFT BLANK INTENTIONALLY

**SECTION 3**  
**CLEANING AND LUBRICATION**

8-10. GENERAL.

8-11. Refer to paragraph 3-25 which supplements this section for cleaning and lubrication.

8-12. Table 8-2 contains procedures for cleaning.

**CAUTION**

Only the cleaning agents in this manual and a vapor degreaser are authorized for cleaning.

TABLE 8-2. CLEANING

Part, Components or Area	Instructions
Barrel extension	Remove carbon and dirt.
Barrel gas port	Remove carbon with a hand-held No. 43 (0.089) drill.
Gas tube	Remove carbon deposits from the tube surface.
Bolt and bolt carrier	Clean extractor recess.  Clean gas relief ports with a hand-held No. 36 (0.106) drill.

**SECTION 4**  
**INSPECTION, TEST, AND ADJUSTMENT**

8-13. INSPECTION.

8-14. Table 8-3 contains procedures for inspection.

TABLE 8-3 INSPECTION

Part, Components or Area	Instructions
Barrel and barrel extension	Inspect surfaces for cracks or defects. Check barrel extension for burrs, broken or worn locking lugs. Inspect bore for damage. Inspect for barrel erosion (figure 8-5).
Front sight and gas tube	Check front sight for cracks and general condition. Check gas tube for cracks.
Upper and lower receiver groups	Inspect the receivers and all parts for cracks. Inspect all parts for wear or damage. Check springs for condition, straightness and tension.
Bolt and bolt carrier	Check for cracks in bolt. Inspect bolt for condition of locking lugs, pitted or chipped bolt face, and elongated firing pin hole. Inspect for broken bolt rings and proper spacing of bolt ring gaps. Ring gaps are not to be in line. Inspect firing pin for wear and burrs. Insert the firing pin into the bolt and with tool 7799735 check firing pin protrusion beyond the bolt face; should be between 0.028 and 0.036 (figure 8-6). Inspect bolt carrier for cracks, burrs and chips. Check socket head cap screws for being staked.

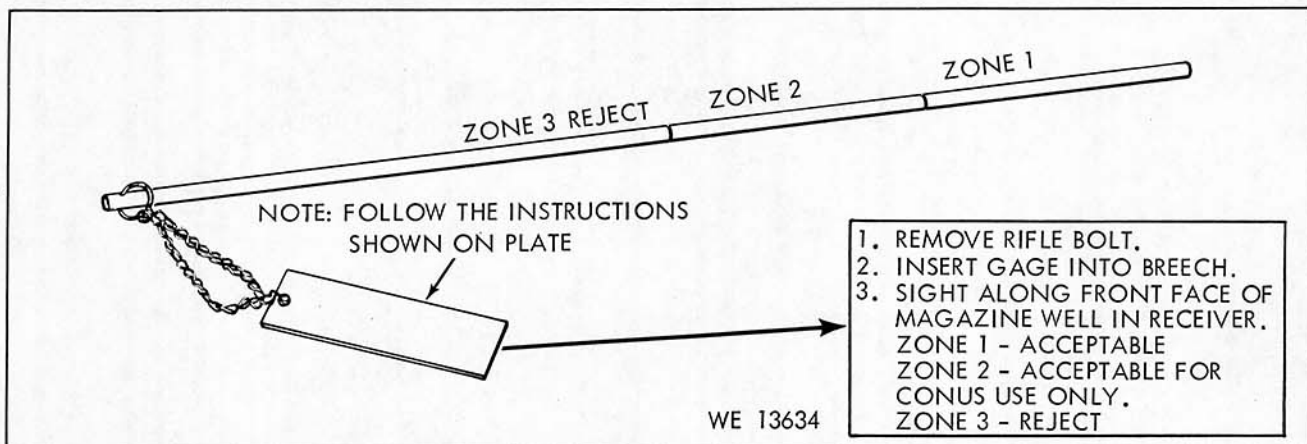

Figure 8-5. Checking Barrel Erosion

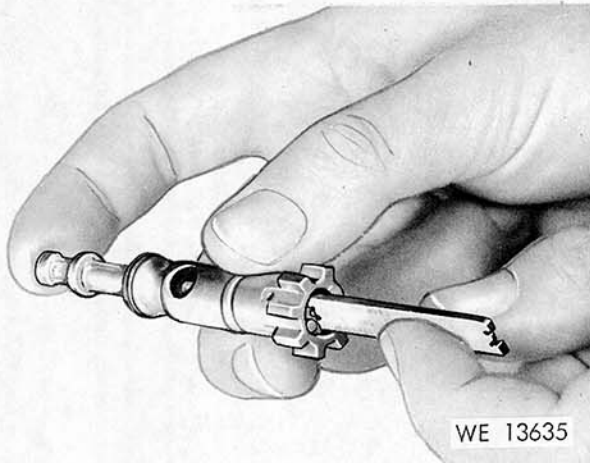

Figure 8-6. Checking Bolt with Firing Pin Protrusion Gage - 7799735

8-15. REPLACEMENT OF PARTS.

8-16. All replacement parts are interchangeable and require no adjustments when being installed in this rifle. However, to insure proper function and full reliability, the following precautions should be taken:

a. Do not interchange bolts and bolt carriers. Keep a bolt with its original bolt carrier.

b. If replacement of either part becomes necessary, carefully check the new part to see that it fits properly, operates smoothly and that proper headspace is provided (figure 8-7).

8-17. TEST.

8-18. The testing of the rifle will consist of:

- a. Checking headspace (figure 8-7).
- b. Function check (paragraph 3-29).

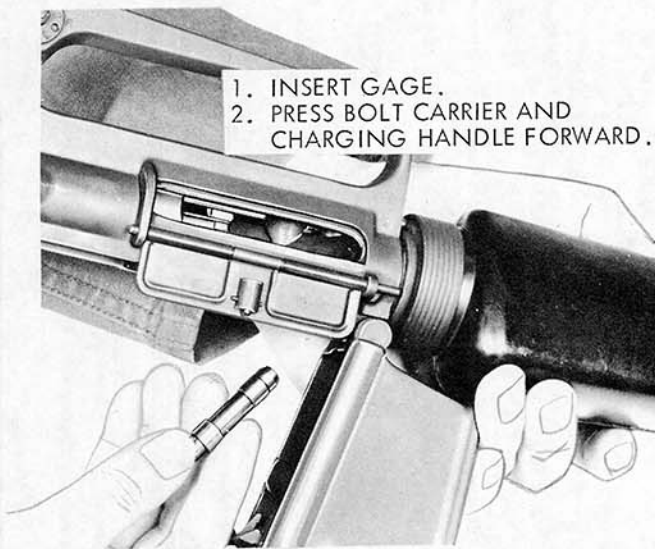

1. Inserting headspace gage.

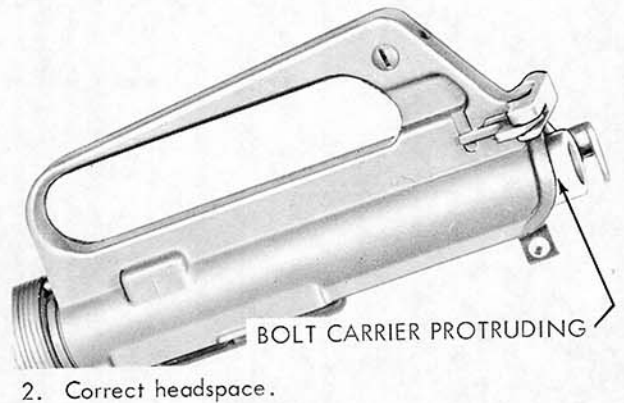

2. Correct headspace.

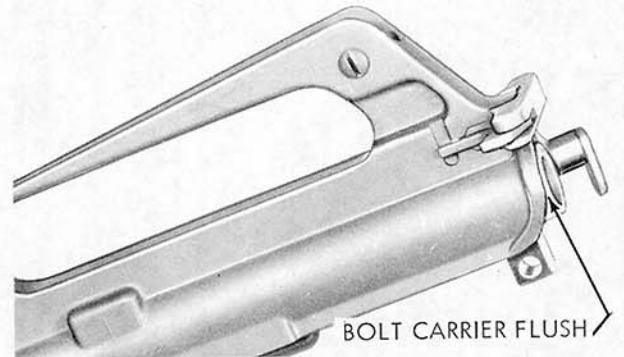

3. Incorrect headspace.

WE 13636

Figure 8-7. Checking Headspace with Headspace Gage - 7799734

## CHAPTER IX

### BASIC ISSUE ITEMS, TOOLS, AND REPLACEMENT PARTS

#### 9-1. GENERAL.

9-2. This chapter lists the basic issue items, tools, equipment and replacement parts for Rifles, 5.56-mm M16 and XM16E1 and Grenade Launcher, 40-mm, XM148.

#### 9-3. EXPLANATION OF COLUMNS.

9-4. GENERAL. The group listings are a breakdown of the equipment by physical description which is supported by illustrations.

#### 9-5. FIGURE AND INDEX. (Column (1)).

a. The figure and index numbers are arranged numerically in the Group Assembly Parts List. The primary use of figure and index numbers is to aid in locating a part in the Group Assembly Parts List after the part has been located in the Illustration. Parts not illustrated will be marked - NI.

b. If a part number is known, the figure and index numbers are found in the Group Assembly Parts List. The index number will provide the part number and nomenclature in the Group Assembly Parts List.

#### 9-6. SOURCE AND MAINTENANCE CODES.

a. AIR FORCE SOURCE CODE (Column (2) (a)). The explanation of source codes is as follows:

P1 - Identifies parts which may be requisitioned and installed by any maintenance level consistent with the activity's authorized scope of maintenance. This code is applied to parts on which usage is anticipated or known and which service manufacture is considered impractical.

P1D - Identifies parts which may be requisitioned and installed by USAF activities authorized depot-level maintenance only. This code is applied to parts on which usage is anticipated or known and which service manufacture is considered impractical.

P2 - Identifies insurance-type spare parts which can be installed by any USAF activity consistent with the activity's authorized scope of maintenance. This code is applied to such parts as are basically structural items of very limited usage which require special tools, templates, and/or jigs and are very difficult, impractical, or uneconomical to manufacture by USAF activities. These items are not subject to periodic replacement or wearout but may require infrequent replacement as a result of accidents or other unexpected occurrences. Delayed procurement items are included under this code.

A - Identifies items capable of being assembled at any level of maintenance and is applied to assemblies of two or more parts the majority of which are purchased and/or service manufactured.

X - Parts considered impractical for service manufacture. Code X is applied to main structure members or similar parts which, if repaired, would suggest extensive repair. The need for a part or parts coded X should normally result in a recommendation to retire the article from service.

X1 - Identifies parts applicable at any level of maintenance consistent with the activity's authorized scope of maintenance and for which it is more feasible to obtain the next higher assembly; for example, an integral detail part such as a welded segment inseparable from its assembly; a part machined in a matched set; or a part of any assembly which, if required, would suggest extensive reconditioning of such assembly. In some cases, code X1 may be used to indicate an integral detail part of an assembly which has no anticipated usage and as an assembly was source-coded "M" or "M1".

b. AIR FORCE MAINTENANCE REPAIR LEVEL CODE (Column (2) (b)). The explanation of maintenance repair level codes is as follows:

- S - NO REPAIR. Identifies items which are nonreparable and have no reclamation value. When these items fail they will be disposed of at user level as condemned material.
- B - NO REPAIR: RECONDITION. Identifies assemblies or parts that will be reconditioned at the user level by adjusting, cleaning, soldering broken connection, etc. If these items cannot be returned to serviceable condition by such means they will be disposed of at user level as condemned material. No repair parts or tools are specially procured for maintenance of these items.
- F - FIELD LEVEL MAINTENANCE. Identifies items which will be repaired by the field level maintenance activities. Normal servicing will be done by organizational level maintenance. Selected parts, tools, and technical order data are procured and provided to applicable field level maintenance activities for repair of these items. No specialized repair activity (SRA) is established for these items. If the condition of these items is such that they cannot be returned to serviceable condition by the field level maintenance activity with authorized parts and tools, they will be disposed of as condemned material. If repair of "F" coded items cannot be accomplished due to unavailability of authorized parts, tools, or other capability, the applicable SSM/IM will be so advised with request for disposition instructions, "F" coded Hi-Value or critical items regardless of condition, will be turned into supply for disposition instructions from applicable SSM/IM.
- c. ARMY SOURCE CODE (Column (2) (c)). The explanation of source codes is as follows:
- P - Applies to high mortality parts.
- Pl - Applies to low mortality parts.
- A - Requisition components under their individual Federal stock number and assembly.
- XI - Requisition next higher assembly or component.
- X - When this part fails, the end item should be turned in for replacement.
- d. ARMY MAINTENANCE LEVEL (Column (2) (d)). The explanation of maintenance level code is as follows:
- O - Organizational Maintenance
- F - Direct Support
- H - General Support
- R - Items which are economically repairable at direct and general support maintenance activities and are normally furnished by supply on an exchange basis. Gages will be forwarded to gage laboratories in accordance with SB 9-75.
- 9-7. FEDERAL STOCK NUMBER (Column (3)). This column lists the federal stock number which has been assigned by the Cataloging Division, Defense Logistics Service Center.
- 9-8. DESCRIPTION (Column (4)). This column lists the Federal Item Name (shown in capital letters) and any additional description required for supply operations. The manufacturers part number is also included for reference.
- 9-9. UNIT OF ISSUE - DS AND GS SUPPORT (Column (5)). This column lists the package quantity to be requisitioned singly or in multiples by Army or Air Force Direct and General Support units. For requisitioning quantities other than listed refer to AR 725-50 for requisitioning procedures.
- 9-10. QUANTITY INCORPORATED IN UNIT (Column (6)). This column lists the quantity of each listed part incorporated in the major item. When a part is common to two or more functional groups, the quantity shown will be the total quantity for the major item. Subsequent listings of the item will refer back to the first listing of the item.
- 9-11. 15-DAY MAINTENANCE ALLOWANCE PER 100 EQUIPMENTS (COLUMN (7)).
- a. This column lists an allowance factor which is based on the latest mortality data and is the estimated average quantity to provide maintenance and, where applicable, supply support for 100 equipments for a 15-day period under combat conditions. A decimal fraction system is used to express the allowance factors.

b. When an allowance factor is inclosed in parentheses, the item is designated as a "combat essential item of a critical nature" and must be stocked at all times, regardless of demand.

c. Since the allowance factors are based on 100 equipments, it is necessary to compute the exact quantity authorized. This quantity is determined by use of a simple mathematical formula. Resulting fractional values of 0.5 or larger will be rounded to the next higher whole number. Fractional values below 0.5 will be rounded to the next lower whole number.

Example 1: If the number of equipments supported is 30 and the allowance factor for 100 equipments is 1.9, the following formula would be used:

$$\frac{30 \times 1.9}{100} = 0.57$$

Since the resulting figure is larger than 0.5 the support would be authorized a quantity of 2.

Example 2: If the number of equipments supported is 89 and the allowance factor for 100 equipments is 3.4, the following formula would be used:

$$\frac{89 \times 3.4}{100} = 3.026$$

In this instance, the result is rounded to the next lower whole number since the fractional value is less than 0.5 and the support would be authorized a quantity of 3.

d. Additional items not expected to fail during the first year, but which may be required to perform authorized direct and general support maintenance in subsequent years, are listed with no allowance factor shown. These parts are identified by an asterisk (\*) in the allowance columns and are to be requisitioned as required for immediate use only.

e. The quantity determined in accordance with (c) above represents the initial stockage for a 15-day period. Major commanders will prescribe the period of time that will be used to compute stockage for each support.

#### Note

The 15-day level is not applicable to tools for direct and general support maintenance.

#### 9-12. SUPPORT UNITS.

9-13. ORGANIZATIONAL. Organizational maintenance is that maintenance normally authorized for, performed by, and the responsibility of a using organization on equipment in its possession. This maintenance consists of functions and repairs within the capabilities of authorized personnel, skills, tools, and test equipment as prescribed in appropriate Department of the Army TOE's or TD's. Maintenance exceeding the authorized scope of maintenance may be performed when authorized by the next higher maintenance support commanders.

9-14. DIRECT SUPPORT. Direct support maintenance is that maintenance normally authorized and performed by designated maintenance activities in direct support of using organizations. This category of maintenance is limited to the repair of end items or unserviceable assemblies in support of using organizations on a return to user basis.

9-15. GENERAL SUPPORT. General support maintenance is that maintenance authorized and performed by designated TOE and TD organizations in support of the Army supply system. Normally TOE and TD general support maintenance organizations will repair or overhaul materiel to required maintenance standards in a ready to issue condition based upon applicable supported Army area supply requirements.

(1) Figure and Index No.	(2) SOURCE AND MAINT CODES				(3) FEDERAL STOCK NO.	(4) DESCRIPTION	(5) Unit of Issue / DS & GS Support	(6) Quantity Incorporated in Unit	(7) 15 - DAY MAINT ALLOW PER 100 EQUIPMENT		
	USAF		ARMY						(a) Organizational	(b) Direct Support	(c) General Support
	(a) Source	(b) Maintenance Repair Level	(c) Source	(d) Maintenance Level							
					1005-856-6885 1005-073-9421	RIFLE, 5.56-MM: M16 (USAF) (62500) RIFLE, 5.56-MM: XM16E1 W/E (ARMY) (8427000)					

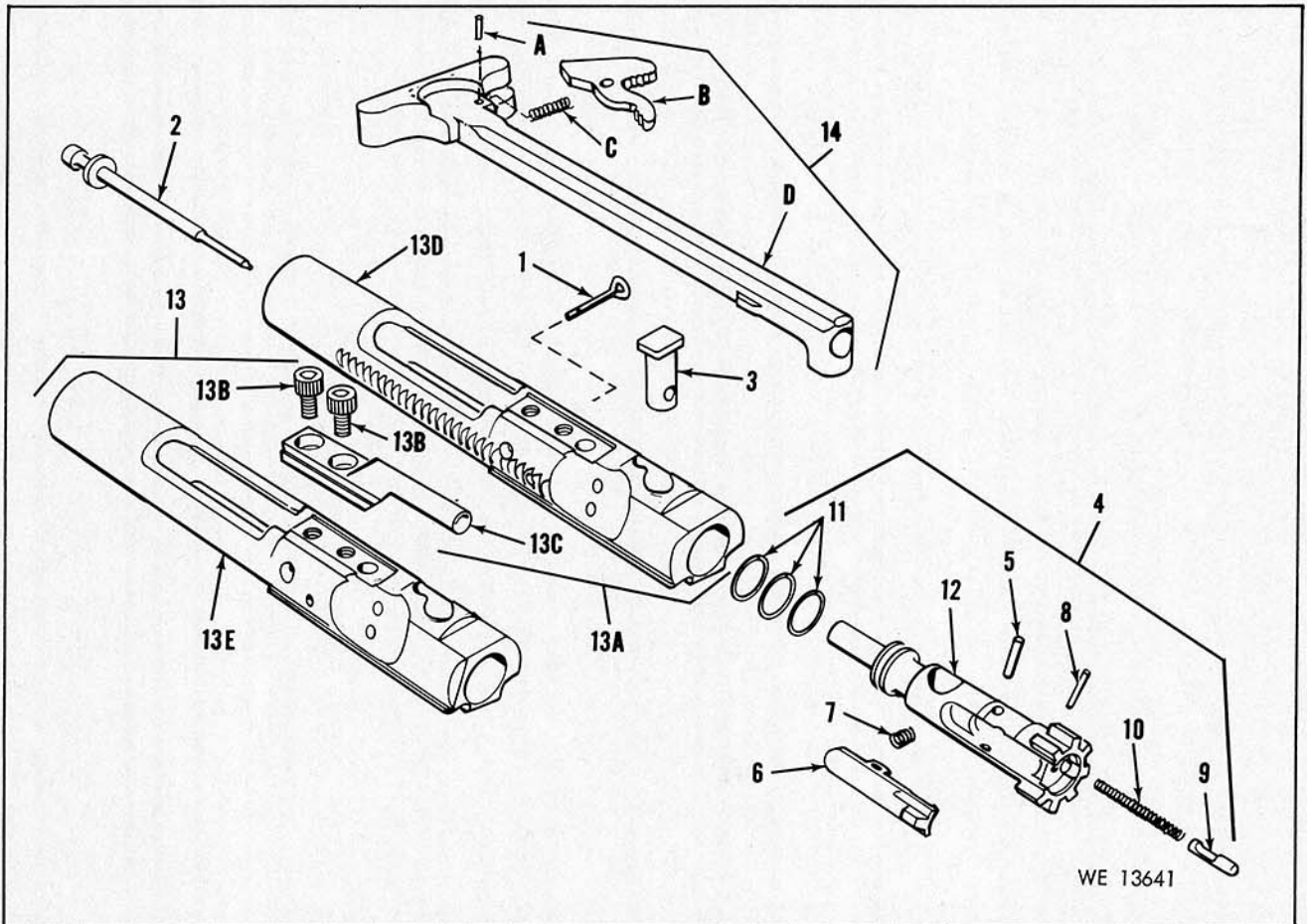
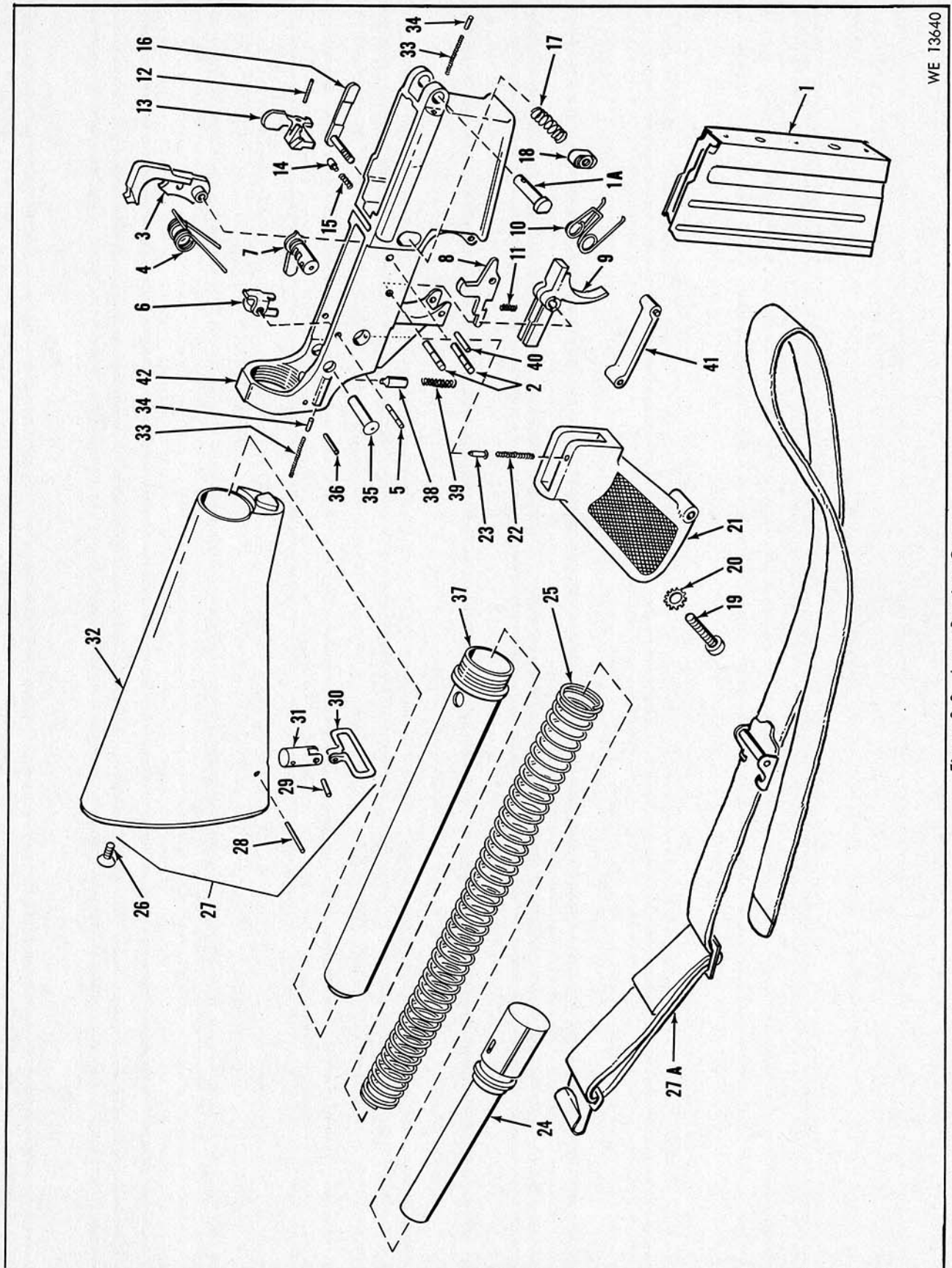

Figure 9-1. Bolt Carrier Group.

(1) Figure and Index	(2) SOURCE AND MAINT CODES				(3) FEDERAL STOCK NO.	(4) DESCRIPTION	(5) Unit of Issue/DS & GS Support	(6) Quantity Incorporated in Unit	(7) 15 - DAY MAINT ALLOW PER 100 EQUIPMENT		
	USAF		ARMY						(a) Organizational	(b) Direct Support	(c) General Support
	(a)	(b)	(c)	(d)							
	Source	Maintenance Repair Level	Source	Maintenance Level							
9-1					BOLT CARRIER GROUP						
9-1-1	P1	B	P1	O	5315-999-1509 . PIN, FIRING PIN RETAINING: (62335)	10	1	(1.0)	(0.8)	(0.2)	
9-1-2	P1	B	P1	O	1005-017-9547 . PIN, FIRING: (62294)	10	1	(1.0)	(0.4)	(0.1)	
9-1-3	P1	B	P1	O	1005-992-7294 . PIN, BOLT CAM: (61704)	1	1	(1.0)	(0.4)	(0.1)	
9-1-4	P1D	F	P1	F	1005-992-7285 . BOLT ASSEMBLY: (62116)	1	1		(0.1)	(0.1)	
9-1-5	P1	B	P1	O	1005-992-7290 . . PIN, EXTRACTOR: (61563)	10	1	(1.0)	(0.4)	(0.1)	
9-1-6	P1	B	P1	O	1005-992-7288 . . EXTRACTOR, SMALL ARM CARTRIDGE: (61562)	1	1	(1.0)	(0.4)	(0.1)	
9-1-7	P1	B	P1	O	1005-992-7289 . . SPRING, EXTRACTOR: (61568)	10	1	(1.0)	(0.4)	(0.1)	
9-1-8	P1	B	P1	O	5315-514-2358 . . PIN, SPRING: tubular, slotted, S, phos-ctd, 1/16 nom dia, 7/16 lg (96906-16562-99)	10	1	(1.0)	(0.4)	(0.1)	
9-1-9	P1	B	P1	O	1005-992-7291 . . EJECTOR, SMALL ARMS CARTRIDGE: (61564)	10	1	(1.0)	(0.2)	(0.1)	
9-1-10	P1	B	P1	O	1005-992-7292 . . SPRING, EJECTOR AND SELECTOR LEVER DETENT: (61569)	10	1	(1.0)	(1.0)	(0.3)	
9-1-11	P1	B	P1	F	1005-992-7287 . . RING, BOLT: (61540)	10	3		(0.4)	(0.1)	
9-1-12	X1	B	X1		. . BOLT: (61538)		1				
9-1-13	A	B			. CARRIER AND KEY: M16 only (61826)		1				
9-1-13	A	B	A		. CARRIER AND KEY: M16 and XM16E1 (62286)		1				
9-1-13	P1	B	P1	F	1005-992-7284 . . . SCREW, CARRIER AND KEY: (92201)	1	2		(0.2)	(0.1)	
9-1-13	P1	B	P1	F	1005-992-7283 . . . KEY, BOLT CARRIER: (61547)	1	1		(0.1)	(0.1)	
9-1-13	P1	F	P1	F	1005-738-6213 . . . CARRIER, BOLT: M16 and XM16E1 (62274)	1	1		(0.1)	(0.1)	
9-1-13	U	F			. . . CARRIER, BOLT: M16 (61544)						
9-1-14	P1	B	P1	O	1005-017-9546 . HANDLE, CHARGING: (62290)	1	1	(1.0)	(0.1)	(0.1)	
9-1-14	P1	B	P1	F	5315-282-3642 . . . PIN, SPRING: tubular slotted, S, phos-ctd, 1/16 nom dia, 1/4 lg (96906-16562-96)	10	3		(0.1)	(0.1)	
9-1-14	P1	B	P1	F	1005-999-0405 . . . LATCH, CHARGING HANDLE: (62289)	1	1		(0.1)	(0.1)	
9-1-14	P1	B	P1	F	1005-999-0404 . . . SPRING, CHARGING, HANDLE LATCH: (61875)	1	1		(0.1)	(0.1)	
9-1-14	X1	B	X1		. . . HANDLE: (62288)	1	1				



WE 13640

Figure 9-2. Lower Receiver Group

(1) Figure and Index No.	(2) SOURCE AND MAINT CODES				(3) FEDERAL STOCK NO.	(4) DESCRIPTION	(5) Unit of Issue /DS & GS Support	(6) Quantity Incorporated in Unit	(7) 15 - DAY MAINT ALLOW PER 100 EQUIPMENT		
	USAF		ARMY						(a) Organizational	(b) Direct Support	(c) General Support
	(a) Source	(b) Maintenance Repair Level	(c) Source	(d) Maintenance Level							
92											
92-1	P1	B			1005-056-2237	• MAGAZINE ASSEMBLY: (62103)	1	1	(2.0)	(4.0)	(2.4)
NI	P1	B			1005-992-6671	• PIN, PIVOT: early M16 (95601)	10	1		(0.2)	(0.1)
92-1 A	P1	B	P1	O	1005-017-9537	• PIN, PIVOT: M16 and XM16E1 (62221)	10	1	(1.0)	(0.2)	(0.1)
92-2	P1	B	P1	F	1005-992-7309	• PIN, HAMMER AND TRIGGER: (61654)	20	2		(0.4)	(0.1)
92-3	P1	B	P1	F	1005-017-9551	• HAMMER ASSEMBLY: lower receiver (62317)	1	1		(0.2)	(0.1)
92-4	P1	B	P1	F	1005-992-6648	• SPRING, HAMMER: (61697)	10	1		(0.2)	(0.1)
92-5	P1	B	P1	F	1005-992-6650	• PIN, AUTOMATIC SEAR: (61615)	10	1		(0.1)	(0.1)
92-6	P1	B	P1	F	1005-992-6649	• SEAR, AUTOMATIC: (61622)	1	1		(0.1)	(0.1)
92-7	P1	B	P1	F	1005-992-6666	• LEVER, SELECTOR: safety and firing (61959)	1	1		(0.1)	(0.1)
92-8	P1	B	P1	F	1005-999-0406	• DISCONNECTOR: (62334)	10	1		(0.1)	(0.1)
92-9	P1	B	P1	F	1005-992-7307	• TRIGGER: (61955)	1	1		(0.1)	(0.1)
92-10	P1	B	P1	F	1005-992-7308	• SPRING, TRIGGER: (61657)	10	1		(0.1)	(0.1)
92-11	P1	B	P1	F	1005-992-7311	• SPRING, DISCONNECTOR: (61925)	10	1		(0.2)	(0.1)
92-12	P1	B	P1	F	5315-812-3312	• PIN, SPRING: tubular, slotted, S, phos-ctd, 3/32 nom dia, 1/2 lg (96906-16562-119)	10	1		(0.1)	(0.1)
92-13	P1	B	P1	F	1005-017-9548	• CATCH, BOLT: (62301)	1	1		(0.1)	(0.1)
92-14	P1	B	P1	F	1005-056-2247	• PLUNGER, BOLT CATCH: (62178)	10	1		(0.1)	(0.1)
92-15	P1	B	P1	F	1005-056-2246	• SPRING, BOLT CATCH: (62177)	10	1		0.2	0.1
92-16	P1	B	P1	F	1005-056-2201	• CATCH, MAGAZINE: (61604)	1	1		(0.1)	(0.1)
92-17	P1	B	P1	F	1005-992-7301	• SPRING, MAGAZINE CATCH: (61759)	10	1		(0.1)	(0.1)
92-18	P1	B	P1	F	1005-992-7302	• BUTTON, MAGAZINE CATCH: (62032)	10	1		(0.1)	(0.1)
92-19	P1	B	P1	O	5305-723-2454	• SCREW, MACHINE: fil-hd, dld-f/lkg-wire, cres, pass-fin., 1/4-28NF-2A, 1-1/8 lg (96906-35276-84)	10	1	(1.0)	(0.1)	(0.1)
92-20	P1	B	P1	O	5310-527-3634	• WASHER, FLAT: external teeth, S, passivated fin., 1/4 nom size, 0.267 max id, 0.510 max od, 0.028 max thick (96906-35335-61)	1	1	(1.0)	(0.1)	(0.1)
92-21	P1	B	P1	O	1005-056-2250	• GRIP, PISTOL: black (62194)	1	1	(1.0)	(0.2)	(0.1)

(1) Figure and Index No.	(2) SOURCE AND MAINT CODES				(3) FEDERAL STOCK NO.	(4) DESCRIPTION	(5) Unit of Issue /DS & GS Support	(6) Quantity Incorporated in Unit	(7) 15 - DAY MAINT ALLOW PER 100 EQUIPMENT		
	USAF		ARMY						(a) Organizational	(b) Direct Support	(c) General Support
	(a) Source	(b) Maintenance Repair Level	(c) Source	(d) Maintenance Repair Level							
9-2-22	P1	B	P1	O	1005-992-7292	. SPRING, EJECTOR AND SELECTOR LEVER DETENT: (61569) See allowance under item 9-1-10	10	1			
9-2-23	P1	B	P1	F	1005-992-6667	. DETENT, SELECTOR LEVER: (61785)	10	1		(0.2)	(0.1)
9-2-24	P1	B	P1	F	1005-992-6658	. GUIDE ASSEMBLY, ACTION SPRING: (62119)	1	1		(0.1)	(0.1)
9-2-25	P1	B	P1	F	1005-992-6665	. SPRING, ACTION: (61581)	1	1		0.1	0.1
9-2-26	P1	B	P1	O	1005-992-6657	. SCREW, BUTT CAP: (92601)	10	1	1.0	0.1	0.1
9-2-27	P1	F	P1	O	1005-017-9549	. STOCK ASSEMBLY, MOLD-ED: w/swivel, black (62302)	1	1	(1.0)	(0.1)	(0.1)
9-2-27 A	P1	B	P	O	1005-654-4058	. SLING, SMALL ARMS: M1 (6544058)	10	1	(1.0)	(2.0)	
9-2-28	P1	B	P1	F	5315-898-9823	. . . PIN, SPRING: tubular, slotted, S, phos-ctd, 1/8 nom dia, 7/8 lg (96906-16562-131)	10	1		(0.1)	(0.1)
9-2-29	P1	B	P1	F	5315-058-6078	. . . PIN, SPRING: tubular, slotted, S, phos-ctd, 1/8 nom dia, 7/16 lg (96906-16562-126)	10	2		(0.4)	(0.1)
9-2-30	P1	B	P1	F	1005-017-9543	. . . SWIVEL, GUN SLING: (62280)	10	2		(0.2)	(0.1)
9-2-31	X1		X1			. . . BASE, SWIVEL: (62097)		1			
9-2-32	X1		X1			. . . STOCK: (62204)		1			
9-2-33	P1	B	P1	O	1005-992-6655	. SPRING, DETENT, TAKE-DOWN PIN: (61692)	10	2	(1.0)	(0.2)	(0.1)
9-2-34	P1	B	P1	O	1005-992-6654	. DETENT, TAKEDOWN PIN: (61698)	10	2	(1.0)	(0.2)	(0.1)
9-2-35	P1	B	P1	O	1005-992-6653	. PIN, TAKEDOWN: (61655)	10	1	(1.0)	(0.2)	(0.1)
9-2-36	P1	B	P1	F	5315-855-7665	. PIN, SPRING: tubular, slot- ted, S, phos-ctd, 0.094 nom dia, 0.812 lg (96906-9047-074)	10	1		0.2	0.1
9-2-37	P1D	F	P1	F	1005-992-7297	. EXTENSION, LOWER RE- CEIVER: (61574)	1	1		0.2	0.1
9-2-38	P1	B	P1	F	1005-992-6651	. RETAINER, BUFFER: (61582)	10	1		(0.2)	(0.1)
9-2-39	P1	B	P1	F	1005-992-6652	. SPRING, BUFFER RE- TAINER: (61694)	10	1		(0.2)	(0.1)
9-2-40	P1	B	P1	F	5315-058-6081	. PIN, SPRING: tubular, slotted, S, phos-ctd, 1/8 nom dia, 5/8 lg (96906-16562-129)	10	1		(0.1)	(0.1)
9-2-41	P1	B	P1	F	1005-992-7299	. GUARD, TRIGGER: (61970)	1	1		(0.1)	(0.1)
9-2-42	X	D	X			. RECEIVER, LOWER: (62300)		1			

WE 13639

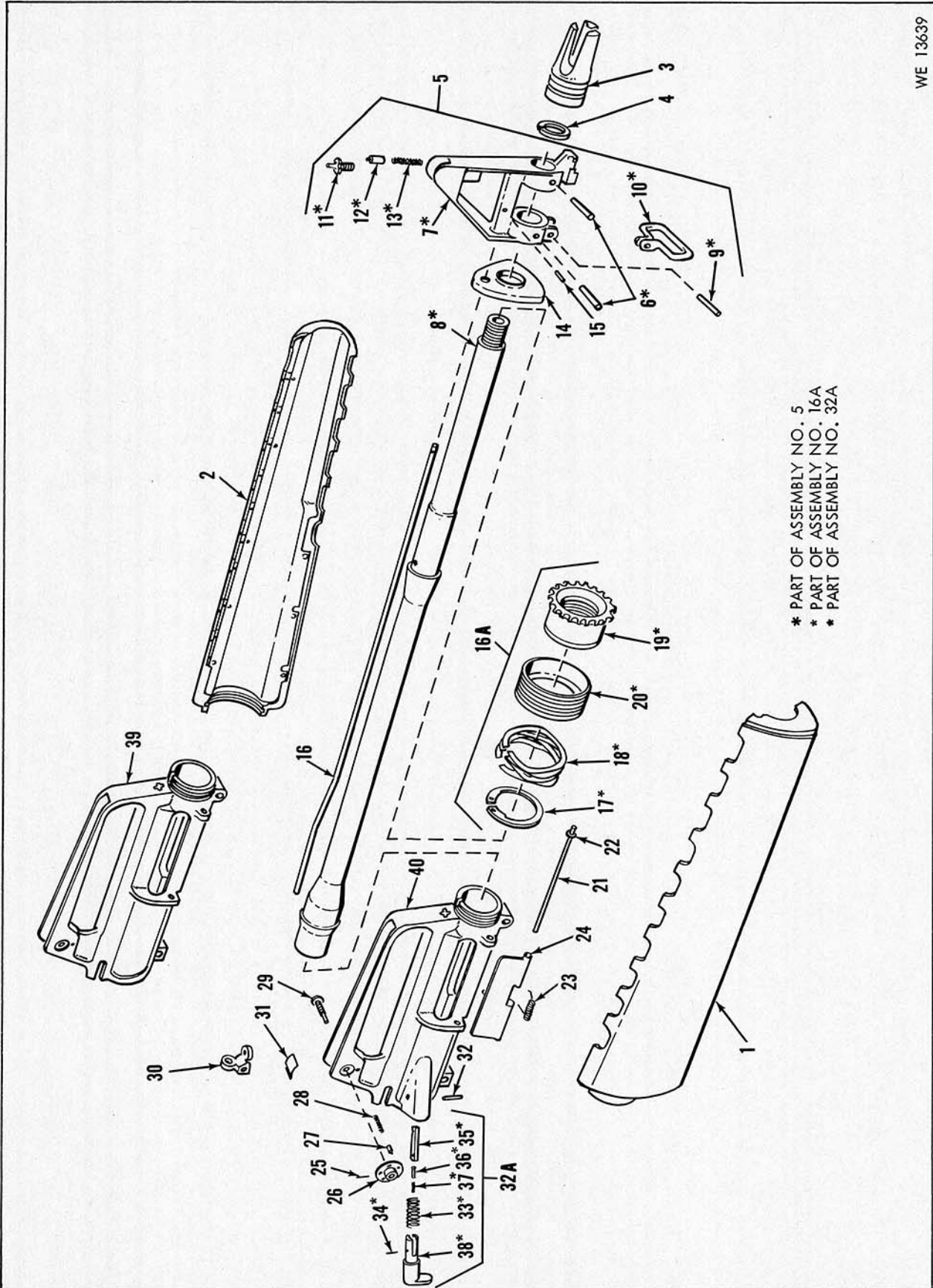

- \* PART OF ASSEMBLY NO. 5
- \* PART OF ASSEMBLY NO. 16A
- \* PART OF ASSEMBLY NO. 32A

Figure 9-3. Upper Receiver Group

(1) Figure and Index No.	(2) SOURCE AND MAINT CODES				(3) FEDERAL STOCK NO.	(4) DESCRIPTION	(5) Unit of Issue /DS & GS Support	(6) Quantity Incorporated in Unit	(7) 15 - DAY MAINT ALLOW PER 100 EQUIPMENT		
	USAF		ARMY						(a) Organizational	(b) Direct Support	(c) General Support
	(a)	(b)	(c)	(d)							
	Source	Maintenance Repair Level	Source	Maintenance Level							
9-3											
9-3-1	P1	B	P1	O	1005-056-2252	UPPER RECEIVER GROUP GUARD, HAND, GUN: R.H. black (62198)	1	1	(1.0)	(0.4)	(0.1)
9-3-2	P1	B	P1	O	1005-056-2251	GUARD, HAND, GUN: L.H. black (62196)	1	1	(1.0)	(0.4)	(0.1)
9-3-3	P1	B	P1	F	1005-056-2248	SUPPRESSOR, FLASH: (62182)	1	1		0.1	0.1
9-3-4	P1	B	P1	F	1005-992-7280	WASHER, LOCK, FLASH SUPPRESSOR: (62126)	10	1		0.4	0.1
9-3-5	P1D	F	P1	F	1005-056-2253	BARREL AND SIGHT AS- SEMBLY: (62206)	1	1		(0.2)	(0.1)
9-3-6	P1	B	P1	F	1005-979-3926	PIN, FRONT SIGHT, TAPERED: (62086)	10	2		(0.2)	(0.1)
9-3-7	X1	F	X1			SIGHT, FRONT: (62068)	1				
9-3-8	X1	F	X1			BARREL ASSEMBLY: (62180)	1				
9-3-9	P1	B	P1	F	5315-058-6078	PIN, SPRING: tubular, slotted, S, phos-ctd 1/8 nom dia, 7/16 lg (96906-16562-126) See allowance under item 9-2-29.	10	1			
9-3-10	P1	B	P1	F	1005-017-9543	SWIVEL, GUN SLING: upper and lower receiver (62280) See allowance under item 9-2-30.	10	2			
9-3-11	P1	B	P1	F	1005-979-3929	POST, FRONT SIGHT: (61706)	1	1		(0.1)	(0.1)
9-3-12	P1	B	P1	F	1005-979-3930	DETENT, FRONT SIGHT: (61705)	10	1		(0.1)	(0.1)
9-3-13	P1	B	P1	F	1005-979-3931	SPRING, FRONT SIGHT, DETENT: (61709)	10	1		(0.1)	(0.1)
9-3-14	P1	B	P1	F	1005-979-3924	CAP, HAND GUARD: (62087)	1	1		0.2	0.1
9-3-15	P1	B	P1	F	5315-058-0644	PIN SPRING: tubular, slotted, S, phos-ctd, 5/64 nom dia, 5/16 lg (96906- 16562-106)	10	1		(0.1)	(0.1)
9-3-16	P1	B	P1	F	1005-978-1038	TUBE, GAS: (61645)	1	1		(0.1)	(0.1)
9-3-16 A	X1		X1			BARREL NUT ASSEMBLY: (62113)	1	1			
9-3-17	P1	B	P1	F	5340-999-0863	RING, RETAINING: ex- ternal, inverted (96906-16626-3137)	1	1		0.1	0.1
9-3-18	P1	B	P1	F	1005-978-1036	SPRING, SLIP RING, HAND GUARD: (61962)	10	1		(0.1)	(0.1)
9-3-19	P1	B	P1	F	1005-978-1034	NUT, BARREL: (61902)	1	1		0.1	0.1
9-3-20	P1	B	P1	F	1005-978-1035	RING, SLIP, HAND GUARD: (61901)	1	1		0.1	0.1
9-3-21	P1	B	P1	F	1005-978-1023	PIN, EJECTION PORT COVER: (61658)	10	1		0.1	0.1

(1) Figure and Index No.	(2) SOURCE AND MAINT CODES				(3) FEDERAL STOCK NO.	(4) DESCRIPTION	(5) Unit of Issue / DS & GS Support	(6) Quantity Incorporated in Unit	(7) 15 - DAY MAINT ALLOW PER 100 EQUIPMENT		
	USAF		ARMY						(a) Organizational	(b) Direct Support	(c) General Support
	(a) Source	(b) Maintenance Repair Level	(c) Source	(d) Maintenance Level							
9-3-22	P1	B	P1	F	5340-999-0864	. RING, RETAINING, EXTERNAL, CRESCENT: ext, reduced section type, S, phos-ctd, 0.102 free id (96906-16632-3012)	10	1		0.2	0.1
9-3-23	P1	B	P1	F	1005-978-1025	. SPRING, EJECTION PORT COVER: (61518)	10	1		0.2	0.1
9-3-24	P1	B	P1	F	1005-978-1022	. COVER EJECTION PORT: (62112)	10	1		0.2	0.1
9-3-25	P1	B	P1	F	5315-282-3642	. PIN, SPRING: tubular, slotted, S, phos-ctd, 1/16 nom dia, 1/4 lg (96906-16562-96) See allowance under item 9-1-14A.	10	1			
9-3-26	P1	B	P1	F	1005-978-1029	. DRUM, REAR SIGHT WINDAGE: (61703)	1	1		0.1	0.1
9-3-27	P1	B	P1	F	1005-978-1030	. DETENT, REAR SIGHT: (61755)	10	1		(0.1)	(0.1)
9-3-28	P1	B	P1	F	1005-978-1032	. SPRING, DETENT, REAR SIGHT: (61754)	10	1		(0.1)	(0.1)
9-3-29	P1	B	P1	F	1005-978-1028	. SCREW, REAR SIGHT WINDAGE: (61702)	1	1		0.2	0.1
9-3-30	P1	B	P1	F	1005-978-1026	. SIGHT, REAR: (61700)	1	1		0.2	0.1
9-3-31	P1	B	P1	F	1005-978-1027	. SPRING, REAR SIGHT: (61708)	10	1		0.1	0.1
9-3-32			P1	F	5315-840-3812	. PIN, SPRING: tubular slotted, S, phos-ctd, 3/32 nom dia, 5/8 lg (96906-16562-121)	10	1		(0.1)	(0.1)
9-3-32 A	X1		X1			. FORWARD ASSIST ASSEMBLY: (62225)	1	1			
9-3-33			P1	F	1005-017-9541	. . SPRING, PLUNGER: XM16E1 (62271)	1	1		(0.1)	(0.1)
9-3-34			P1	F	5315-282-3642	. . PIN, SPRING: tubular, slotted, S, phos-ctd, 1/16 nom dia, 1/4 lg (96906-16562-96) See allowances under item 9-1-14A.	10	1			
9-3-35			P1	F	1005-017-9539	. . PAWL, FORWARD ASSIST: XM16E1(62269)	1	1		(0.1)	(0.1)
9-3-36			P1	F	1005-017-9540	. . DETENT, PAWL: XM16E1 (62270)	10	1		(0.1)	(0.1)
9-3-37			P1	F	1005-523-8084	. . SPRING, BOLT: XM16E1, (50381)	10	1		(0.1)	(0.1)
9-3-38			P1	F	1005-017-9538	. . PLUNGER ASSEMBLY: XM16E1 (62266)	1	1		0.1	0.1
9-3-39	P1D	F			1005-017-9550	. RECEIVER, UPPER: M16 (62306)	1	1		0.1	0.1
9-3-40			P1	F	1005-017-9542	. RECEIVER, UPPER: XM16E1 (62278)	1	1		(0.2)	(0.1)

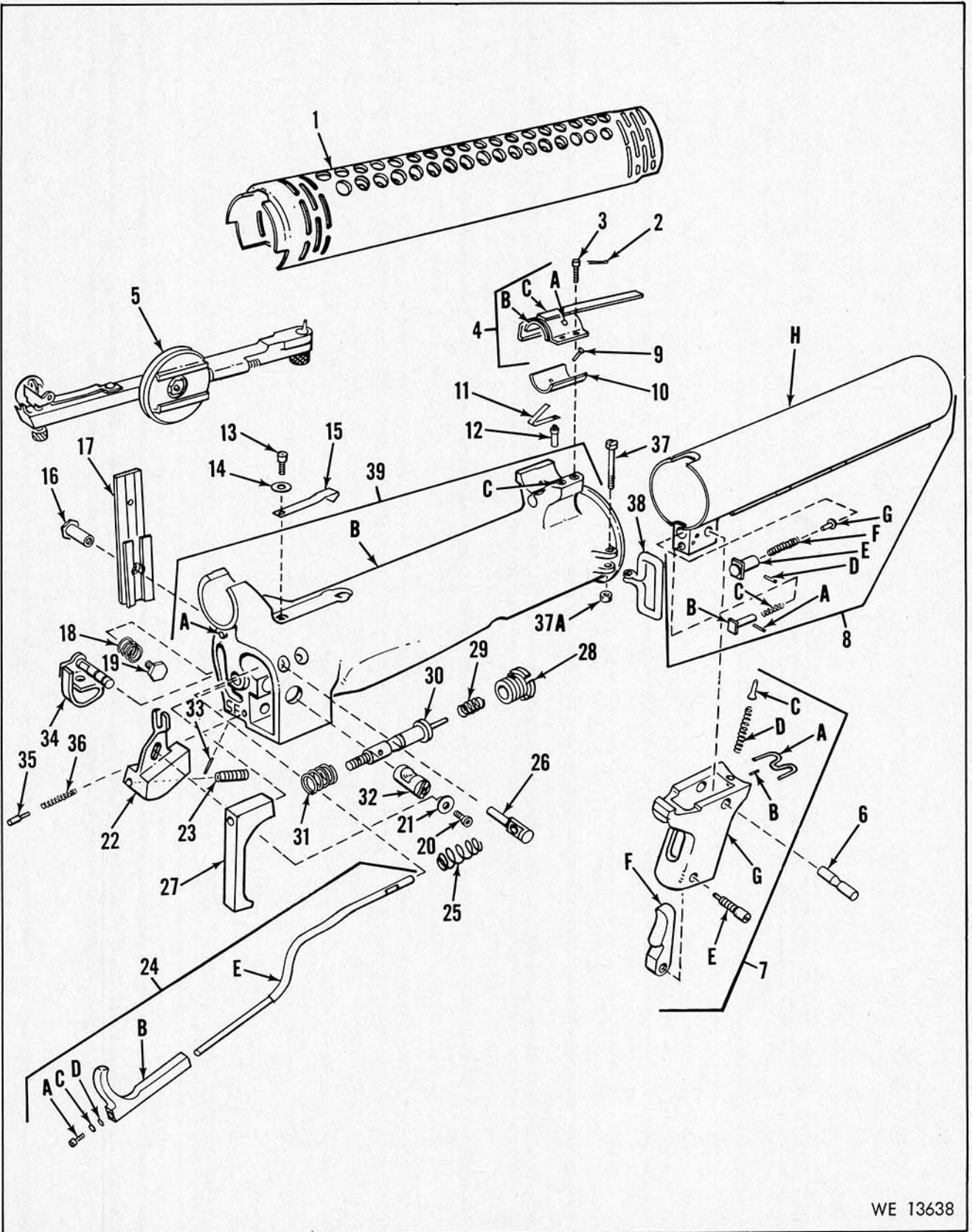

WE 13638

Figure 9-4. Major Groups, Assemblies and Attaching Parts.

(1) Figure and Index No.	(2) SOURCE AND MAINT CODES				(3) FEDERAL STOCK NO.	(4) DESCRIPTION	(5) Unit of Issue/DS & GS Support	(6) Quantity Incorporated in Unit	(7) 15 - DAY MAINT ALLOW PER 100 EQUIPMENT		
	USAF		ARMY						(a) Organizational	(b) Direct Support	(c) General Support
	(a)	(b)	(c)	(d)							
	Source	Maintenance Repair Level	Source	Maintenance Level							
				R	1010-912-3014	LAUNCHER, GRENADE, 40-MILLIMETER: XM148, single shot, rifle mounted, detachable, w/adjustable sight and extension trigger, w/e (5910329)					
94						MAJOR GROUPS, ASSEMBLIES AND ATTACHING PARTS					
941	P1	B	P1	F	1010-918-6240	. GUARD, HAND, GRENADE LAUNCHER: (56296)	1	1		(0.4)	(0.1)
942	P1	B	P1	O	5315-236-8346	. PIN, COTTER: (96906-24665-7)	1	1	1.0	3.8	1.2
943	P1	B	P1	O	5305-912-4007	. SCREW, FRONT MOUNT: (56229)	1	2	(1.0)	(0.4)	(0.1)
944	P1	B	P1	O	1010-918-8128	. CLAMP AND HEAT SHIELD ASSEMBLY: front mount (56252)	1	1	(1.0)	(0.4)	(0.1)
944 A	P1	B	P1	F	5320-918-8107	. . RIVET, SOLID: front mount (56253)	1	1		(0.4)	(0.1)
944 B	X1		X1			. . SHIELD, HEAT: (56251)		1			
944 C	X1		X1			. . CLAMP, FRONT MOUNT ASSEMBLY: (56294)		1			
945	P1	B	P1	FR	1010-918-8117	. SIGHT ASSEMBLY: (56260)	1	1		(0.2)	(0.1)
946	P1	B	P1	O	5315-918-8093	. PIN, PIVOT: grip (56224)	1	1	(1.0)	(0.4)	(0.1)
947						. PISTOL GRIP GROUP:		1			
947 A	P1	B	P1	F	1010-918-6237	. . FINGER GUARD, GRIP: (56226)	1	1		(0.4)	(0.1)
947 B	P1	B	P1	F	5315-918-8095	. . PIN, ROLL: (56290)	10	1		(0.4)	(0.1)
947 C	P1	B	P1	F	1010-918-6238	. . RETAINER, CARTRIDGE: grip (56227)	1	1		(0.4)	(0.1)
947 D	P1	B	P1	F	1010-918-6234	. . SPRING, HELICAL, COMPRESSION: plunger, cartridge retainer (56230)	10	2		(0.8)	(0.2)
947 E	P1	B	P1	F	5305-923-4260	. . SCREW, GRIP RELEASE PIVOT: (56316)	1	1		(0.4)	(0.1)
947 F	P1	B	P1	F	1010-921-0579	. . GRIP RELEASE: (56315)	1	1		(0.4)	(0.1)
947 G	P1	B	P1	F	1010-918-6236	. . GRIP, GRENADE LAUNCHER: (56292)	1	1		(0.2)	(0.1)
948						. BARREL GROUP:		1			
948 A	P1	B	P1	F	5315-918-8095	. . PIN, ROLL: (56290) See allowances under item 9-4-7B		1			
948 B	P1	B	P1	F	1010-921-0578	. . PLUNGER, GRIP LOCK: (56314)	1	1		(0.4)	(0.1)
948 C	P1	B	P1	F	1010-920-7601	. . SPRING, HELICAL, COMPRESSION: plunger, cartridge retainer (56266)	1	1		(1.0)	(0.3)

(1) Figure and Index No.	(2) SOURCE AND MAINT CODES				(3) FEDERAL STOCK NO.	(4) DESCRIPTION	(5) Unit of Issue/DS & GS Support	(6) Quantity Incorporated in Unit	(7) 15 - DAY MAINT ALLOW PER 100 EQUIPMENT		
	USAF		ARMY						(a) Organizational	(b) Direct Support	(c) General Support
	(a) Source	(b) Maintenance Repair Level	(c) Source	(d) Maintenance Level							
948 D	P1	B	P1	O	5315-918-8095	. . PIN, ROLL: (56290) See allowances under item 9-4-7B	1				
948 E	P1	B	P1	F	1010-918-6235	. . PLUNGER, DETENT: pivot pin lock (56223)	1	1	(0.4)	(0.1)	
948 F	P1	B	P1	O	1010-918-6234	. . SPRING, HELICAL, COMPRESSION: plunger, cartridge retainer (56230) See allowances under item 9-4-7C	1	1			
948 G	P1	B	P1	F	5315-918-8092	. . PIN, LOCK: (56221)	1	1	(0.4)	(0.1)	
948 H	P1	B	P1	F	1010-918-6233	. . BARREL, GRENADE LAUNCHER: (56220)	1	1	(0.4)	(0.1)	
949	P1	B	P1	F	5320-918-8107	. RIVET, SOLID: front mount (56253)	1	1	(0.4)	(0.1)	
9410	P1	B	P1	F	1010-918-8127	. SHIELD, HEAT, FRONT MOUNT: lower half (56310)	1	1	(0.4)	(0.1)	
9411	P1	B	P1	F	1010-918-8116	. SPRING, BARREL, RETAINING PIN: (56248)	1	1	(0.4)	(0.1)	
9412	P1	B	P1	F	5315-918-8094	. PIN, BARREL RETAINING: (56250)	1	1	(0.4)	(0.1)	
9413	P1	B	P1	O	5305-912-4010	. SCREW, SEAR LEVER: (56247)	1	1	(1.0)	(0.4) (0.1)	
9414	P1	B	P1	O	5310-918-8100	. WASHER, SEAR LEVER, EXTRACTOR AND SIGHT: (56246)	1	1	(1.0)	(0.4) (0.1)	
9415	P1	B	P1	O	1010-918-6228	. EXTRACTOR, GRENADE CARTRIDGE: (56214)	1	1	(1.0)	(0.4) (0.1)	
9416	P1	B	P1	F	5306-919-1923	. BOLT, SLIDE, SIGHT: (56283)	1	1	(0.4)	(0.1)	
9417	P1	B	P1	F	1010-918-8125	. SLIDE, SIGHT: (56304)	1	1	(0.2)	(0.1)	
9418	P1	B	P1	F	1010-918-8126	. SPRING, HELICAL, COMPRESSION: (56284)	1	1	(0.4)	(0.1)	
9419	P1	B	P1	F	5310-918-8105	. NUT, SIGHT SLIDE: (56285)	1	1	(0.4)	(0.1)	
9420	P1	B	P1	O	5305-912-4010	. SCREW, SEAR LEVER: (56247) See allowances under item 9-4-13	1	1			
9421	P1	B	P1	O	5310-918-8100	. WASHER, SEAR LEVER, EXTRACTOR AND SIGHT: (56246) See allowances under item 9-4-14	1	1			
9422	P1	B	P1	F	1010-918-8115	. LEVER, SEAR: (56245)	1	1	(0.4)	(0.1)	
9423	P1	B	P1	F	5305-999-2770	. SETSCREW: nylock, safety (56309)	1	1	(0.4)	(0.1)	
9424						. TRIGGER GROUP	1	1			

(1) Figure and Index No.	(2) SOURCE AND MAINT CODES				(3) FEDERAL STOCK NO.	(4) DESCRIPTION	(5) Unit of Issue/DS & GS Support	(6) Quantity Incorporated in Unit	(7) 15 - DAY MAINT ALLOW PER 100 EQUIPMENT		
	USAF		ARMY						(a) Organizational	(b) Direct Support	(c) General Support
	(a)	(b)	(c)	(d)							
	Source	Maintenance Repair Level	Source	Maintenance Level							
9424 A	P1	B	P1	O	5305-912-4010	. SCREW, SEAR LEVER: (56247) See allowances under item 9-4-13	1				
9424 B	P1	B	P1	F	1010-918-8113	. TRIGGER: (56242)	1	1	(0.4)	(0.1)	
9424 C	P1	B	P1	F	1010-918-8109	. RING, TRIGGER: (56238)	1	1	(0.4)	(0.1)	
9424 D	P1	B	P1	F	1010-918-8110	. WASHER, THRUST: trigger bar (56239)	1	1	(0.4)	(0.1)	
9424 E	P1	B	P1	F	1010-918-8112	. EXTENSION, TRIGGER: (56297)	1	1	(0.4)	(0.1)	
9425	P1	B	P1	O	1010-921-0581	. SPRING, HELICAL, COMPRESSION: trigger return (56317)	1	1	(1.0)	(0.4)	(0.1)
9426	P1	B	P1	O	1010-918-8111	. SUPPORT, TRIGGER EXTENSION: (56240)	1	1	(1.0)	(0.4)	(0.1)
9427	P1	B	P1	O	1010-999-2772	. LEVER, COCKING: (56349)	1	1	(1.0)	(0.4)	(0.1)
9428	P1	B	P1	O	1010-918-6229	. RETAINER, FIRING PIN: (56216)	1	1	(1.0)	(0.8)	(0.2)
9429	P1	B	P1	O	1010-918-6230	. SPRING, HELICAL, COMPRESSION: buffer (56217)	1	1	(1.0)	(0.4)	(0.1)
9430	P1	B	P1	F	1010-918-6241	. PIN, FIRING: (56237)	1	1		(0.4)	(0.1)
9431	P1	B	P1	O	1010-918-6231	. SPRING, HELICAL, COMPRESSION: firing pin (56218)	1	1	(1.0)	(0.4)	(0.1)
9432	P1	B	P1	F	1010-918-8114	. SEAR: (56244)	1	1		(0.4)	(0.1)
9433	P1	B	P1	O	5315-918-8095	. PIN, ROLL: (56290) See allowances under item 9-4-7B	1	1			
9434	P1	B	P1	F	1010-999-2771	. SAFETY ASSEMBLY: (56318)	1	1		(0.4)	(0.1)
9435	P1	B	P1	F	1010-918-8119	. PLUNGER, DETENT: front and rear sight and safety (56267)	1	1		(0.4)	(0.1)
9436	P1	B	P1	F	1010-920-7601	. SPRING, HELICAL, COMPRESSION: sight assembly and safety (56266) See allowances under item 9-4-8C		1			
9437	P1	B	P1	O	5305-923-4261	. SCREW, FRONT SLING RETAINING: (56338)	1	1	(1.0)	(0.4)	(0.1)
9437 A	P1	B	P1	O	5310-924-2074	. NUT, FRONT SLING RETAINING SCREW: (56339)	1	1	(1.0)	(0.4)	(0.1)

(1) Figure and Index No.	(2) SOURCE AND MAINT CODES				(3) FEDERAL STOCK NO.	(4) DESCRIPTION	(5) Unit of Issue/DS & GS Support	(6) Quantity Incorporated in Unit	(7) 15 - DAY MAINT ALLOW PER 100 EQUIPMENT		
	USAF		ARMY						(a) Organizational	(b) Direct Support	(c) General Support
	(a) Source	(b) Maintenance Repair Level	(c) Source	(d) Maintenance Level							
9438	P1	B	P1	F	1005-017-9543	. SWIVEL, GUN SLING: upper and lower receiver (62280) See allowances under item 9-3-10					
9439	X1		X1			. HOUSING ASSEMBLY: (56231)	1				
9439 A	P1	B	P1	F	5315-918-8091	. . PIN, LOCK: rear mount (56212)	1	1	(0.4)	(0.1)	
9439 B	X1		X1			. . HOUSING: (56232)		1			
9439 C	X1		X1			. . INSERT, FRONT MOUNT SCREW: (56213)		2			

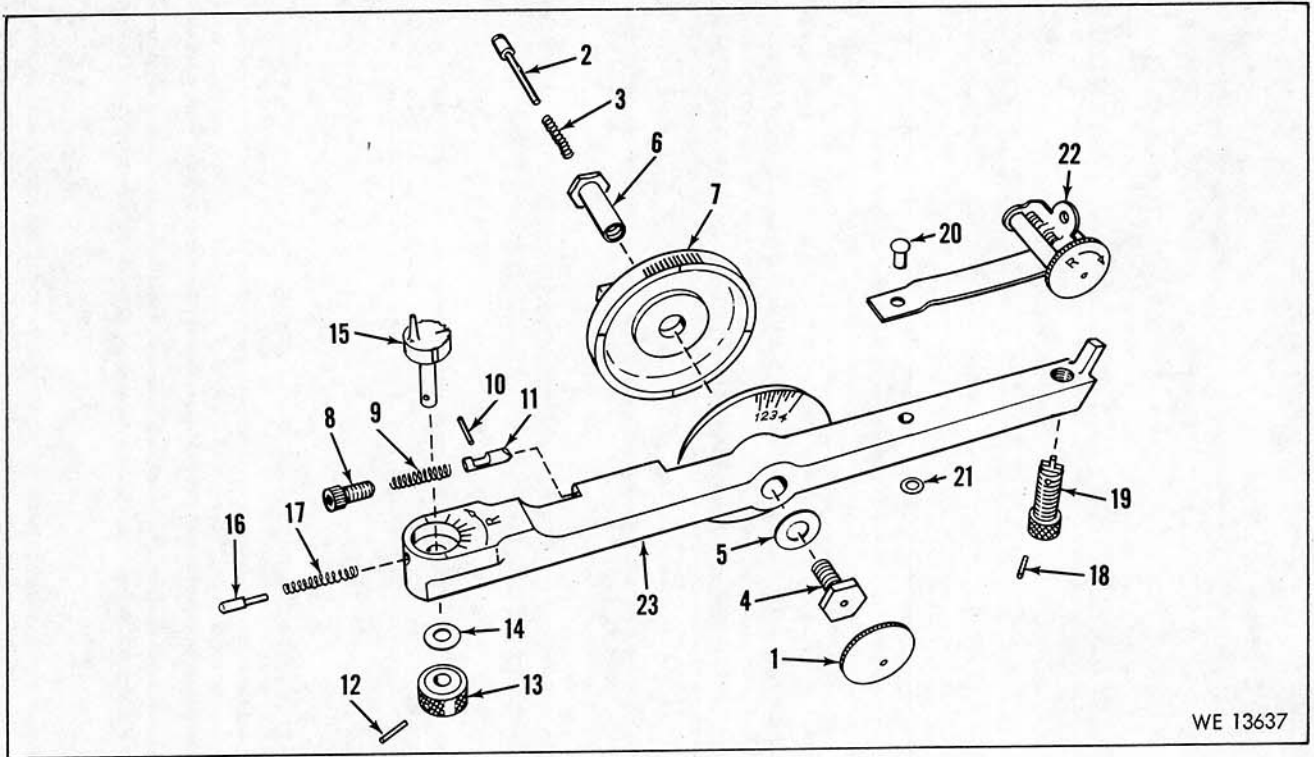

Figure 9-5. Sight Assembly

(1) Figure and Index No.	(2) SOURCE AND MAINT CODES				(3) FEDERAL STOCK NO.	(4) DESCRIPTION	(5) Unit of Issue/DS & GS Support	(6) Quantity Incorporated in Unit	(7) 15 - DAY MAINT ALLOW PER 100 EQUIPMENT		
	USAF		ARMY						(a) Organizational	(b) Direct Support	(c) General Support
	(a)	(b)	(c)	(d)							
	Source	Maintenance Repair Level	Source	Maintenance Level							
95-1	P1	B	P1	F	1010-918-8124	SIGHT ASSEMBLY 56260 • BUTTON, LOCKING: (56281)	1	1		(0.4)	(0.1)
95-2	P1	B	P1	F	5306-918-8098	• BOLT, LOCKING: (56280)	1	1		(0.4)	(0.1)
95-3	P1	B	P1	F	1010-920-7601	• SPRING, HELICAL, COMPRESSION: (56266) See allowances under item 9-4-8C	1	1		(1.0)	(0.3)
95-4	P1	B	P1	F	5310-918-8104	• NUT, FRICTION: (56276)	1	1		(0.4)	(0.1)
95-5	P1	B	P1	F	5310-918-8103	• WASHER, SPRING TENSION: sight friction bolt (56275)	1	1		(0.4)	(0.1)
95-6	P1	B	P1	F	5306-918-8097	• BOLT, FRICTION: (56279)	1	1		(0.4)	(0.1)
95-7	P1	B	P1	F	1010-930-2589	• BASE, SIGHT: (56340)	1	1		(0.4)	(0.1)
95-8	P1	B	P1	F	5305-915-5712	• SCREW, ELEVATION DE-TENT ADJUSTING: (56274)	1	1		(0.4)	(0.1)

(1) Figure and Index No.	(2) SOURCE AND MAINT CODES				(3) FEDERAL STOCK NO.	(4) DESCRIPTION	(5) Unit of Issue/DS & GS Support	(6) Quantity Incorporated in Unit	(7) 15 - DAY MAINT ALLOW PER 100 EQUIPMENT		
	USAF		ARMY						(a) Organizational	(b) Direct Support	(c) General Support
	(a) Source	(b) Maintenance Repair Level	(c) Source	(d) Maintenance Level							
9-5-9	P1	B	P1	F	1010-918-8118	. SPRING, HELICAL, COMPRESSION: (56265)	10	1		(0.4)	(0.1)
9-5-10	P1	B	P1	F	5315-918-8095	. PIN, ROLL: (56290) See allowances under item 9-4-7B		1			
9-5-11	P1	B	P1	F	1010-918-8121	. PLUNGER, DETENT: elevation (56273)	1	1		(0.4)	(0.1)
9-5-12	P1	B	P1	F	5315-918-8095	. PIN, ROLL: (56290) See allowances under item 9-4-7B		1			
9-5-13	P1	B	P1	F	5355-918-8108	. KNOB: front sight adjusting (56270)	1	1		(0.4)	(0.1)
9-5-14	P1	B	P1	F	5310-918-8102	. WASHER, SPRING TENSION: front sight adjusting knob (56269)	1	1		(0.4)	(0.1)
9-5-15	P1	B	P1	F	1010-918-8120	. SIGHT, FRONT: (56268)	1	1		(0.4)	(0.1)
9-5-16	P1	B	P1	F	1010-918-8119	. PLUNGER, DETENT: front and rear sight and safety (56267) See allowances under item 9-4-35		1			
9-5-17	P1	B	P1	F	1010-920-7601	. SPRING, HELICAL, COMPRESSION: (56266) See allowances under item 9-4-8C		1			
9-5-18	P1	B	P1	F	5315-918-8096	. PIN, ROLL: (56291)	10	1		(0.1)	(0.1)
9-5-19	P1	B	P1	F	5305-912-4011	. SCREW, ELEVATION ADJUSTING: (56271)	1	1		(0.4)	(0.1)
9-5-20	P1	B	P1	F	5320-918-8106	. . RIVET, SOLID: rear sight mounting (56263)	1	1		(0.2)	(0.1)
9-5-21	P1	B	P1	O	5310-918-8100	. . WASHER, SEAR LEVER, EXTRACTOR AND SIGHT: (56246) See allowances under item 9-4-14		1			
9-5-22	P1	B	P1	F	1010-920-7600	. . SIGHT, REAR: (56262)	1	1		(0.2)	(0.1)
9-5-23	X1		X1			. . BAR, SIGHT: (56311)		1			

(1) Figure and Index No.	(2) SOURCE AND MAINT CODES				(3) FEDERAL STOCK NO.	(4) DESCRIPTION	(5) Unit of Issue/DS & GS Support	(6) Quantity Incorporated in Unit	(7) 15 - DAY MAINT ALLOW PER 100 EQUIPMENT		
	USAF		ARMY						(a) Organizational	(b) Direct Support	(c) General Support
	(a) Source	(b) Maintenance Repair Level	(c) Source	(d) Maintenance Level							
1-1					1005-073-9421	BASIC ISSUE ITEMS (ARMY)  ITEMS MAY BE REQUISITIONED AS REQUIRED FOR REPLACEMENT UNDER THEIR INDIVIDUAL STOCK NUMBERS  RIFLE, 5.56-MM: XM16E1 w/e (8427000)					
1-3					1005-992-6676	COMPOSED OF: 1-RIFLE, 5.56-MM: XM16E1 (62400) (w/magazine assembly and sling) 1-BIPOD ASSEMBLY: XM3 (62122)					
1-7					1005-903-1296	1-BRUSH, CLEANING, SMALL ARMS: bore (11686340)					
1-12					1005-999-1435	1-BRUSH, CLEANING, SMALL ARMS: chamber (8432358)					
1-4					1005-999-2340	1-CASE, BIPOD: (62309)					
1-5					1005-791-3377	1-CASE, LUBRICANT: (7790995)					
9-2-1					1005-056-2237	6-MAGAZINE ASSEMBLY: aluminum (20 cartridge capacity) (62103)					
1-6					1005-999-1295	1-ROD, CLEANING, SMALL ARMS: M11E1 (11686326)					

(1) Figure and Index No.	(2) SOURCE AND MAINT CODES				(3) FEDERAL STOCK NO.	(4) DESCRIPTION	(5) Unit of Issue/DS & GS Support	(6) Quantity Incorporated in Unit	(7) 15 - DAY MAINT ALLOW PER 100 EQUIPMENT		
	USAF		ARMY						(a) Organizational	(b) Direct Support	(c) General Support
	(a) Source	(b) Maintenance Repair Level	(c) Source	(d) Maintenance Level							
12-1					1010-912-3014	LAUNCHER, GRENADE, 40-MILLIMETER: XM148, single shot rifle mounted; detachable, w/adjustable sight and extension trigger, w/e (5910329)					
						COMPOSED OF:					
12-2					1010-999-3401	1-LAUNCHER, GRENADE, 40-MM, Complete (less sight and hand guard) (56222)					
94-1					1010-918-6240	1-CASE, CARRYING, SIGHT: (2-2-248)					
94-5					1010-918-8117	1-GUARD, HAND, GRENADE LAUNCHER: (56296)					
12-2					1010-918-8117	1-SIGHT ASSEMBLY: (56260)					
12-2					4933-999-8554	1-TOOL, COMBINATION: (8430382)					

(1) Figure and Index No.	(2) SOURCE AND MAINT CODES				(3) FEDERAL STOCK NO.	(4) DESCRIPTION	(5) Unit of Issue/DS & GS Support	(6) Quantity Incorporated in Unit	(7) 15 - DAY MAINT ALLOW PER 100 EQUIPMENT		
	USAF		ARMY						(a) Organizational	(b) Direct Support	(c) General Support
	(a) Source	(b) Maintenance Repair Level	(c) Source	(d) Maintenance Level							
					TOOLS AND EQUIPMENT RIFLES, M16 AND XM16E1  ITEMS MAY BE REQUISITIONED AS REQUIRED FOR REPLACEMENT UNDER THEIR INDIVIDUAL STOCK NUMBERS						
1-3				1005-992-6676	BIPOD ASSEMBLY: XM3(62122)	1		(1)	-		
1-7				1005-903-1296	BRUSH, CLEANING, SMALL ARMS: bore (11686340)	1		(1)	-		
1-12				1005-999-1435	BRUSH, CLEANING SMALL ARMS: chamber (8432358)	1		(1)	-		
1-4				1005-017-9647	CASE, BIPOD: (62309)	1		(1)	-		
1-5				1005-791-3377	CASE, LUBRICANT: (7790995)	1		(1)	-		
1-6				1005-999-1295	ROD, CLEANING, SMALL ARMS: M11E1 (11686326)	1		(1)	-		
				1005-912-4248	SWAB, SMALL, ARMS CLEANING: 1000 per package (11686408)	1		(1)	-		
				4933-056-7106	TOOL SET, DIRECT AND GENERAL SUPPORT MAINTENANCE (8426685)  COMPOSED OF:	1			*	*	
1-9			R	4933-070-9151	1-FIXTURE, BARREL REMOVER: vise jaws (11010032)						
1-13			R	4933-912-3409	1-GAGE, BARREL EROSION: (7799792)						
1-10			R	4933-070-7815	1-GAGE, FIRING PIN PROTRUSION: (7799735)						
1-11			R	4933-070-7814	1-GAGE, HEADSPACE: field type (7799734)						
1-8			R	4933-070-9152	1-WRENCH, COMBINATION: barrel nut and flash suppressor (11010033)						

(1) Figure and Index No.	(2) SOURCE AND MAINT CODES				(3) FEDERAL STOCK NO.	(4) DESCRIPTION	(5) Unit of Issue /DS & GS Support	(6) Quantity Incorporated in Unit	(7) 15 - DAY MAINT ALLOW PER 100 EQUIPMENT		
	USAF		ARMY						(a) Organizational	(b) Direct Support	(c) General Support
	(a) Source	(b) Maintenance Repair Level	(c) Source	(d) Maintenance Level							
					LAUNCHER, GRENADE, XM148						
12-2				1010-474-5466	BRUSH, CLEANING: M79 (7790665)	1		(1)	(2.3)		
12-2				1005-610-8828	BRUSH, CLEANING, SMALL ARMS: M6 chamber (6108828)	1		(1)	(2.0)		
12-2				1010-999-3401	CASE, CARRYING, SIGHT: (2-2-248)	1		1	(0.4)		
12-2				1010-474-5465	THONG, CLEANING BRUSH: M79 (7790631)	1		(1)	(2.3)		
12-2				4933-999-8554	TOOL, COMBINATION: (8430382)	1		(1)	(2.0)		
12-2				4933-921-5482	WRENCH ASSEMBLY, HEXAGON SOCKET: (56306)	1		1	0.2		
12-2				5120-920-7602	WRENCH, 7/16 OPEN END: (56258)	1		1	0.2		

(1) Figure and Index No.	(2) SOURCE AND MAINT CODES				(3) FEDERAL STOCK NO.	(4) DESCRIPTION	(5) Unit of Issue/DS & GS Support	(6) Quantity Incorporated in Unit	(7) 15 - DAY MAINT ALLOW PER 100 EQUIPMENT		
	USAF		ARMY						(a) Organizational	(b) Direct Support	(c) General Support
	(a)	(b)	(c)	(d)							
	Source	Maintenance Repair Level	Source	Maintenance Level							
					<p>CLEANING AND PRESERVING MATERIALS                      The following items are requisitioned as required</p> <p>8020-244-0153 BRUSH, ARTIST: metal ferrule, flat, chisel edges, 7/16 w, 1-1/8 lg, exposed bristle</p> <p>7920-205-2401 BRUSH, CLEANING, TOOL AND PARTS: rd 100 percent tampico fiber, 1-1/16 at ferrule brush dia, 2-7/8 clear of block brush lg</p> <p>6850-620-0610 CARBON REMOVING COMPOUND: 5 gal can (P-C-111A)</p> <p>CLEANING COMPOUND, SOLVENT: Small arms bore cleaner, solution type (CR)</p> <p>6850-224-6656 2 oz can</p> <p>6850-224-6657 6 oz can</p> <p>6850-224-6658 1 qt can</p> <p>6850-224-6663 1 gal can</p> <p>5350-221-0872 CLOTH, ABRASIVE: Crocus, ferric oxide and quartz, jean-cloth-backing, closed coating, 9w, 11 lg, 50 sh-sleeve (CA)</p> <p>6850-281-1985 DRY CLEANING SOLVENT: (SD) (1 gal can)</p> <p>9150-754-0063 GREASE, RIFLE: Lubriplate 130-A or equal (1 lb can)</p> <p>8010-582-5382 LACQUER: Black (jet) lusterless, type I, color 37038, 16 oz, aerosol can, Spec TT-L-50D, type I, nitro cellulose base</p>						

(1) Figure and Index	(2) SOURCE AND MAINT CODES				(3) FEDERAL STOCK NO.	(4) DESCRIPTION	(5) Unit of Issue/DS & GS Support	(6) Quantity Incorporated in Unit	(7) 15 - DAY MAINT ALLOW PER 100 EQUIPMENT		
	USAF		ARMY						(a) Organizational	(b) Direct Support	(c) General Support
	(a) Source	(b) Maintenance Repair Level	(c) Source	(d) Maintenance Level							
				9150-273-2389	LUBRICATING OIL, GENERAL PURPOSE: (PL special) 4 oz can						
				9150-231-6689	1 qt can						
				9150-292-9689	LUBRICATING OIL, WEAPONS: (LAW) for below zero operations (1 qt can)						
				8030-980-3976	PRIMER, ACTIVATOR: Locquic, grade Q, 6 oz spray can (XM148 Grenade Launcher only)						
					RAG, WIPING: Cotton, for general purpose use						
				7920-234-8465	5 lb bag						
				7920-205-1711	50 lb bale						
				8030-081-2326	SEALING COMPOUND: retaining, single - component, anaerobic, grade H, locking torque - 10/25 inch - lbs (XM148 Grenade Launcher only)						
				8030-081-2341	SEALING COMPOUND: retaining, single component, anaerobic, grade AA (XM148 Grenade Launcher only)						

## CHAPTER X MAINTENANCE ALLOCATION CHART

10-1. GENERAL. Indicates specific maintenance operations performed at the proper maintenance levels. Deviation from maintenance operations allocated in the chart is authorized only upon approval of the commanding officer.

10-2. MAINTENANCE FUNCTIONS. These functions are limited to and defined as follows:

INSPECT	To determine serviceability of an item by comparing its physical and mechanical characteristics with established standards.
SERVICE	To clean, preserve, and lubricate.
INSTALL	To set up for use in an operational environment such as an emplacement, site, or vehicle.
REPLACE	To replace unserviceable items with serviceable assemblies, subassemblies, or parts.
REPAIR	To restore an item to serviceable condition. This includes, but is not limited to inspection, cleaning, preserving, adjusting, replacing, welding, riveting, and strengthening.
ADJUST	To rectify to the extent necessary to bring into proper operating range.

### 10-3. EXPLANATION OF FORMAT.

### Note

10-4. COLUMN 1, GROUP NUMBER. Lists group numbers to identify components and assemblies.

Explanation for numbers used in this column is as follows:

10-5. COLUMN 2, FUNCTIONAL GROUP. Lists the noun names of groups and assemblies.

10-6. COLUMN 3, MAINTENANCE FUNCTIONS. Self-explanatory.

NUMBER	EXPLANATION
1	Operator or Crew
2	Organizational
3	Direct Support
4	General Support

10-7. COLUMN 4, TOOLS AND EQUIPMENT. Tools and equipment which are required to perform the designated function.

10-8. COLUMN 5, REMARKS. Self-explanatory.

MAINTENANCE ALLOCATION CHART  
FOR  
RIFLES, 5.56-MM, M16 AND XM16E1

(1) GROUP NO.	(2) FUNCTIONAL GROUP	(3) MAINTENANCE FUNCTION											(4) TOOLS & EQUIP.	(5) REMARKS
		INSPECT	TEST	SERVICE	ADJUST	ALIGN	CALIBRATE	INSTALL	REPLACE	REPAIR	OVERHAUL	REBUILD		
		1	Magazine Assembly	1	-	1	-	-	-	1	1	3		
2	Bolt Carrier Group	2	-	1	-	-	-	1	3	2	-	-		
3	Upper Receiver Group	2	-	1	-	-	-	3	3	2	-	-		
4	Barrel and Front Sight Assembly	2	-	1	1	-	-	3	3	3	-	-		
5	Rear Sight	2	-	1	1	-	-	3	3	3	-	-		
6	Hand Guard Assembly	2	-	1	-	-	-	1	2	-	-	-		
7	Lower Receiver Group	2	-	1	-	-	-	3	*2	-	-	-		
8	Stock Assembly	2	-	1	-	-	-	2	2	3	-	-		
9	Rifle Bipod	2	-	1	-	-	-	1	3	3	-	-		

\*Pistol grip and retainer screw only.

\* MC I.D. 05538A

MAINTENANCE ALLOCATION CHART  
FOR  
LAUNCHER, GRENADE, 40-MM, XM148

(1)  GROUP NO.	(2)  FUNCTIONAL GROUP	(3)  MAINTENANCE FUNCTION										(4)  TOOLS & EQUIP.	(5)  REMARKS	
		INSPECT	TEST	SERVICE	ADJUST	ALIGN	CALIBRATE	INSTALL	REPLACE	REPAIR	OVERHAUL			REBUILD
		1	Hand Guard	2	-	1	-	-	-	2	3			3
2	Clamp and Heat Shield Assembly	2	-	1	2	-	-	2	2	-	-	-		
3	Sight Assembly	2	-	1	2	-	-	1	3	3	-	-		
4	Pistol Grip Group	2	-	1	-	-	-	1	3	3	-	-		
5	Barrel Group	2	-	1	-	-	-	1	3	3	-	-		
6	Heat Shield	2	-	1	-	-	-	3	3	2	-	-		
7	Barrel Retaining Pin and Spring	2	-	1	-	-	-	3	3	3	-	-		
8	Extractor	2	-	1	-	-	-	1	2	2	-	-		
9	Sight Slide	2	-	1	-	-	-	3	3	3	-	-		
10	Sear Lever	2	-	1	-	-	-	1	2	2	-	-		
11	Trigger Group	2	-	1	2	-	-	1	3	2	-	-		
12	Trigger Extension Support	2	-	1	-	-	-	1	3	3	-	-		
13	Cocking Lever	2	-	1	-	-	-	1	3	2	-	-		
14	Firing Pin Retainer	2	-	1	-	-	-	1	2	2	-	-		
15	Firing Pin	2	-	1	-	-	-	1	3	2	-	-		
16	Sear	2	-	1	-	-	-	1	3	2	-	-		
17	Safety Assembly	2	-	1	-	-	-	3	3	3	-	-		
18	Detent Plunger	2	-	1	-	-	-	3	3	3	-	-		
19	Gun Sling Swivel	2	-	1	-	-	-	2	2	2	-	-		
20	Housing Assembly	2	-	1	-	-	-	2	-	-	-	-		

## CHAPTER XI

### BAYONET-KNIFE, M7 AND BAYONET-KNIFE SCABBARD, M8A1

#### 11-1. GENERAL.

11-2. The bayonet-knife (figure 1-2) is utilized for close combat, guarding of prisoners, riot duty, etc. It can also be used as a general utility knife. The blade has a full cutting edge on the bottom and a 3 1/8" cutting edge on top running from the point. The handle fits comfortably and has a knurled surface for a firm grip. The bayonet-scabbard (figure 1-2) is used to carry the bayonet-knife when not being used on the rifle

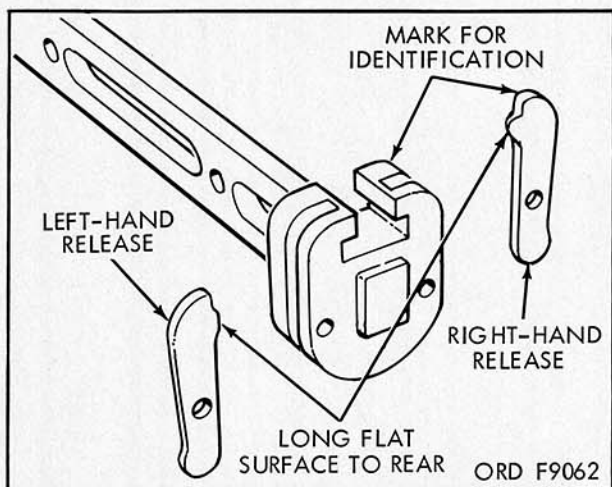

Figure 11-1. Bayonet-Knife Marking and Identification of Releases

#### 11-3. BAYONET.

##### Note

Maintenance allocation chart and replacement parts are located in TM 9-1005-237-15P.

#### 11-4. INSTALLATION.

11-5. Refer to figure 3-3.

#### 11-6. TROUBLE SHOOTING.

11-7. If the bayonet-knife fails to slide over the bayonet stud or can be removed from the rifle without compressing the releases, the releases are probably incorrectly assembled. If the releases are assembled correctly, inspect for a weak or broken release spring.

11-8. DISASSEMBLE/ASSEMBLE. Refer to paragraph 3-28B for operator (user) maintenance.

##### Note

Prior to disassembly, it is recommended that the right hand release and plate be marked to assist in identification when assembling the left and right hand releases (Figure 11-1).

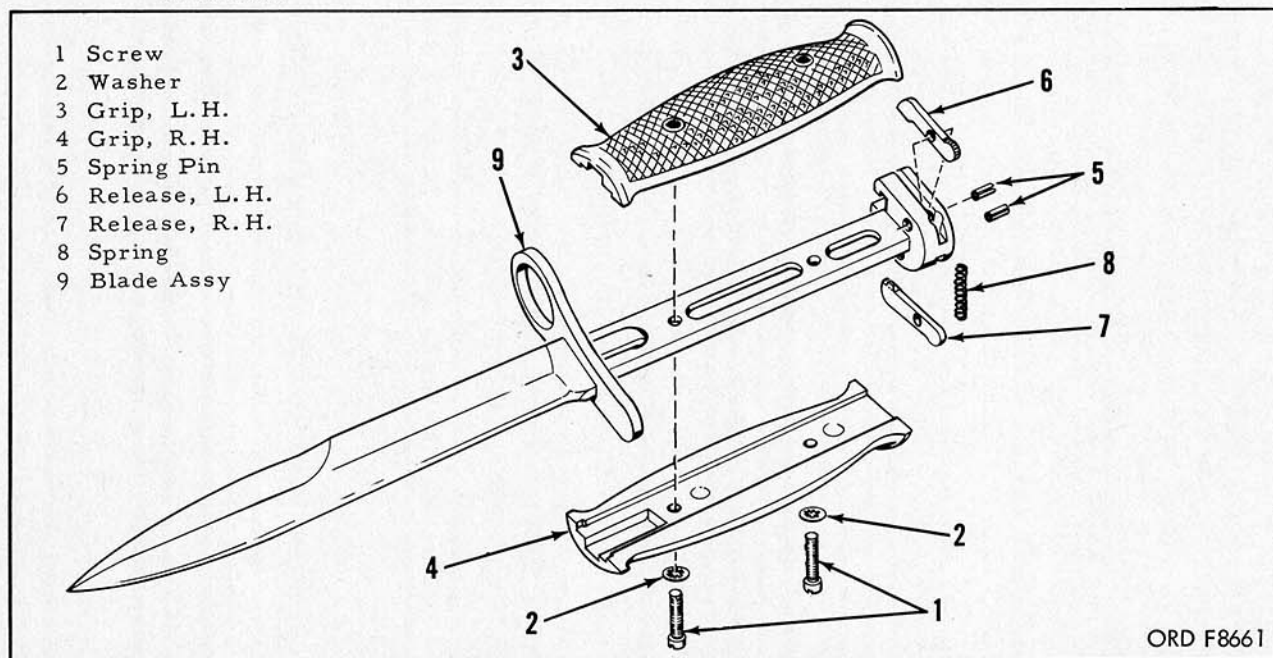

Figure 11-2. Bayonet-Knife M7 - exploded view

11-9. Remove screws (1, figure 11-2) and lock washers (2). Remove left (3) and right-hand grips (4). Remove spring pins (5) and releases (6 & 7). Remove spring (8).

11-10. Assemble in reverse order of disassembly.

**Note**

The grips may be installed on either side of bayonet-knife but the right-hand grip (4) has the recesses for the screwheads.

11-11. CLEANING.

11-12. Clean all parts of grease, oil, and dirt.

11-13. INSPECT AND REPAIR.

- a. Replace screws, if threads are stripped.
- b. Replace cracked grips or replace left-hand grip, if threads in grip are stripped.
- c. Replace spring pin, if worn or damaged.

d. Replace spring if, kinked, set, or broken.

e. Remove nicks and dents, as required, by grinding and/or stoning.

f. If wear is noted on the release camming area and positive retention to the rifle is questionable, replace as required. If binding is noted due to a bent release, repair by straightening or replace.

11-14. BAYONET-KNIFE SCABBARD, M8A1.

11-15. Metal parts will be dark. If finish of metal is worn, a rust inhibiting enamel or flat black lacquer may be applied to metal parts.

11-16. If the scabbard is chipped exposing the fabric or the surface is scratched or marred, smooth as required and paint with olive drab lusterless enamel.

11-17. Clean and/or replace broken or damaged restraining lace.

## CHAPTER XII

### LAUNCHER, GRENADE, 40-MM XM148

#### 12-1. GENERAL.

12-2. The XM148 grenade launcher (fig. 12-1) is a lightweight, single shot, manually operated device, used in conjunction with the M16 and XM16E1 rifles. It is designed to provide the user with an accurate device for launching 40-mm projectiles. It contains an adjustable sight assembly consisting of a front and rear sight provided with controls that have visual markings with click positioning, so that adjustment can be made in darkness, by sound or feel. The sight can also be set in various positions, enabling the operator to fire from any position.

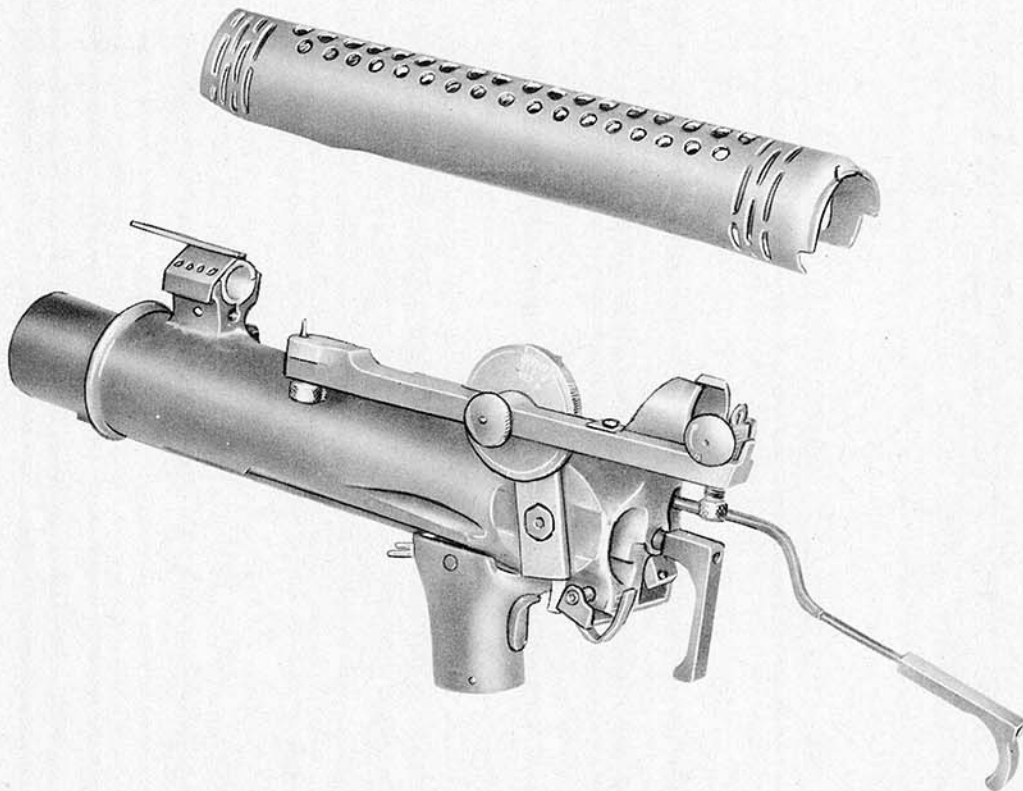

WE 13711

Figure 12-1. Grenade Launcher 40-MM XM148 - left rear view.

12-3. TABULATED DATA.

12-4. Tabulated data pertaining to the general characteristics and performance is listed as follows:

Launcher.

Length of launcher (front of barrel to rear of extended trigger) . . .	16-1/2 in.
Length of barrel . . . . .	10 in.
Weight of launcher:	
Loaded . . . . .	3.50 lbs (approx)
Unloaded . . . . .	3 lbs (approx)
Muzzle velocity . . . . .	74.5 meters/sec (247 fps)
Trigger Pull . . . . .	6 to 11 lbs

Operational characteristics:

- Single shot
- Manually operated
- Breech loaded

Ammunition.

Caliber . . . . .	40-mm
Type . . . . .	fixed
Length . . . . .	3.9 in.
Weight . . . . .	8.0 oz
Range (maximum) . . . . .	400 meters (437 yds)

**Note**

For detailed information on ammunition, refer to chapter V, section II.

12-5. SPECIAL TOOLS, EQUIPMENT AND REPAIR PARTS.

a. Special tools and equipment are tabulated in table 12-1 and are listed in chapter IX of this manual. This tabulation contains only those tools utilized in performing the operations described in this manual.

b. Basic issue items and repair parts are listed in chapter IX of this manual.

12-6. PREPARATION FOR USE, STORAGE, AND SHIPMENT.

12-7. Refer to chapter II.

12-8. INSTALLATION AND REMOVAL.

**Note**

White arrows indicate removal of components and black arrows indicate installation with exception of pages 12-5 and 12-6, where white arrows indicate installation and black removal.

TABLE 12-1. SPECIAL TOOLS AND EQUIPMENT

Item	Identifying Number	Reference Fig.	Use
BRUSH, CLEANING:	7790665	12-2 and 12-8	To clean barrel bore.
BRUSH, CLEANING SMALL ARMS:	6108828	12-2 and 12-7	To clean firing pin recess.
CASE, CARRYING, SIGHT:	2-2-248	12-2	To carry sight assembly.
TOOL, COMBINATION:	8430382	12-2 and 12-11, step 20	To install, remove, disassemble and assemble launcher.
THONG, CLEANING BRUSH:	7790631	12-2 and 12-8	Used with cleaning brush 7790665 to clean barrel.
WRENCH ASSEMBLY, HEXAGON SOCKET:	56306	12-2 and 12-10 step 7 and 12-11, step 18	To remove/install sight slide and disassemble and assemble sight assembly.
WRENCH, 7/16 OPEN END:	56258	12-2 and 12-10 step 7 and 12-11, step 18	To remove/install sight slide and to disassemble and assemble sight assembly.

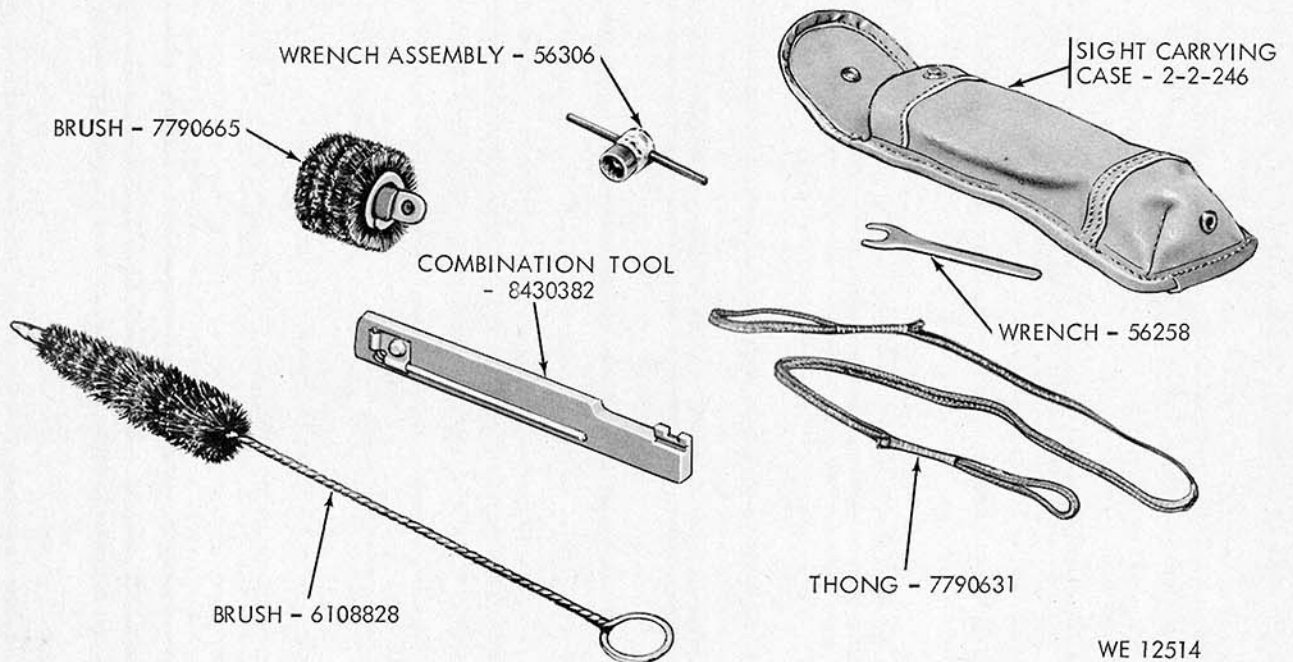
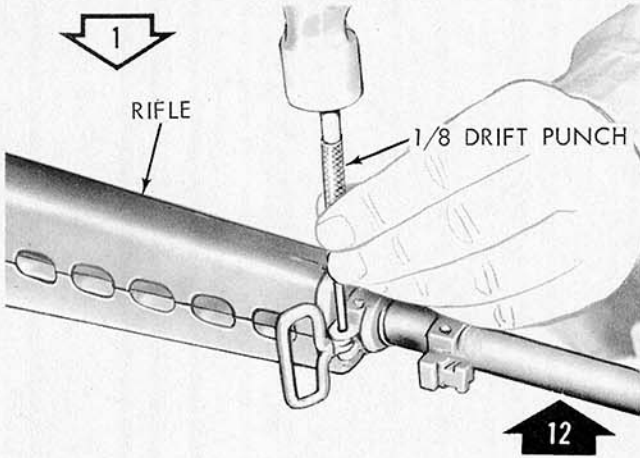

Figure 12-2. Special Tools and Equipment.

**Note**

Steps 1, 2 and 3 are authorized for Organizational level. Steps 4 through 13 are authorized the operator.

12-9. Refer to figure 12-3.



Remove/install front swivel pin.

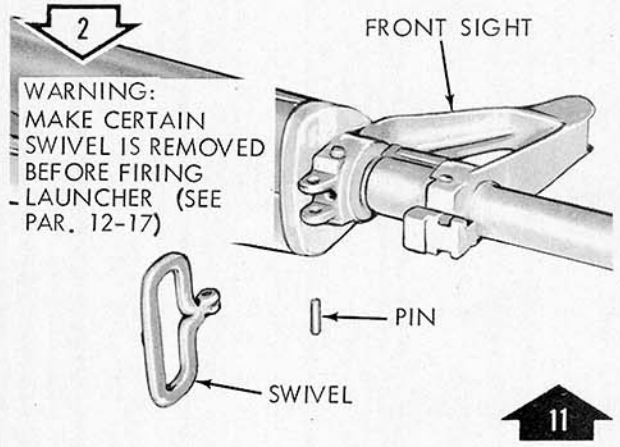

Remove/install gun sling swivel.

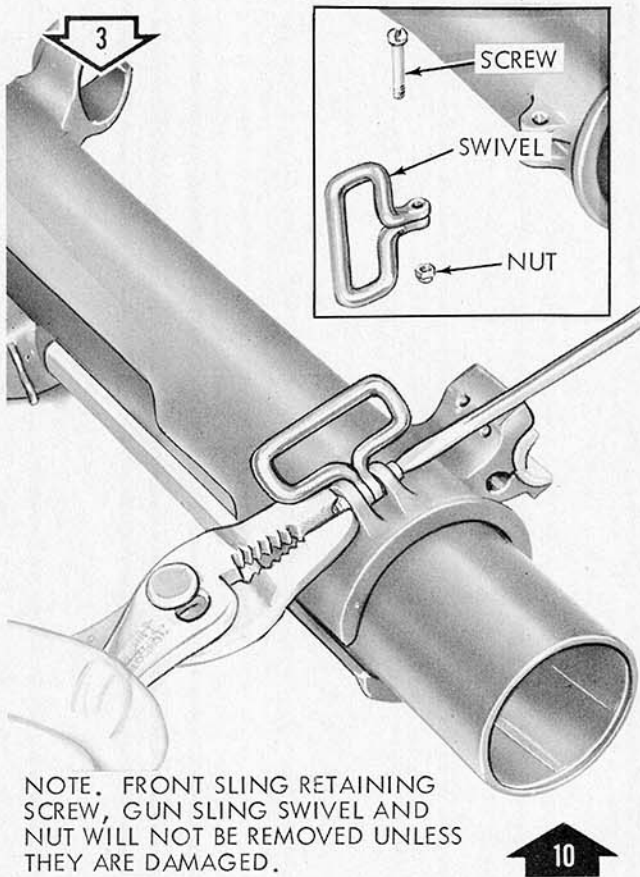

NOTE. FRONT SLING RETAINING SCREW, GUN SLING SWIVEL AND NUT WILL NOT BE REMOVED UNLESS THEY ARE DAMAGED.

Remove/Install front sling retaining screw, gun sling swivel and nut, to/from launcher housing.

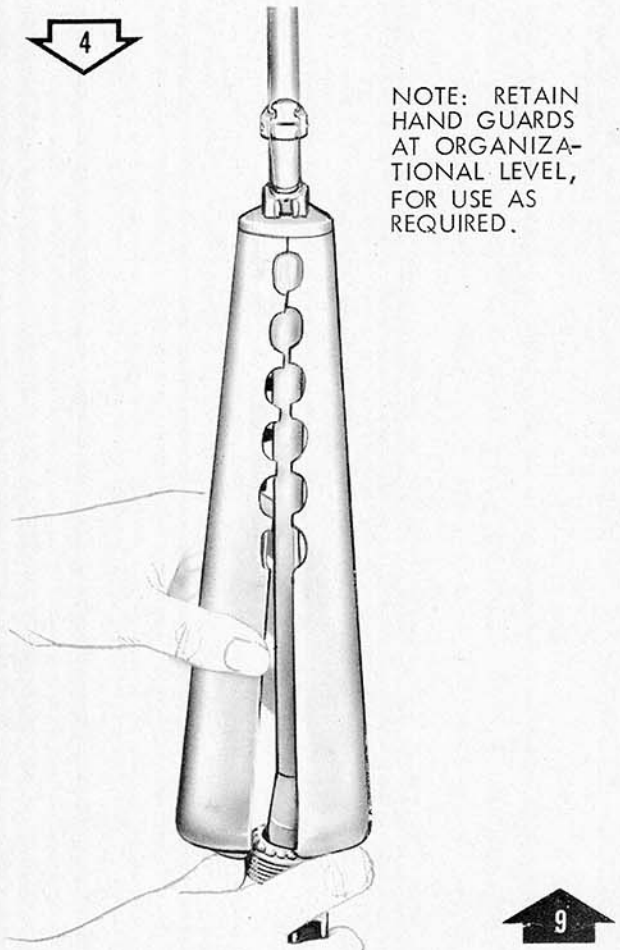

Remove/install hand guards.

WE 10461

Figure 12-3. Installation and Removal of Grenade Launcher. (Page 1 of 3).

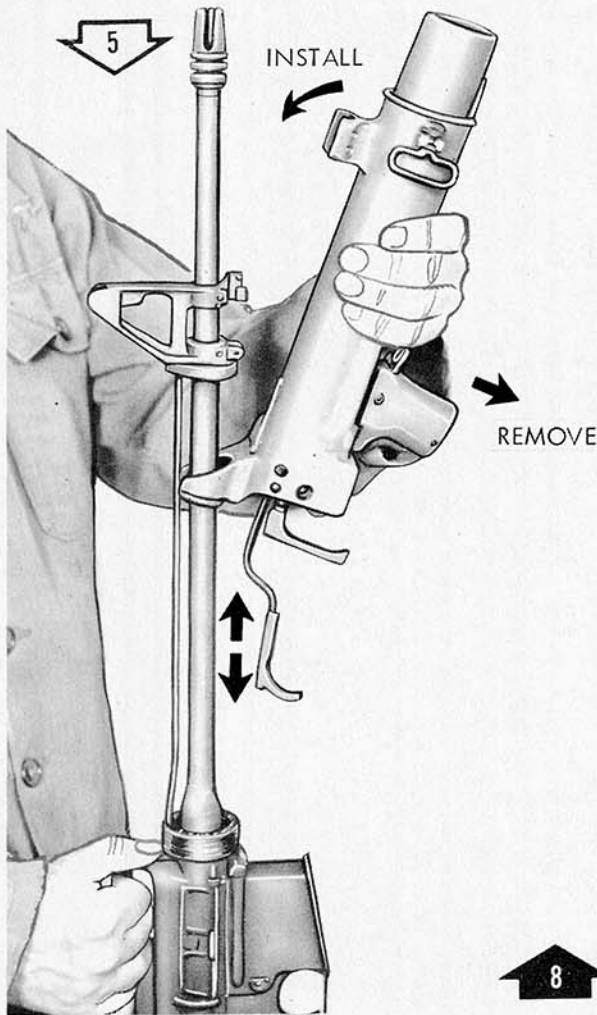

Install/remove grenade launcher.

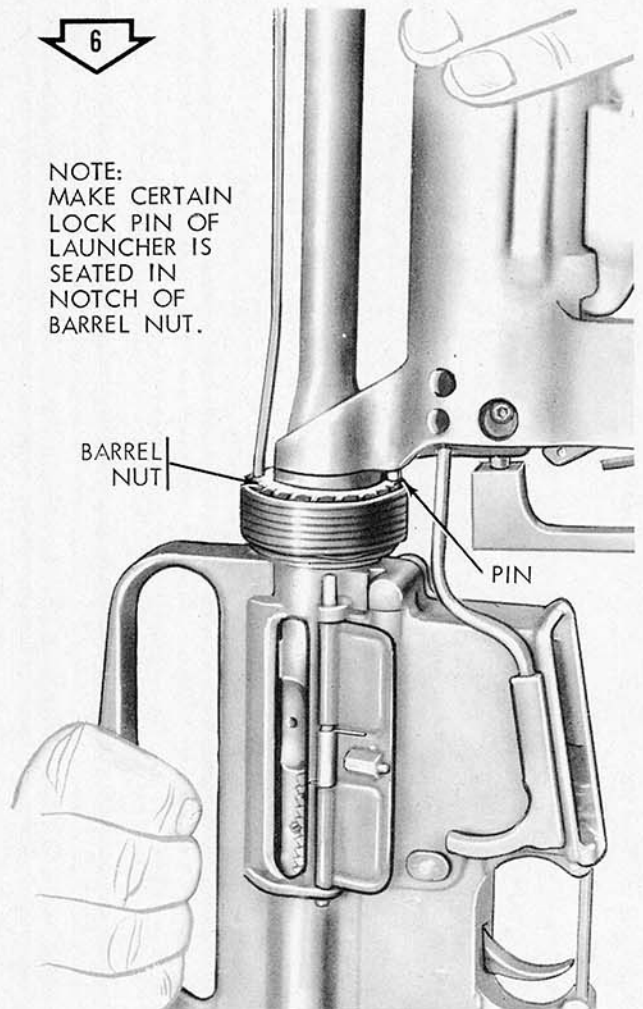

Grenade launcher seated.

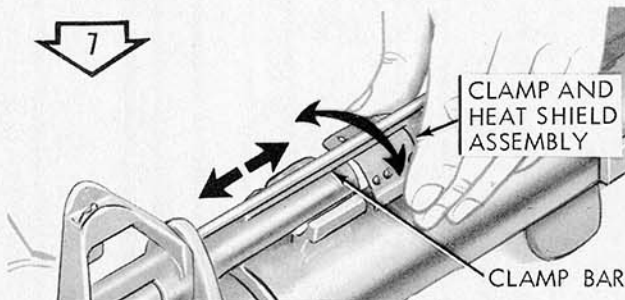

Note: During initial installation, if the holes in the clamp and heat shield assembly do not align with holes in front mount, file off minimum amount of front portion of clamp bar until holes are aligned.

Install/remove clamp and heat shield assembly.

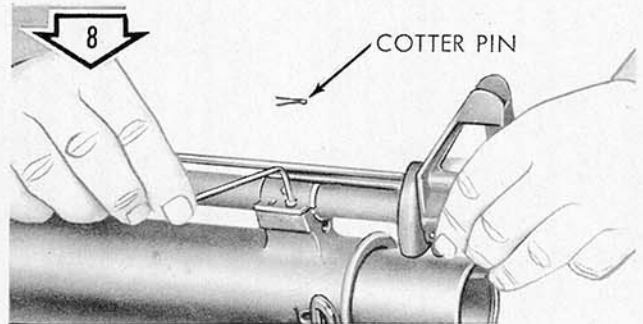

CAUTION: When tightening screws, do not close gap between clamp and housing. Tighten screws until snug, then align holes and install cotter pin. Spread ends of cotter pin to prevent loss.

Install/remove cotter pin and front mount cap screws.

WE 12503

Figure 12-3. Installation and Removal of Grenade Launcher. (Page 2 of 3).

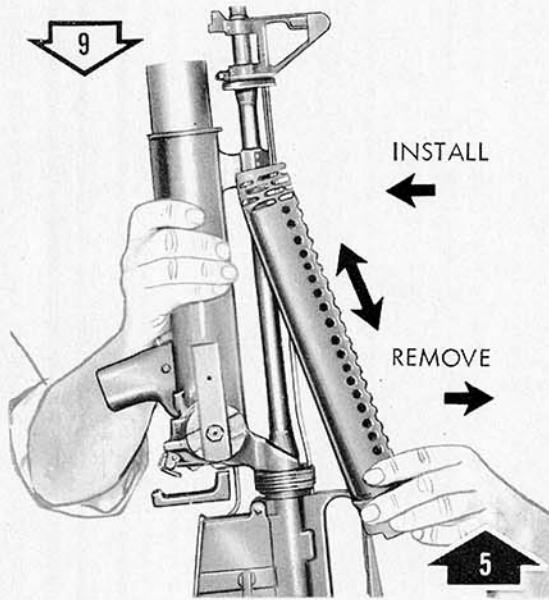

Install/remove hand guard.

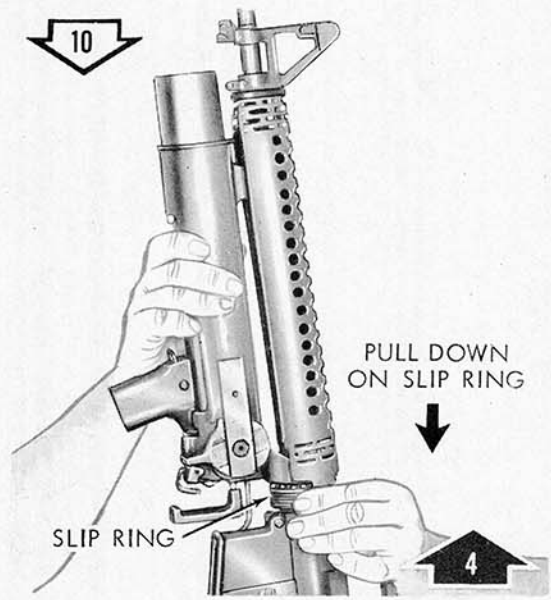

Engage/disengage slip ring.

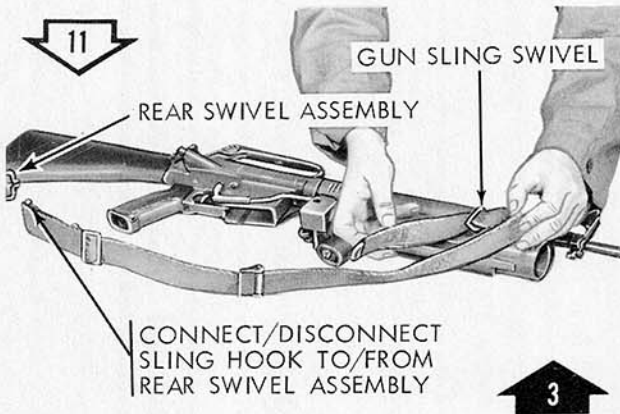

Install/Remove sling.

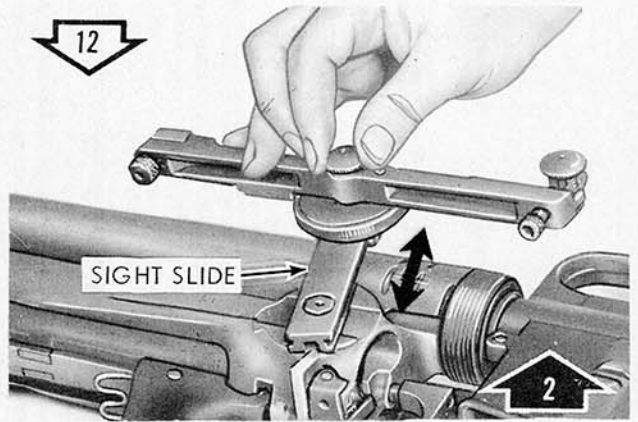

Install/remove sight assembly.

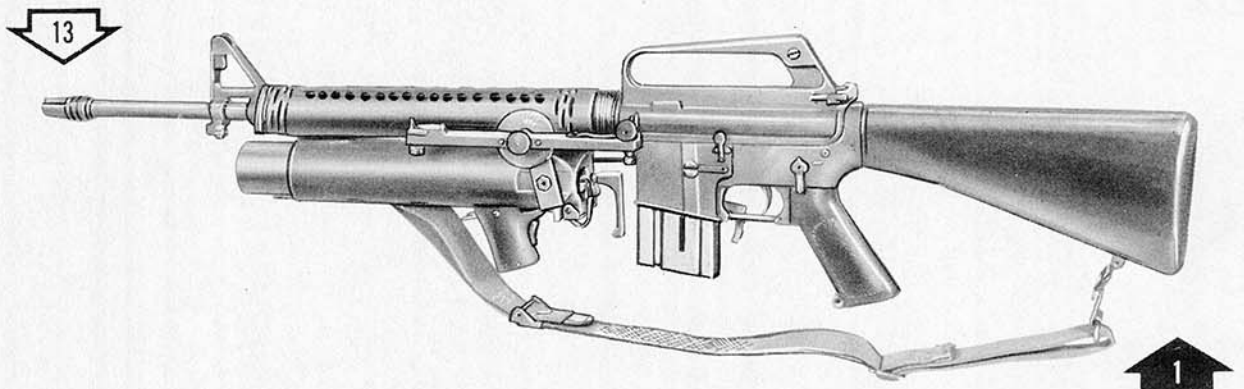

Grenade launcher installed on rifle.

WE 12504

Figure 12-3. Installation and Removal of Grenade Launcher. (Page 3 of 3).

## 12-10. OPERATING INSTRUCTIONS.

a. Clear the grenade launcher by performing the operation as indicated in figure 12-4.

b. Refer to figure 12-5 for controls.

## 12-11. CLEANING BEFORE FIRING.

12-12. The barrel bore and chamber should be wiped dry before firing.

## 12-13. SERVICE BEFORE FIRING.

12-14. Perform the "before firing" operations as described in the operations preventive services, table 12-2.

## 12-15. LOADING.

12-16. Load the grenade launcher as indicated in figure 12-6.

## 12-17. FIRING.

### WARNING

Do not fire launcher with front sling swivel or bayonet on the rifle.

- Move safety to safe position (see fig. 12-5).
- Extend trigger (see fig. 12-5).

### CAUTION

Make certain trigger is extended before cocking the launcher.

- Retract cocking lever to cock position.
- Check target area and adjust sights. Refer to TC 23-10
- Load (see fig. 12-6).

### WARNING

When the safety is in fire position, avoid striking or bumping the rifle or launcher as the launcher may discharge.

- Move safety to fire position, (see fig. 12-5), sight in target, squeeze trigger to fire.

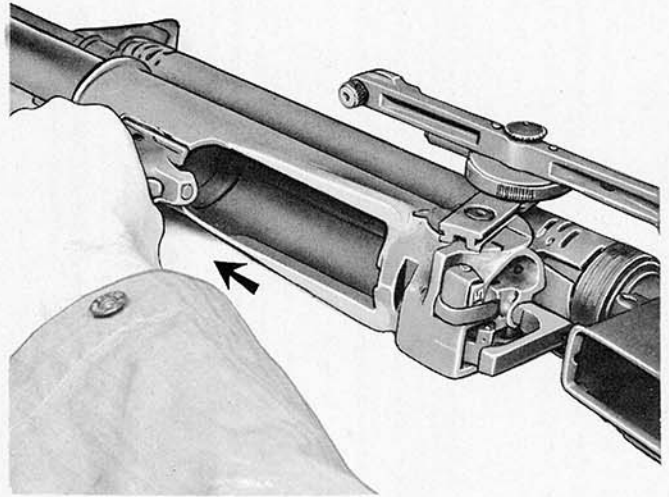

Figure 12-4. Clearing the grenade launcher.

### WARNING

For range firing or training purposes, the rifle will not be loaded. In tactical situations, when the rifle is loaded, the rifle selector lever will be in the "SAFE" position to prevent inadvertent fire during grenade launching. Rifle bullets could detonate grenade projectiles in flight with resultant hazard to firer or other personnel.

## 12-18. MISFIRE AND HANGFIRE.

12-19. Misfire. A misfire is a complete failure to fire which may be due to a faulty mechanism or a faulty element in the propelling charge of the round. A misfire in itself is not dangerous, but since it cannot be immediately distinguished from a hangfire, or a delay in functioning of the firing pin, it must be treated as a hangfire until such possibility has been eliminated.

12-20. Hangfire. A hangfire is a delay in the functioning of a propelling charge explosive train at the time of firing. The amount of delay is unpredictable but in most cases will fall within the range of a split second to several seconds. Thus, a hangfire cannot be distinguished immediately from a misfire and the rein lies the principal danger of assuming that a failure of the weapon to

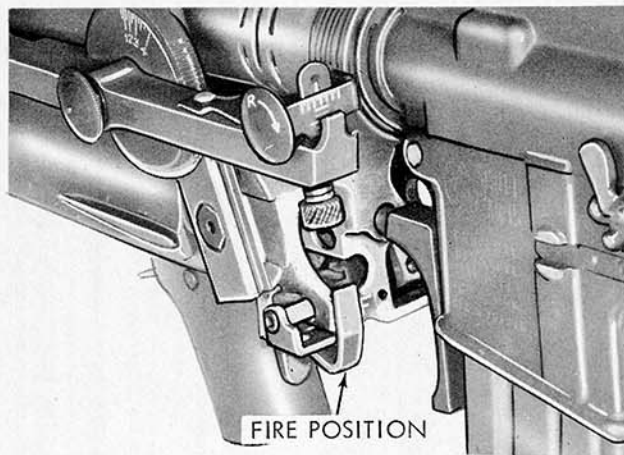
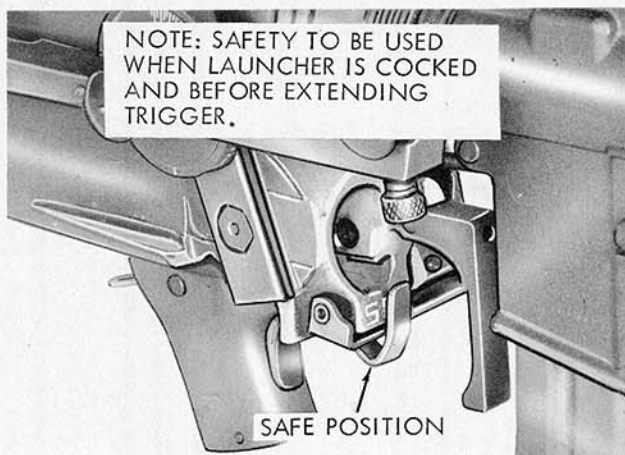

A - Safety

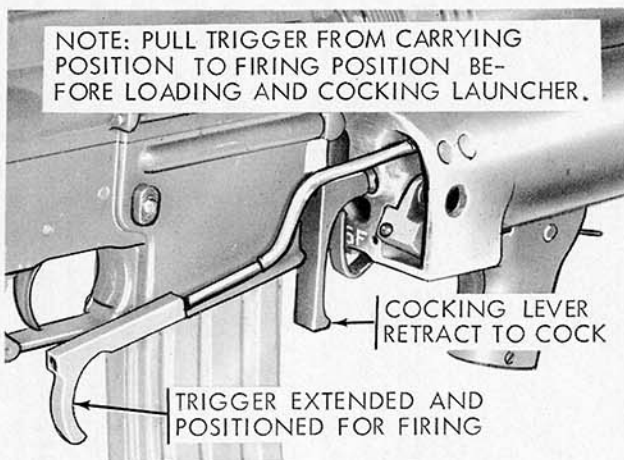
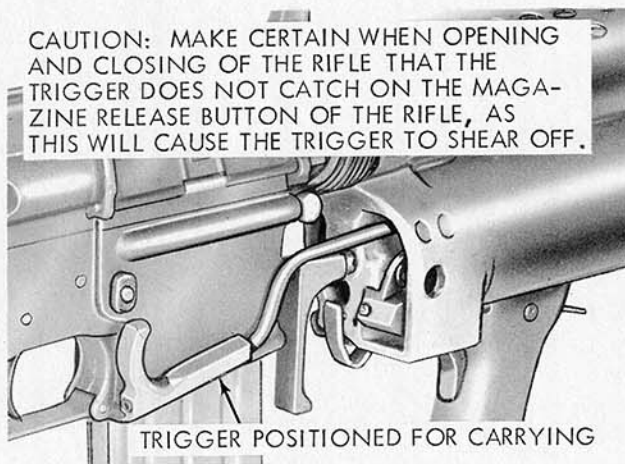

B - Trigger and Cocking Lever

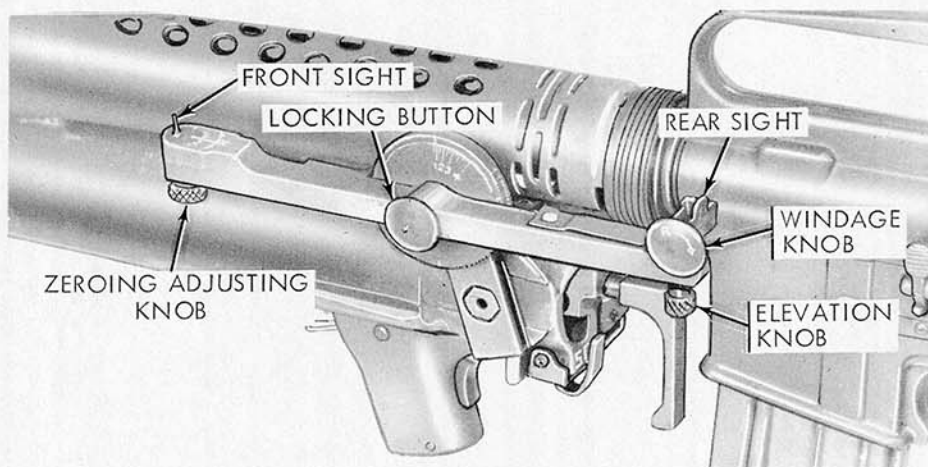

C - Sight

WE 13761

Figure 12-5. Controls.

**WARNING: LAUNCHER SHOULD NOT BE COCKED PRIOR TO LOADING.**

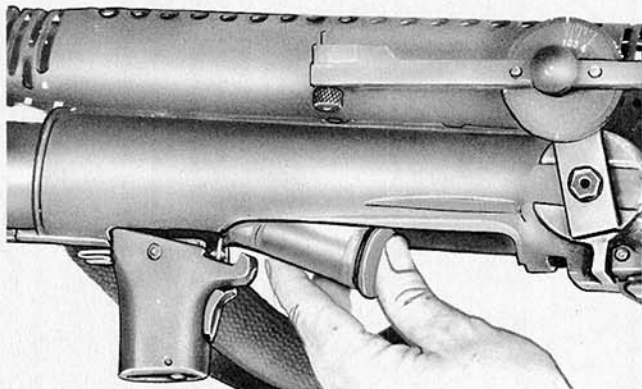

**NOTE: INSERT ROUND FULLY IN CHAMBER, TO ENGAGE CARTRIDGE RETAINER. RETRACT PISTOL GROUP AND BARREL, REARWARD TO LOCKED POSITION.**

WE 12523

Figure 12-6. Loading.

fire immediately upon actuating of the firing pin is a misfire, whereas in fact it may prove to be a hangfire.

12-21. Failure to Fire. After a failure to fire, recock and attempt to fire. If launcher again fails to fire this is due to the possibility of a misfire or hangfire and the following precautions are applicable and will be observed until the round has been removed from the weapon and the cause of failure determined.

a. Keep the weapon trained on the target and all personnel clear of the muzzle.

b. Wait 30 seconds from the time of failure of the weapon to fire before opening the breech, to remove the round.

**WARNING**

During the prescribed time interval, the weapon will be kept trained on the target and all personnel will stand clear of the muzzle.

c. Before attempting to remove the round from the launcher, personnel not required for the operation will be cleared from the vicinity.

d. Make certain the round, removed from the launcher, is kept separate from the other rounds until it has been determined whether the round was at fault. If the launcher is determined to be at fault, the round may be reloaded and fired after the launcher is repaired.

12-22. UNLOADING.

12-23. Unload the grenade launcher as shown in figure 12-9.

12-24. CLEANING AND LUBRICATION AFTER FIRING.

**WARNING**

Make certain rifle and launcher are unloaded and safe prior to cleaning and lubrication.

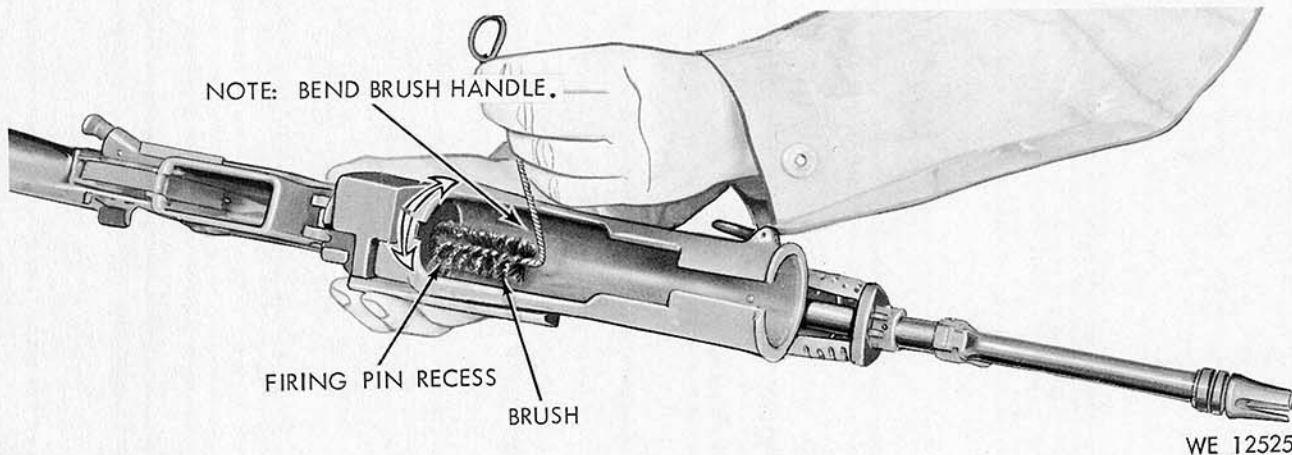

WE 12525

Figure 12-7. Cleaning Firing Pin Recess.

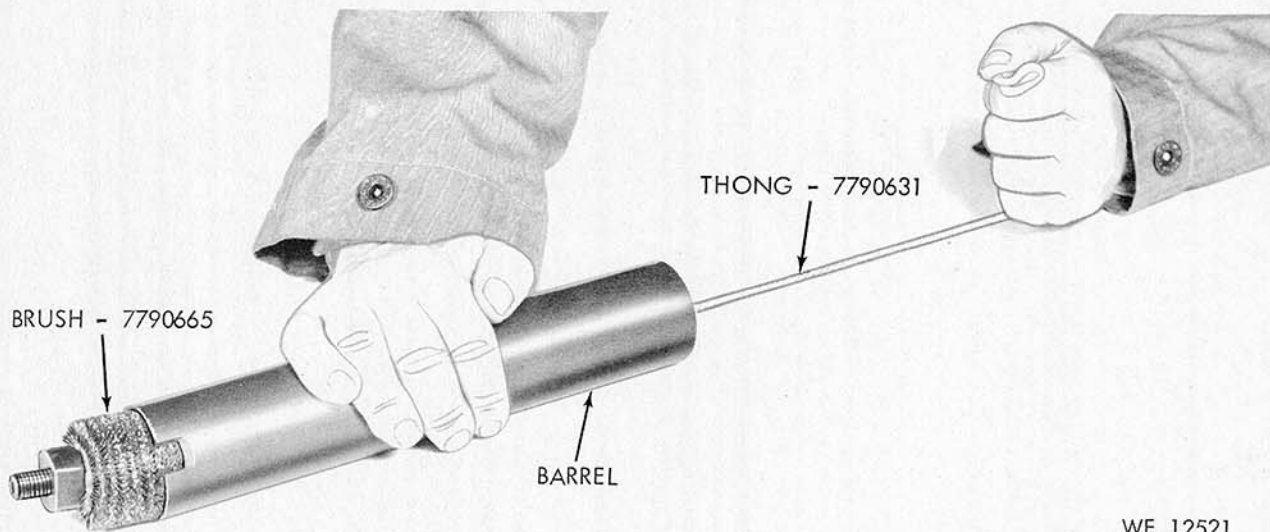

Figure 12-8. Cleaning Barrel Bore.

a. Remove firing pin as shown in steps 20 and 21 of figure 12-11.

b. Clean firing pin recess as shown in figure 12-7, also firing pin, buffer spring, firing pin spring, and firing pin retainer with solvent cleaning compound (CR), then wipe dry and apply a light coat of general purpose lubricating oil (PL special).

**CAUTION**

When cleaning barrel bore make no attempt to remove minor coppering.

c. Clean the bore of the barrel with cleaning brush (fig. 12-8) and solvent cleaning compound (CR), making certain all surfaces are well coated, then wipe dry and apply a light coat of general purpose lubricating oil (PL special).

d. Clean exterior surfaces of sight assembly, pistol grip group, barrel group, trigger group and housing assembly, using dry cleaning solvent (SD). Wipe dry and apply a light coat of general purpose lubricating oil (PL special).

NOTE: WHILE UNLOADING, BARREL SHOULD BE HELD IN HORIZONTAL POSITION TO ALLOW EMPTY CASE TO DROP FREE.

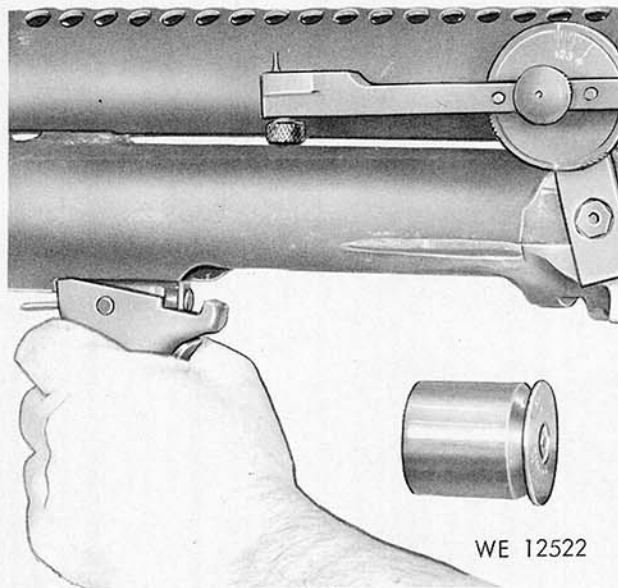

Figure 12-9. Unloading.

12-25. PREVENTIVE MAINTENANCE.

12-26. Refer to table 12-2 for procedures to be performed on the launcher by the operator for each daily service.

TABLE 12-2. PREVENTIVE MAINTENANCE CHECKS AND SERVICES

Interval & Sequence No.			Operator	Daily Schedule	
Before firing	During firing	After firing		Item to be inspected	Procedures
*1			Rifle and Launcher	Check grenade launcher for positive retention to rifle.	Fig. 12-3.
*2			Sight Assembly	Check adjustments for retention.	Fig. 12-5.
3			Grenade Launcher	Wipe oil from barrel bore and chamber.	Paragraph 12-12.
*4			Grenade Launcher	Hand function to assure proper operation of barrel and pistol grip group.	Paragraph 12-17.
5			Grenade Launcher	Trigger should be in firing position.	Fig. 12-5.
*6			Grenade Launcher	Check functioning of safety in safe and fire positions.	Paragraph 12-17.
		*7	Grenade Launcher	Clean and lubricate. Make certain to clean exterior of barrel and interior of housing.	Paragraph 12-22.

\*Indicates checks and services will be performed weekly, if the daily schedule is not otherwise performed as the result of firing.

12-27. AMMUNITION.

12-28. Refer to chapter V, section II.

12-29. DESTRUCTION OF MATERIAL TO PREVENT ENEMY USE.

12-30. Refer to chapter VI, section II.

12-31. TROUBLE SHOOTING.

12-32. Refer to table 12-3 for trouble shooting.

12-33. DISASSEMBLY AND ASSEMBLY.

**WARNING**

Insure launcher and rifle are unloaded and safe, prior to disassembly or assembly.

**Note**

The white arrows in the upper left-hand corner of illustration gives the sequence of disassembly and the black arrows in the lower right hand corner of the illustration gives the sequence of assembly.

a. Disassembly and assembly of the grenade launcher for Operator and Organizational maintenance is as follows:

TABLE 12-3. TROUBLE SHOOTING

Malfunction	Probable cause	Remedy
Fails to cock.	Dirty or damaged trigger spring.	Clean or replace.
Fails to fire.	Dirty and/or residue in firing pin recess.	Clean. Refer to fig. 12-7.
	Broken firing pin.	Replace.
	Weak or broken firing pin spring.	Replace.
	Burred firing pin or sear.	Remove burs.
	Faulty ammunition.	Replace.
	Improperly installed, deformed or broken buffer spring.	Replace.
Fails to extract.	Extractor, bent, broken or loose.	Tighten screw if loose and replace if bent or broken.
	Ruptured cartridge case stuck in barrel.	Remove case with cleaning rod inserted through muzzle of barrel.
Sight changes in range elevation setting, when launcher is fired.	Range adjustment too loose on sight assembly.	Tighten friction bolt. Refer to step 7, fig. 12-10.
Sight range adjustment or change cannot be made.	Range adjustment too tight on sight assembly.	Loosen friction bolt. Refer to step 7, fig. 12-10.

- (1) Remove sight assembly as shown in step 2, black arrow of figure 12-3.
- (2) Disconnect sling as shown in step 3, black arrow of figure 12-3.
- (3) Disassembly and assembly of the launcher is shown in figure 12-10.

**Note**

Steps 1 through 3, white arrows, are authorized the operator for normal care and cleaning and steps 4 through 11, for care and cleaning when the weapon accumulates foreign matter, which would probably cause malfunction.

b. Disassembly and assembly of the grenade launcher for Direct and General Support Maintenance is shown in figures 12-11 and 12-11A.

**CAUTION**

The grenade launcher should not be subjected to white glove type inspections for the following reasons:

(1) A slight residue of foreign matter in the hard to reach places will not cause malfunctions.

(2) Repeated disassembly of aluminum components will cause excessive wear resulting in reduced functional reliability and shorten the life of the weapon. For the forgoing reasons, steps 4 through 11 will be performed only when absolutely necessary. This restriction should be taken into consideration during inspection of the grenade launcher in hands of the troops.

NOTE: STEPS 1 THROUGH 3 (WHITE ARROWS), AND STEPS 14 THROUGH 16 (BLACK ARROWS), ARE NORMALLY PERFORMED WHEN THE LAUNCHER IS ON THE RIFLE.

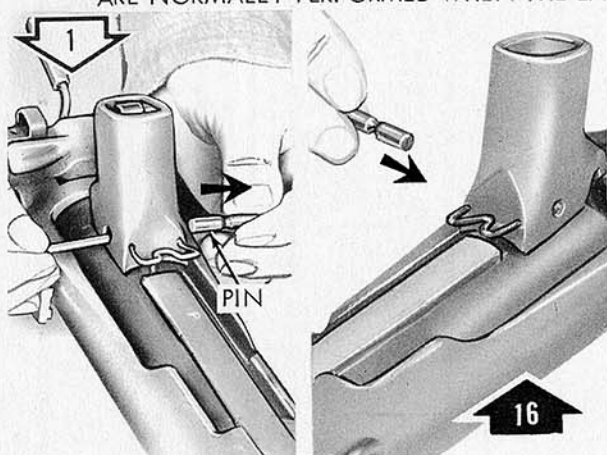

Remove/Install pivot pin.

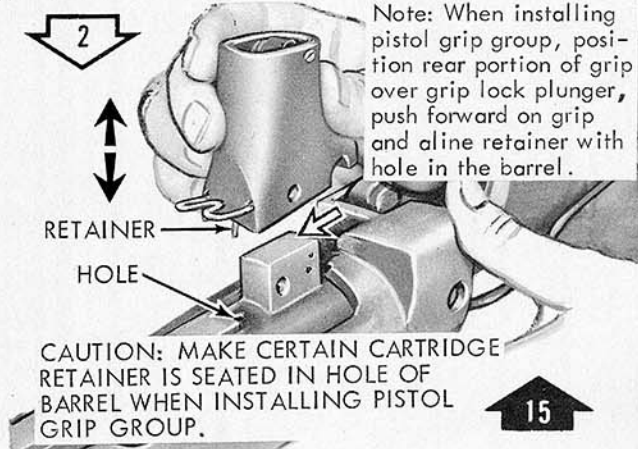

Remove/Install pistol grip group.

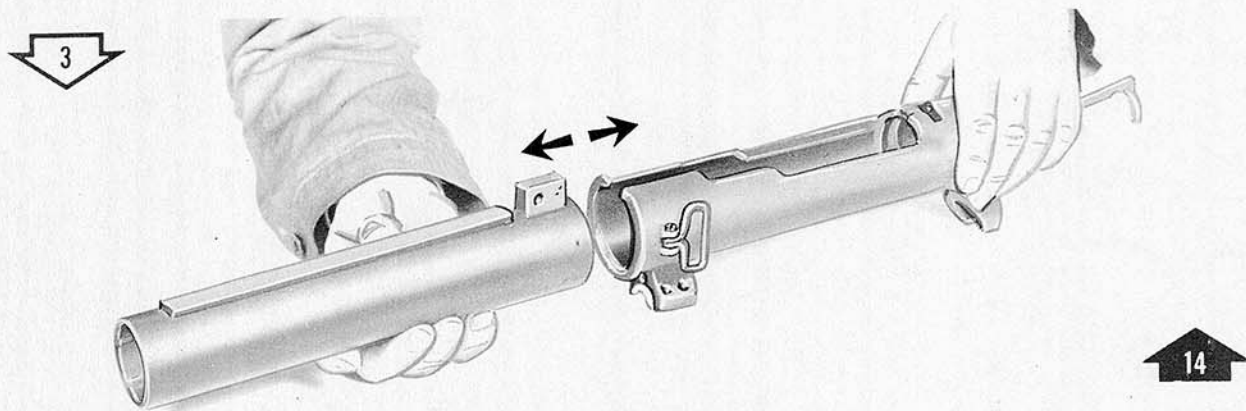

Remove/Install barrel group.

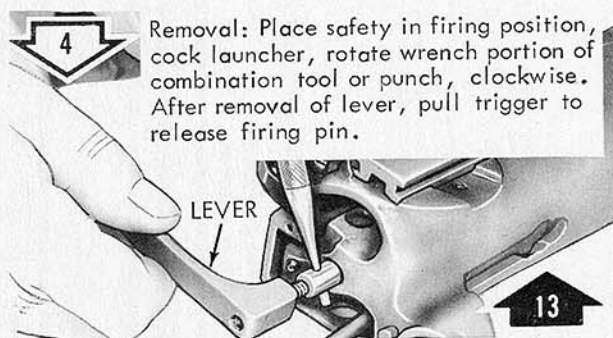

Removal: Place safety in firing position, cock launcher, rotate wrench portion of combination tool or punch, clockwise. After removal of lever, pull trigger to release firing pin.

Installation: Place safety in firing position, depress sear lever, pull firing pin rearward, insert allen wrench or drift punch in hole of firing pin. Cock launcher using allen wrench or drift punch as a handle. Turn firing pin counter-clockwise with allen wrench or drift punch to install cocking pin on firing pin.

Remove/Install cocking lever.

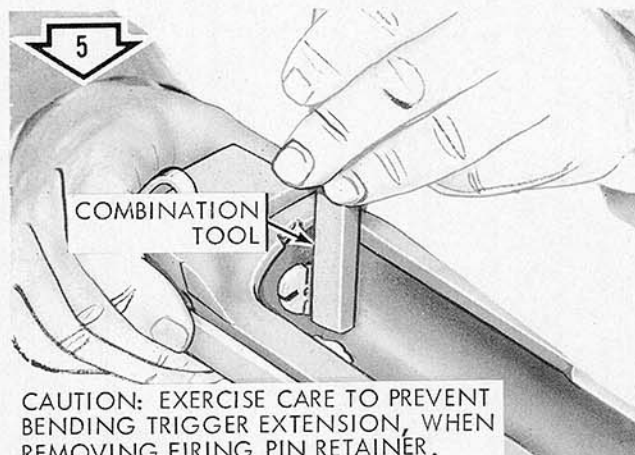

Remove firing pin retainer.

WE 13670

Figure 12-10. Disassembly/Assembly of Grenade Launcher (Operator and Organizational Maintenance)  
(Page 1 of 3)

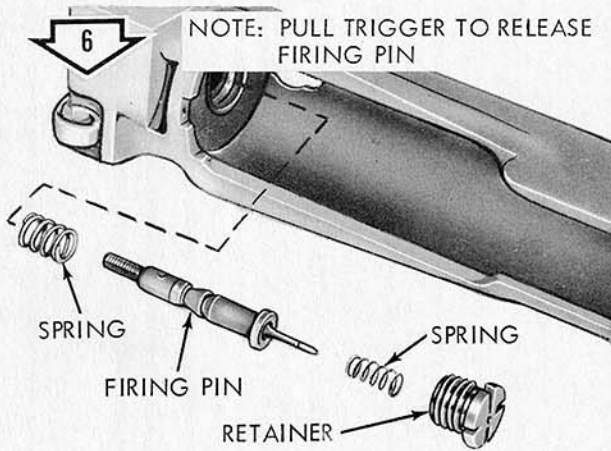

Remove buffer spring, firing pin and spring.

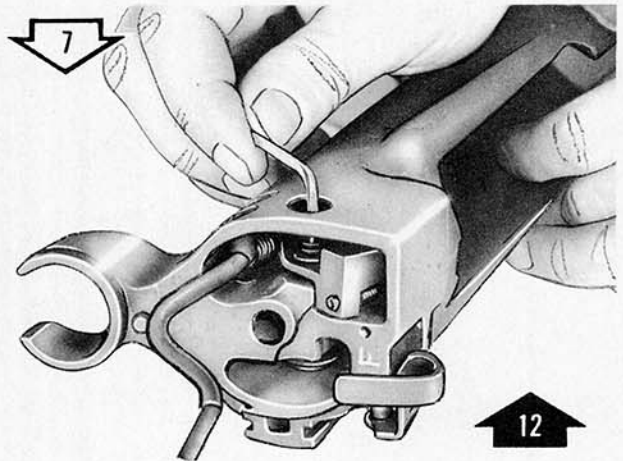

Remove/Install sear lever screw and washer.

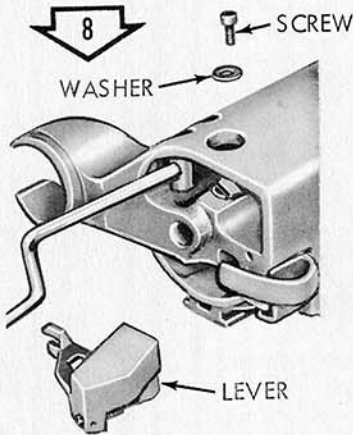

Remove sear lever.

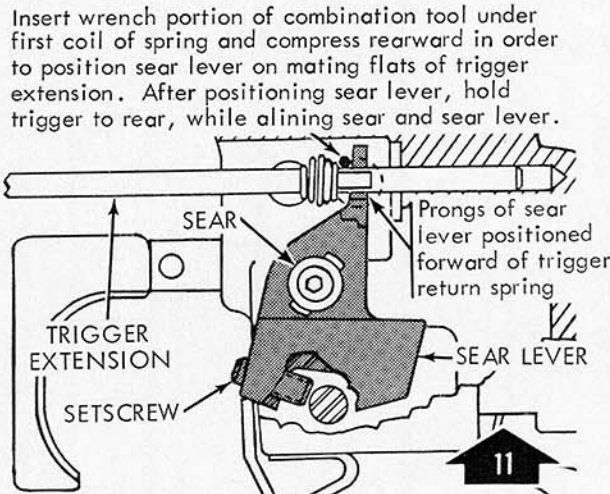

Proper position of sear lever.

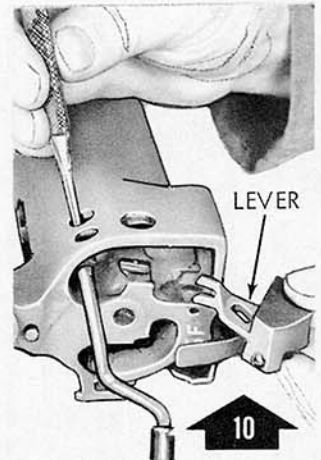

Install sear lever.

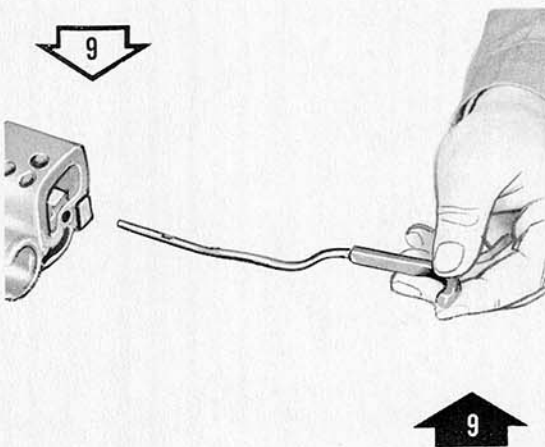

Remove/Install trigger group.

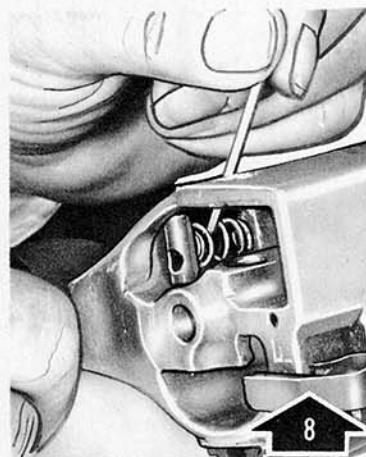

Positioning helical compression spring.

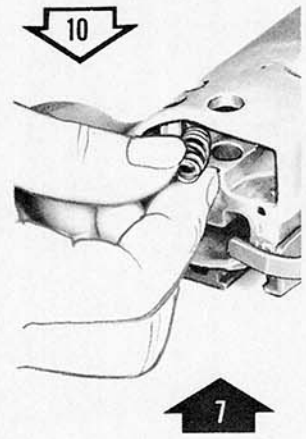

Remove/Install helical compression spring.  
WE 13809

Figure 12-10. Disassembly/Assembly of Grenade Launcher (Operator and Organizational Maintenance)  
(Page 2 of 3)

Change 6, 1 May 1966

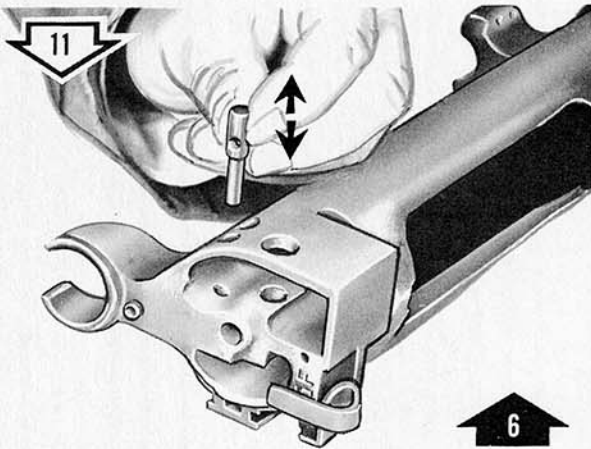

Remove/Install trigger extension support.

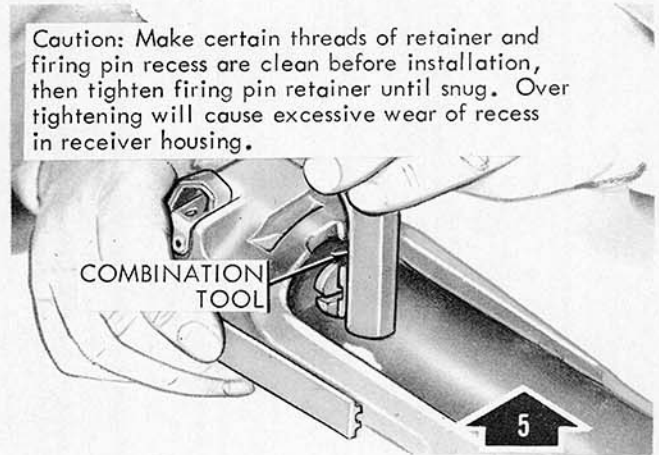

Caution: Make certain threads of retainer and firing pin recess are clean before installation, then tighten firing pin retainer until snug. Over tightening will cause excessive wear of recess in receiver housing.

Install firing pin retainer.

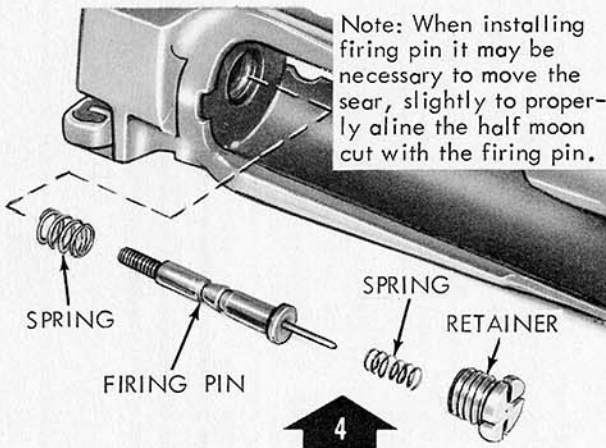

Install buffer spring, firing pin and spring.

NOTE: THE FOLLOWING STEPS WILL BE PERFORMED ONLY WHEN THE LAUNCHER IS REMOVED AS INDICATED IN STEPS 1 THROUGH 8 (BLACK ARROWS) FIGURE 12-3; FOR INSTALLATION STEPS 5 THROUGH 13 (WHITE ARROWS).

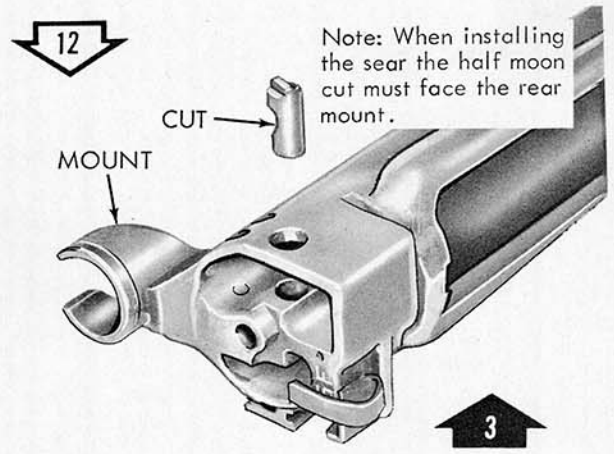

Remove/Install sear.

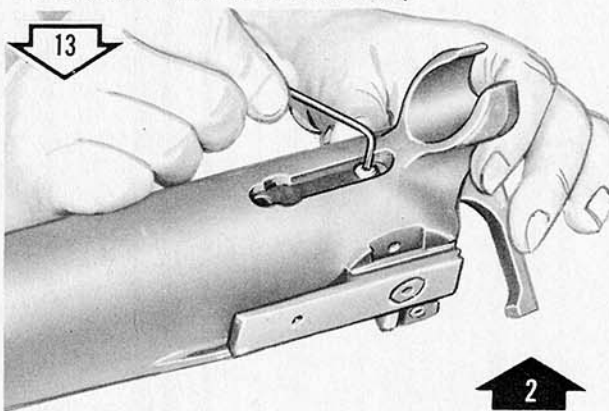

Remove/Install extractor screw.

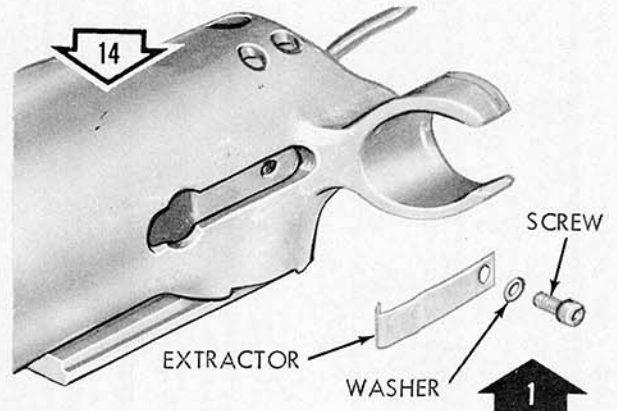

Remove/Install extractor and washer.

WE 13669

Figure 12-10. Disassembly/Assembly of Grenade Launcher (Operator and Organizational Maintenance).  
 (Page 3 of 3)

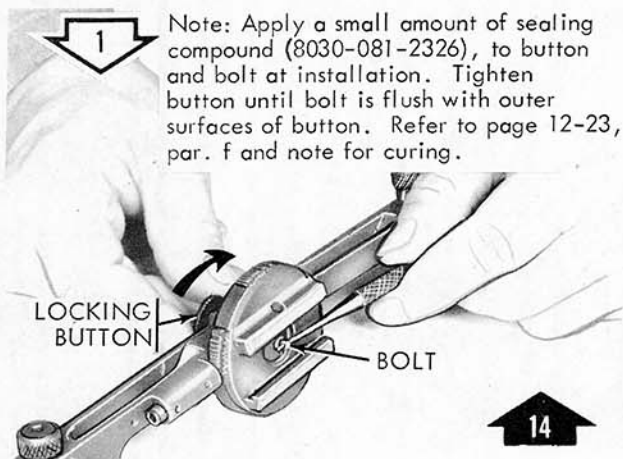

Remove/install locking button.

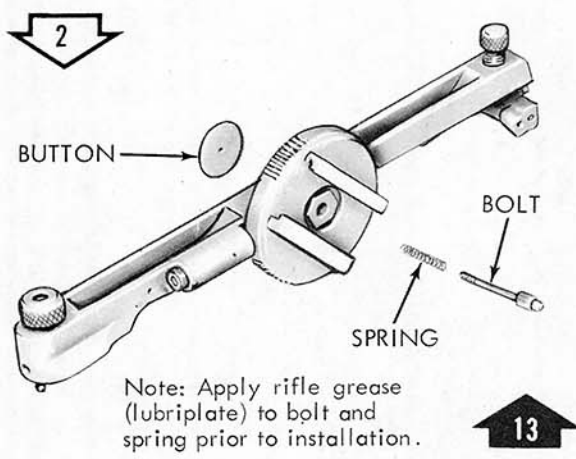

Remove/install locking bolt and spring.

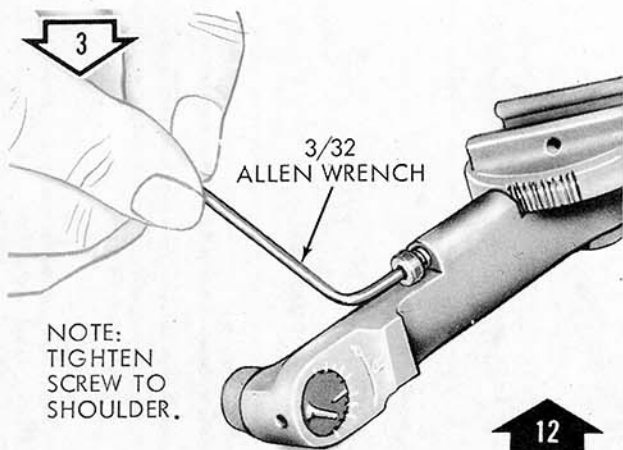

Remove/install elevating detent adjusting screw.

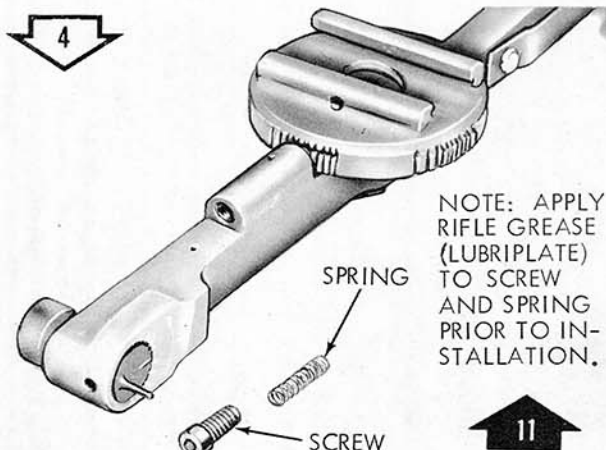

Remove/install helical compression spring.

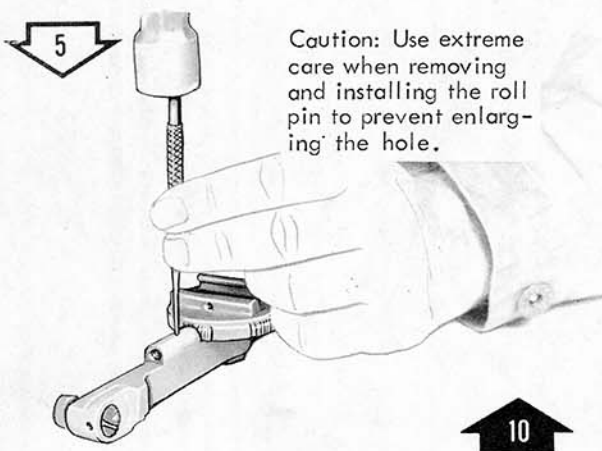

Remove/install roll pin.

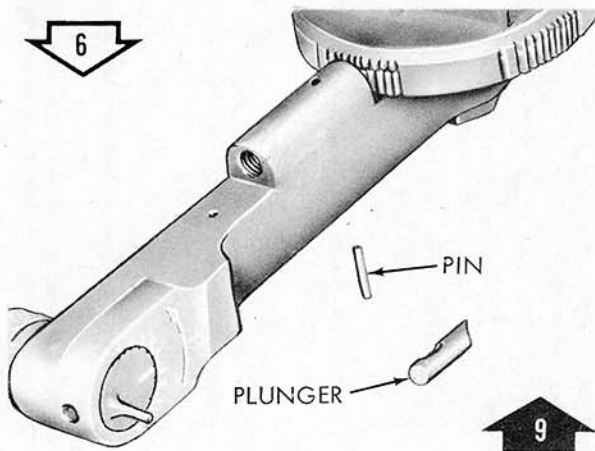

Remove/install detent plunger.

WE 12505

Figure 12-11. Disassembly/Assembly of Sight Assembly. (Direct and General Support Maintenance) (Page 1 of 3).

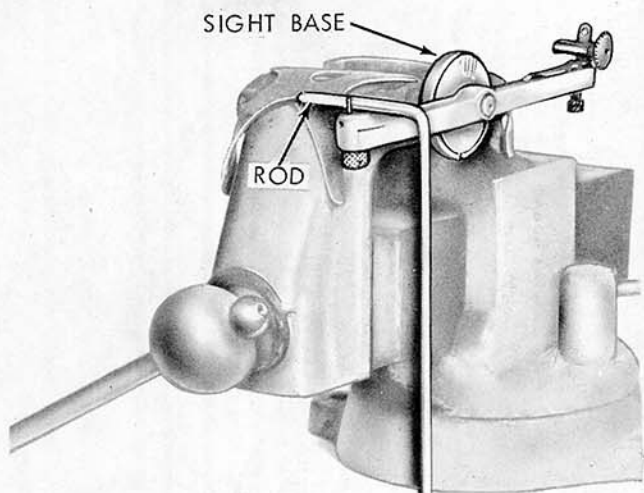

NOTE: SECURE SIGHT BASE GUIDES IN JAWS OF VISE WITH TENSION SPRING IN DOWNWARD POSITION, POSITION ROD CLOSE TO FRONT SIGHT.

NOTE: THIS FRICTION SETTING IS MADE WITHOUT THE DETENT ENGAGED IN SIGHT BASE. SIGHT SHOULD NOT TURN WITH 8 LBS. WILL TURN WITH ANYTHING IN EXCESS OF 9 LBS.

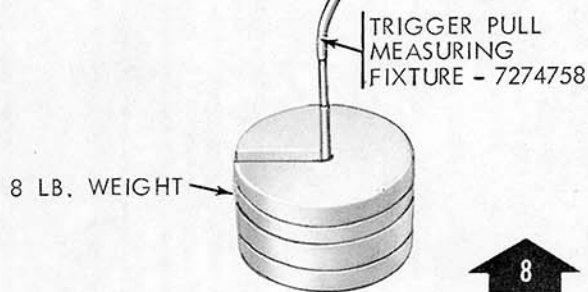

Checking sight for friction setting.

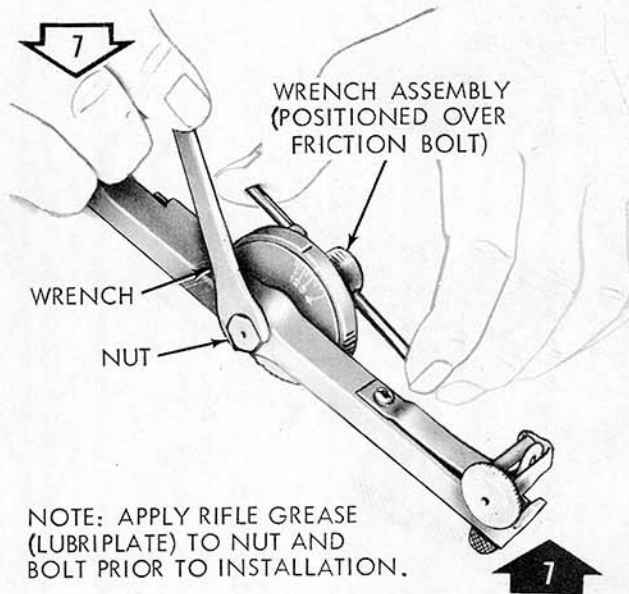

NOTE: APPLY RIFLE GREASE (LUBRIPLATE) TO NUT AND BOLT PRIOR TO INSTALLATION.

Remove/install friction nut and bolt.

NOTE: FRICTION SURFACES OF SIGHT BASE AND DISK MUST BE COMPLETELY DRY AT INSTALLATION.

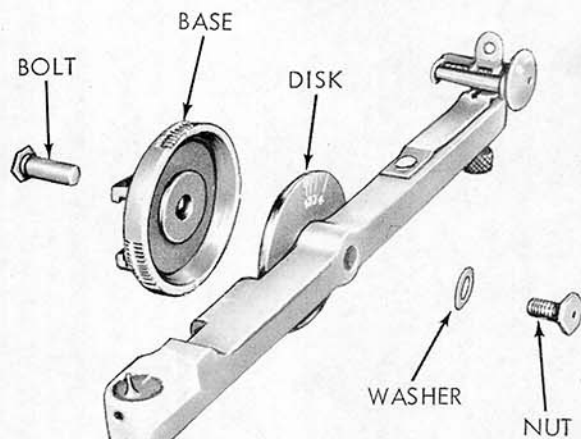

Note: Apply a small amount of sealing compound (8030-081-2326) to threaded area of nut at installation. Refer to page 12-23, par. f and note for curing.

Remove/install spring washer and sight base.

WE 12506

Figure 12-11. Disassembly/Assembly of Sight Assembly. (Direct and General Support Maintenance)  
 (Page 2 of 3).

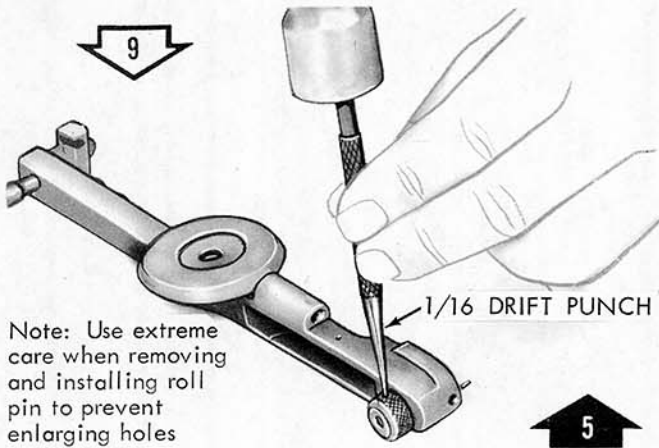

Note: Use extreme care when removing and installing roll pin to prevent enlarging holes

Remove/install roll pin.

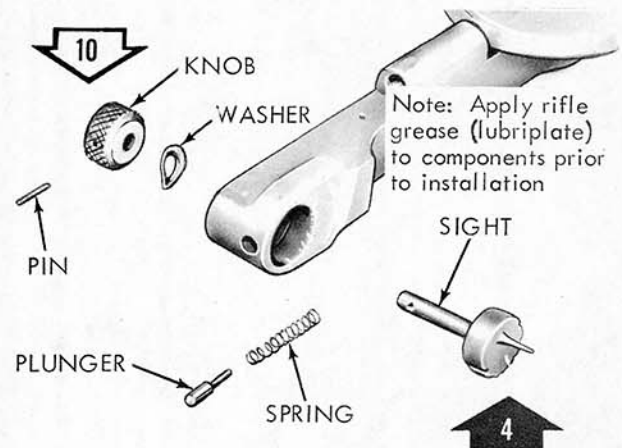

Remove/install front sight knob, spring tension washer, front sight, detent plunger and spring.

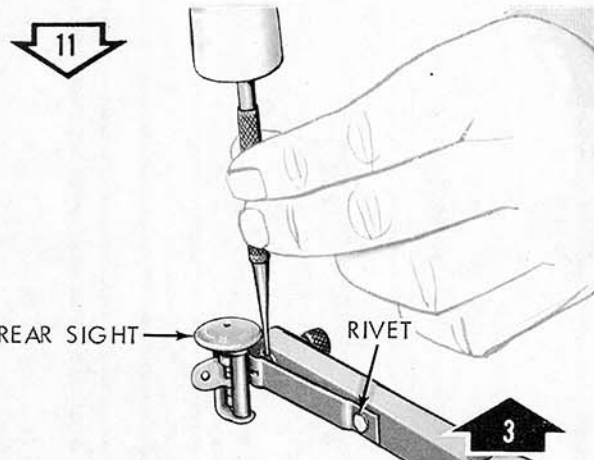

Remove/install roll pin.

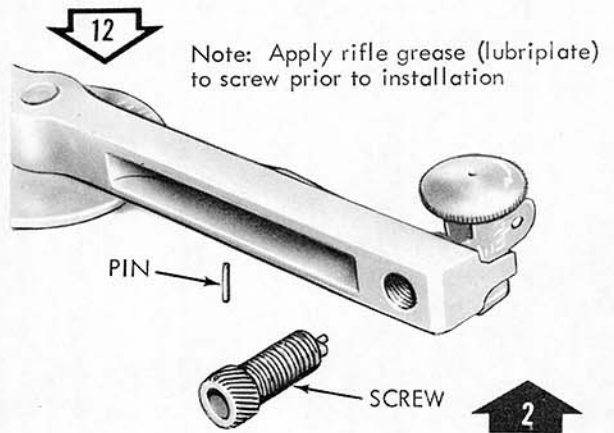

Remove/install elevating adjusting screw.

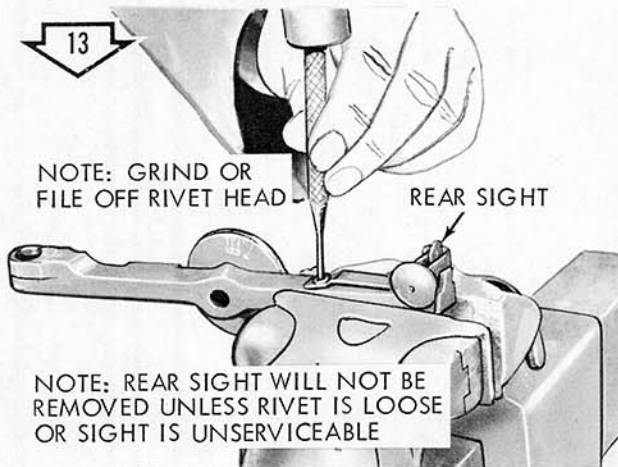

Remove rivet, washer and rear sight.

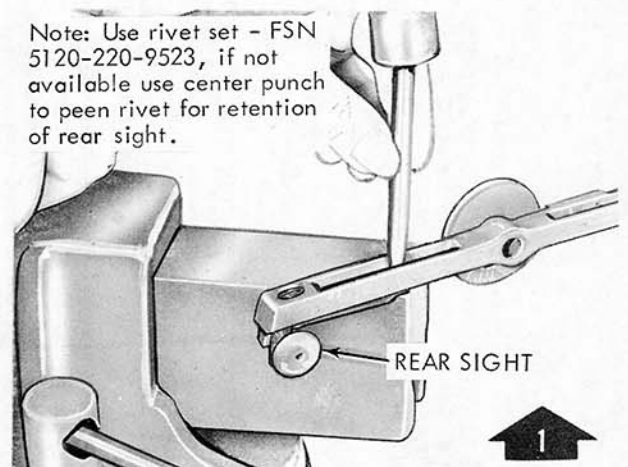

Install rivet, washer and rear sight.

WE 12507

Figure 12-11. Disassembly/Assembly of Sight Assembly. (Direct and General Support Maintenance)  
 (Page 3 of 3)

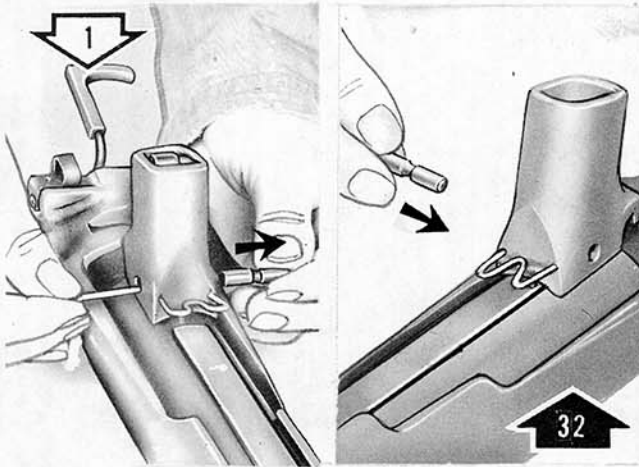

Remove/install pivot pin.

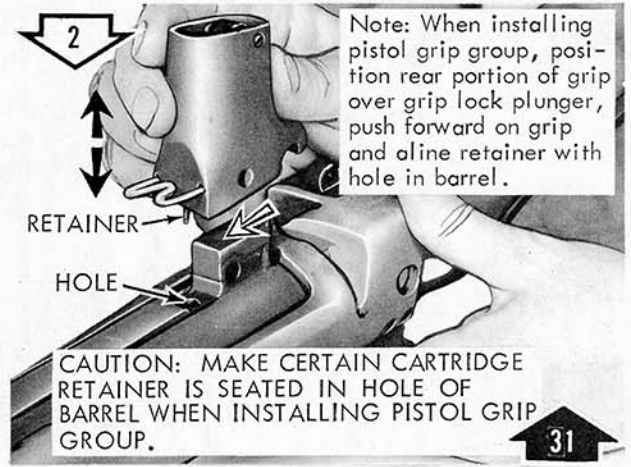

Remove/install pistol grip group.



Remove/install finger guard.



Remove/install roll pin.

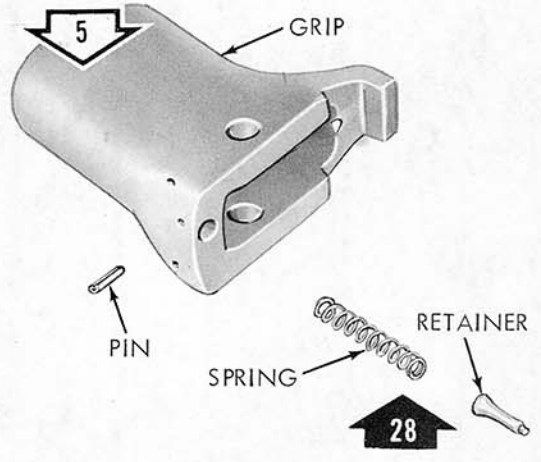

Remove/install cartridge retainer and spring.

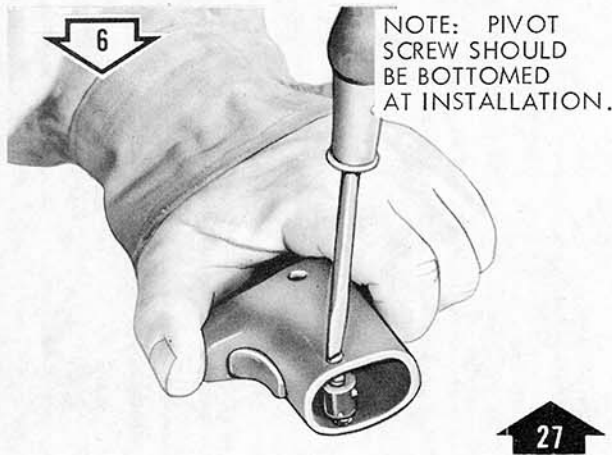

Remove/install grip release pivot screw.

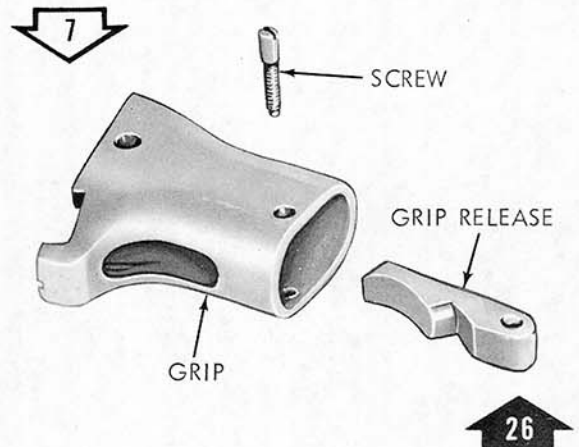

Remove/install grip release.

WE 13415

Figure 12-11A. Disassembly/Assembly of Grenade Launcher. (Direct and General Support Maintenance)  
(Page 1 of 6)

8

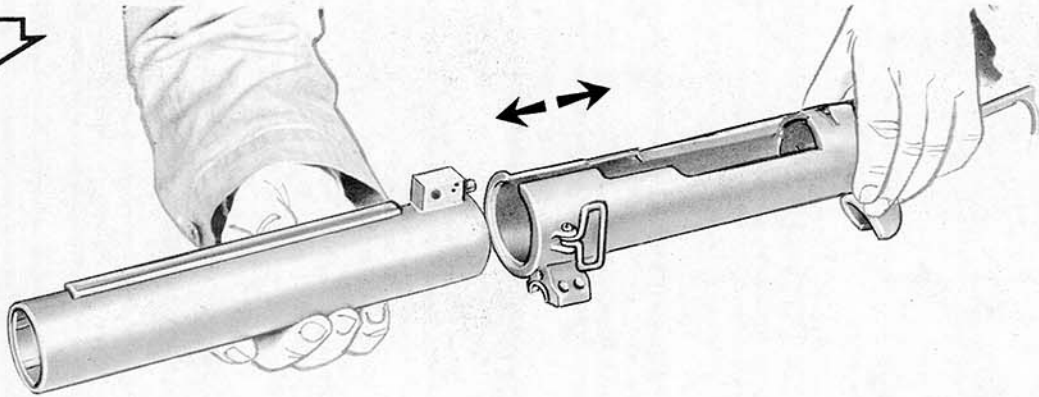

25

Remove/install barrel group.

9

CAUTION: EXERCISE CARE WHEN REMOVING OR INSTALLING THE ROLL PINS TO PREVENT FROM ENLARGING THE HOLES.

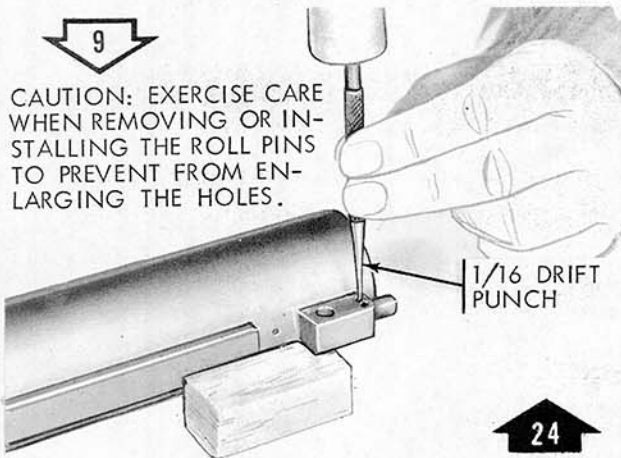

24

Remove/install roll pins.

10

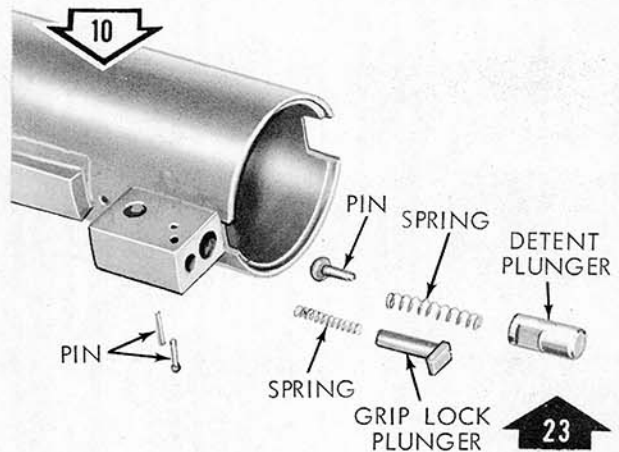

23

Remove/install detent and grip lock plungers, springs and lock pin.

11

Note: Insert punch under spring until spring clears barrel retaining pin, then push forward on spring and remove. Use reverse procedure for installation. Do not install spring through front portion of housing.

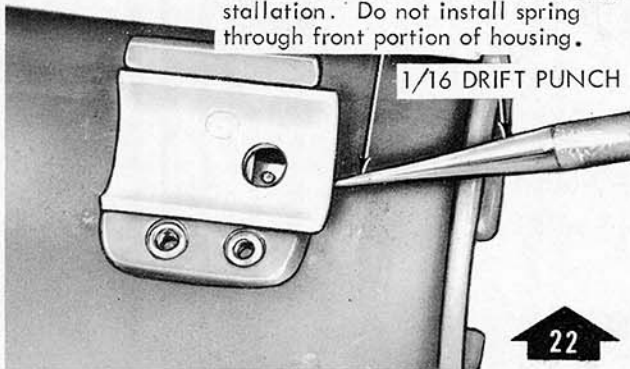

22

Remove/install barrel retaining pin spring.

12

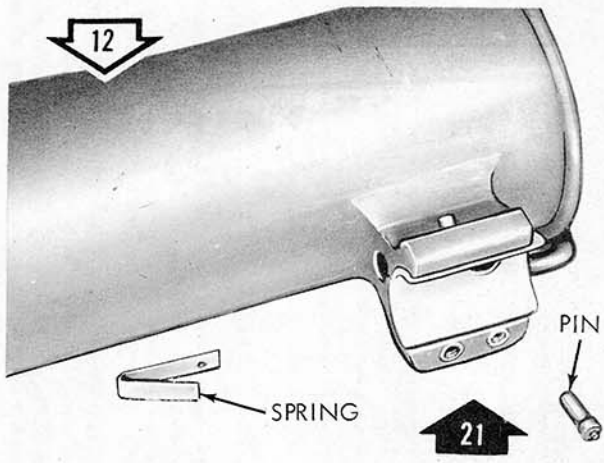

21

Remove/install barrel retaining pin.

WE 13416

Figure 12-11A. Disassembly/Assembly of Grenade Launcher. (Direct and General Support Maintenance) (Page 2 of 6)

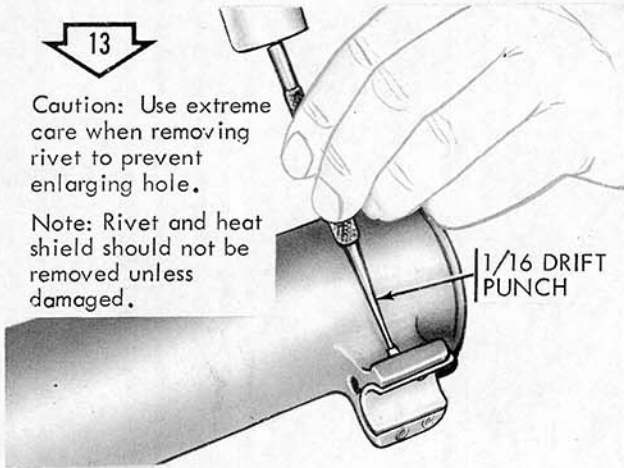

13

Caution: Use extreme care when removing rivet to prevent enlarging hole.

Note: Rivet and heat shield should not be removed unless damaged.

1/16 DRIFT PUNCH

Remove front mount rivet.

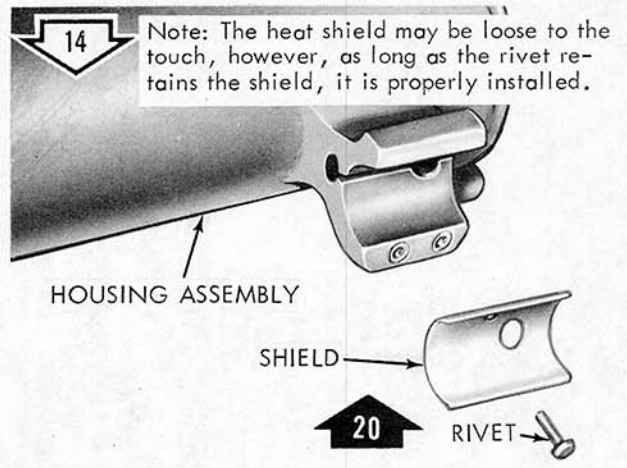

14

Note: The heat shield may be loose to the touch, however, as long as the rivet retains the shield, it is properly installed.

HOUSING ASSEMBLY

SHIELD

RIVET

Remove/Install heat shield and rivet.

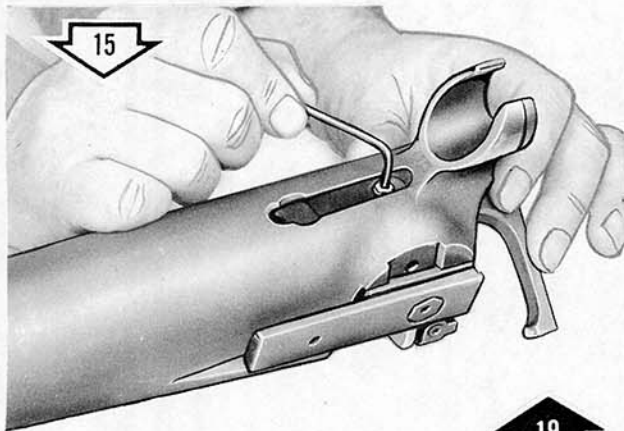

15

Remove/Install extractor screw and washer.

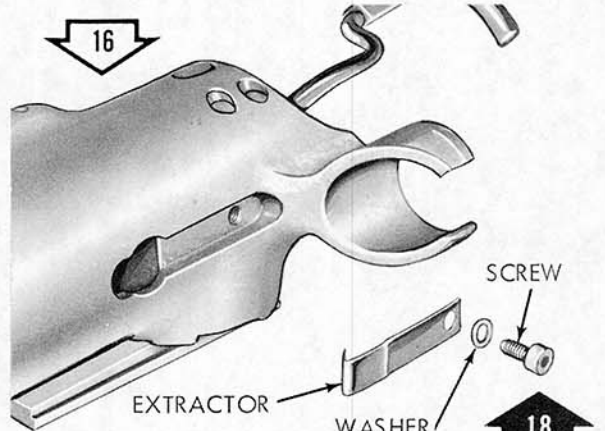

16

EXTRACTOR

WASHER

SCREW

Remove/Install extractor.

Removal: Place safety in firing position, cock launcher, rotate wrench portion of combination tool or punch, clockwise. After removal of lever, pull trigger to release firing pin.

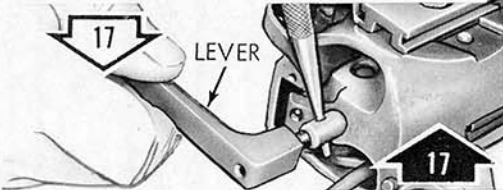

17

LEVER

17

Installation: Place safety in firing position, depress sear lever, pull firing pin rearward, insert allen wrench or drift punch in hole of firing pin. Cock launcher using wrench or punch as a handle. Turn firing pin counter-clockwise with wrench or punch to install cocking lever on firing pin.

Remove/Install cocking lever.

Note: When assembling friction bolt, proper spring tension is obtained by bottoming friction bolt and sight slide nut without over torquing.

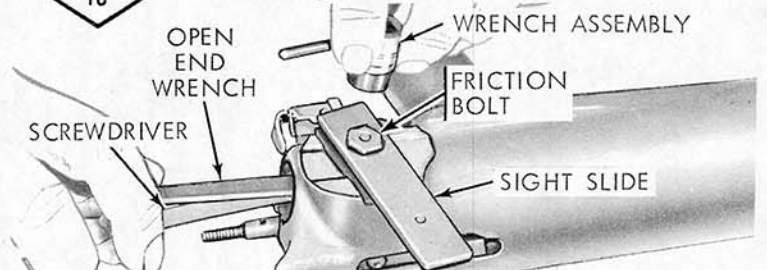

18

OPEN END WRENCH

WRENCH ASSEMBLY

FRICITION BOLT

SCREWDRIVER

SIGHT SLIDE

- A - Insert open end wrench over sight slide nut.
- B - Insert screwdriver blade between nut and launcher housing.
- C - Push up on blade and remove friction bolt using wrench assembly.

16

Remove/Install sight slide and friction bolt.

Figure 12-11A. Disassembly/Assembly of Grenade Launcher. (Direct and General Support Maintenance)  
 (Page 3 of 6)

WE 13417

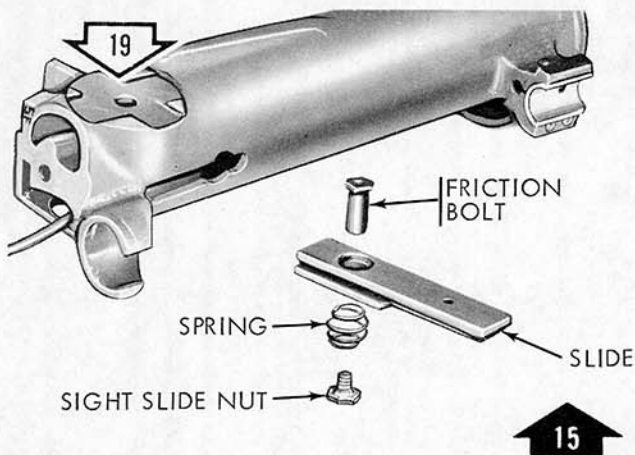

Remove/install helical compression spring and sight slide nut.

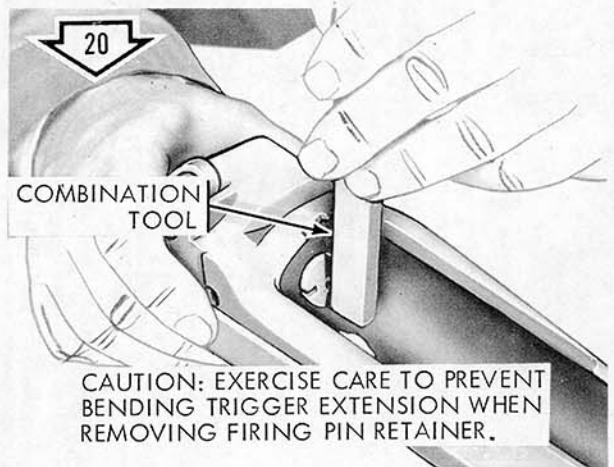

Remove firing pin retainer.

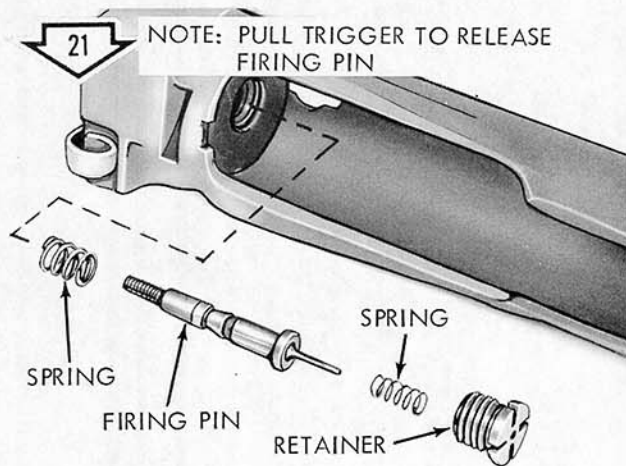

Remove buffer spring, firing pin and spring.

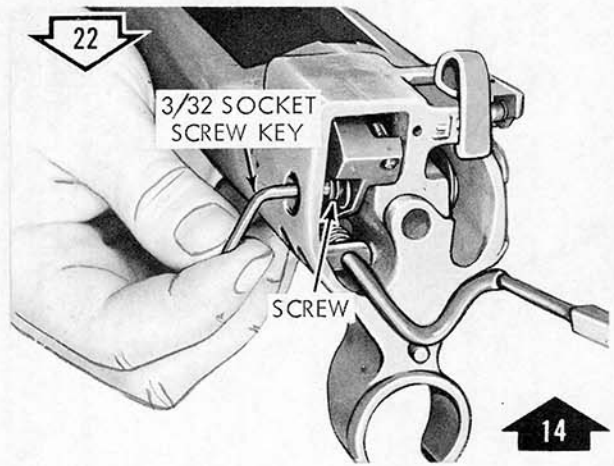

Remove/Install sear lever screw and washer.

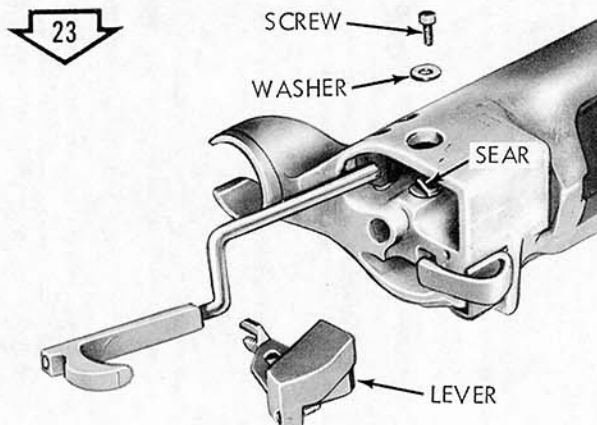

NOTE: DEPRESS SEAR WITH ALLEN WRENCH, THEN REMOVE SEAR LEVER.

Remove sear lever.

WE 13418

Figure 12-11A. Disassembly/Assembly of Grenade Launcher. (Direct and General Support Maintenance) (Page 4 of 6)

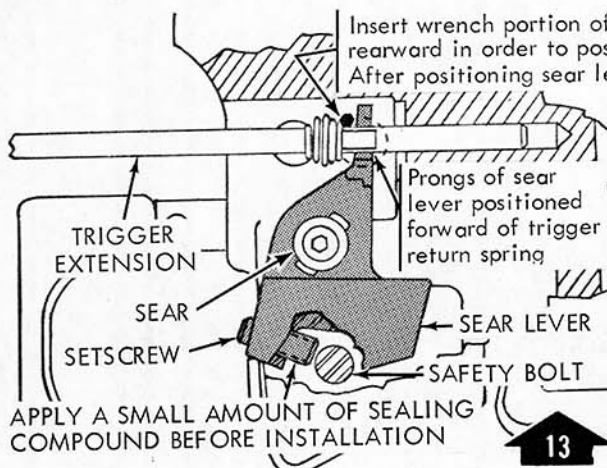

APPLY A SMALL AMOUNT OF SEALING COMPOUND BEFORE INSTALLATION

Proper position of sear lever.

NOTE: When replacing the sear lever, the safety setscrew must also be replaced. To replace and adjust, the following procedure will be followed:

- a. Install sear lever, step 12 (black arrow).
  - b. Apply a small amount of Grade "Q" primer, (FSN 8030-980-3976) to setscrew hole in sear lever and to threaded area of setscrew. The primer will rinse and reduce cure time for sealing compound, see par. C below.
- WARNING: USE SEALING COMPOUND, (FSN 8030-081-2341) FOR THE FOLLOWING APPLICATION.
- c. Apply a small amount of sealing compound to threaded area of setscrew.
  - d. With the safety in safe position, install setscrew into sear lever, using a 5/64 socket screw key.
  - e. Adjust setscrew by turning clockwise until screw touches the safety bolt, then check functioning of safety. If excessive force is required to move safety to fire position, turn setscrew counterclockwise 1/4 turns, until safety functions correctly without force. Final adjustment may require less than a 1/4 turn.

WARNING: A FINAL INSPECTOR OR SHOP SUPERVISOR WILL VERIFY ADJUSTMENT OF SETSCREW, TO INSURE PROPER FUNCTIONING OF SAFETY.

- f. After grade "Q" primer has been applied, allow 2 hours for curing.

NOTE: Sealing compound may be applied without primer, however, this will increase cure time, 10 to 12 hours.

- g. Check curing by using a 5/64 socket screw key. If setscrew will not turn, curing is sufficient.
- h. Place safety in safe position and using a 3/32 inch drill, drill out socket key portion of setscrew.

Install sear lever.

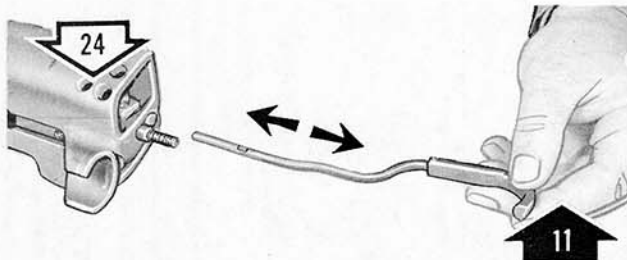
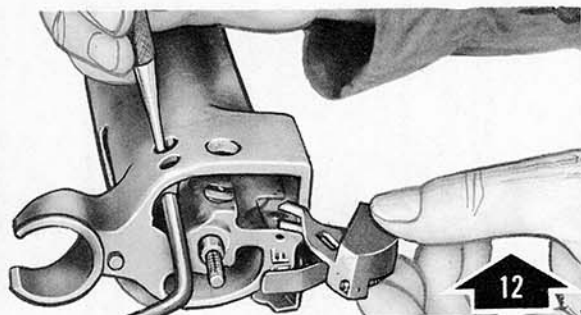

Remove/Install trigger group.

Note: During installation tighten screw only sufficiently to obtain required resistance to prevent freemovement of the trigger. Over tightening will damage the rubber ring.

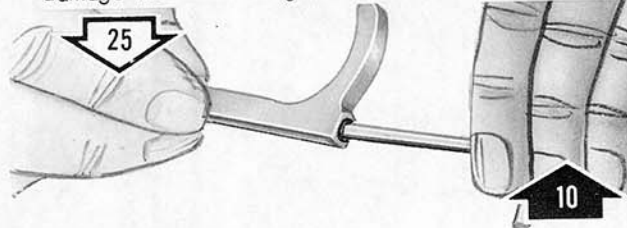

Remove/Install trigger retaining screw.

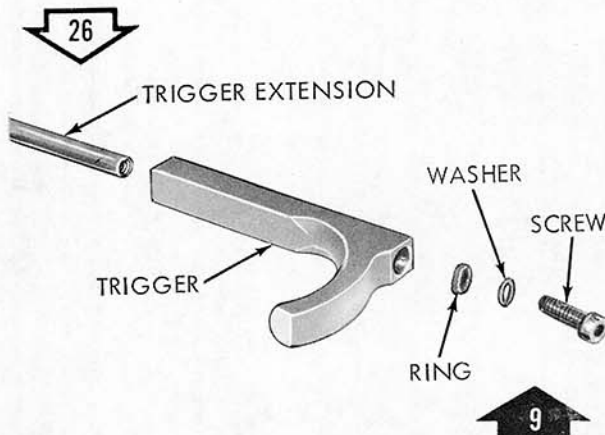

Remove/Install trigger, ring and washer.

WE 13672

Figure 12-11A. Disassembly/Assembly of Grenade Launcher. (Direct and General Support Maintenance)  
 (Page 5 of 6)

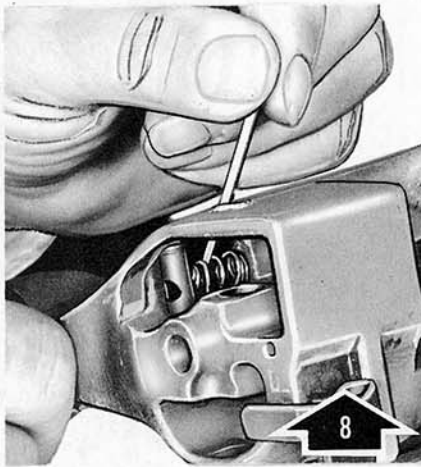

Positioning helical compression spring.



Remove/Install helical compression spring.

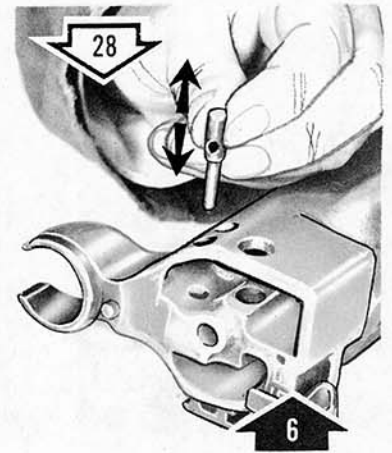

Remove/Install trigger extension support.

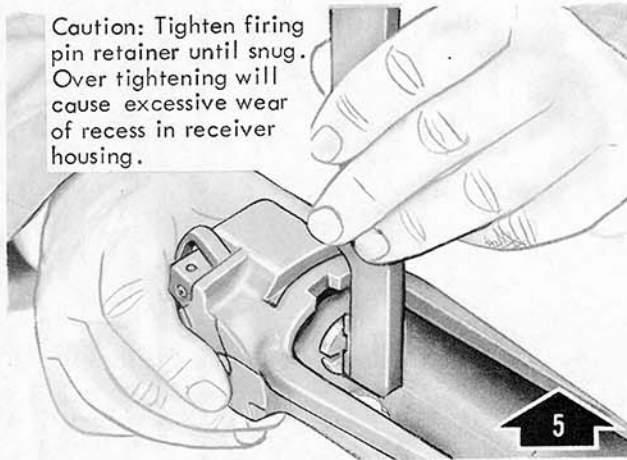

Caution: Tighten firing pin retainer until snug. Over tightening will cause excessive wear of recess in receiver housing.

Install firing pin retainer.

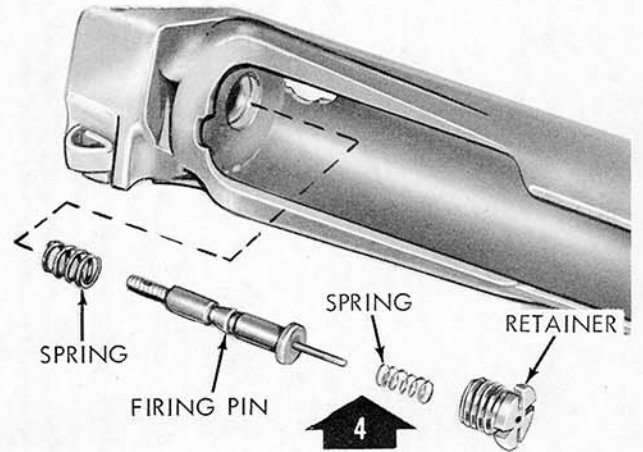

Install buffer spring, firing pin and spring.

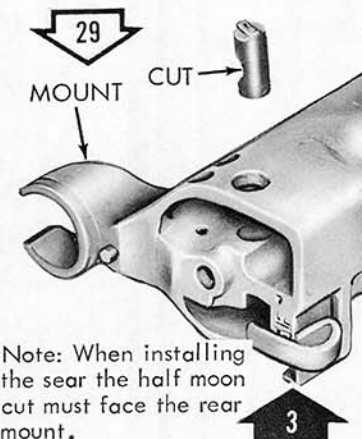

Note: When installing the sear the half moon cut must face the rear mount.

Remove/install sear.



Remove/install roll pin.

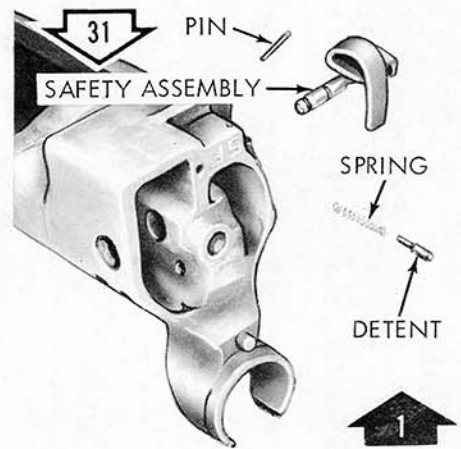

Remove/Install safety assembly, detent and spring.

WE 13760

Figure 12-11. Disassembly/Assembly of Grenade Launcher (Direct and General Support Maintenance)  
(Page 6 of 6)

12-34. CLEANING AND LUBRICATION.



12-35. For direct and general support maintenance cleaning instructions and equipment refer to TM 9-208-1, 9-208-2, and TM 9-247 and to chapter IX for materials.

The barrel is anodized aluminum. Except for lubricating oil, do not apply rust preventive materials after cleaning.

12-36. INSPECTION AND REPAIR.

12-37. Refer to table 12-4 for inspection.

TABLE 12-4. INSPECTION AND REPAIR

Part, component or area	Inspection	Replace	Repair
Hand guard	Check for dents or distortion which prevents positive retention of hand guard on rifle. Inspect for loose liner.	(1, fig. 9-4)	
Clamp and heat shield assembly	Check for cracks in heat shield, loose rivet and for bent or broken clamp and bar. Check front mount screws for security, bent body, or sheared heads.	(4, fig. 9-4)	Straighten bar, if bent, replace, if broken. Tighten screws; replace, if damaged.
Sight assembly	Check for missing or broken springs. Inspect detents and the serrations of sight base for wear. Check friction setting (7, fig. 12-10). Inspect for loose rivet on rear sight assembly and legibility of markings on sight base and rear sight assembly.	(5, fig. 9-4)	(Fig. 9-5). Note. If sight markings are not legible apply white paint to indentations to clarify the markings.
Sight slide	Check for burrs and functioning on housing.	(17, fig. 9-4)	Remove burrs or replace.
Pistol grip group	Check for proper functioning, broken, worn, or missing parts.	(7A, B, C, D, E, F, and G, fig. 9-4)	(7, fig. 9-4)
Barrel group	Inspect barrel for cracks and general condition. Inspect all parts for wear and damage.	(8A, B, C, D, E, F, G, and H, fig. 9-4)	(8, fig. 9-4)

TABLE 12-4. INSPECTION AND REPAIR - (CONTINUED)

Part, component or area	Inspection	Replace	Repair
Barrel retaining pin and spring	Inspect for worn pin and broken spring.	(11, 12, fig. 9-4)	(11, 12, fig. 9-4)
Heat shield and rivet	Inspect for broken or cracked heat shield and loose rivet.	(9, 10, fig. 9-4)	(9, 10, fig. 9-4)
Extractor	Inspect for being bent, broken or cracked. Check extractor screw and tighten if necessary.	(15, fig. 9-4)	
Sear lever	Inspect for wear or damage.	(22, fig. 9-4)	
Trigger group	Inspect for worn or missing parts.	(24A, B, C, D, E, fig. 9-4)	(24, fig. 9-4)
Trigger extension support	Inspect for wear.	(26, fig. 9-4)	
Cocking lever	Check for missing lever or damaged threads.	(27, fig. 9-4)	
Firing pin retainer	Check for burrs, worn slots, damaged threads and enlarged firing pin hole.	(28, fig. 9-4)	Remove burrs (28, fig. 9-4)
Firing pin	Inspect for wear, burrs, damaged threads and bind between pin and sear.	(30, fig. 9-4)	Remove burrs (30, fig. 9-4)
Sear	Inspect for burrs, wear and damaged threads.	(32, fig. 9-4)	Remove burrs (32, fig. 9-4)
Safety assembly and plunger detent	Check for proper functioning.	(34, fig. 9-4) (35, fig. 9-4)	
Housing assembly	Inspect for burrs, scratches, nicks or damage, shiny spots and retention of sling swivel. Due to the fact the housing is made of aluminum, scratches and abrasions will be more prevalent than on weapons made of steel.	(39, 39A, fig. 9-4)  (37, 37A, fig. 9-4)	Remove burrs and touch up shiny spots with black lusterless paint.  Tighten or replace front sling retaining nut and screw.