

OPERATOR'S MANUAL FOR:

Colt® Advanced Law Enforcement Carbines

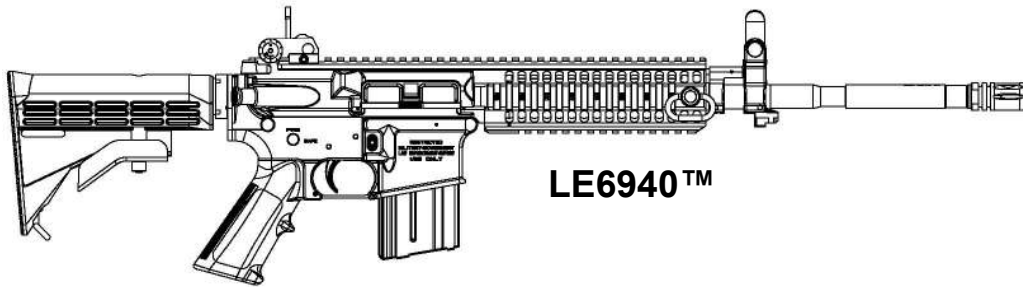

LE6940™

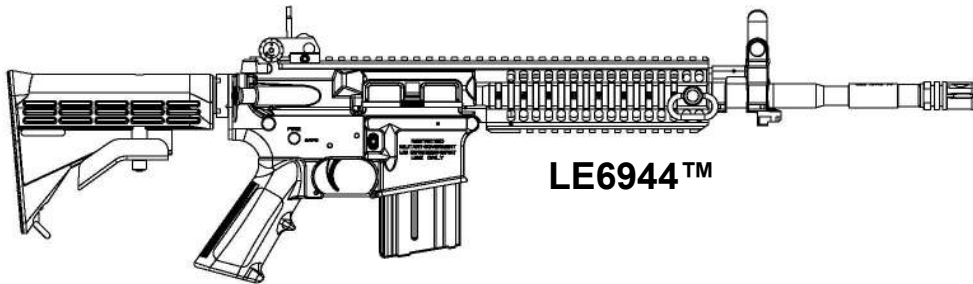

LE6944™

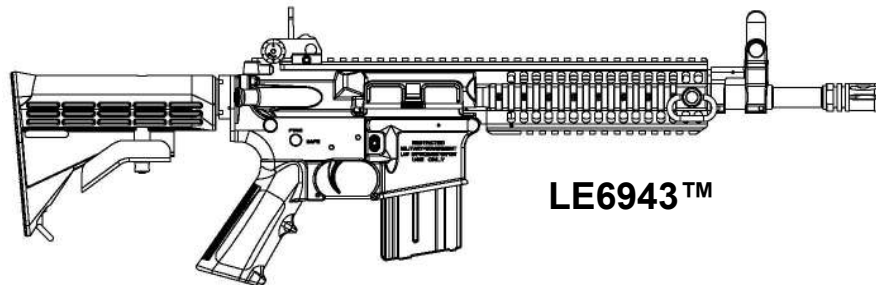

LE6943™

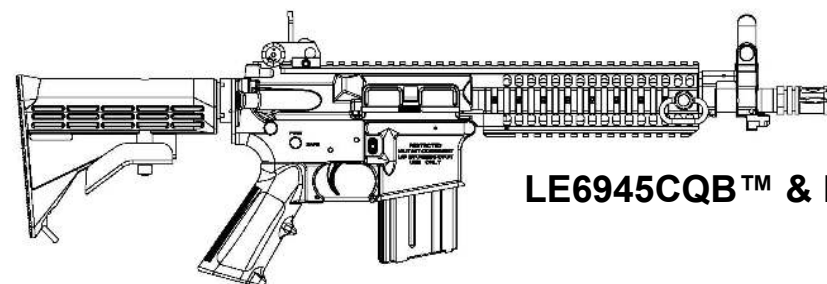

LE6945CQB™ & LE6946CQB™



COPYRIGHT© 2010 COLT DEFENSE LLC ALL RIGHTS RESERVED
"Information contained in this publication is free of "ITAR" restricted data"



**Read the instructions, warnings and cautions in this manual
CAREFULLY BEFORE using this firearm.**

SAFETY DEPENDS ON YOU

NOTICE

Colt shall not be responsible for injury, death, or damage to property resulting from either intentional or accidental discharge of this firearm, or from its function when used for purposes or subjected to treatment for which it was not designed. Colt will not honor claims involving this firearm, which result from careless or improper handling, unauthorized adjustment or parts replacement, corrosion, neglect, or the use of wrong caliber ammunition, or the use of ammunition other than high quality commercially manufactured ammunition in good condition, or any combination thereof. Colt will not honor claims involving this firearm for any reason or cause when such claims are made by the second or subsequent owner.

IMPORTANT

Before it left the factory this firearm was tested, carefully inspected, and packaged. Colt cannot control product handling after it leaves the factory; therefore, please examine this firearm carefully at the time of purchase to insure that it is unloaded and undamaged. The dealer will be pleased to assist you in making this examination and endeavor to answer your further questions.

This instruction manual should always accompany this firearm. When you lend, give, or sell this firearm, be sure this manual goes with it. If you need a replacement manual, see [page 60](#) for advice.



READ AND UNDERSTAND ALL THE FOLLOWING WARNINGS AND CAUTIONS BEFORE REMOVING THIS FIREARM FROM ITS PACKAGE

This Colt product is classified as a Firearm by the Bureau of Alcohol, Tobacco, Firearms, and Explosives. You must follow the safety instructions for your safety and the safety of others.

SAFETY DEPENDS ON YOU

About **WARNINGS** and **CAUTIONS**

Throughout this Operator's Manual, you will find **WARNINGS** and **CAUTIONS** in bold print. All **WARNINGS** and **CAUTIONS** must be read carefully and followed completely. **WARNINGS** discuss issues that could result in damage to your firearm, or serious injury or death to you or a bystander. **CAUTIONS** discuss issues that could result in damage or malfunction of your firearm or cause injury. Read and understand all the **WARNINGS** and **CAUTIONS** before removing the firearm from its package.

 **WARNING:** IF THIS FIREARM IS CARELESSLY OR IMPROPERLY HANDLED, UNINTENTIONAL DISCHARGE COULD RESULT AND COULD CAUSE INJURY, DEATH, OR DAMAGE TO PROPERTY.

 **WARNING:** IF THE BARREL IS VERY HOT FROM FIRING THERE IS A RISK THAT A CARTRIDGE IN THE CHAMBER COULD DISCHARGE BY ABSORBING HEAT FROM THE BARREL ("COOK-OFF"). THIS CAN OCCUR AT ANY TIME. WHEN COOK-OFF IS SUSPECTED, THE CHAMBER MUST BE CLEARED IMMEDIATELY AFTER FIRING. (See [pages 54 & 55](#) for more information).

 **WARNING:** ALWAYS BE AWARE OF POSSIBLE RISK FROM DROPPING YOUR FIREARM. SOME PARTS OF THE MECHANISM COULD BE DAMAGED ALTHOUGH YOU MAY NOT SEE THE DAMAGE. A DAMAGED FIREARM COULD DISCHARGE AND CAUSE INJURY, DEATH OR DAMAGE TO PROPERTY. If your firearm has been dropped, have your firearm examined by a competent gunsmith or return it to Colt for Service.

 **WARNING:** DO NOT ALTER PARTS AS THIS MAY RESULT IN THE PREMATURE WEARING OF PARTS OR REDUCE THE LEVEL OF SAFETY, CAUSING THE FIREARM TO MALFUNCTION. A MALFUNCTION CAN RESULT IN AN ACCIDENTAL DISCHARGE, WHICH COULD CAUSE SERIOUS INJURY, DEATH OR DAMAGE TO PROPERTY. If any parts do not function properly, have your firearm examined by a competent gunsmith or return it to Colt for Service.

 **WARNING:** WHEN YOU SQUEEZE THE TRIGGER, *YOU* MUST EXPECT THE FIREARM TO FIRE, AND *YOU* MUST TAKE FULL RESPONSIBILITY FOR FIRING IT. *YOUR* CARE CAN AVOID ACCIDENTAL DISCHARGE, AND *YOU* WILL THEREBY AVOID ACCIDENTAL INJURY AND DEATH.

 **WARNING:** THIS FIREARM MAY DISCHARGE ACCIDENTALLY WHEN A ROUND IS FED INTO THE CHAMBER, IF IT IS DROPPED OR RECEIVES A BLOW TO THE MUZZLE OR FRONT OF THE FIREARM. This can occur regardless of the position of the hammer or any of the various safety devices. Therefore, extra care and strict adherence to these instructions by the firearm user is mandatory for minimizing the risk of accidents.

SAFETY DEPENDS ON YOU

 **WARNING:** KEEP CLEAR AND KEEP OTHERS CLEAR OF THE EJECTION PORT. Spent cartridges are ejected with enough force to cause injury, and the ejection port must be unobstructed by your hand to insure safe ejection. Never place fingers in ejection port; they could be burned by hot metal or injured by the bolt moving forward.

 **WARNING:** NEVER DRY FIRE YOUR FIREARM WHEN THE RECEIVERS ARE OPEN as the level of safety could be reduced.

 **WARNING:** ALWAYS HANDLE YOUR FIREARM AS IF IT WERE LOADED so that you never fire it accidentally when you think it is unloaded.

 **WARNING:** NEVER POINT YOUR FIREARM AT ANYTHING YOU DO NOT INTEND TO SHOOT to prevent injury or death in the event of an accidental discharge.

 **WARNING:** NEVER LEAVE A LOADED FIREARM UNATTENDED. Someone, especially a child, may fire it and cause injury, death, or damage to property.

 **WARNING:** NEVER LEAVE A FIREARM COCKED READY TO FIRE as this condition is extremely dangerous, and the firearm could easily be accidentally discharged, causing injury, death, or damage to property.

 **WARNING:** NEVER TAKE ANYONE'S WORD THAT A FIREARM IS UNLOADED; check for yourself with your finger off the trigger and firearm pointed in a safe direction, so that you never fire the firearm accidentally when you think it is unloaded.

 **WARNING:** ALWAYS BE SURE YOUR BACKSTOP IS ADEQUATE to stop and contain bullets before firing so that you do not hit anything outside your shooting area. A bullet can travel through or past your target up to 3 miles... if in doubt, don't shoot

 **WARNING:** NEVER DRINK ALCOHOLIC BEVERAGES OR TAKE DRUGS BEFORE OR DURING SHOOTING, as your judgment, vision, and motor skills could be seriously impaired making your firearm handling unsafe.

 **WARNING:** NEVER SHOOT AT A HARD SURFACE SUCH AS ROCK, OR A LIQUID SURFACE SUCH AS WATER. A bullet may ricochet and travel in any direction to strike you, or an object you cannot see, causing injury, death, or damage to property.

 **WARNING:** NEVER DISCHARGE A FIREARM NEAR FLAMMABLE MATERIAL. Flame and sparks erupt from the firearm when it is discharged. Which could ignite flammable materials or cause gasses to explode.

 **WARNING:** ALWAYS WEAR AND ENCOURAGE OTHERS TO WEAR EYE AND EAR PROTECTION.

SAFETY DEPENDS ON YOU

TABLE OF CONTENTS

TITLE	PAGE NO.
Cover	1
About Warnings and Cautions	2-4
Table of Contents	5
Illustration of Firearm	6
Description	7
Characteristics of Firearm	7-9
Firing Characteristics	10
Operating Features	11-14
Maintenance:	
Field Stripping	15-20
Cleaning Materials	21
Cleaning Procedure	21-23
Lubrication	24-25
Assembly	26-30
Reversible Selector Lever	31-32
Functional Checks	33-36
Malfunctions and Trouble Shooting	37-42
Magazine	43-44
Operation:	
Folding Sights	45-46
Loading	47-48
Aiming and Firing	49-50
Unloading	51-52
Stoppages and Immediate Actions	53
Dangerous Situations	54-56
Misfires and Cook-offs	54-55
Bore obstructions	56
Health and Environmental	56
Storage	57
Firearms Record	57
Limited Lifetime Service Agreement	57
Servicing and Repair	58

SAFETY DEPENDS ON YOU

ILLUSTRATION OF FIREARM

COLT ADVANCED LAW ENFORCEMENT CARBINES

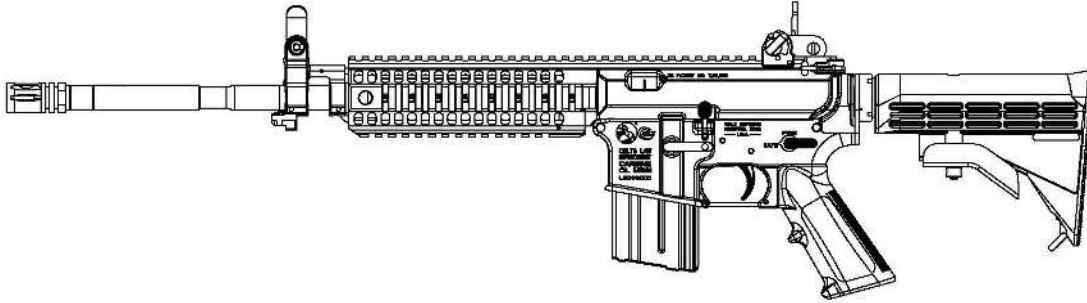

LEFT SIDE VIEW (LE6940™)

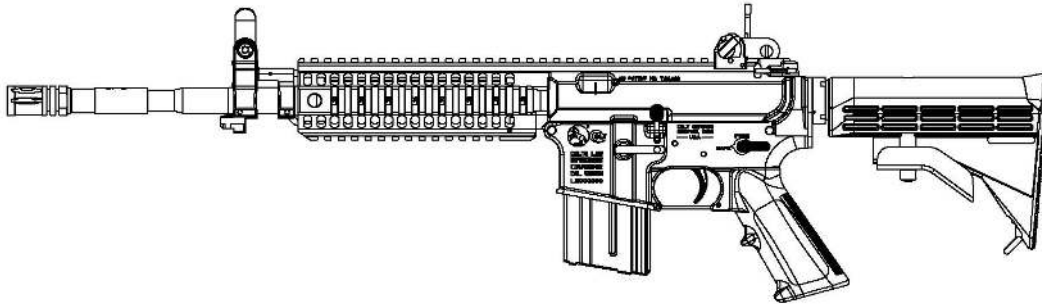

LEFT SIDE VIEW (LE6944™)

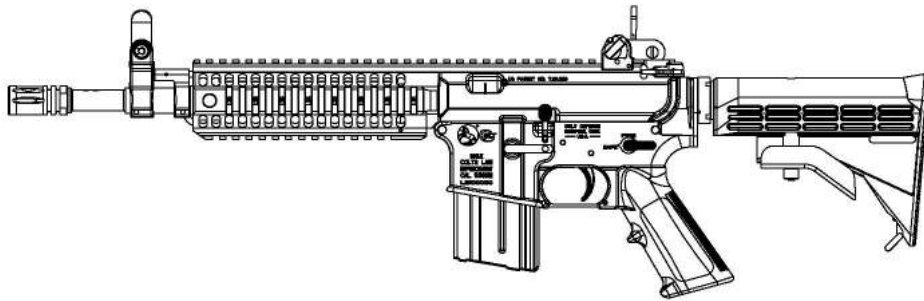

LEFT SIDE VIEW (LE6943™)

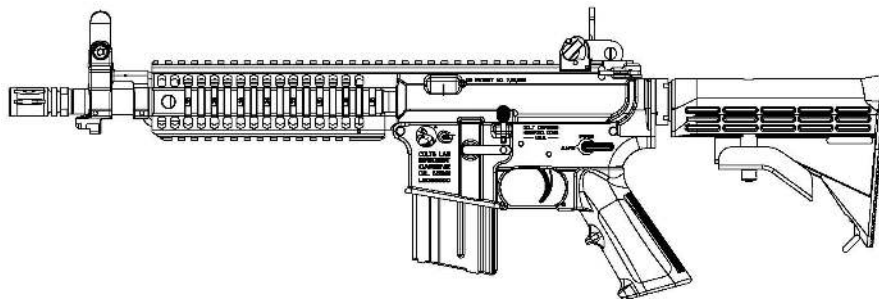

LEFT SIDE VIEW (LE6945CQB™ & LE6946CQB™)

SAFETY DEPENDS ON YOU

DESCRIPTION:

This operator's manual describes the Colt Advanced Law Enforcement Carbines and includes information on their features.

The Colt Advanced Law Enforcement Carbines are lightweight, gas operated, magazine fed, 5.56 x 45mm caliber carbines. They are based on the M16/M4 series of rifles and incorporate the same safety features as those firearms. The unique design of the Colt Advanced Law Enforcement Carbines feature a monolithic upper receiver with MIL-STD-1913 rails at the 12, 3, and 9 o'clock positions as well as a lower rail system with a MIL-STD-1913 rail at the 6 o'clock position.

CHARACTERISTICS OF FIREARM:

TYPE OF FIREARM:

Gas operated, 5.56x45mm caliber, using a gas operated bolt and carrier system.

Air-cooled, magazine fed, and semi-automatic action.

Adjustable back-up iron sight (BUIS) and front sight are provided along with MIL-STD-1913 rails for mounting optical sights and other accessories.

SAFETY DEPENDS ON YOU

CHARACTERISTICS OF FIREARM (Cont.)

LE6940 Specifications:

Length: 35.5 inches extended 32.0 inches retracted
Barrel Length: 16.1 inches (rifling 1 in 7 twist)
Weight: 6.85 lbs (unloaded)

LE6944 Specifications:

Length: 34.0 inches extended 30.5 inches retracted
Barrel Length: 14.5 inches (rifling 1 in 7 twist)
Weight: 6.60 lbs (unloaded)

LE6943 Specifications:

Length: 31.0 inches extended 27.5 inches retracted
Barrel Length: 11.5 inches (rifling 1 in 7 twist)
Weight: 6.45 lbs (unloaded)

LE6945CQB & LE6946CQB Specifications:

Length: 29.5 inches extended 26.0 inches retracted
Barrel Length: 10.3 inches (rifling 1 in 7 twist)
Weight: 6.25 lbs (unloaded)

FIRING CHARACTERISTICS- FIRE CONTROLS:

LE6940: "SAFE" & "FIRE" (semi-auto)
LE6944: "SAFE" & "FIRE" (semi-auto)
LE6943: "SAFE" & "FIRE" (semi-auto)
LE6945CQB: "SAFE" & "FIRE" (semi-auto)
LE6946CQB: "SAFE", "SEMI", & "AUTO"

SAFETY DEPENDS ON YOU

CHARACTERISTICS OF FIREARM (Cont.)

AMMUNITION:

5.56 x 45mm NATO Cartridge

&

.223 Rem.

The Colt Advanced Law Enforcement Carbines are chambered with a longer throat to accommodate the 5.56x45mm NATO military M193, M855, SS109, and MK262 ammunitions. As a result, these Carbines also can safely use .223 Remington sporting cartridges having a lower chamber pressure.



WARNING: NEVER USE AMMUNITION NOT SPECIFICALLY DESIGNATED FOR USE IN YOUR FIREARM. FAILURE TO USE CORRECT TYPE OR CALIBER OF AMMUNITION MAY CAUSE THE FIREARM TO JAM, FAIL TO FIRE OR MAY GENERATE EXCESSIVE PRESSURE WHICH CAN DAMAGE OR EVEN RUPTURE YOUR FIREARM, CAUSING PERSONAL INJURY, DEATH, OR PROPERTY DAMAGE. To protect you from danger and your rifle from damage, Colt does not recommend the use of handloads or remanufactured ammunition.

SAFETY DEPENDS ON YOU

FIRING CHARACTERISTICS:

Cyclic Rate of Fire:

700-900 rounds per minute (this is the theoretical number of cartridges which could be fired automatically in one minute).

Maximum Effective Rate Of Fire:

Semi-Automatic	45-65 Rounds Per Minute
Fully-Automatic	150-200 Rounds Per Minute
Sustained Rate Of Fire	12-15 Rounds Per Minute

(Sustained Rate Of Fire- The actual rate of fire that the firearm can fire for an indefinite length of time without serious overheating of the barrel.)

With a 1 turn in 7-inch twist for rifling, M193, M855, MK262, and .223 Remington ammunition may be fired. Muzzle velocity, muzzle energy, and maximum effective range will vary depending on barrel length and ammunition used.

MUZZLE VELOCITY AND ENERGY

<u>AMMUNITION</u>	<u>5.56 X 45mm NATO</u> <u>M855 or SS109</u>	
	<u>feet/sec.</u>	<u>Meters/sec.</u>
LE6940	2920	890
LE6944	2870	875
LE6943	2610	796
LE6945CQB & LE6946CQB	2600	792
<u>Muzzle Energy</u>	<u>foot-pounds</u>	<u>joules</u>
LE6940	1174	1592
LE6944	1136	1540
LE6943	938	1272
LE6945CQB & LE6946CQB	931	1263

SAFETY DEPENDS ON YOU

OPERATING FEATURES:

NAME OF COMPONENT AND DESCRIPTION OF ITS FUNCTION (numbers in parentheses correspond with diagrams on [pages 13 & 14](#)):

Charging Handle (1): Retracts bolt carrier.

Sights (2,4): Used to align firearm with target. Rear sight (2) is fully adjustable. The front sight is adjusted only on zeroing. Both sights may be folded down when not in use. The front sight (4) is Colt's proprietary folding design containing an adjustable front sight post. There is a MIL-STD-1913 rail (2a) built into the monolithic upper receiver to which various optical sights or other accessories can be secured. There are markings on these rails to show locations for mounting accessories. The markings allow the user to safely place the accessory back in the same location where it was mounted before being removed. Additional rails are located on both sides and the bottom.

Bolt & Bolt Carrier Assembly (3): Provides stripping, chambering, locking, firing, extraction and ejection of cartridges using the action spring and projectile gases for power.

Compensator (5): Reduces muzzle flash, helps keep muzzle from rising during firing, protects muzzle end of barrel and reduces signature when firing.

Ejection Port Dust Cover (6): Keeps dirt and dust out of chamber. Opens automatically when bolt carrier moves forward or rearward.

Fired Cartridge Case Deflector (6a): Deflects fired cartridge cases clear when firing.

Magazine (7): Compatible with standard 20 round (NSN 1005-00-056-2237) & optional 30 round capacity M16/M4 Aluminum Magazines (NSN 1005-00-921-5004)

Magazine Release Button (8): Releases the magazine for removal.

SAFETY DEPENDS ON YOU

OPERATING FEATURES (Cont.)

Forward Assist Assembly (9): Provides a means of pushing bolt carrier forward if the bolt fails to close and lock. **Note:** When you need to use the forward assist, it is usually time to clean your firearm or a sign of a defective cartridge. Always check the ammunition for damage before using the forward assist.

 **WARNING: FORCING DAMAGED AMMUNITION INTO THE CHAMBER COULD DAMAGE YOUR FIREARM AND COULD RESULT IN INJURY, DEATH, OR DAMAGE TO PROPERTY.**

Bolt Catch (10): Holds bolt carrier in open position.

Selector Lever (11): **Selects mode of operation:**
“SAFE” -- TRIGGER LOCKED
“SEMI” or “FIRE” -- SEMI-AUTOMATIC (Single Shot)
“AUTO” -- FULLY AUTOMATIC

Note that the selector lever on the “semi-auto” models is reversible and may be changed from one side to the other. See assembly instruction on [pages 31 & 32](#).

Buttstock Assembly (12): Sliding buttstock has four positions and may be positioned to suit the operator

Quick Detach Sling Swivel (52): Allows the user to place the sling mount on either the 9 or 3 o'clock rails of the upper receiver/handguard.

Lower Rail (62): Provides protection from the barrel heat and provides Mil-Std-1913 rails at the 6 o'clock position.

SAFETY DEPENDS ON YOU

OPERATING FEATURES (Cont.)

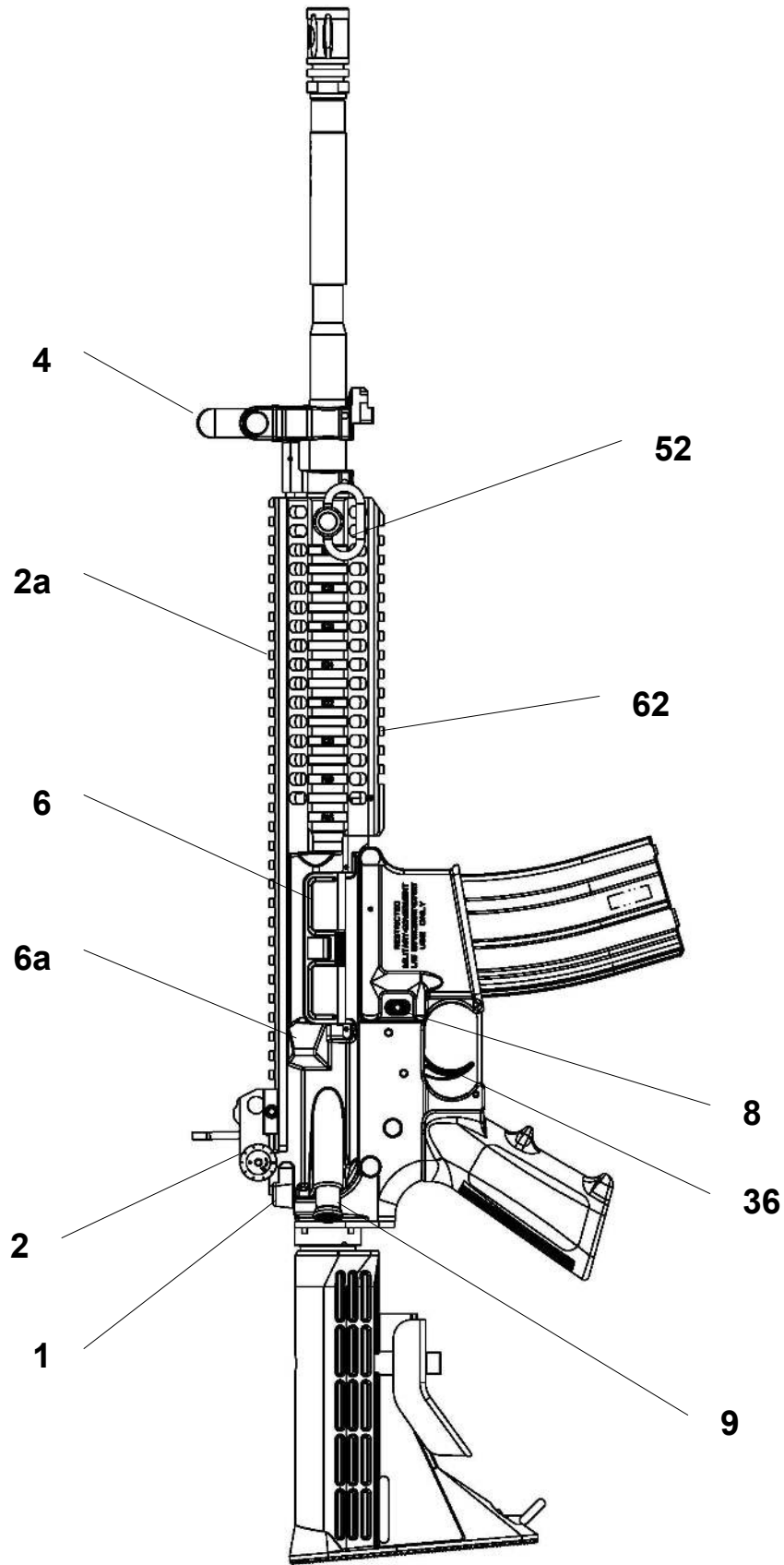

SAFETY DEPENDS ON YOU

MAINTENANCE:

Maintenance instructions tell the operator how to field strip, clean, lubricate, assemble and do a functional check on the firearm. Like any other precision mechanism, your firearm will perform better, last longer, and remain safer when it is properly maintained. Follow the instruction in this section to keep your firearm in good condition. A table at the end of this section deals with malfunctions and troubleshooting.

Tools Required: Cleaning kit.

Materials required: Dry, lint free cloth.

Break-Free® CLP or equivalent.

Note: If firearm has been used in salt air, water, mud, or sand, it must be completely disassembled, cleaned and inspected.

 **WARNING:** ALWAYS ENSURE THAT THE FIREARM IS UNLOADED BEFORE FIELD STRIPPING, CLEANING, LUBRICATING, AND/OR ASSEMBLING. ALWAYS KEEP THE MUZZLE POINTED IN A SAFE DIRECTION. IF THIS FIREARM IS CARELESSLY OR IMPROPERLY HANDLED, AN ACCIDENTAL DISCHARGE COULD RESULT AND COULD CAUSE SERIOUS INJURY, DEATH, OR DAMAGE TO PROPERTY.

 **WARNING:** WEAR SAFETY GLASSES IN CASE YOU LOSE CONTROL OF SOME SPRING LOADED COMPONENTS WHICH COULD CAUSE INJURY.

FIELD STRIPPING:

1. Rotate selector (11) to "SAFE" position.
2. Press magazine release button (8) and remove magazine (7).
3. Pull charging handle (1) rearward; check that chamber (15) is empty; release charging handle.
4. Ensure bolt is fully forward, push left end of takedown pin (13) into receiver. Pull pin to right until stopped by detent. Pivot upper receiver (29) from lower receiver (32) to expose the rear of the bolt carrier assembly (3).
5. Pull charging handle (1) about three inches rearward, remove bolt carrier assembly (3).
6. Remove charging handle (1) by aligning with slot in upper receiver and pulling down and to the rear.

Note: When an optical sight or other accessory is installed, it can be left in place for routine cleaning or it can be removed from the MIL-STD-1913 sight rail (2a).

SAFETY DEPENDS ON YOU

FIELD STRIPPING (Cont.)

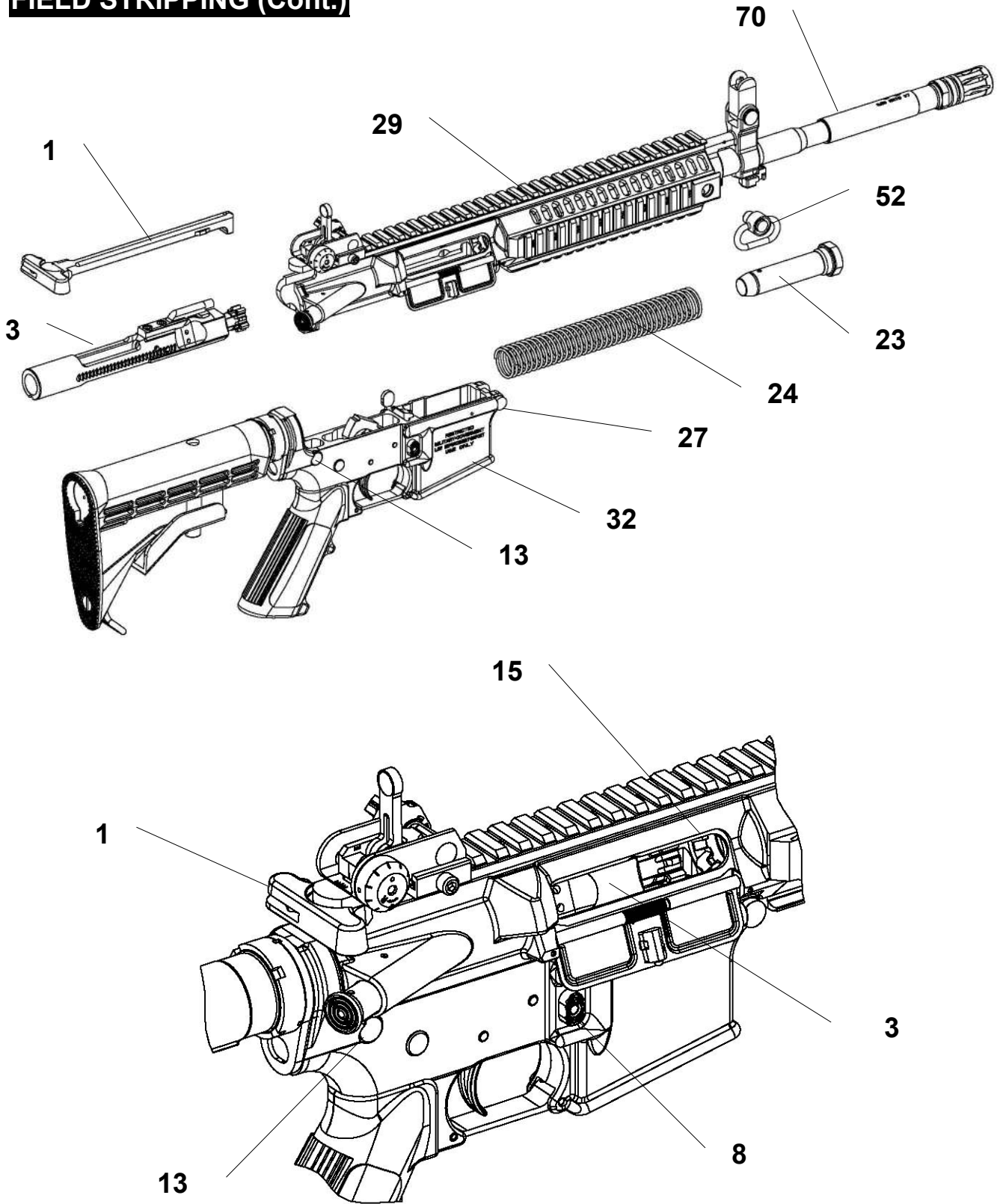

SAFETY DEPENDS ON YOU

FIELD STRIPPING (Cont.)

9. With hammer (22) in cocked position, push buffer assembly (23) rearward to control the spring tension. Press buffer retainer (25) down. Slowly ease buffer forward until clear of retainer.
10. Continue to hold buffer against spring tension, press hammer (22) down just enough to clear buffer and remove buffer assembly (23) and action spring (24) from the receiver extension tube (31).
11. Removal of Lower Rail (Optional- not necessary for routine cleaning)
 - A. First remove the quick detach sling swivel (52), if rail covers are mounted on the 9 and 3 o'clock rails, they must also be removed to allow the lower rail (62) to drop freely from the upper receiver (29)
 - B. Then push in the lower rail lock (53) with a cartridge or a pin punch (see arrow)
 - C. Then slide the lower rail (62) forward approximately 3/8" while pushing in on the lower rail lock (53) and pull down to remove.

Rail Covers

There are three rail covers provided in the accessory kit. The rail covers are 7 inches in length and will cover 17 slots of the rail. They are designed to be cut for custom fitting to the rail and can be cut with scissors or a sharp knife.

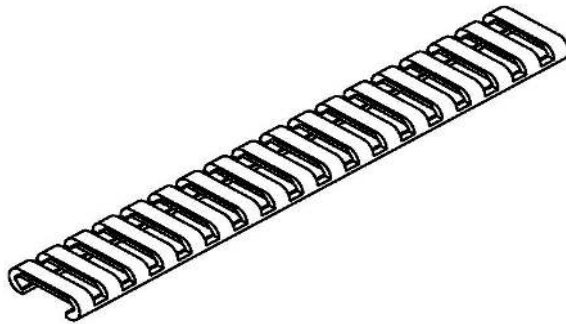

12. Pull lever (30) down and slide the buttstock assembly (12) rearward off receiver extension tube (31).

IMPORTANT: Do not field strip your firearm further than previously described. If you do so you may void your limited lifetime service agreement. If additional maintenance is required, make sure that the firearm is NOT LOADED and return it to Colt for service. For spare parts, seek advice from the Dealer who should have information on how to obtain genuine Colt parts, or contact Colt Customer Service.

SAFETY DEPENDS ON YOU

FIELD STRIPPING (Cont.)

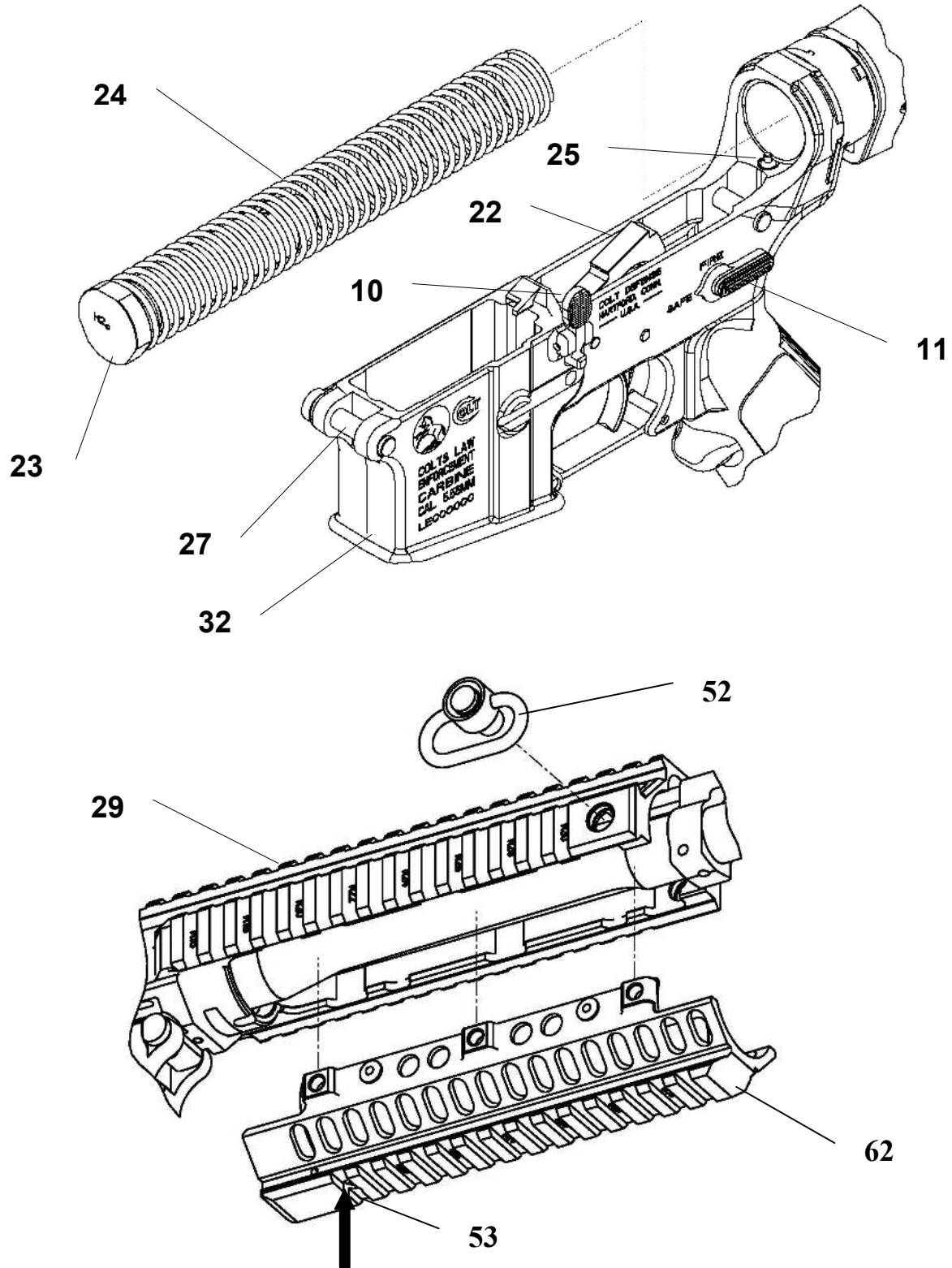

SAFETY DEPENDS ON YOU

FIELD STRIPPING (Cont.)

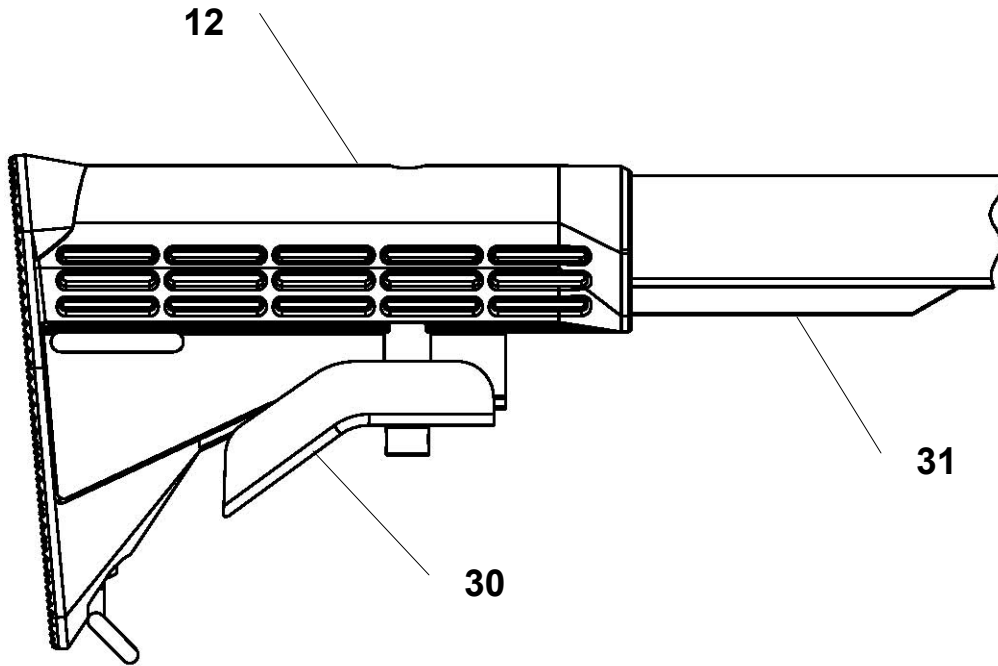

REMOVAL/INSTALLATION OF BUTTSTOCK

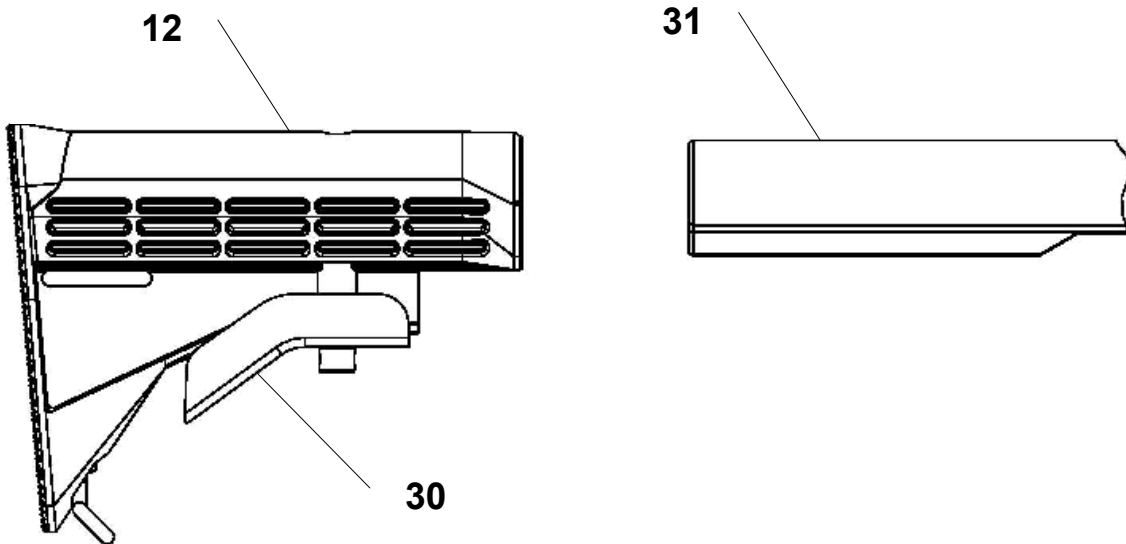

SAFETY DEPENDS ON YOU

CLEANING MATERIALS:

Cleaning should be performed according to instructions in this manual, using Break-Free® CLP or equivalent cleaner.

Use the cleaning kit that has been provided or cleaning equipment designed to clean M4 or M16 firearms. The cleaning kit should contain, a good quality gun oil, cleaning rods, bore patches, small brush, a bore brush, and a chamber brush at a minimum.

CLEANING PROCEDURE:

WHEN TO CLEAN:

After Firing- Clean your firearm as soon as possible, this will lessen the opportunity for corrosion to start.

Periodically- We suggest you clean your firearm when necessary and at least once or twice a year in a temperate climate, or as often as once a week in a tropical climate. If you get your firearm wet, clean it as soon as possible.

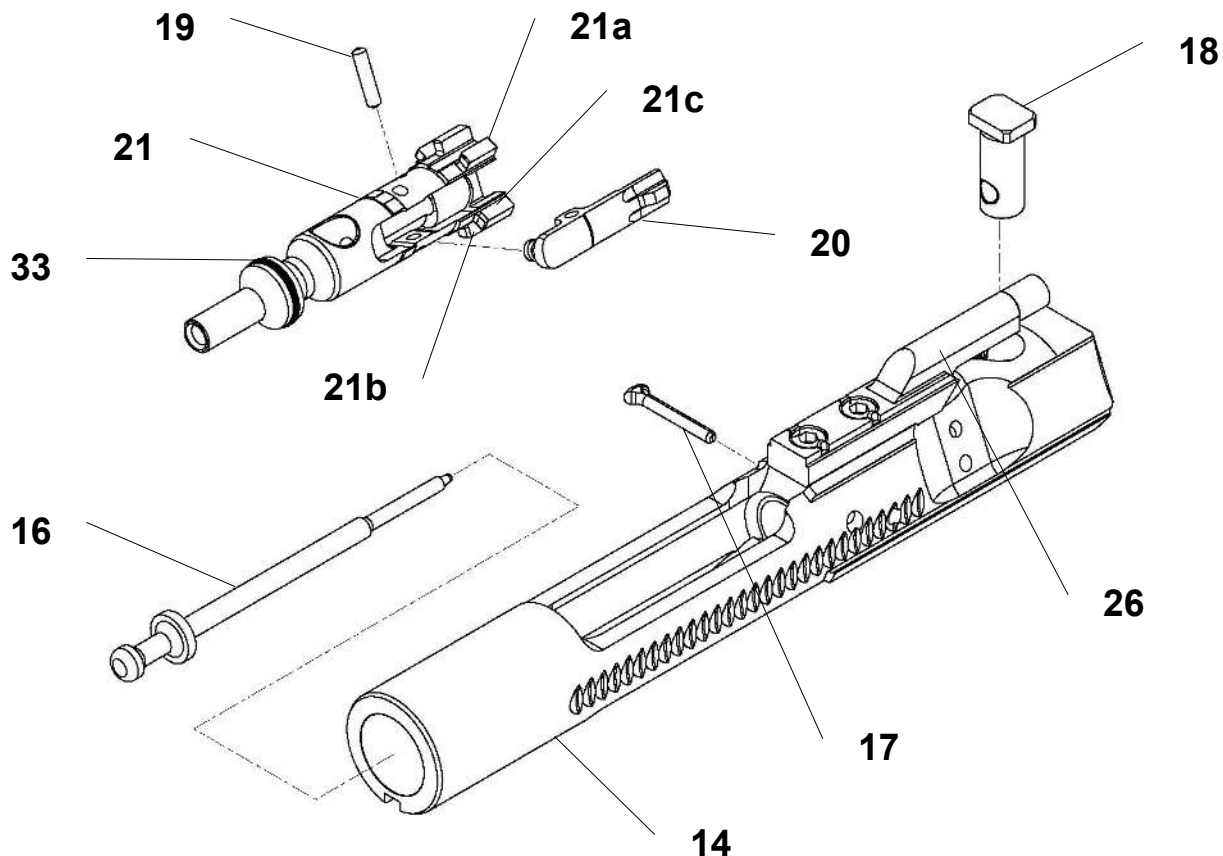

SAFETY DEPENDS ON YOU

CLEANING PROCEDURE (Cont.)

1. Use brush to clean the bolt (21). Also clean the following parts:

Rear and face of bolt lugs (21a & 21b)

Locking lugs (21c)

Face of extractor (20)

Firing Pin (16)

Note: Do not attempt to remove heat discoloration from bolt carrier.

2. Install patch on patch holder and wet with bore cleaner. Clean bolt carrier (14) inside and out.

3. Use clean cloth to wipe bolt (21) and bolt carrier (14) clean and dry.

4. Wet chamber brush with bore cleaner and push brush into chamber and rotate several times to clean chamber. Then pull brush straight through chamber several times to clean between locking lugs. Wipe the parts clean and dry with a clean cloth.

5. Push brush through entire length of bore from chamber end (15) towards muzzle end of barrel (70).

6. Repeat previous step three times.

7. Install clean patch on patch holder and insert into bore from chamber end.

8. Pull patch through entire length of bore.

9. Install a clean patch in holder and repeat previous step until a patch comes out of the bore clean and dry.

10. Wipe the buffer assembly (23), action spring (24), and lower receiver (32) and remove any dirt.

11. Clean inside of the lower receiver (32) and around its assembled parts.

12. Clean receiver extension tube (31) with a dry cloth.

13. Clean buttstock assembly (12) with a dry cloth.

14. Wipe all surfaces of upper receiver (29), lower receiver (32), and lower rail (62) clean and dry.

SAFETY DEPENDS ON YOU

CLEANING PROCEDURE (Cont.)

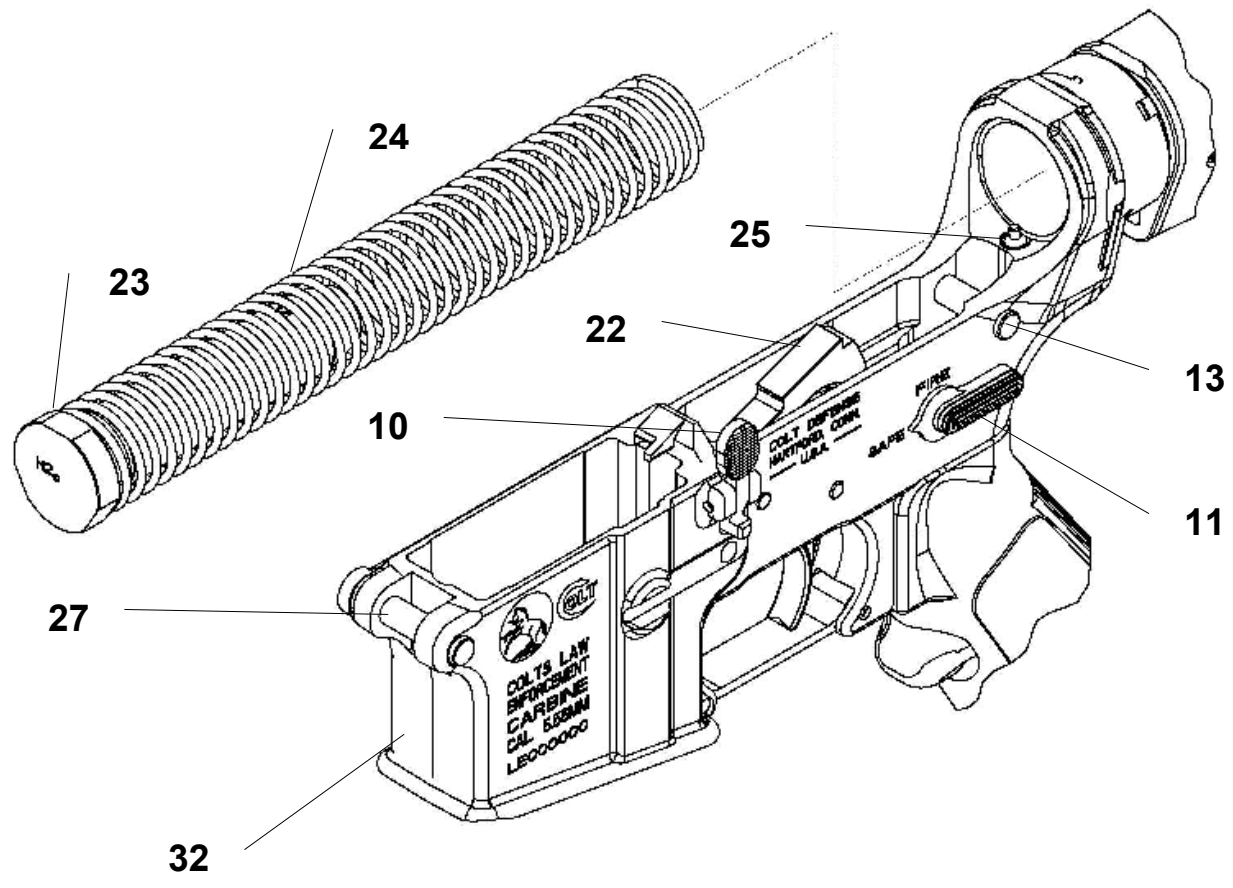
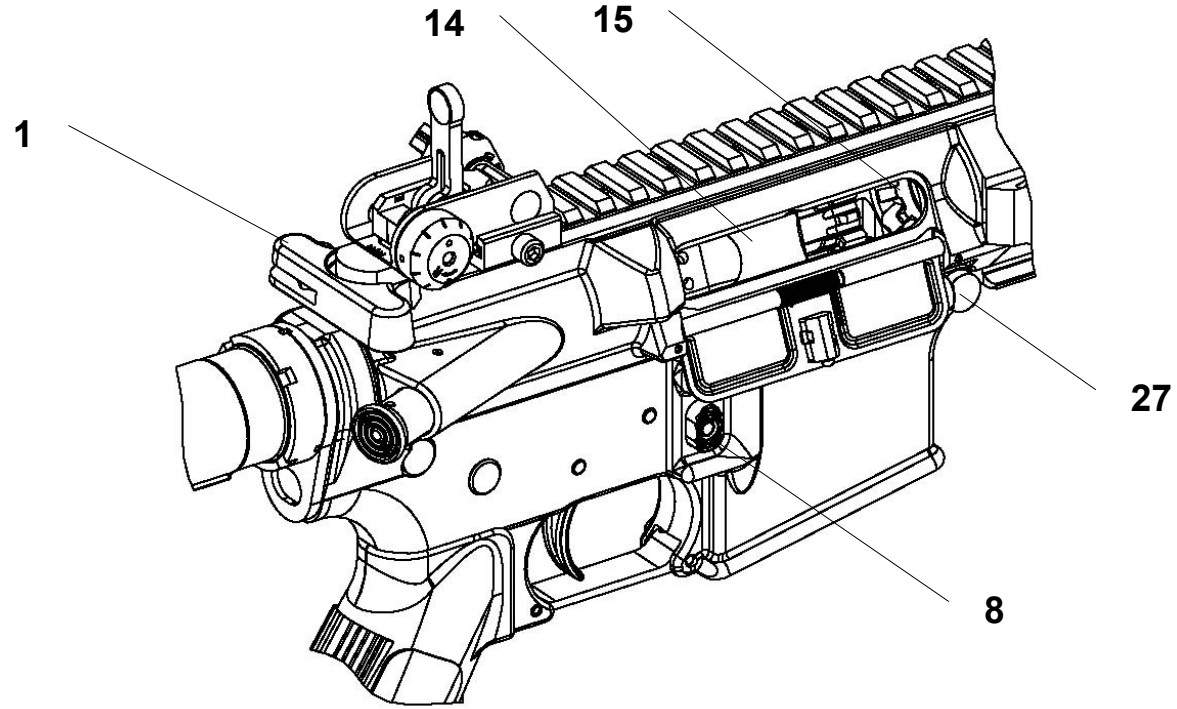

SAFETY DEPENDS ON YOU

LUBRICATION:

Lubrication should be performed according to instructions in this manual, using Break-Free® CLP or equivalent lubricant.

1. Run a lightly oiled patch through the bore. Be sure the chamber (15) remains dry.
2. Wipe one drop of oil on each bolt carrier (14) track.
3. Lightly lubricate inside the upper receiver (29), outer surfaces of the barrel (70) and front sight (4).
4. One drop of lubricant on front sight detent.
5. Place one drop of lubricant in the carrier key (26).
6. Generously lubricate cam pin hole, bolt rings (33) and outside of the bolt body (21) and a light coat on the extractor (20) and pin (19).
7. Lightly lubricate charging handle (1) and inner and outer surfaces of the bolt carrier (14). Generously lubricate sides and cam pin area of bolt carrier.
8. Lightly lubricate inside receiver extension tube (31).
9. Generously lubricate takedown (13) and pivot (27) pins and detents. Also lightly lubricate all moving parts inside the lower receiver (32) and their pivot pins.

SAFETY DEPENDS ON YOU

LUBRICATION (Cont.)

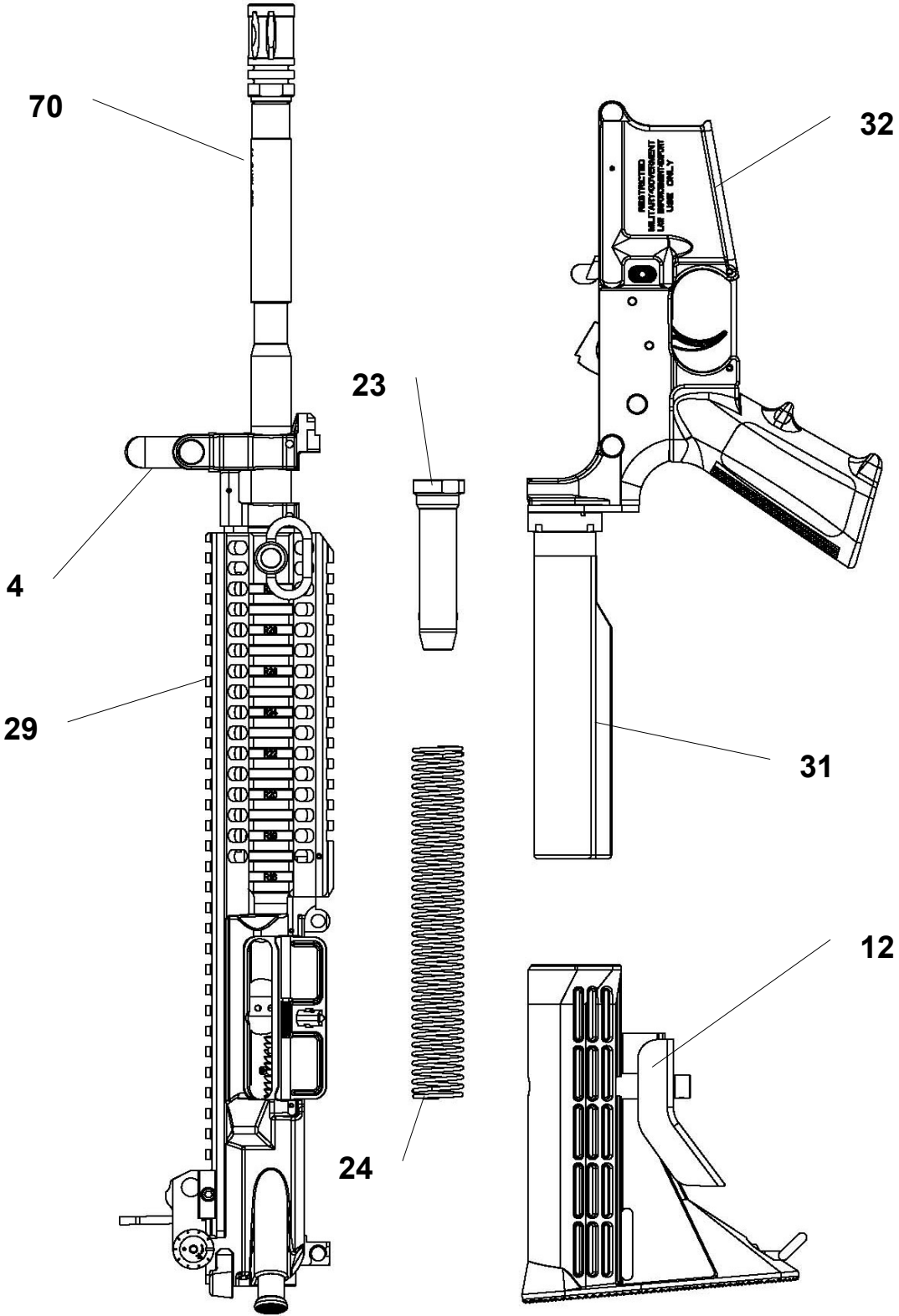

SAFETY DEPENDS ON YOU

ASSEMBLY:

BOLT CARRIER

 **WARNING:** DO NOT ATTEMPT TO FIRE THE CARBINE WITHOUT THE CAM PIN INSTALLED IN THE BOLT GROUP. DOING SO COULD RUPTURE THE CARTRIDGE INSIDE THE CHAMBER, RELEASING HIGH PRESSURED GAS TOWARDS THE SHOOTER, CAUSING DAMAGE TO PROPERTY OR SERIOUS INJURY OR DEATH.

1. To assemble bolt (21), first look at the underside of the extractor (20) and ensure rubber insert (20a) and extractor spring (20b) are in place. They should NOT have been removed from the extractor.
2. While holding extractor assembly (20) in place on bolt (21), insert extractor pin (19) through bolt and extractor.
Note: Stagger gaps on gas rings (33) to prevent gas loss.
3. With bolt (21) oriented to bolt carrier (14), as shown in sketch (Page 27), insert bolt in bolt carrier.
4. With the extractor (20) at the 10 o'clock position, align the cam pin hole in bolt (21) with end of cam slot in carrier furthest offset from carrier key (26).
5. Insert cam pin (18) and rotate $\frac{1}{4}$ turn.
6. Rotate bolt (21) until cam pin (18) is under bolt carrier key.
7. Insert firing pin (16) through rear of bolt carrier (14) and assemble firing pin to bolt (21). Push firing pin fully forward in bolt and install firing pin retaining pin (17).

UPPER RECEIVER

8. Re-install lower rail (62) if removed for cleaning, by inserting tabs into upper receiver (29) and slide the lower rail (62) rearward until it latches with the upper receiver (29).
9. Insert quick detachable sling swivel (52) into either the 9 or 3 o'clock rail of the upper receiver (29).

SAFETY DEPENDS ON YOU

ASSEMBLY (Cont.)

10. Place charging handle (1) in upper receiver (29). Push charging handle forward until three inches from full forward position.
11. Pull the bolt (21) out into the unlocked position (extended). Place the carrier assembly (3) with the carrier key (26) in slot of charging handle (1). Push forward on bolt carrier assembly (3) and charging handle (1) until the bolt fully closes and locks (carrier should be flush with the back of the upper receiver).

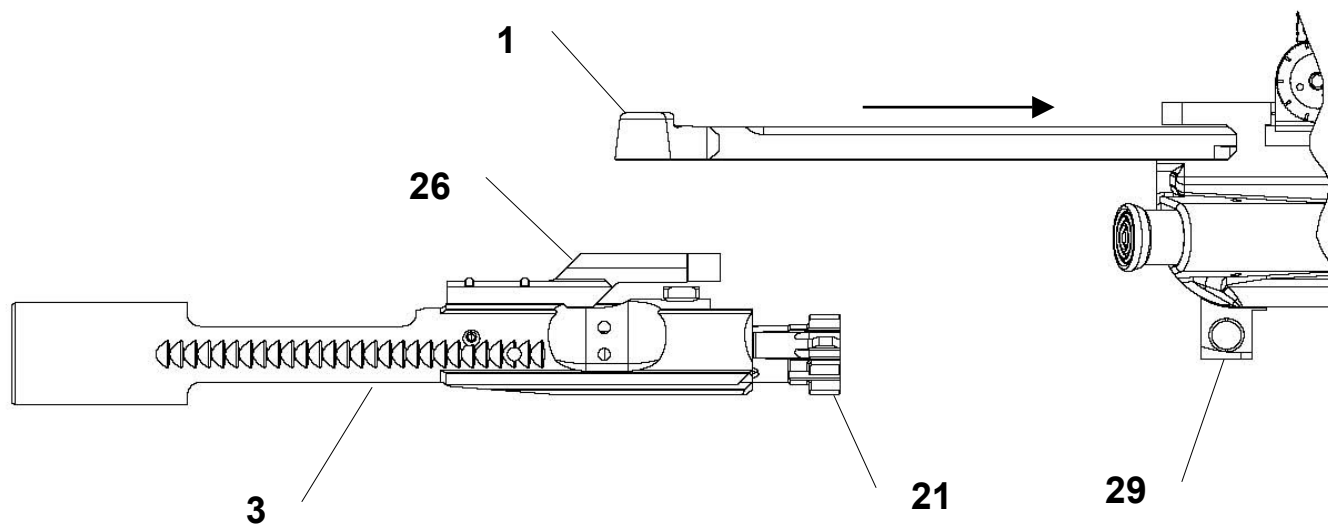
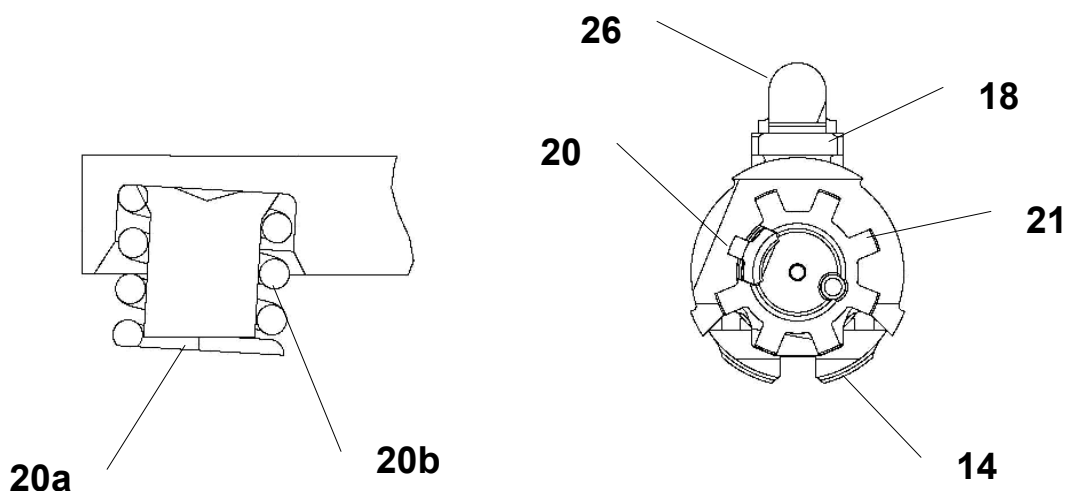

SAFETY DEPENDS ON YOU

ASSEMBLY (Cont.)

LOWER RECEIVER

12. Insert buffer assembly (23) into action spring (24) until the spring snaps onto the collar of the buffer and slide them into lower receiver (32) and receiver extension tube (31). Push buffer inward until buffer retainer (25) snaps up to hold buffer assembly (23) in place.
13. Pull buttstock lever (30) down and slide buttstock assembly (12) onto receiver extension tube (31).

UPPER & LOWER RECEIVERS

14. Rotate hammer (22) rearward until it locks in the cocked position.
15. Rotate selector lever (11) to "SAFE".
16. Assemble upper receiver (29) to lower receiver (32) so that pivot pin holes are aligned. Push pivot pin (27) inward until it is flush with the lower receiver.
17. Close receivers and press takedown pin (13) inward until it is flush with the lower receiver (32).

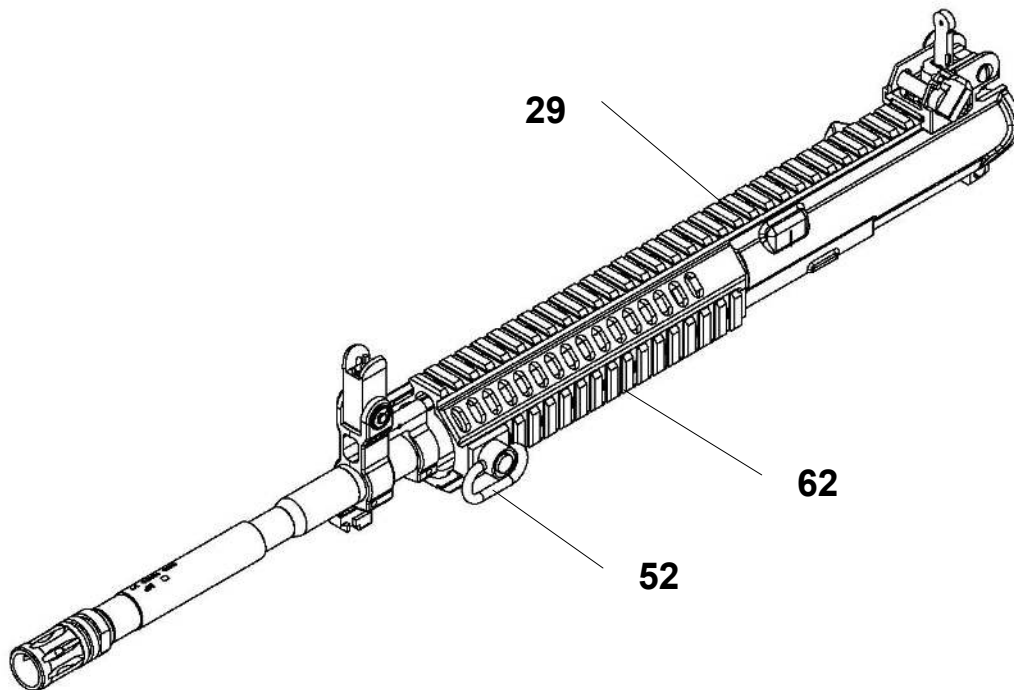

SAFETY DEPENDS ON YOU

ASSEMBLY (Cont.)

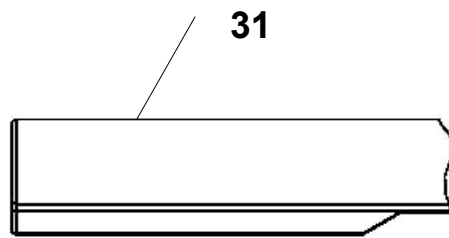
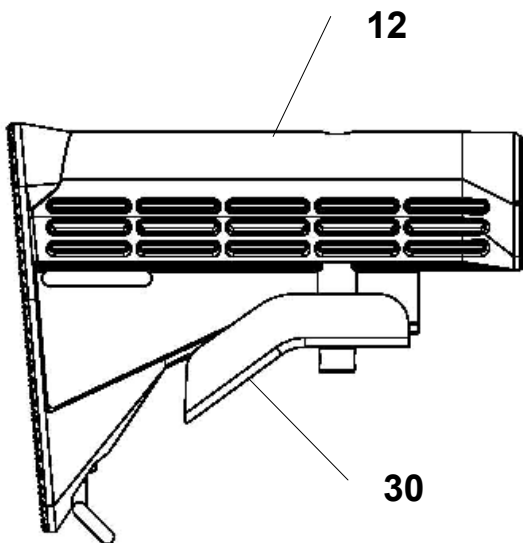
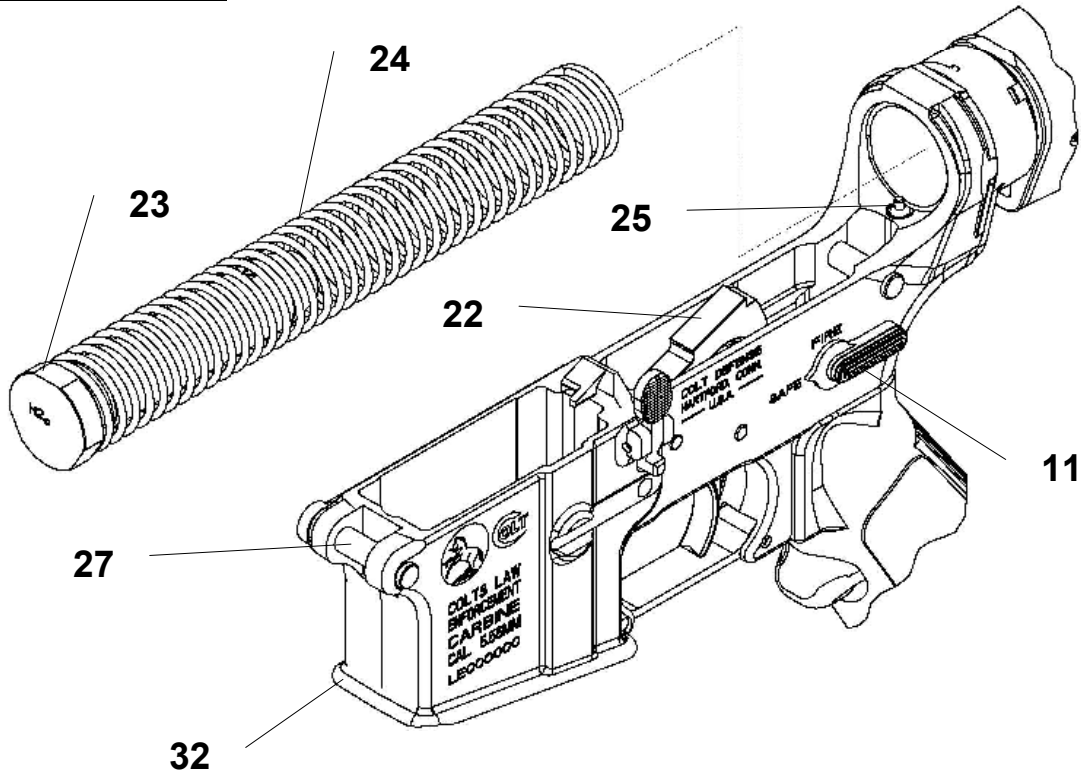

SAFETY DEPENDS ON YOU

ASSEMBLY (Cont.)

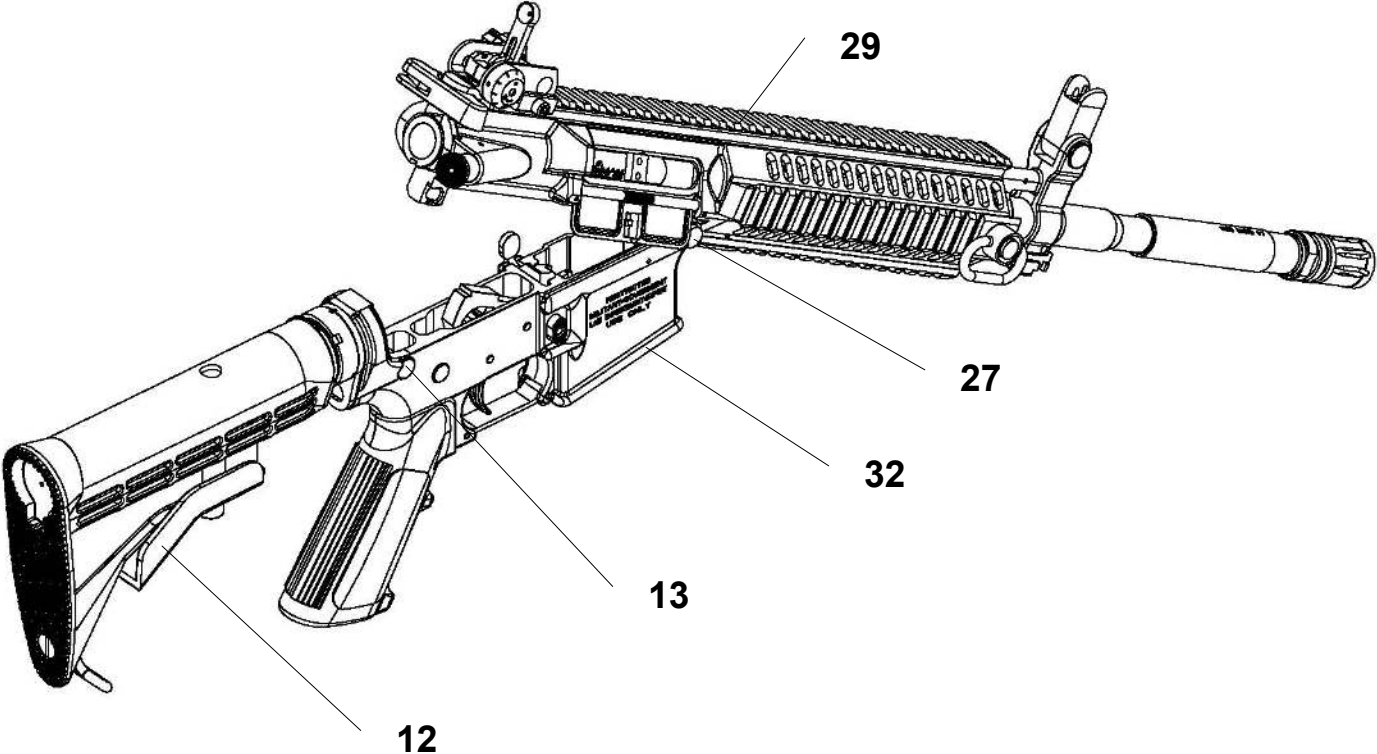

SAFETY DEPENDS ON YOU

ASSEMBLY (Cont.)

REVERSIBLE SELECTOR LEVER- “SEMI-AUTO” Models Only

The selector lever is reversible, for either left or right hand use. As shipped from the factory, the selector lever is installed on the left side of the carbine (when viewed from the rear). The following procedure describes how to disassemble and reinstall the selector lever to the right side of the carbine.

 **WARNING: ALWAYS ENSURE THAT THE FIREARM IS UNLOADED BEFORE DISASSEMBLING. ALWAYS KEEP THE MUZZLE POINTED IN A SAFE DIRECTION. IF THIS FIREARM IS CARELESSLY OR IMPROPERLY HANDLED, AN ACCIDENTAL DISCHARGE COULD RESULT AND COULD CAUSE SERIOUS INJURY, DEATH, OR DAMAGE TO PROPERTY.**

1. Rotate selector (11) to “SAFE” position.
2. Press magazine release button (8) and remove magazine (7).
3. Pull charging handle (1) rearward; check that chamber (15) is empty; release charging handle.
4. Ensure bolt is fully forward, push left end of takedown pin (13) into receiver. Pull pin to right until stopped by detent.
5. Push pivot pin (27) to right and pull out as far as it will go. Separate receivers.
6. Remove pistol grip (25) from lower receiver (32) by removing the pistol grip screw (45) located inside the pistol grip (25). Be careful not to lose the selector detent (46) and selector spring (47).
7. With the selector (11) in the “SAFE” position, cock the hammer (22). This will allow the selector (11) to be removed. If necessary depress the hammer (22) while pulling the selector (11) out.
8. The selector (11) can now be installed into the selector hole on the right side of the carbine. Once the selector (11) is inserted into the hole, rotate the selector (11) so that the indicator point is rotated to the “SAFE” position (pointing towards the front of the carbine)
9. With the selector (11) installed in the “SAFE” position, reinstall the selector detent (46) into the lower receiver (32) and then install the selector spring (47) into the pistol grip (25).
10. Slide the pistol grip (25) onto the lower receiver (32), be careful, do not kink the detent spring (47) when installing the pistol grip (25).
11. Tighten the pistol grip screw (45), minimum torque of 65 in. lbs.
12. Function test the selector (11) as described on [pages 33 & 34](#), to ensure that it functions properly.

SAFETY DEPENDS ON YOU

ASSEMBLY (Cont.)

REVERSIBLE SELECTOR LEVER (Cont.)
“SEMI-AUTO” Models Only

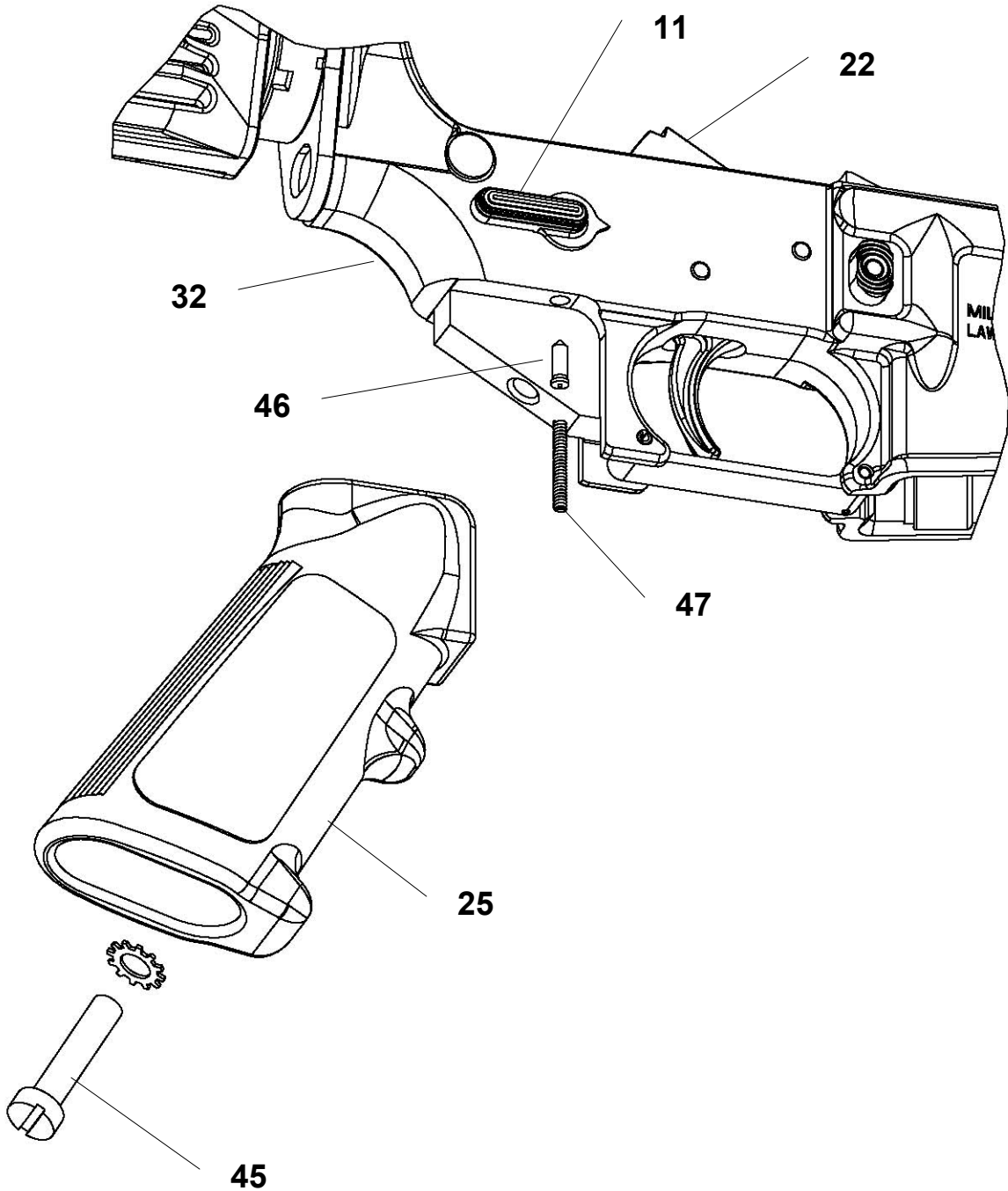

SAFETY DEPENDS ON YOU

FUNCTIONAL CHECKS

 **WARNING:** ALWAYS ENSURE THAT THE FIREARM IS UNLOADED BEFORE PERFORMING FUNCTIONAL CHECKS AND ALWAYS KEEP THE MUZZLE POINTED IN A SAFE DIRECTION. IF THIS FIREARM IS CARELESSLY OR IMPROPERLY HANDLED, AN ACCIDENTAL DISCHARGE COULD RESULT AND COULD CAUSE SERIOUS INJURY, DEATH, OR DAMAGE TO PROPERTY.

The functional checks should always be done after cleaning and assembling the firearm. If the firearm fails any functional check, make sure the firearm is clean and assembled properly. If it still fails, have your firearm examined by a competent gunsmith or return it to Colt for service.

1. **Remove magazine and clear the chamber to ensure carbine is not loaded, as described on [page 15](#) (Actions 1, 2 & 3).**

Checking Selector (SAFE)

2. Pull charging handle (1) to rear and release it.
3. Rotate selector lever (11) to “SAFE”.
4. Pull trigger (36). You should hear nothing, as hammer (22) should not fall. Release trigger (36).

Checking Selector (FIRE OR SEMI)

5. Rotate selector lever (11) to “FIRE” or “SEMI”.
6. Pull and hold trigger (36). You should hear an audible click as hammer (22) falls.
7. Pull charging handle (1) to rear and release it while keeping trigger (36) pulled. Hammer (22) should not fall but be held by the disconnecter (37).
8. Release trigger (36). You should hear a light audible click as hammer (22) is released from the disconnecter (37) and drops part way to engage with trigger.
9. Pull trigger (36). You should hear an audible click as hammer (22) falls.

SAFETY DEPENDS ON YOU

FUNCTIONAL CHECKS (Cont.)

Checking Selector (AUTO)

10. Rotate selector lever (11) to “AUTO”.
11. Pull and hold trigger (36). You should hear a loud click as hammer (22) falls.
12. **Pull charging handle (1) to rear and release it while keeping trigger (36) pulled.**
13. Release trigger (36), no click should be heard.
14. Pull trigger (36), no click should be heard.
15. Pull and release charging handle (1) while keeping trigger (36) pulled.
16. Release trigger (36), no click should be heard.

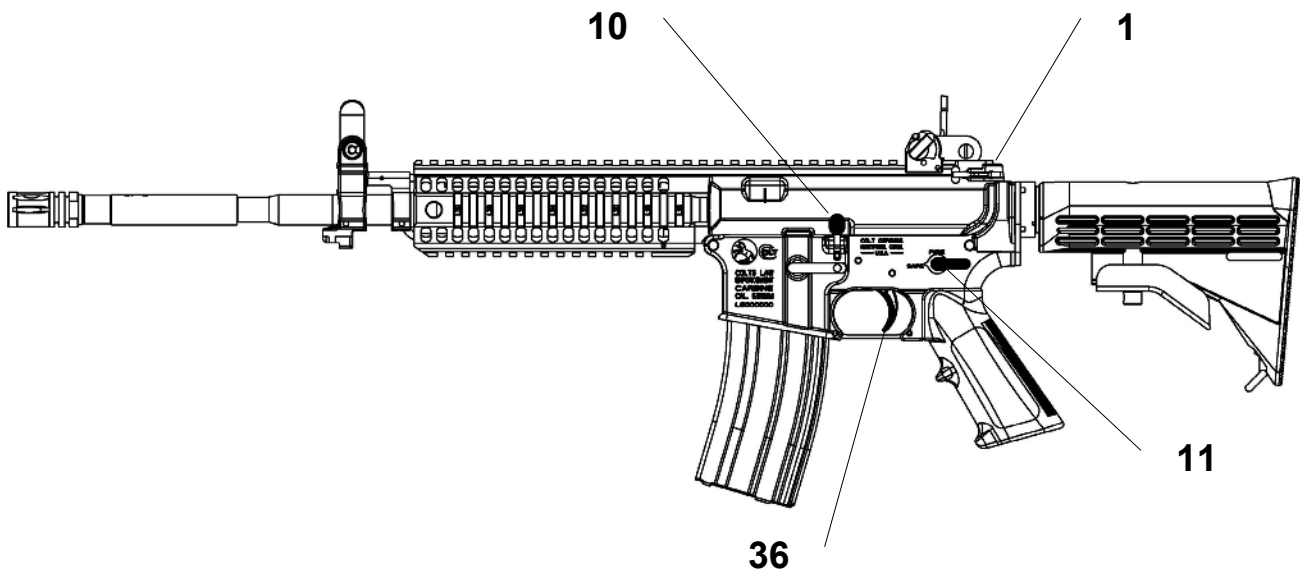

SAFETY DEPENDS ON YOU

FUNCTIONAL CHECKS (Cont.)

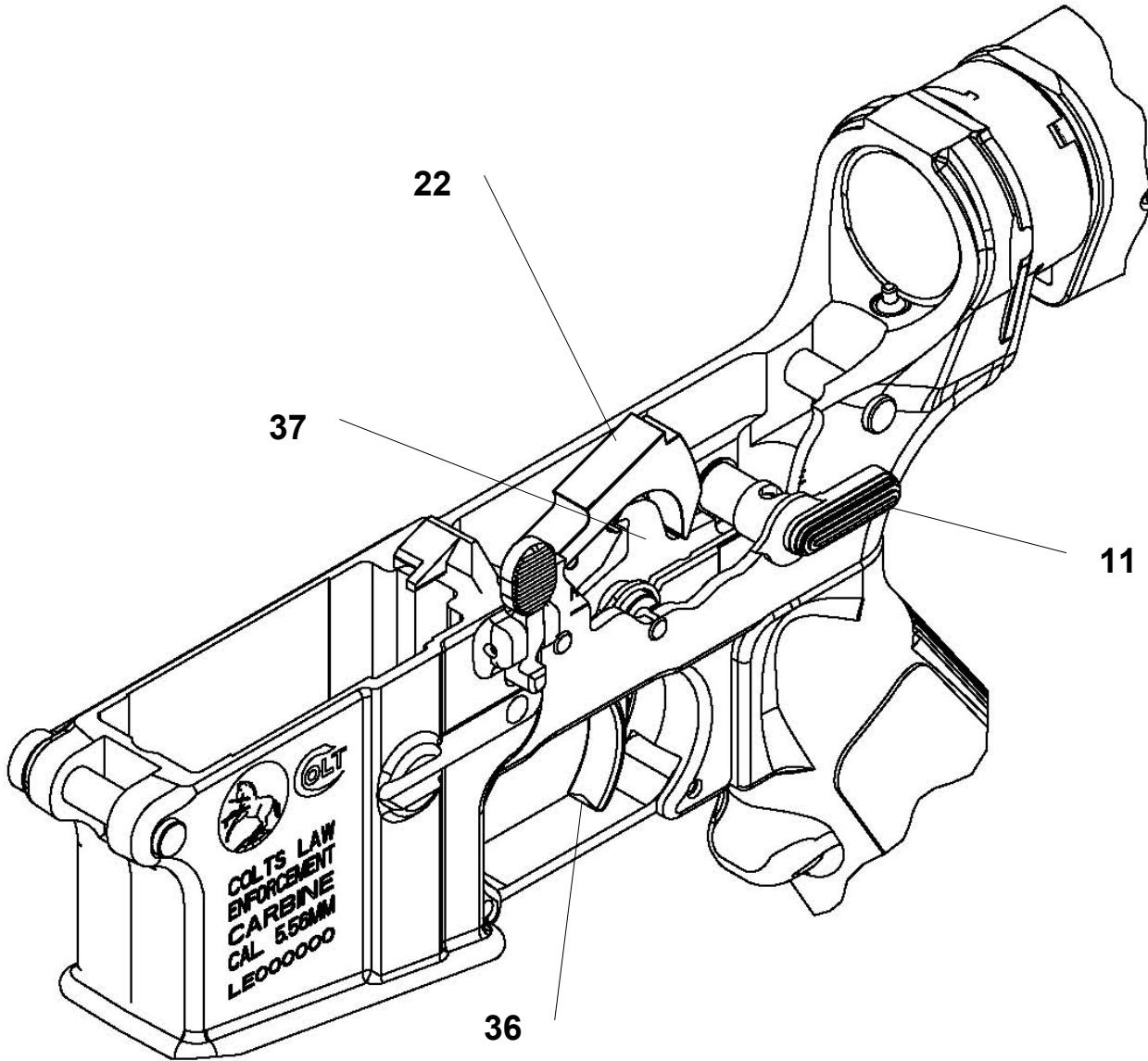

SAFETY DEPENDS ON YOU

FUNCTIONAL CHECKS (Cont.)

Checking Magazine Catch and Bolt Catch

17. Install an empty magazine and check that it is locked in place by the magazine catch (8).
18. With empty magazine installed, rotate fire control selector (11) to "FIRE" or "SEMI".
19. Pull charging handle (1) fully back and then push it forward into locked position. Bolt carrier assembly (3) should be held to the rear by the bolt catch (10).
20. KEEP FINGERS CLEAR OF EJECTION PORT. Push top of bolt catch (10) in to release bolt carrier assembly (3), so that the carrier assembly moves forward into the locked position. Release top of bolt catch (10).
21. Rotate fire control selector (11) to "SAFE".
22. Close ejection port dust cover (6).

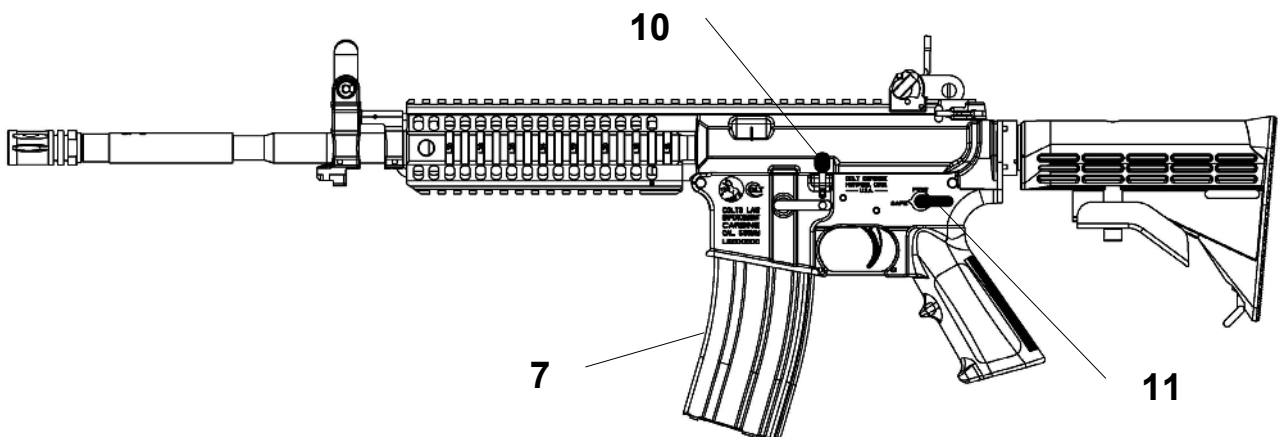
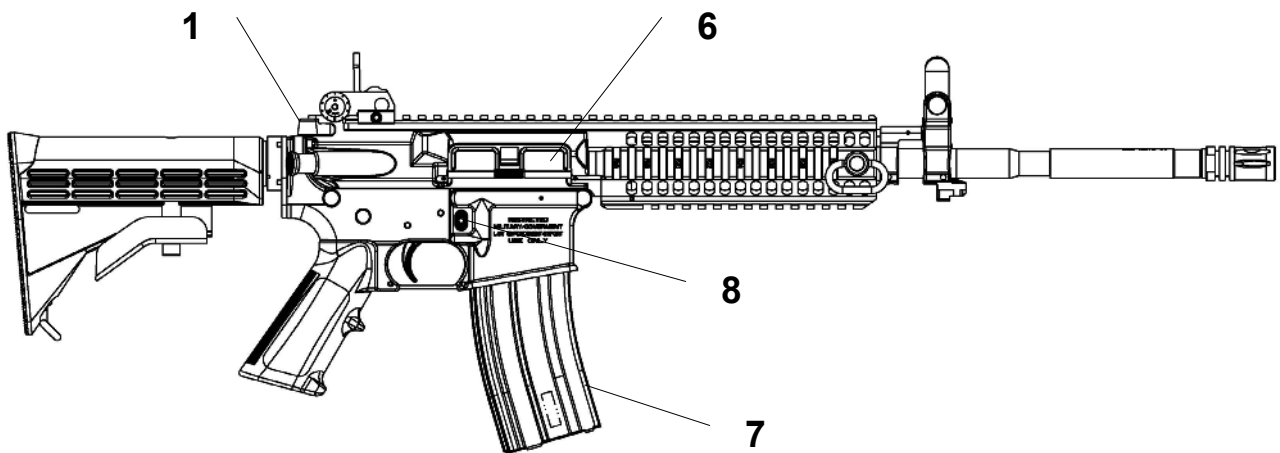

SAFETY DEPENDS ON YOU

MALFUNCTION AND TROUBLESHOOTING

MALFUNCTION

Failure to fire.

PROBABLE CAUSE

1. Selector lever on SAFE.
2. Damaged firing pin.
3. Improper assembly of firing pin in bolt carrier group.
4. Fire control mechanism improperly assembled or with worn, broken or missing parts.
5. Trigger pin improperly installed.

CORRECTIVE ACTION

Rotate selector to "FIRE", "SEMI", or "AUTO"
Replace.

Remove firing pin and install correctly. Inspect retaining pin for damage.

Take or send the firearm to Colt for service.

Take or send the firearm to Colt for service.

Failure to unlock (bolt seizes – will not rotate from locked position).

1. Bolt group, firing pin, or barrel burred, dirty or carbon fouled.

Rotate selector lever (11) to "SAFE". Remove magazine. Hold firearm pointing up (stay clear of muzzle) and strike butt sharply and squarely on ground while pulling back on charging handle.

Remove bolt group, clean and lubricate.



WARNING: MAKE CERTAIN TO BE CLEAR OF THE MUZZLE SO THAT IF THERE IS AN ACCIDENTAL DISCHARGE OF FIREARM, YOU AND OTHERS WILL AVOID INJURY, DEATH OR DAMAGE TO PROPERTY. STRIKE BUTT SQUARELY ON GROUND TO PREVENT DAMAGE TO BUTTSTOCK.

SAFETY DEPENDS ON YOU

MALFUNCTION AND TROUBLESHOOTING (Cont.)

Failure to extract.	1. Dirty or corroded Ammunition.	Remove ammunition from magazine and clean both.
	2. Carbon and dirt build-up in chamber.	Clean chamber.
	3. Carbon and dirt build-up in extractor recess or extractor lip.	Disassemble and clean.
	4. Defective extractor, extractor spring or pin.	Replace.
	5. Rubber insert not assembled in extractor spring.	Replace.
	6. Due to badly pitted chamber.	Take or send the firearm to Colt for service.
	7. Separated cartridge case.	Take or send the firearm to Colt for service.
Failure to eject.	1. Broken ejector.	Take or send the firearm to Colt for Service.
	2. Jammed ejector.	
	3. Weak or broken ejector spring.	See "Short Recoil" in malfunction column.
	4. Short recoil.	

SAFETY DEPENDS ON YOU

MALFUNCTION AND TROUBLESHOOTING (Cont.)

Failure to remain cocked.	1. Worn, broken, or missing parts in fire control mechanism.	Take or send the firearm to Colt for Service.
	2. Hammer pin incorrectly installed.	Remove and install correctly.
Failure to feed.	1. Magazine not seated properly.	Magazine catch may not be properly adjusted. Take or send the firearm to Colt for adjustment.
	2. Dirty or corroded ammunition.	Remove ammunition from magazine and clean both.
	3. Dirty magazine.	Disassemble and clean.
	4. Defective magazine.	Replace.
	5. Too many cartridges in magazine.	Reload.
 CAUTION: Do not load the magazine beyond its rated capacity. Overloading a magazine can damage the feed lips and cause the firearm to malfunction.		
	6. Restricted buffer action.	Remove and clean buffer and action spring.
	7. Short recoil.	See “Short Recoil” in malfunction column.

SAFETY DEPENDS ON YOU

MALFUNCTION AND TROUBLESHOOTING (Cont.)

Double feed.	1. Defective magazine.	Replace magazine.
Failure to chamber.	1. Dirty or corroded ammunition.	Remove ammunition from magazine and clean both.
	2. Restricted movement of bolt carrier group.	Disassemble and thoroughly clean and lubricate the firearm. Remove charging handle from upper receiver, point receiver upward, and install bolt carrier group in receiver. Slowly slide carrier into receiver to check alignment and free movement of carrier. If binding occurs, take or send the firearm to Colt for service.
	3. Bolt cam pin missing.	Replace.
	4. Loose or damaged bolt carrier key.	Take or send the firearm to Colt for service.
	5. Improperly assembled extractor spring.	Check for proper installation.
	6. Damaged ammunition.	Replace.
	7. Carbon build-up in chamber.	Clean chamber.

SAFETY DEPENDS ON YOU

MALFUNCTION AND TROUBLESHOOTING (Cont.)

Failure to lock.

- | | |
|--|---|
| 1. Dirt, corrosion and carbon build-up on bolt or barrel locking lugs. | Clean. |
| 2. Jammed extractor. | Clean and lubricate. |
| 3. Dirt on bolt face. | Clean. |
| 4. Jammed ejector. | Take or send the firearm to Colt for service. |
| 5. Restricted buffer movement. | Remove and clean and lubricate buffer, action spring and inside receiver extension. |
| 6. Damaged ammunition. | Replace. |
| 7. Weak or broken action spring. | Replace. |

Short recoil.

- | | |
|---|---|
| 1. Restricted movement of bolt carrier group or buffer. | See "Failure to Lock" in malfunction column. |
| 2. Missing or loose carrier key. | Take or send the firearm to Colt for service. |

SAFETY DEPENDS ON YOU

MALFUNCTION AND TROUBLESHOOTING (Cont.)

Bolt fails to lock to rear after last shot fired.	1. Dirty or corroded bolt catch. 2. Faulty magazine.	Clean and lubricate. If further disassembly is necessary. Take or send the firearm to Colt for service. Replace.
Fires with selector set on "SAFE".	1. Worn, broken or missing parts in fire control mechanism.	Take or send the firearm to Colt for service.
With selector on "FIRE", fires when trigger is released.	1. Worn, broken or missing part in fire control mechanism.	Take or send the firearm to Colt for service.
Selector lever binds.	1. Lack of cleanliness.	Clean.

Note: Most of the malfunctions noted could also be caused by damaged, faulty or dirty ammunition. Where this is especially likely, a particular note has been included. But in all instances it is good practice to make sure that the ammunition is not the problem before investigating the firearm.

SAFETY DEPENDS ON YOU

MAGAZINE

Standard M4/M16 Aluminum Magazines

The Colt Advanced Law Enforcement Carbines are fully compatible with standard issue M4/M16 magazines.

1. Pry upward on the rear of the magazine floorplate (39) and slide the floorplate off the rear of the magazine body (7).

⚠ WARNING: Spring is under pressure and failure to exercise caution could result in serious injury.

2. Remove magazine spring (40) and follower (41).

Standard 20 Round Magazine

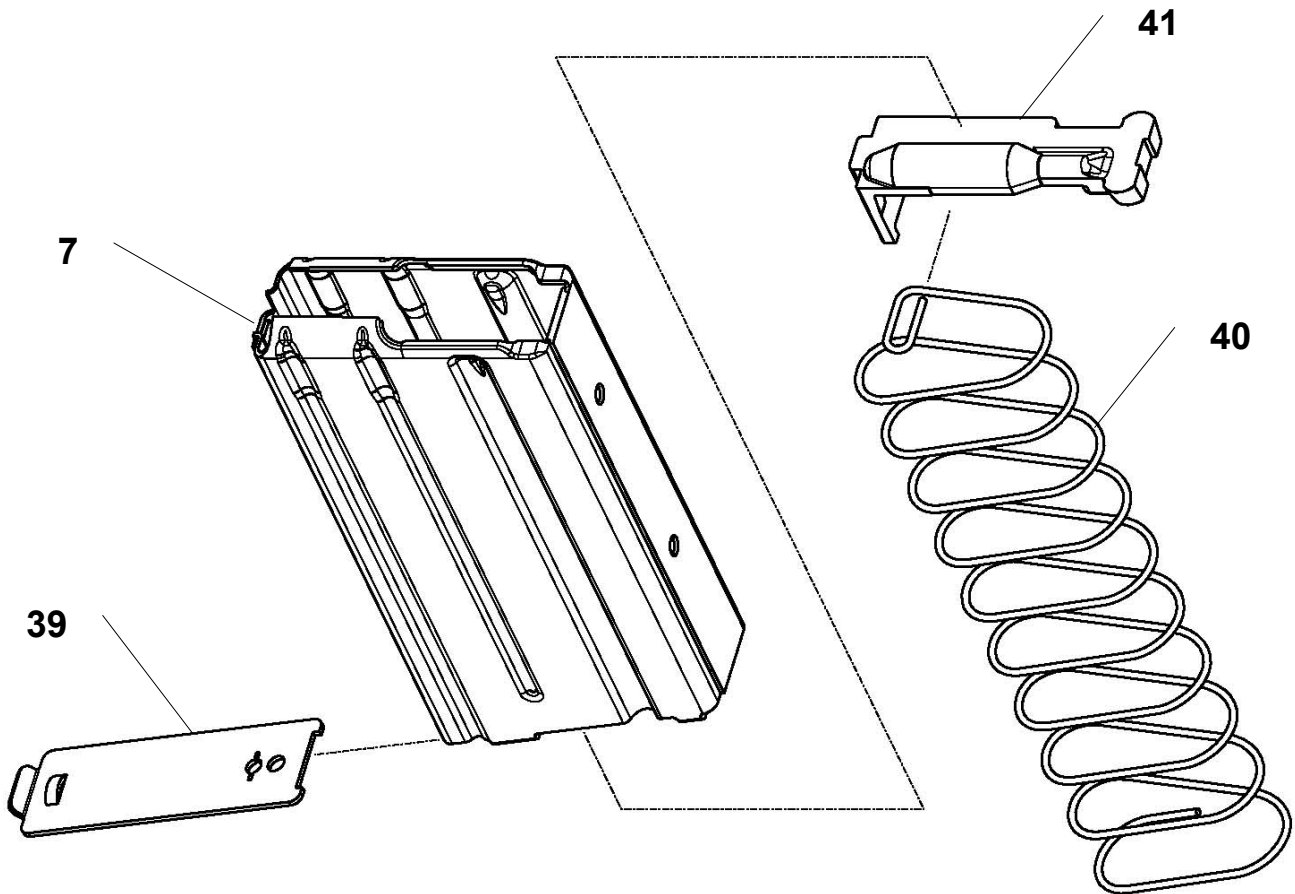

MAGAZINE (Cont.)

Optional 30 Round Magazine

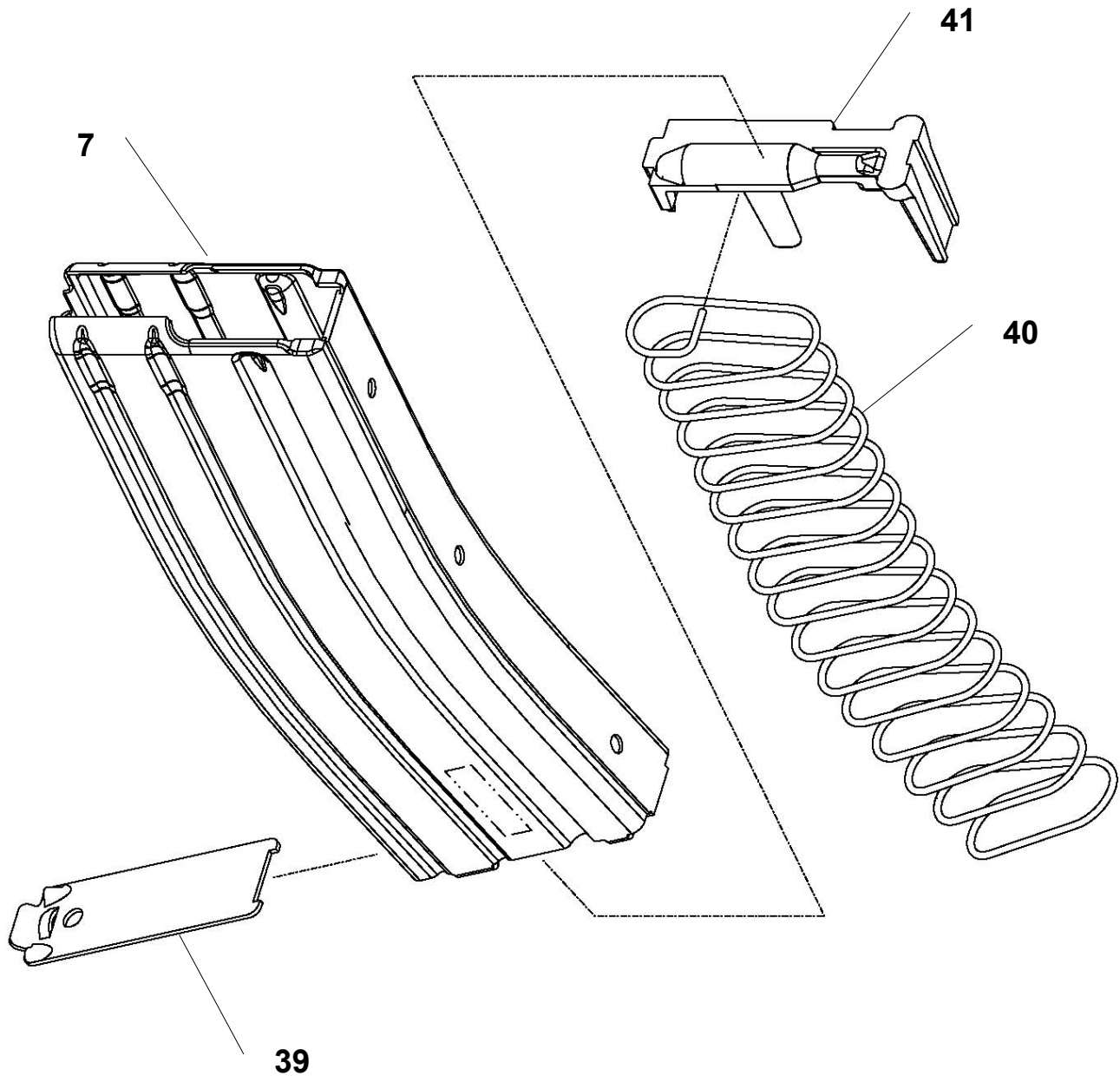

SAFETY DEPENDS ON YOU

OPERATION

FOLDING SIGHTS

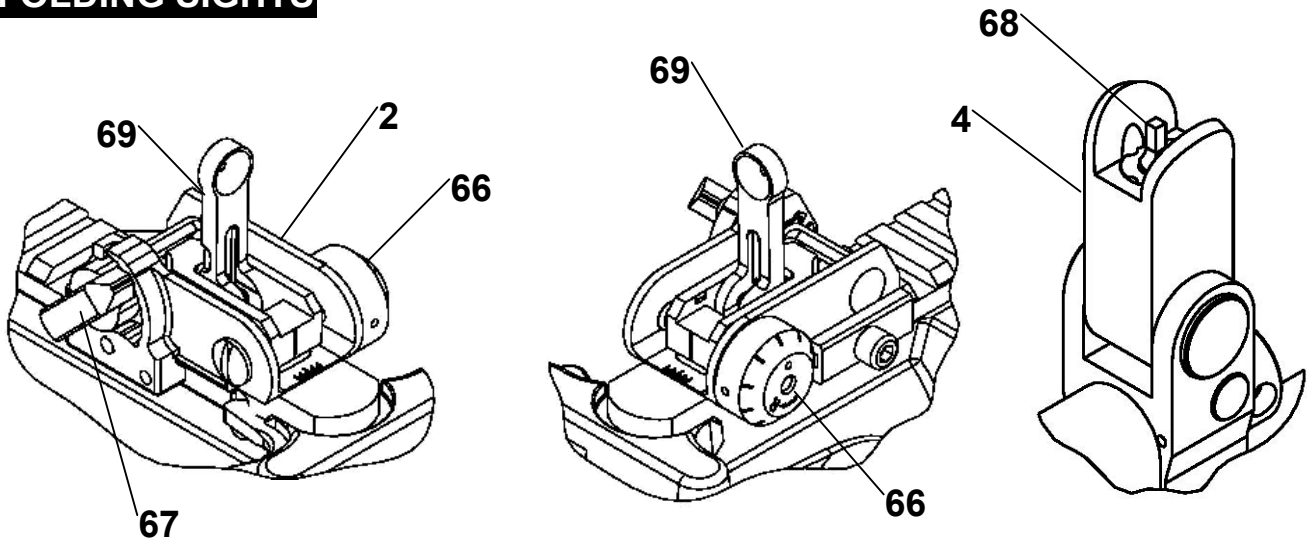

Backup Iron Sight (BUIS)
Adjustable for windage and elevation

Front Sight- Adjustable
for elevation only

1. Rear sight (2) is adjustable for windage (66) and elevation (67). The sight is calibrated to make effective use of M855 ball ammunition.
2. The windage knob (66) is adjustable such that each click moves point of impact horizontally on the target. To move point of impact to right, turn windage knob clockwise; to move point of impact to left, turn windage knob counter-clockwise.
3. The front sight post (68) is adjustable in elevation for zeroing only. It is not used to adjust elevation at any other time. To raise the strike of the bullet, depress the front sight detent and rotate the front sight post clockwise. Reverse the direction of rotation to lower the strike of the bullet.
4. To zero with M855 ammunition, use the M4 25 Meter Zero Target at 25M.
5. The rear aperture (69) should be up and the rear sight should be set at the line below the 300-meter mark. Any changes in elevation will be made with the front sight post (68) during zeroing.

SAFETY DEPENDS ON YOU

FOLDING SIGHTS (Cont.)

6. Aim at the center of the target. Adjust your shot group with the front sight post (68) and rear sight windage knob (66) to hit the white dot in the center of the target. Turn the windage knob counterclockwise in order to move the shot group to the left. Turn clockwise to move the group to the right. When your group is centered, your firearm is zeroed for 300 meters.
7. When zeroing at 10M, set the sights so that M855 groups approximately 5 blocks below the center.

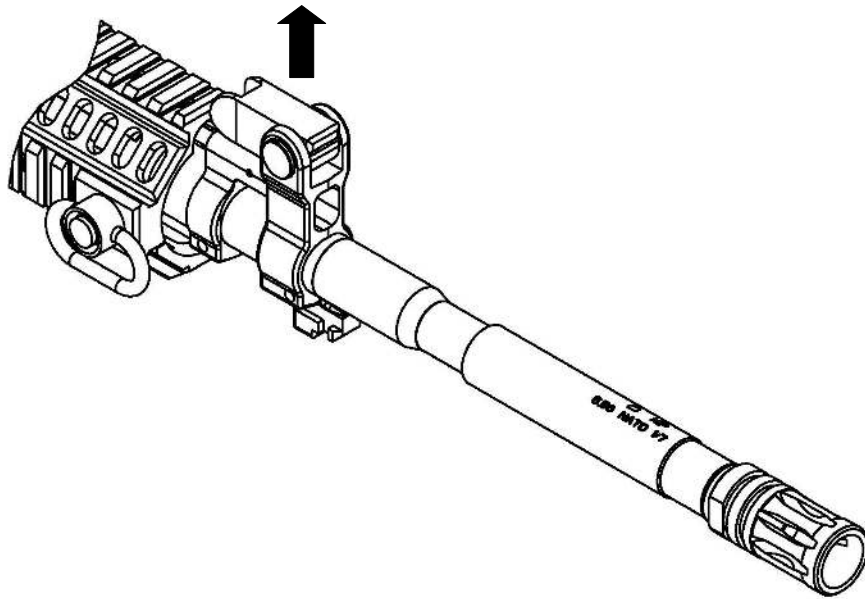

To engage the front sight (4) lift upward on the folding front sight.

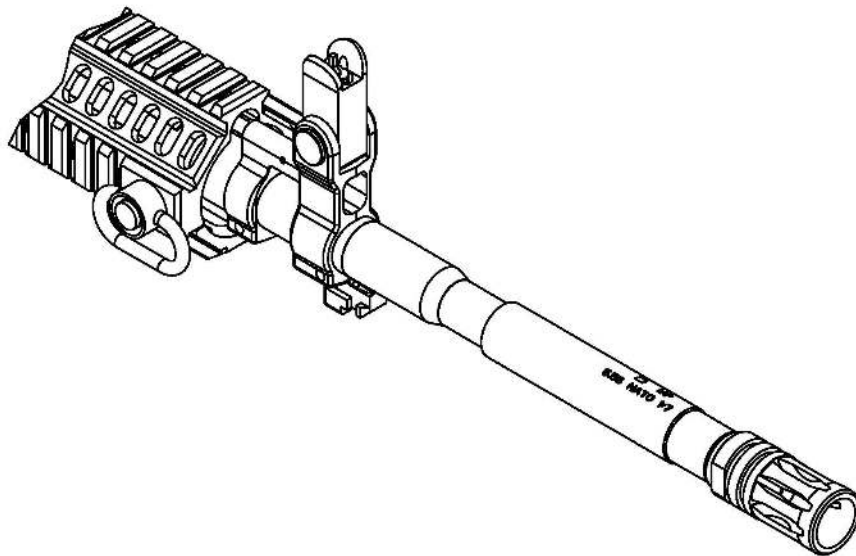

SAFETY DEPENDS ON YOU

OPERATION (Cont.) **LOADING**



1. Place cartridge (61) in magazine (7) and press down.
2. Repeat step 1 until magazine is loaded with required number of cartridges.

 **CAUTION:** DO NOT LOAD MORE CARTRIDGES THAN DESIGNATED INTO THE MAGAZINE. THIS CAN DAMAGE THE MAGAZINE FEED LIPS AND CAUSE THE FIREARM TO MALFUNCTION.

3. Pull charging handle (1) to rear. Push in lower portion of bolt catch (10). Push charging handle forward to latched position.

 **WARNING:** BE SURE FIRE CONTROL SELECTOR (11) IS IN SAFE POSITION PRIOR TO LOADING. IF THIS FIREARM IS CARELESSLY OR IMPROPERLY HANDLED, AN ACCIDENTAL DISCHARGE COULD RESULT AND COULD CAUSE SERIOUS INJURY, DEATH, OR DAMAGE TO PROPERTY.

4. Rotate fire control selector lever (11) to "SAFE".
5. Insert magazine (7) into magazine well (32a) and ensure magazine catch (8) is engaged.
6. Press upper portion of bolt catch (10) to release bolt and chamber cartridge.

 **WARNING:** FIREARM IS NOW LOADED. IF IT IS *NOT* TO BE FIRED, UNLOAD THE FIREARM AS EXPLAINED ON **PAGE 51**. IF THIS FIREARM IS CARELESSLY OR IMPROPERLY HANDLED, UNINTENTIONAL DISCHARGE COULD RESULT AND COULD CAUSE INJURY, DEATH OR DAMAGE TO PROPERTY. (Also see **pages 3 & 4** for more  **WARNINGS**)

 **WARNING:** IF THE BARREL IS VERY HOT FROM FIRING THERE IS A RISK THAT A CARTRIDGE IN THE CHAMBER COULD DISCHARGE BY ABSORBING HEAT FROM THE BARREL ("COOK-OFF"). THIS CAN OCCUR AT ANY TIME. WHEN COOK-OFF IS SUSPECTED, THE CHAMBER MUST BE CLEARED IMMEDIATELY AFTER FIRING. ALWAYS KEEP THE FIREARM POINTED IN A SAFE DIRECTION TO PREVENT SERIOUS INJURY OR DEATH.

SAFETY DEPENDS ON YOU

**OPERATION (Cont.)
LOADING**

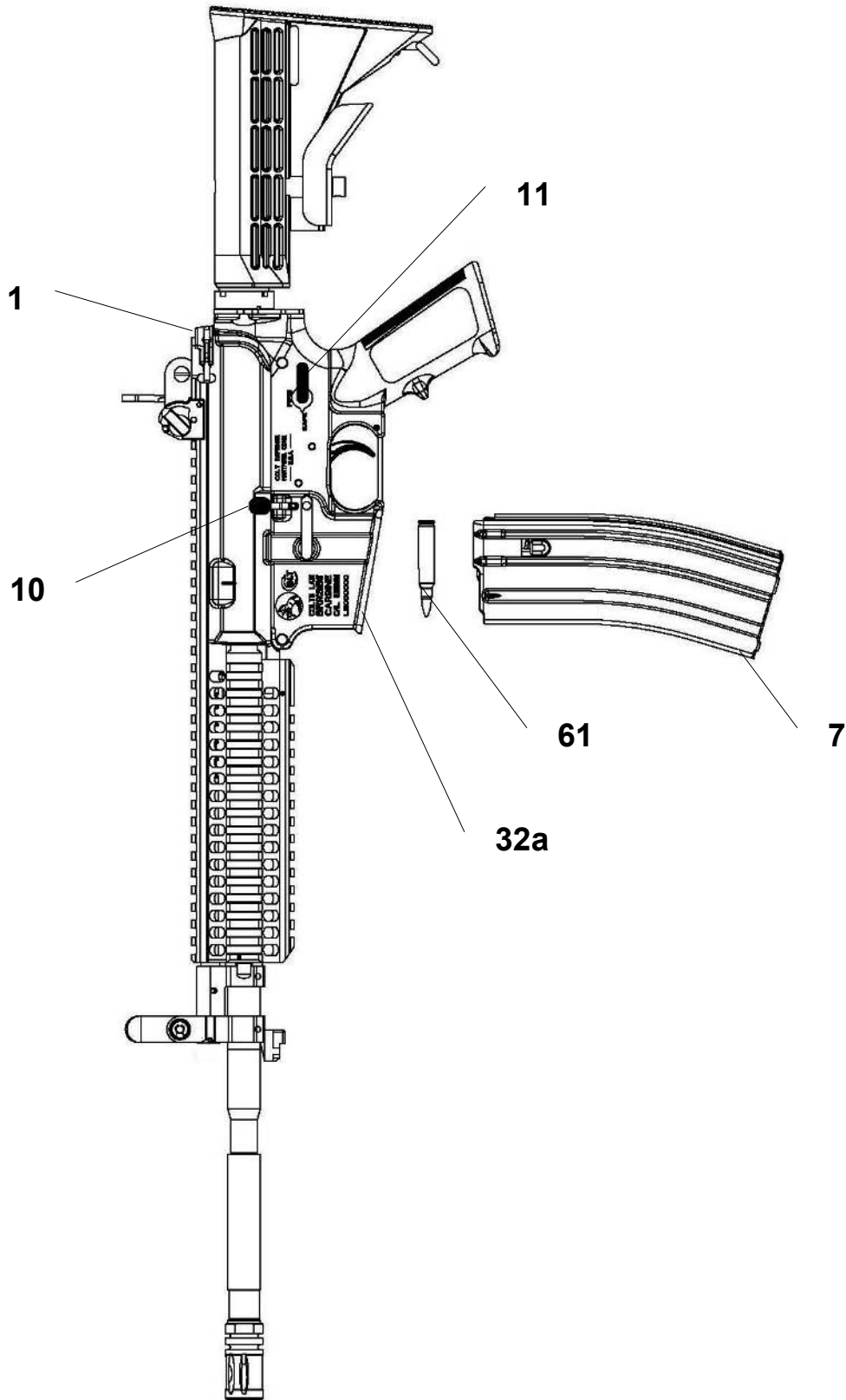

SAFETY DEPENDS ON YOU

OPERATION (Cont.) **AIMING AND FIRING**

 **WARNING:** KEEP FIREARM POINTING IN A SAFE DIRECTION AND LOAD A CARTRIDGE INTO THE CHAMBER. DO NOT TOUCH TRIGGER AND KEEP HANDS AWAY FROM EJECTION PORT WHILE LOADING (See steps 1, 2, 3, but if cartridge is already in chamber, skip to step 4). IF THIS FIREARM IS CARELESSLY OR IMPROPERLY HANDLED, AN ACCIDENTAL DISCHARGE COULD RESULT AND COULD CAUSE SERIOUS INJURY, DEATH, OR DAMAGE TO PROPERTY.

1. Pull charging handle (1) to rear. Press lower portion of bolt catch (10). Push charging handle forward to latched position.
2. Rotate fire control selector lever (11) to “SAFE”.
3. Insert loaded magazine (7) into the magazine well (32A) and push upper portion of bolt catch (10) to release bolt, and chamber a cartridge.

 **WARNING:** FIREARM IS NOW READY TO FIRE. ALWAYS KEEP MUZZLE POINTING IN A SAFE DIRECTION. IF THIS FIREARM IS CARELESSLY OR IMPROPERLY HANDLED, AN ACCIDENTAL DISCHARGE COULD RESULT AND COULD CAUSE SERIOUS INJURY, DEATH, OR DAMAGE TO PROPERTY.

4. Assess range to target and set sights (Sights are described on [pages 45 and 46](#)).
5. Rotate fire control selector lever (11) to “FIRE”, “SEMI”, or “AUTO”.
6. Hold firearm with both hands; one hand on the lower handguard, the other on the pistol grip.
7. Align the target with top of front sight post (68) and center of rear peep sight aperture (69).
8. Pull trigger (36) to fire 1 cartridge when selector is set to “SEMI” or “FIRE” or any number of cartridges on “AUTO” up to the magazine capacity.

 **WARNING:** THIS IS A SEMI-AUTOMATIC FIREARM AND IS IMMEDIATELY LOADED AND READY TO FIRE AFTER EACH SHOT UNTIL THE MAGAZINE IS EMPTY. IF THIS FIREARM IS CARELESSLY OR IMPROPERLY HANDLED, AN ACCIDENTAL DISCHARGE COULD RESULT AND COULD CAUSE SERIOUS INJURY, DEATH, OR DAMAGE TO PROPERTY.

SAFETY DEPENDS ON YOU

OPERATION (Cont.) AIMING AND FIRING

9. Release trigger (36) and rotate fire control selector lever (11) to "SAFE".

⚠ WARNING: IF YOUR FIREARM FAILS TO FIRE, HOLD IT, KEEP IT POINTED IN A SAFE DIRECTION AND REFER TO THE MISFIRE SECTION ON **PAGE 54**. IF THIS FIREARM IS CARELESSLY OR IMPROPERLY HANDLED, AN ACCIDENTAL DISCHARGE COULD RESULT AND COULD CAUSE SERIOUS INJURY, DEATH, OR DAMAGE TO PROPERTY.

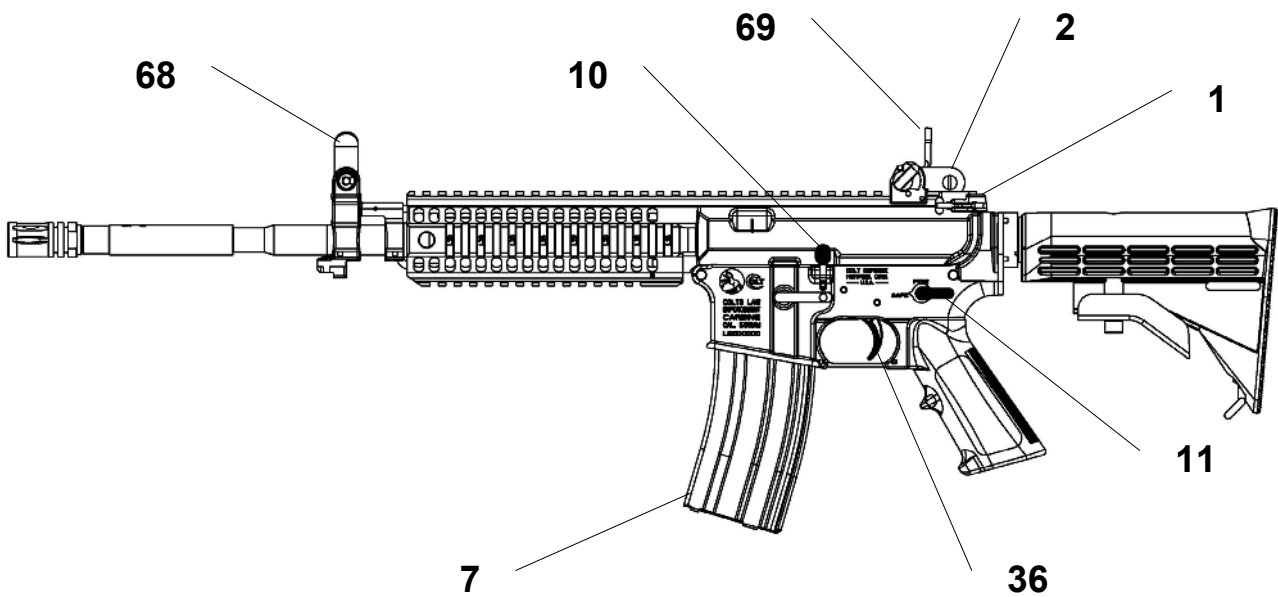

SAFETY DEPENDS ON YOU

OPERATION (Cont.)

UNLOADING

 **WARNING:** ALWAYS KEEP MUZZLE POINTING IN A SAFE DIRECTION. IF THIS FIREARM IS CARELESSLY OR IMPROPERLY HANDLED, AN ACCIDENTAL DISCHARGE COULD RESULT AND COULD CAUSE SERIOUS INJURY, DEATH, OR DAMAGE TO PROPERTY.

 **WARNING:** ALWAYS UNLOAD YOUR FIREARM IMMEDIATELY AFTER USE AND PRIOR TO CLEANING AND STORAGE TO MINIMIZE THE RISK OF ACCIDENTAL DISCHARGE. IF THIS FIREARM IS CARELESSLY OR IMPROPERLY HANDLED, AN ACCIDENTAL DISCHARGE COULD RESULT AND COULD CAUSE SERIOUS INJURY, DEATH, OR DAMAGE TO PROPERTY.

1. Rotate fire control selector lever (11) to “SAFE” and keep firearm pointing in a safe direction.
2. Press magazine catch (8) and remove magazine (7).
3. Pull charging handle (1) to rear. Check that cartridge is ejected from chamber (15).
4. While holding charging handle to rear, push in lower portion of bolt catch (10). Push charging handle forward into the latched position.

 **WARNING:** FIREARM IS CLEAR ONLY WHEN CHAMBER (15) IS EMPTY, MAGAZINE (7) REMOVED, BOLT CARRIER (3) IS LOCKED TO THE REAR AND FIRE CONTROL SELECTOR LEVER (11) IS IN THE “SAFE” POSITION. IF THIS FIREARM IS CARELESSLY OR IMPROPERLY HANDLED, AN ACCIDENTAL DISCHARGE COULD RESULT AND COULD CAUSE SERIOUS INJURY, DEATH, OR DAMAGE TO PROPERTY.

Note: If cartridge is not ejected, ensure barrel is cool to avoid risk from cook-offs, then proceed as follows:

1. Pull charging handle (1) to rear. While holding charging handle to rear, push in lower portion of bolt catch (10). Push charging handle forward to latched position.
2. Insert a cleaning rod through the compensator (5) into the chamber (15) and tap the cartridge out.
3. Cartridge should NOT be used again because it may be damaged, and should be disposed of properly.

SAFETY DEPENDS ON YOU

UNLOADING (Cont.)

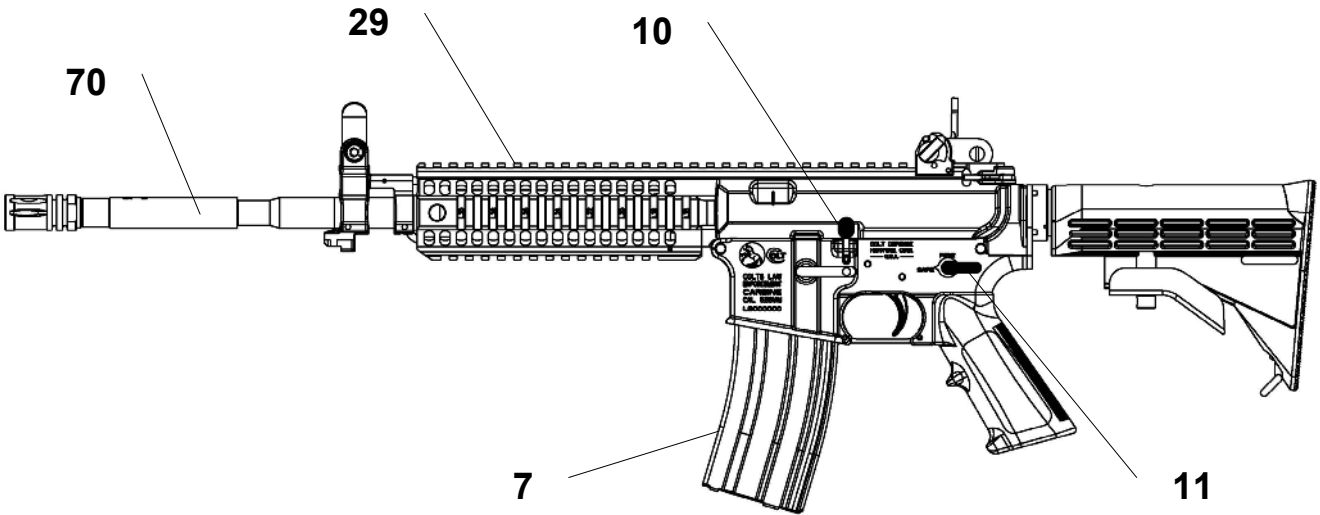
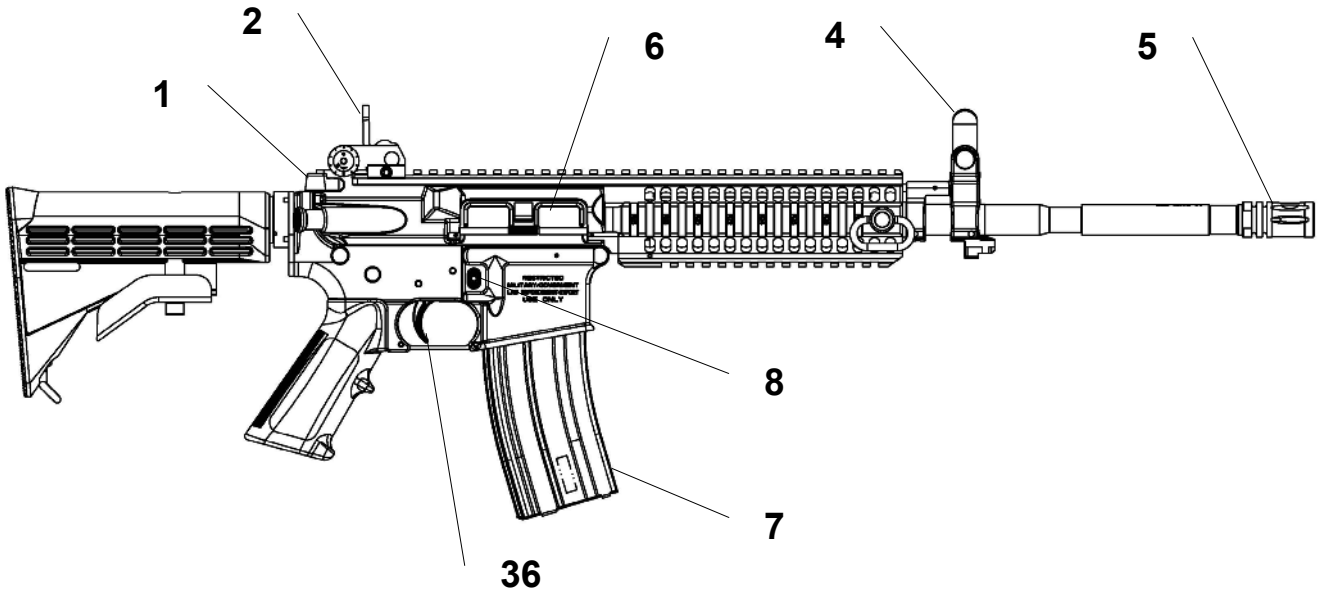

SAFETY DEPENDS ON YOU

OPERATION (Cont.)

STOPPAGE and IMMEDIATE ACTIONS

 **WARNING:** ALWAYS KEEP THE MUZZLE POINTED IN A SAFE DIRECTION. IF THIS FIREARM IS CARELESSLY OR IMPROPERLY HANDLED, AN ACCIDENTAL DISCHARGE COULD RESULT AND COULD CAUSE SERIOUS INJURY, DEATH, OR DAMAGE TO PROPERTY.

 **WARNING:** NEVER USE YOUR FIREARM IF IT FAILS TO FUNCTION PROPERLY AND NEVER FORCE A JAMMED ACTION, AS A ROUND MAY EXPLODE CAUSING SERIOUS INJURY, POSSIBLE DEATH, OR SEVERE DAMAGE TO YOUR FIREARM.

Stoppage – a stoppage is any unintentional interruption of firing.

Immediate Action – immediate action is the action taken as rapidly as possible to correct a stoppage without analyzing the cause. Immediate action is as follows:

1. Tap upward on the bottom of the magazine (7) to be sure it is locked in position. Pull charging handle (1) fully and sharply to the rear. Watch for ejection of a fired or unfired cartridge.
2. If a cartridge or case is ejected, release the charging handle (1) sharply to chamber a new cartridge (do not “ride” the charging handle as it goes forward.)
3. Strike forward assist (9) to ensure bolt carrier (3) closure.
4. Attempt to fire. If firearm fails to fire, inspect to determine the cause of the malfunction and take appropriate action. Refer to the Malfunctions and Troubleshooting section on [pages 37-42](#).
5. If a cartridge or case is not ejected, check to see if there is a cartridge in the chamber. If the chamber is clear, release the charging handle to feed a new cartridge and attempt to fire. If the firearm still fails to fire, refer to the Malfunction and Troubleshooting section.
6. If a cartridge or case is seen in the chamber, and the barrel is cool or just warm, the cartridge or case should be removed as explained on [page 51](#).

 **WARNING:** SEE DANGEROUS SITUATIONS ON [PAGES 54-56](#) FOR EMERGENCY ACTIONS.

SAFETY DEPENDS ON YOU

OPERATION (Cont.)

DANGEROUS SITUATIONS

 **WARNING:** A COOK-OFF CAN OCCUR ANY TIME AFTER CHAMBERING A CARTRIDGE IN A VERY HOT BARREL, SO ALWAYS KEEP THE MUZZLE POINTED IN A SAFE DIRECTION. IF THIS FIREARM IS CARELESSLY OR IMPROPERLY HANDLED, AN ACCIDENTAL DISCHARGE COULD RESULT AND COULD CAUSE SERIOUS INJURY, DEATH, OR DAMAGE TO PROPERTY.

Misfires and Cook-offs

Although misfires are rarely encountered with properly maintained firearms and clean ammunition, misfires and cook-offs are potentially dangerous, particularly if a heavy firing schedule is being followed. It is important that proper corrective action be taken rapidly.

Misfire – A misfire is a failure to fire when the hammer falls due to mechanism malfunction or faulty cartridge. Keep muzzle pointed in a safe direction for 2 minutes with the bolt closed. This will avoid having the cartridge explode due to a slow burning primer when ejected, preventing injury or possible death. If the barrel is hot, see cool-off procedure on [page 55 notes 6 and 7](#). Unload the firearm as previously described in this manual. Examine the unfired cartridge, if the firing pin indent appears normal assume the misfire is the result of faulty ammunition, reload and carry on firing. If the firing pin indent is light, misaligned or nonexistent, load another cartridge and fire the firearm, if another misfire occurs, have your firearm examined by a competent gunsmith or return it to Colt for service.

NOTE: It is normal for a light firing pin indent to appear on the primer of cartridges that have been fed into the chamber of the firearm but not fired.

NOTE: Dispose of the misfired cartridges in accordance with the ammunition manufacturer's instructions.

Cook-Off- A cook-off is accidental firing of a chambered cartridge caused by the cartridge absorbing excess heat from a very hot barrel. The live cartridge may have failed to eject when clearing the firearm, or it may have been fed into the chamber ready for the next shot. It may also remain in the chamber if it misfired or failed to fire. For whatever reason, if a live cartridge remains in the chamber when the barrel is very hot there is a risk of accidental discharge.

SAFETY DEPENDS ON YOU

DANGEROUS SITUATIONS (Cont.)

Cook-Off (Cont.)

Immediate Action – To prevent damage or injury from a cook-off when barrel becomes very hot complete the following actions immediately.

1. Remove magazine (7).
2. Pull charging handle (1) fully rearward. If chamber (15) is empty, lock action open by pressing in bottom of bolt catch (10). If cartridge remains in chamber, skip step 3.
3. Allow barrel to cool for 15 minutes.
4. If cartridge remains in chamber, release charging handle, allow bolt to move forward.
5. Fire cartridge if safe to do so. If not safe, see step 6.
6. If not safe to fire – lay the firearm on the ground pointing in a safe direction with ejection port toward the ground, and step back.
7. Stand clear, and wait 15 minutes for barrel to cool.

 **WARNING: COOK-OFF COULD OCCUR DURING THIS COOLING PERIOD. ALWAYS KEEP THE MUZZLE POINTED IN A SAFE DIRECTION. IF THIS FIREARM IS CARELESSLY OR IMPROPERLY HANDLED, AN ACCIDENTAL DISCHARGE COULD RESULT AND COULD CAUSE SERIOUS INJURY, DEATH, OR DAMAGE TO PROPERTY.**

After barrel is cool, remove cartridge from chamber, then have the firearm examined by a competent gunsmith or return it to Colt for service.

NOTE: Dispose of the unfired cartridges in accordance with the ammunition manufacturer's instructions.

SAFETY DEPENDS ON YOU

DANGEROUS SITUATIONS (Cont.)

Bore Obstructions

 **WARNING:** SNOW, MUD, SAND OR OTHER OBSTRUCTION MUST BE REMOVED FROM THE BARREL BORE BEFORE FIRING. If you attempt to fire with an obstruction in the barrel, it may BULGE or BURST THE BARREL AND COULD CAUSE SERIOUS INJURY, DEATH, OR DAMAGE TO PROPERTY.

1. To remove water from the barrel (70), hold the carbine muzzle down, pull the charging handle (1) to the rear about one half (.500) inch, (1.2cm) to vent the barrel and at the same time shake the weapon vigorously.
2. Release charging handle (1).
3. The weapon can now be fired.

Note: Clean and lubricate the weapon as soon as possible after clearing any obstruction, or whenever it has been exposed to water.

Bullet in Barrel

If a noticeable difference in sound or recoil is experienced or if there is any reason to suspect that a bullet is stuck in the barrel, immediately unload the firearm and look through the bore, not just in the chamber. A bullet may be lodged down the barrel that cannot be easily seen. If a bullet is stuck in the barrel, bring the firearm to a competent gunsmith to dislodge the bullet.

 **WARNING:** IF A BULLET IS STUCK IN THE BARREL, DO NOT ATTEMPT TO SHOOT IT OUT BY USING ANOTHER CARTRIDGE, OR BY BLOWING IT OUT WITH A BLANK, AS DOING SO COULD GENERATE EXCESS PRESSURE, CAUSE DAMAGE TO THE FIREARM, OR CAUSE SERIOUS PERSONAL INJURY OR DEATH.

HEALTH AND ENVIRONMENTAL

 **WARNING:** DISCHARGING OR CLEANING FIREARMS OR HANDLING AMMUNITION IN POORLY VENTILATED AREAS, MAY RESULT IN EXPOSURE TO LEAD AND OTHER SUBSTANCES KNOWN TO CAUSE BIRTH DEFECTS, REPRODUCTIVE HARM, CANCER, AND OTHER SERIOUS PHYSICAL INJURY. HAVE ADEQUATE VENTILATION AT ALL TIMES. CLEAN HANDS THOROUGHLY AFTER EXPOSURE.

SAFETY DEPENDS ON YOU

STORAGE

 **CAUTION: MAKE SURE THE FIREARM IS UNLOADED BEFORE STORING AND STORE AMMUNITION SEPARATELY**

Store your firearm and ammunition securely locked in separate locations out of reach and sight of children and untrained persons, to minimize the risk that the firearm will be used by unauthorized persons.

NOTE: Various Federal and State laws and local ordinances may govern the proper storage of firearms, so take the advice of a Dealer in you state on how to store your firearm.

FIREARMS RECORD

Colt Model Number _____

Serial Number _____

Caliber _____

Purchased From _____

Date Purchased _____

LIMITED LIFETIME SERVICE AGREEMENT

Colt will repair any factory defective part(s) of your Colt firearm, but cosmetic corrections and grip replacement will be made only during the first year. This agreement will not apply to your Colt firearm when it is altered, abused, willfully damaged or damaged by overpressure ammunition. Moreover, this agreement will not apply to those parts of your Colt firearm that have been “tuned” or “gunsmithed” for performance, other than customized tuning and other services provided by Colt Custom Gun Shop, owned and operated by Colt’s Manufacturing Company LLC. This agreement is not transferable, its benefits apply to only the original retail purchaser and it applies only to firearms manufactured after 1996.

SAFETY DEPENDS ON YOU

SERVICING AND REPAIR

Should your firearm require adjustment or repair, make sure it is **NOT LOADED** and send it to CDLLC, attention Product Service, 2 Talcott Rd., West Hartford, CT 06110. It is recommended that you contact Product Service at 1-800-962-COLT before shipping any firearm. (Do not include “Colt” or indicate the contents of the package anywhere on the package)

Before shipping your firearm, here are some points to remember:

 **CAUTION: MAKE SURE THE FIREARM IS UNLOADED AND THE MAGAZINE IS EMPTY BEFORE SHIPPING**

- Include a letter explaining the problem and your requirements in as much detail as possible. Include the model name and serial number of your firearm together with your return address, day time telephone number, and email address, then enclose the letter with the firearm in a well padded package.
- Insure the package and its contents against theft or loss.
- Do not send presentation boxes, accessories, or explosive components.

IMPORTANT: If you make unauthorized adjustments or use unauthorized parts in your firearm, Colt will not assume responsibility for the functioning of the firearm.

NOTE: This firearm is manufactured to perform properly with the original parts as designed. It is your duty to make sure any parts you buy are installed correctly and that neither replacements nor originals are altered or changed. **That is why we strongly recommend that you have your firearm serviced by Colt.** Your firearm is a complex tool with many parts that must relate correctly to other parts. **Assembling a firearm wrong or with modified parts can result in a damaged firearm, danger, and injury or death to you and others through malfunction.** Always have a qualified gunsmith work on your firearm. Any work that you suspect was not performed by a gunsmith should be checked by a competent gunsmith or returned to Colt for inspection.

NOTE: Various federal and state laws and local ordinances govern the transfer and transportation of firearms, so take the advice of a Dealer in your state on how to send or transport your firearm to Colt.

SAFETY DEPENDS ON YOU

NOTES

SAFETY DEPENDS ON YOU

If your instruction manual becomes lost or destroyed, obtain a replacement by writing to Colt Defense LLC, P.O. Box 118, Hartford, Connecticut 06141-0118, USA or call 1-800-241-2485. When requesting a manual, include the information which is on the left side of your firearm together with its serial number or quote the part number as shown on the back of this manual.



COLT, COLT (stylized "C"), and the RAMPANT COLT (design) are the exclusive property of New Colt Holding Corp. and licensed to Colt Defense LLC. Other trademarks used herein are owned by Colt Defense LLC. For permission to reprint for noncommercial instructional purposes, prior approval from Colt Defense LLC is required.

This instruction manual should always accompany this firearm. When you lend, give or sell this firearm, be sure this manual goes with it.

SAFETY DEPENDS ON YOU

FIVE BASIC SAFETY RULES:

- 1. ALWAYS KEEP THE GUN POINTED IN A SAFE DIRECTION.**
- 2. KEEP FIRE CONTROL SELECTOR ON “SAFE” UNTIL READY TO FIRE.**
- 3. UNLOAD WHEN NOT IN USE.**
- 4. ALWAYS ENSURE A GUN IS NOT LOADED BEFORE CLEANING, DISMANTLING OR STORING.**
- 5. PRACTICE HANDLING AN EMPTY GUN BEFORE ATTEMPTING TO FIRE.**



WARNING: IF THERE IS ANYTHING YOU DO NOT UNDERSTAND, GET HELP FROM SOMEONE QUALIFIED IN THE SAFE HANDLING OF FIREARMS. IF NECESSARY, CONTACT COLT DEFENSE LLC AT:

Customer Service
P. O. BOX 118
HARTFORD, CT 06141-0118

OR

Product Service
2 Talcott Rd
West Hartford, CT 06110

Tel: 1-800-241-2485
Fax: 1-860-244-1449

E-Mail: CS@colt.com
Webpage: www.colt.com