

RIFLE, AR-15

CALIBER 5.56 mm (.223)

DEPARTMENT OF THE AIR FORCE

Digitized by:

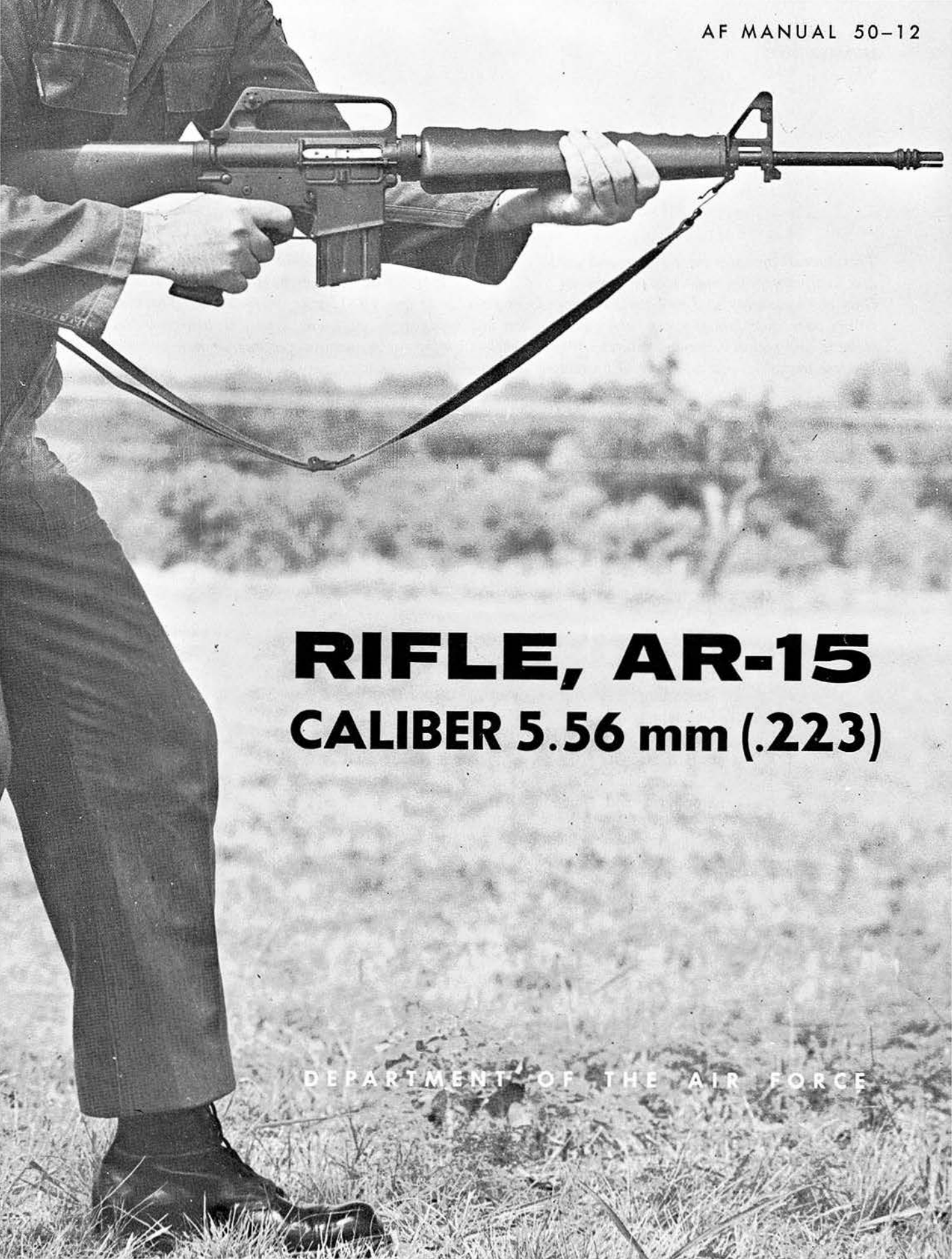

RIFLE, AR-15
CALIBER 5.56 mm (.223)

DEPARTMENT OF THE AIR FORCE

Training

RIFLE, AR-15, CALIBER 5.56 mm, (.223)

This manual provides information and guidance for qualified marksmen, qualified small arms technicians, and instructors who must use or maintain this weapon. It is not intended to be a basic small arms text. Only marksmanship and maintenance procedures peculiar to the AR-15 rifle are included. The manual covers operation, function, care and cleaning, and maintenance in sufficient detail to help standardize training and maintenance procedures. When additional information, new procedures, or new accessories become available, this manual will be revised or changed as necessary.

CONTENTS

Chapter	Page
1 — INTRODUCTION	
Description	1-1
Data	1-3
2 — OPERATION	
Safety	2-1
Loading	2-1
Firing	2-2
Reloading	2-3
Unloading	2-3
Sights and Sight Adjustment	2-3
Battle Sights	2-3
Telescopic Sight	2-5
Stoppages and Immediate Action	2-6
Grenade Firing	2-6
Combat Firing Positions	2-7
3 — FUNCTION	
Cycle of Operation	3-1
Firing	3-1
Unlocking	3-2
Cocking	3-3
Extracting	3-3
Ejecting	3-3
Feeding-Chambering	3-4

OPR: AFPTRTC
DISTRIBUTION: F

This training manual is published by Air Training Command in accordance with AFR 5-5

Chapter	Page
Locking	3-5
Semiautomatic	3-5
Automatic	3-6
4 — FIELD CARE AND CLEANING	
Disassembly (Field Stripping)	4-1
Cleaning Before Firing	4-3
Cleaning After Firing	4-4
Assembly	4-5
Function Check	4-6
5 — MAINTENANCE	
Detailed Disassembly	5-1
Lower Receiver Group	5-1
Upper Receiver Group	5-3
Front Sight	5-3
Rear Sight	5-3
Ejection Port Cover	5-4
Bolt	5-4
Magazine	5-4
Major Inspection	5-5
Barrel and Barrel Extension	5-5
Front Sight and Gas Tube	5-5
Upper and Lower Receiver and Internal Parts	5-5
Bolt and Bolt Carrier	5-6
Replacement and Adjustment of Parts	5-6
Assembly	5-6
Upper Receiver Group	5-6
Bolt and Bolt Carrier	5-6
Checking Headspace	5-6
Lower Receiver Group	5-6
Magazine	5-6
Final Assembly	5-7
Reporting Defective Parts	5-7
Function Check and Test Fire	5-7
Test Fire	5-7
Parts List	5-9
Accessories	5-9
Malfunctions	5-10
Special Tools	5-10
6 — AMMUNITION	
Types	6-1
Ballistic Data	6-1
Packaging	6-2

The drawings in Chapter 3 are furnished through the courtesy of Colt's Patent Fire Arms Manufacturing Co., Inc., Hartford 14, Conn. Reproduction of these drawings in whole, or in part, without the express permission of Colt's, is prohibited.

Suggestions for improvement of this manual are invited. Submit recommendations to Director, Personnel Procurement and Training (AFPTRTC), Headquarters USAF, Washington 25, D. C.

CHAPTER 1

Introduction

The AR-15 rifle, a new weapon developed by private industry, is being procured as a standard rifle for individual issue throughout the Air Force. Its performance, design, construction, and versatility all contribute to simplicity of operation.

DESCRIPTION

*The AR-15 is a caliber 5.56 mm (.223),

*Cartridge was previously identified as 5.64mm (.223).

magazine-fed, gas-operated, air-cooled, shoulder weapon. It can be fired either automatically or semiautomatically simply by moving the safety-selector level. Figure 1-1 shows the left and right sides of the weapon. Figure 1-2 shows the rifle with some of the accessories which add to its versatility. Much of the versatility and performance, however, is gained through several new and unique design and construction features.

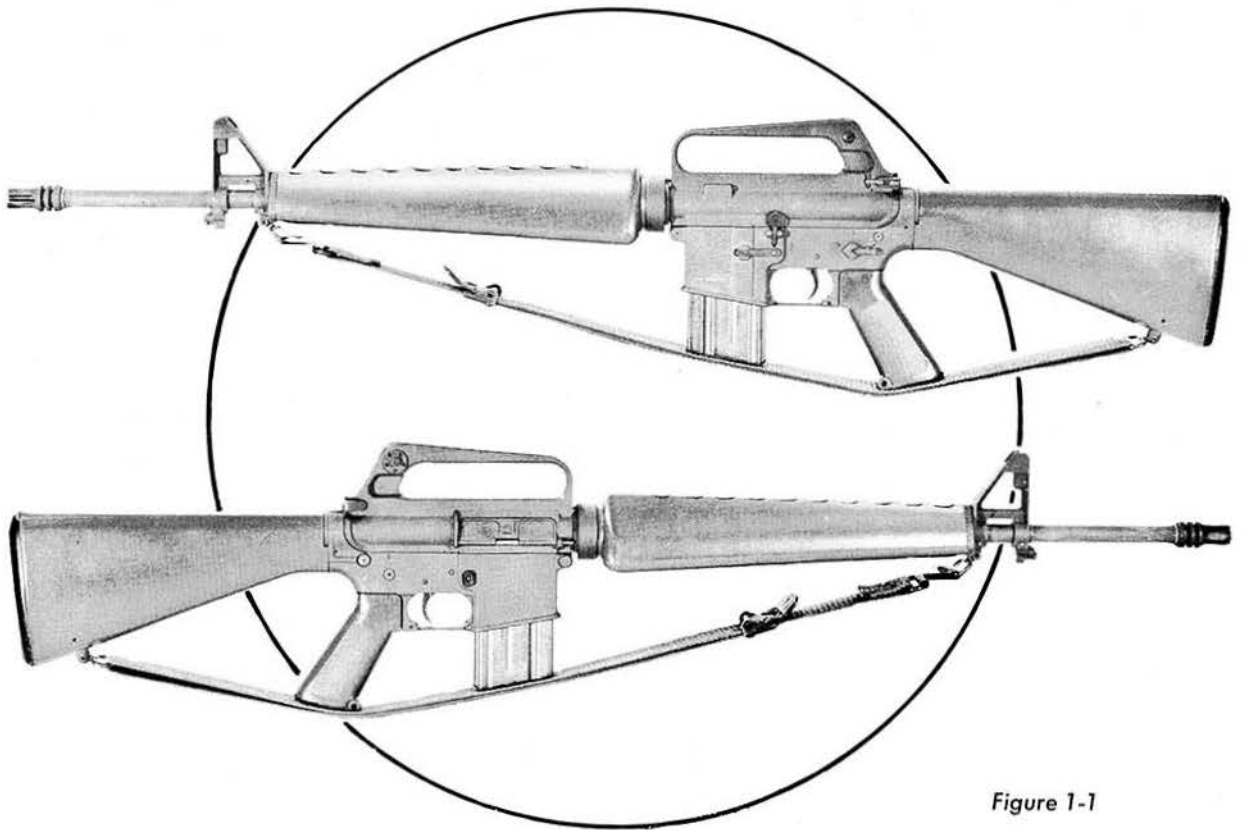

Figure 1-1

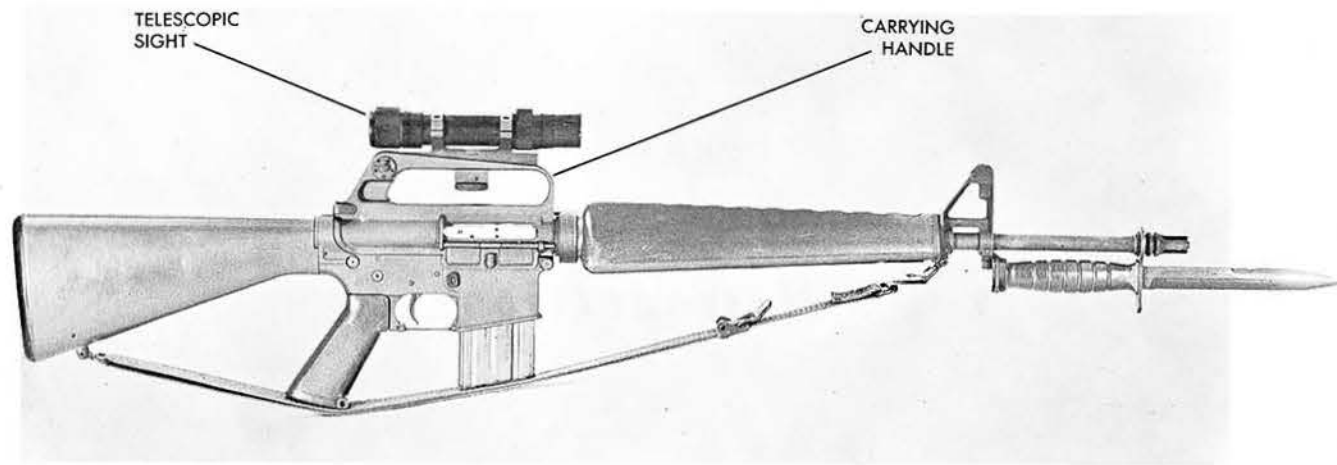

Figure 1-2

Unique Features

- The straight line design from muzzle to stock is shown in figures 1-1 and 1-2. This feature reduces the effect of recoil and vertical dispersion (climb), thus improving accuracy.
- This light weight shoulder weapon can deliver the comparative firepower of a light machine-gun, while the high velocity, flat trajectory 5.56 mm bullet gives extreme accuracy.
- The bolt and bolt carrier together form a piston and cylinder, which are actuated by the gas fed back through the gas tube, from the gas

port near the muzzle. This system eliminates the necessity of the operating rod used in a conventional gas piston and bolt system. The result is the reduction of a maintenance problem and less over-all weight.

- The extensive use of light, corrosion resistant alloys and plastics reduces weight and minimizes cleaning, lubrication, and maintenance requirements.
- The ejection port cover and receiver completely enclose the bolt, giving maximum protec-

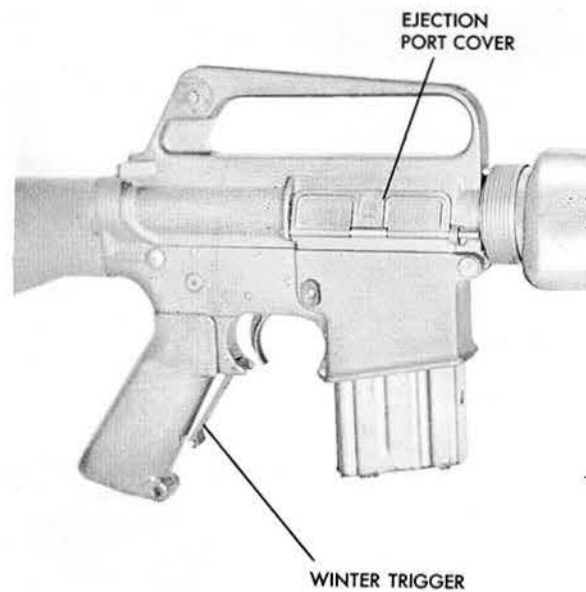

Figure 1-3

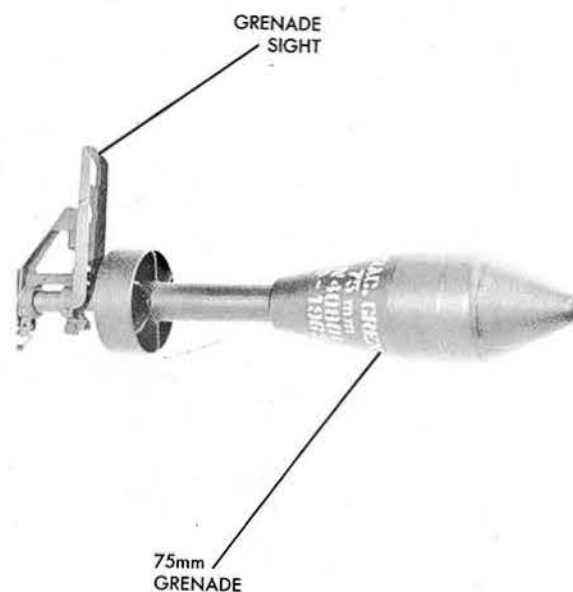

Figure 1-4

tion against sand and dirt which could cause malfunctions and excessive wear.

- The trigger guard is hinged so that it may be folded back against the pistol grip, as shown in figure 1-3, to allow the weapon to be fired in arctic climates without removing gloves or mittens.
- The flash suppressor also serves as a grenade launcher, as shown in figure 1-4. This permits instant conversion from rifle to grenade launcher without the use of tools or special adapters.
- Provision is made in the carrying handle section of the upper receiver for mounting a telescopic sight.
- A bipod may be instantly mounted on the barrel at the front sight, as shown in figure 1-5.

All of these features permit this weapon to function under all climatic conditions.

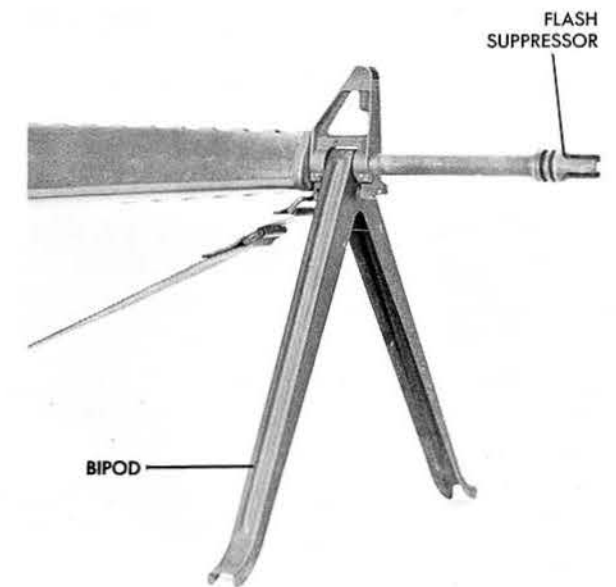

Figure 1-5

DATA

<i>Weight (pounds)</i>	
Rifle without accessories	6.31
Empty magazine	.31
Sling	.31
Telescope	.875
Cleaning equipment	.125
Bipod	.56
Bayonet	.625

<i>Length (inches)</i>	
Rifle with flash suppressor	39
Rifle with bayonet	44.25
Barrel	20
Barrel with flash suppressor	21

<i>Mechanical Features</i>	
Rifling	RH, 6 groove, 1 turn in 12"
Bore Maximum	.220 in.
Groove Maximum	.2245 in.
Sight radius	19.937 in.
Trigger pull	
Maximum	9.0 lbs.
Minimum	5.0 lbs.
Loading devices	20 round magazine
Method of operation	Gas

Type of mechanism	Rotating bolt
Method of feeding	Magazine—20 rds. cap.
Chamber pressure	52,000 psi max average
Cooling	Air
<i>Ammunition</i>	
Caliber	5.56 mm (.223)
Type	Ball and Tracer

<i>Firing Characteristics</i>	
Muzzle velocity (approx.)	3250 ft. per sec.
Muzzle energy	1328 foot lbs.
Cyclic rate of fire	700/800 rds. per min.
Maximum rate of fire	
Semiautomatic	45/65 rds. per min.
Automatic (using 20-round magazines)	150/200 rds. per min.
Sustained rate of fire	12/15 rds. per min.
Maximum effective rate of fire	
Semiautomatic	30/40 rds. per min.
Automatic	50/70 rds. per min.
Maximum range	2833 yds.
Maximum effective range	500 yds.

Operation

Before discussing loading and firing of the AR-15 rifle, you are reminded to observe all safety precautions. You are responsible for your own safety and that of others around you. Start practicing safety the minute you pick up this rifle by assuming that it is *always* loaded until you, personally, have inspected it.

Inspect the rifle by removing the magazine, opening the bolt and locking it open, looking in the receiver and chamber, and setting the safety-selector lever on SAFE. Before loading and firing the weapon, especially for the first time, become thoroughly familiar with the safety-selector lever on the weapon.

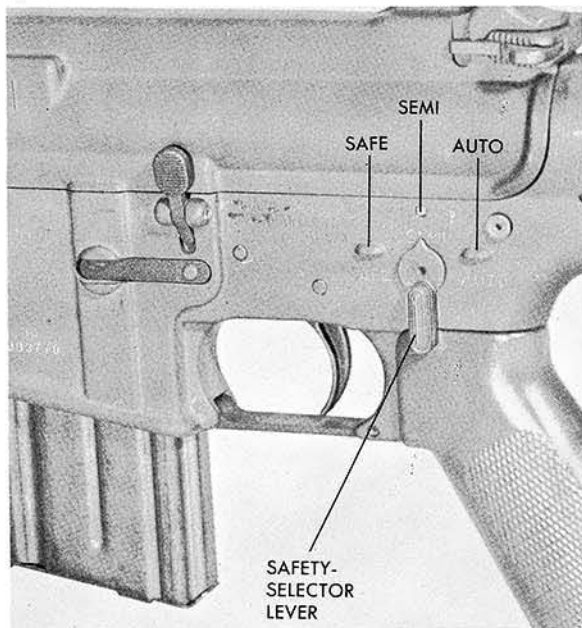

Figure 2-1

SAFETY

The safety-selector lever is located on the left side of the lower receiver, just above the pistol grip. See figure 2-1. It is a small metal disk with a pointer on its outer edge and a raised, knurled lever on the edge directly opposite the pointer. It is operated by the thumb as the right hand grasps the pistol grip in the firing position.

There are three positions in which the safety-selector lever can be set, as indicated by the words "SAFE", "SEMI", and "AUTO" stamped on the receiver. Note that the position in which the safety-selector lever is set is indicated by the POINTER, *not the knurled lever*. Note, also, that the safety-selector lever *cannot* be placed on SAFE unless the weapon is cocked. When on SAFE, the safety-selector lever serves the usual purpose of preventing the weapon from being fired. When moved to either of the other positions, the safety-selector lever acts as a fire selector lever.

When you are familiar with the safety-selector lever, and have checked that it functions properly, set it on SAFE and load the rifle.

LOADING

Loading the Magazine

The magazine has a capacity of twenty rounds and may be loaded with any amount up to that capacity. All types of ammunition may be loaded as shown in figure 2-2. The magazine follower has a raised portion generally resembling the outline of a cartridge. Cartridges are loaded into the magazine so that the tips of the bullets point in the same direction as the raised portion of the follower. Correctly loaded ball ammunition and grenade launching cartridges are shown.

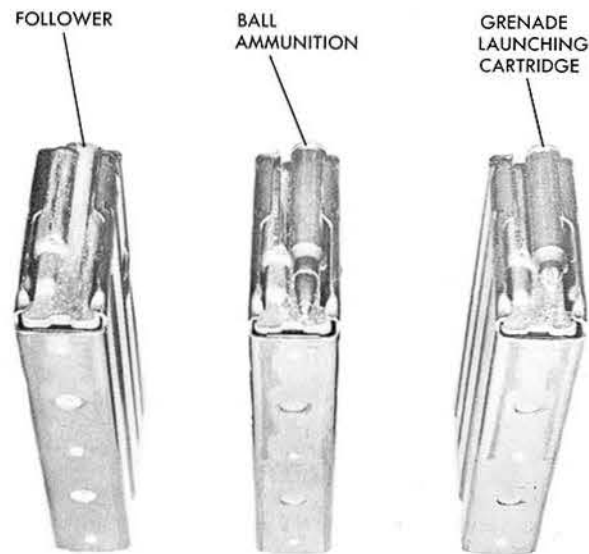

Figure 2-2

Loading the Rifle

The magazine may be inserted with the action open or closed. Hold the stock of the rifle under the right arm with the right hand grasping the pistol grip, and the muzzle pointed in a safe direction. With the left hand, insert a loaded magazine, bullet tips toward the muzzle, into the magazine housing of the lower receiver. Push upward until the magazine catch engages and holds the magazine.

If the action is open, depress the upper portion of the bolt catch, figure 2-3, with the thumb of the left hand, allowing the action to close, chambering

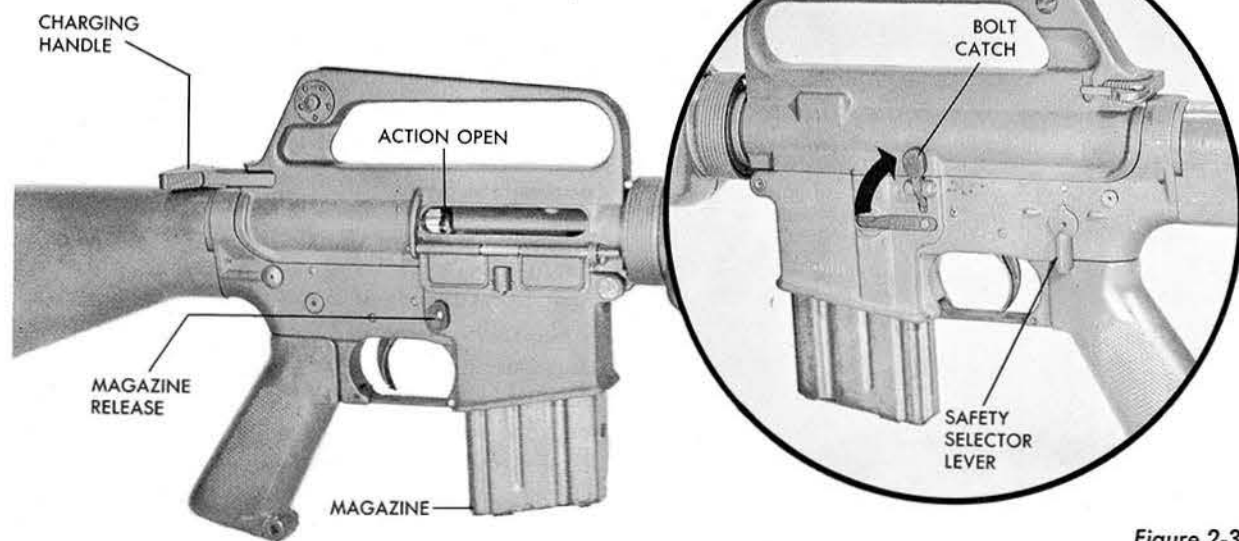

Figure 2-3

a round. If the action is closed when the magazine is inserted, pull the charging handle fully to the rear with the right hand, *and release it*. Do not "ride" the charging handle forward with the right hand. If the charging handle is eased forward from the open position, the bolt may fail to lock and the weapon will not fire.

By following the directions as given will assure that the rifle is correctly loaded and ready to fire.

FIRING

The rifle may be fired semiautomatically or fully automatic by moving the safety-selector lever to the desired position.

SEMI Position

With the safety-selector lever in this position, the rifle will fire one round each time the trigger is pulled.

AUTO Position

With the safety-selector lever in this position, the rifle will continue to fire until the magazine is empty or until the trigger is released. When the rifle is fired on either SEMI or AUTO, the bolt will lock open when the last round from a magazine has been fired.

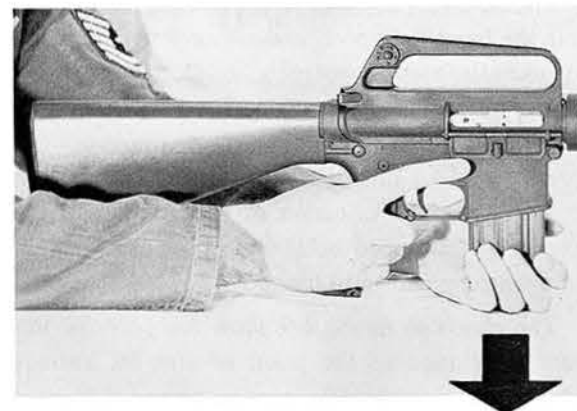

Figure 2-4

RELOADING

Remove the empty magazine by depressing the magazine release button, shown in figure 2-4, with the forefinger of the right hand. Insert a loaded magazine, and close the action as described in the paragraph headed LOADING.

UNLOADING

To unload a cocked, loaded rifle, move the safety-selector lever to SAFE, depress the magazine catch button and remove the loaded magazine. Pull the charging handle to the rear, opening the action, and ejecting the round from the chamber. Lock the action open with the bolt catch as shown in figure 2-5. Look in the receiver and chamber to make sure no round remains.

SIGHTS AND SIGHT ADJUSTMENT

The AR-15 is equipped with an aperture rear sight and a post front sight. These battle sights are adjustable for windage and elevation, and the adjustments are calibrated in *minute of angle* graduations. Each graduation moves the point of impact of the bullet one inch at 100 yards, two inches at 200 yards, etc.

In addition to the battle sights, provisions are made in the carrying handle to mount a telescopic sight. Windage and elevation adjustments on the telescopic sight are internal.

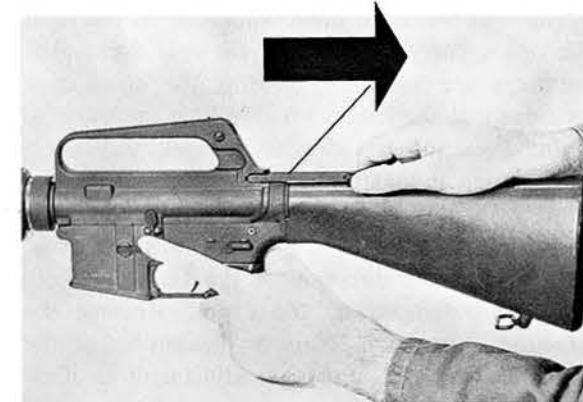

Figure 2-5

Battle Sights

The rear sight is located in the top rear portion of the carrying handle and provides short or long range settings and windage adjustments. There are two apertures on a folding, L-shaped sight. The short range, unmarked aperture is used for short (0-300 yard) ranges. The long range aperture, identified by the letter "L" stamped under the aperture, is used for long (300-500 yard) ranges. Figure 2-6 shows the rear sight and the correct method of changing apertures. These two apertures provide a rapid adjustment in the rear sight for range.

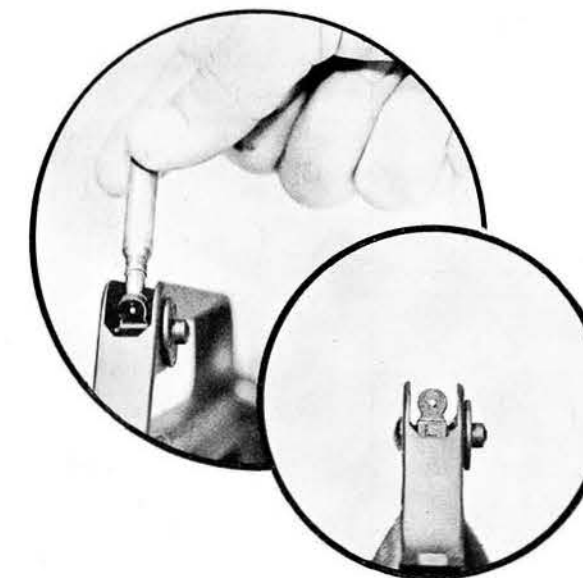

Figure 2-6

The windage adjustment is located on the right side of the carrying handle at the rear sight. Adjustments are made by inserting the point of a cartridge into the lowest small hole in the windage drum. Press the cartridge down firmly to depress the pin detent and at the same time rotate the drum in the desired direction. To move the point of impact of the bullet to the right, turn the drum clockwise, in the direction of the arrow and the letter "R" stamped on the drum. Reverse the direction of rotation to move the impact of the bullet to the left. Windage adjustment is illustrated in figure 2-7.

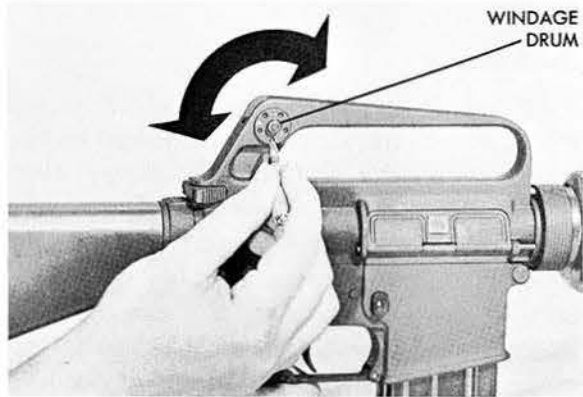

Figure 2-7

The elevation adjustment for zeroing the weapon is in the front sight post, and adjustments are made by using the tip of a cartridge.

Depress the detent at the base of the sight post and turn the post in the desired direction. To move the point of impact up, turn the sight post clockwise, in the direction of the arrow and the word "UP" stamped behind the post. Front sight adjustment is shown in figure 2-8.

The charts in figure 2-9 show the point of impact in relation to the point of aim for various ranges at which the rifle may be zeroed.

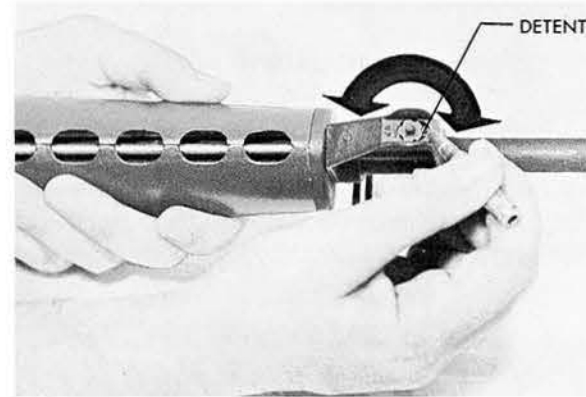

Figure 2-8

Figure 2-9

Rifle zeroed with short range aperture. Ranges fired with short range aperture.					
Zeroed at (yds)	Range in yards				
	100	200	300	400	500
100	0.00	-1.67	-8.73	-23.00	-47.55
200	+ .83	0.00	-6.23	-19.66	-43.38
300	+2.90	+4.13	0.00	-11.37	-33.02
400	+5.75	+9.83	+8.52	0.00	-18.80
500	+9.51	+17.35	+19.80	+15.00	0.00

Rifle zeroed with short range aperture. Ranges fired with long range, "L", aperture.					
Zeroed at (yds)	Range in yards				
	100	200	300	400	500
100	+2.5	+3.33	-1.23	-13.00	-35.0
200	+3.33	+5.00	+1.27	-9.66	-30.88
300	+5.40	+9.13	+7.50	-1.37	-20.52
400	+8.25	+14.83	+16.02	+10.00	-6.30
500	+12.01	+21.35	+27.3	+25.00	+12.5
	+ Inches above line of sight		- Inches below line of sight		

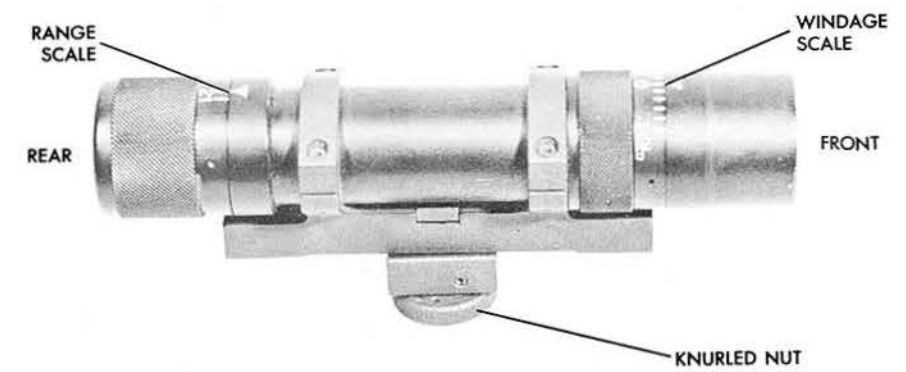

Figure 2-10

Telescopic Sight

The telescopic sight is a 3-power telescope with an inverted post reticle, coated lenses, and internal windage and range adjustments. The sight is shown in figure 2-10.

MOUNTING. To mount the telescope on the rifle, unscrew the knurled nut from the mounting bolt on the telescope. Insert the mounting bolt of the telescope through the hole in the carrying handle of the rifle. Make sure the range adjustment ring of the scope is toward the butt of the rifle. The range adjustment ring has the figures "1" and "2" and is shown in figure 2-8.

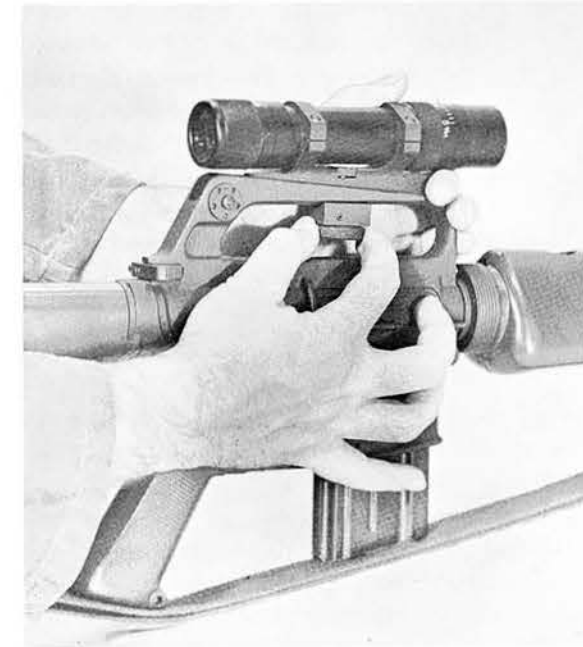

Figure 2-11

Screw the knurled nut on the mounting bolt and tighten securely, making sure that the mounting lug on the bottom of the scope fits securely in the groove in the top of the carrying handle, as shown in figure 2-11. Check the security of mounting by grasping the scope and exerting a firm side-to-side pressure to see that the scope does not loosen. When the telescope is securely mounted, it may then be zeroed to the rifle.

ZEROING. The telescope should be zeroed on a 100 or 200 yard known distance range on a calm day. Before firing, look through the telescope and center the tip of the post reticle in the field of view by turning the windage and range adjustment rings. Figure 2-12 illustrates the inverted post type reticle. Disregard the triangular index marks during the zeroing procedures. Fire the rifle and zero the scope, making sight adjustments with the windage and range adjusting rings. When the scope is zeroed to the rifle, *index* the zero settings.

Figure 2-12



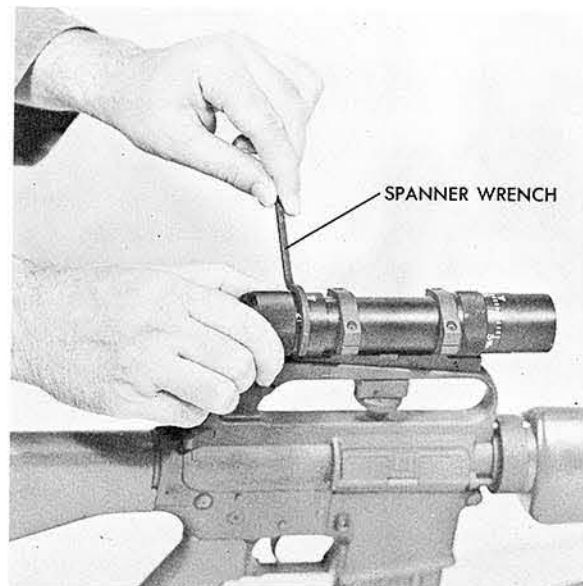

Figure 2-13

INDEXING. To index the zero setting of the telescope, *hold* the knurled portion of the range adjusting ring firmly between the thumb and forefinger to prevent the ring from turning. With the spanner wrench, furnished with the scope, turn the smooth portion of the ring containing the numerals "1" and "2" so that the appropriate numeral is opposite the triangular index mark. If the weapon is zeroed at 100 yards, set the numeral "1" opposite the mark; if at 200 yards, set the numeral "2."

Figure 2-13 shows the indexing procedures on the range scale. Index the windage scale, shown in figure 2-14, in the same manner as that used for the range scale. Set the "0" of the windage scale opposite the index mark. After the scope has been indexed, these scales may be used to adjust for range and windage as necessary for conditions within the limits of the scope. The scope may be removed from, and remounted on, *the same rifle* without further adjustment.

CARE. The telescope is a precision optical instrument and should be treated with the same care afforded any fine pair of binoculars or field glasses. Keep the scope in the case provided when not mounted on the rifle. Keep the lenses covered in inclement weather. Use *only* lens cleaning paper, soft tissue paper, or soft, clean cloth to clean the lenses.

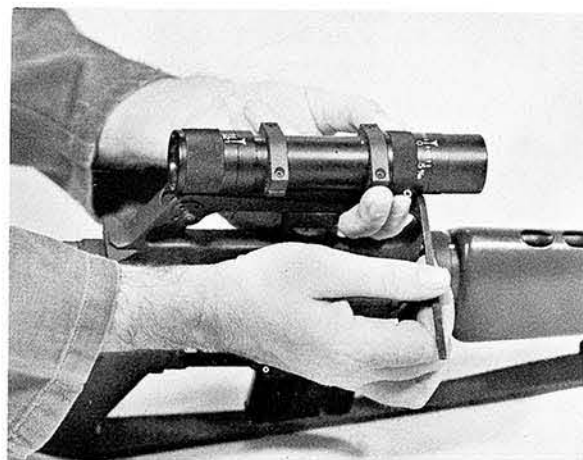

Figure 2-14

STOPPAGES AND IMMEDIATE ACTION

A stoppage is an unintentional interruption in the cycle of operation. When a stoppage occurs, wait 5 seconds before attempting to clear it.

To apply immediate action, after the 5 seconds wait, pull the charging handle fully to the rear and release it. Attempt to fire the weapon. If the weapon still does not fire, push, or strike upward on the bottom of the magazine with the palm of the left hand to make certain that the magazine is securely engaged by the magazine catch.

Visually inspect the receiver to see if a jam has occurred. If so, remove the magazine and clear the jam. If the jam cannot be cleared readily, hold back pressure on the charging handle and, while holding the rifle in a vertical position, strike the butt sharply on the ground to retract the bolt.

If immediate action does not clear the weapon, a malfunction has occurred and must be treated in accordance with instructions contained in Chapter 5.

GRENADE FIRING

The AR-15 rifle can be used as a grenade launcher by using a grenade sight and grenade cartridge.

Each live grenade is issued with a grenade cartridge and expendable aiming sight. Magazines can be charged with grenade cartridges in the same manner as ball ammunition.

To fire a grenade use the following sequence:

- Place the safety in the SAFE position.

- Remove grenade cartridge from base of grenade and insert it in the magazine.
 - Attach the sight to the grenade as prescribed in the instructions furnished with the grenade.
 - Place grenade over muzzle.
 - Remove the grenade safety arming device in accordance with directions furnished with the grenade.
 - Assume the firing position shown in figure 2-15.
 - Move the safety to SEMI position.
 - Pull trigger to launch grenade.
- If grenade is not fired, resafety the arming device.*
- Training grenades are not issued with expendable sights. Training grenade sights are placed*

over the front sight of the rifle as shown in figure 2-16. Use the same sequence of fire as described above.

COMBAT FIRING POSITIONS

The rifle may be fired semiautomatically or fully automatic from any position which provides weapon control and accuracy. When firing for annual qualification requirements in accordance with AFR 50-8, *Small Arms Marksmanship Training*, shooters should use the positions described in AFM 50-4, *Carbine, Calibre .30*. These positions can be used for semiautomatic fire with very minor adjustments to accommodate the pistol grip of the AR-15.

Figure 2-15

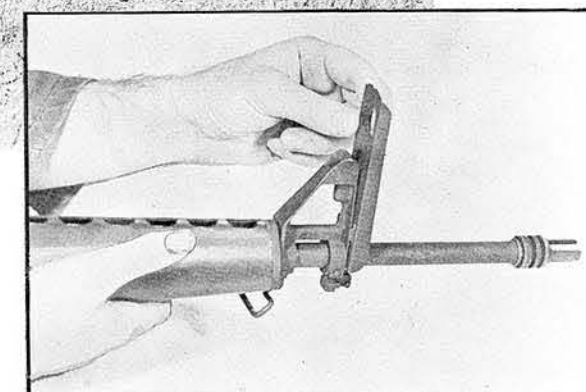
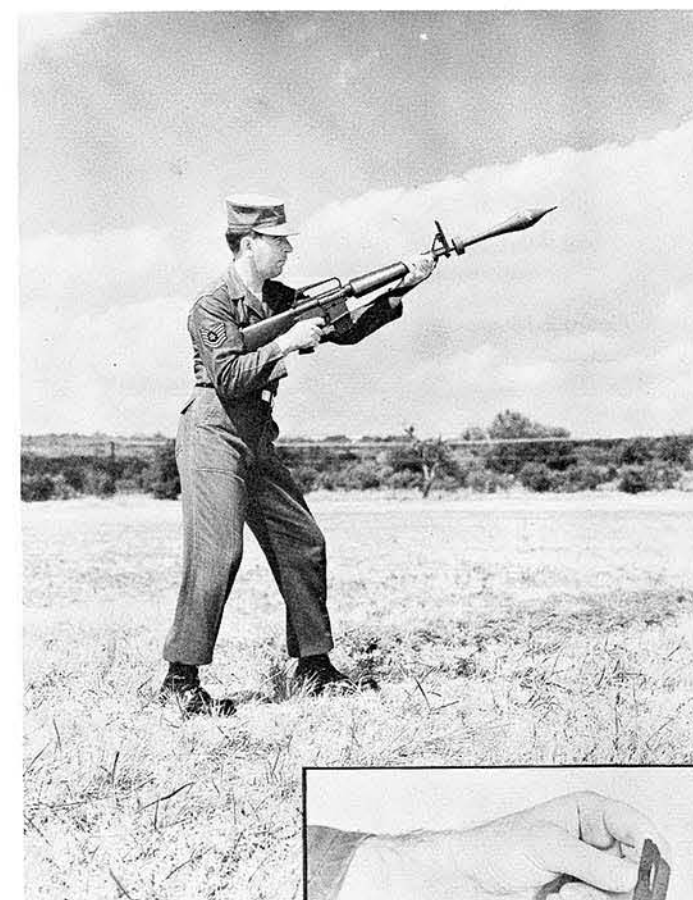

Figure 2-16

Figure 2-17



All shooters should be required to become familiar with the automatic fire characteristics of the weapon. For this purpose, either of the positions shown in figures 2-17 and 2-18 are suitable. Each has certain advantages. Figure 2-17 offers freedom of body movement, and facility to move quickly from one target to another. Figure 2-18 offers excellent weapon stability, and good control over vertical dispersion (climb).

The bipod may be used in combat situations to aid in stabilizing the weapon in semiautomatic or fully automatic fire. It may be used in any position where a suitable rest is available. Figure 2-19 illustrates the use of the bipod in the prone position.

Figure 2-18



Figure 2-19

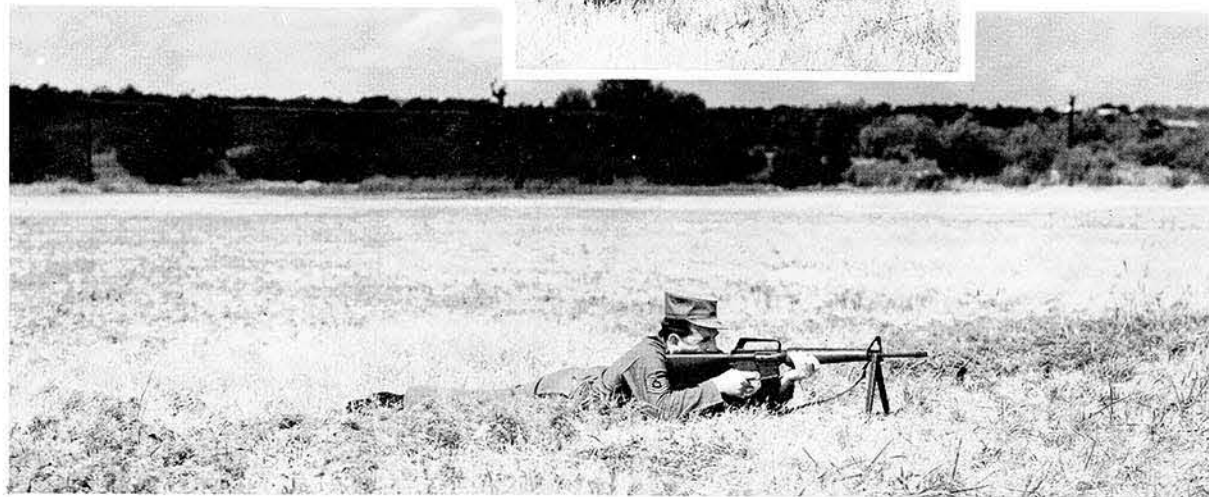

CHAPTER 3

Function

Each time a round is fired, many parts inside the AR-15 rifle function in a given order. This order, or sequence, is known as the *cycle of operation*. A knowledge of what happens inside the rifle will help you understand the cause of, and remedy for, various stoppages or malfunctions.

steps: firing, unlocking, cocking, extracting, ejecting, feeding and chambering, and locking. Although described separately here, the functions of the parts occur simultaneously. With a full magazine in the rifle, and a cartridge in the chamber, the following cycle of operation takes place:

CYCLE OF OPERATION

The cycle of operation is divided into seven

Firing

Figure 3-1 shows the rifle ready to fire. The hammer notch and trigger sear are engaged. When

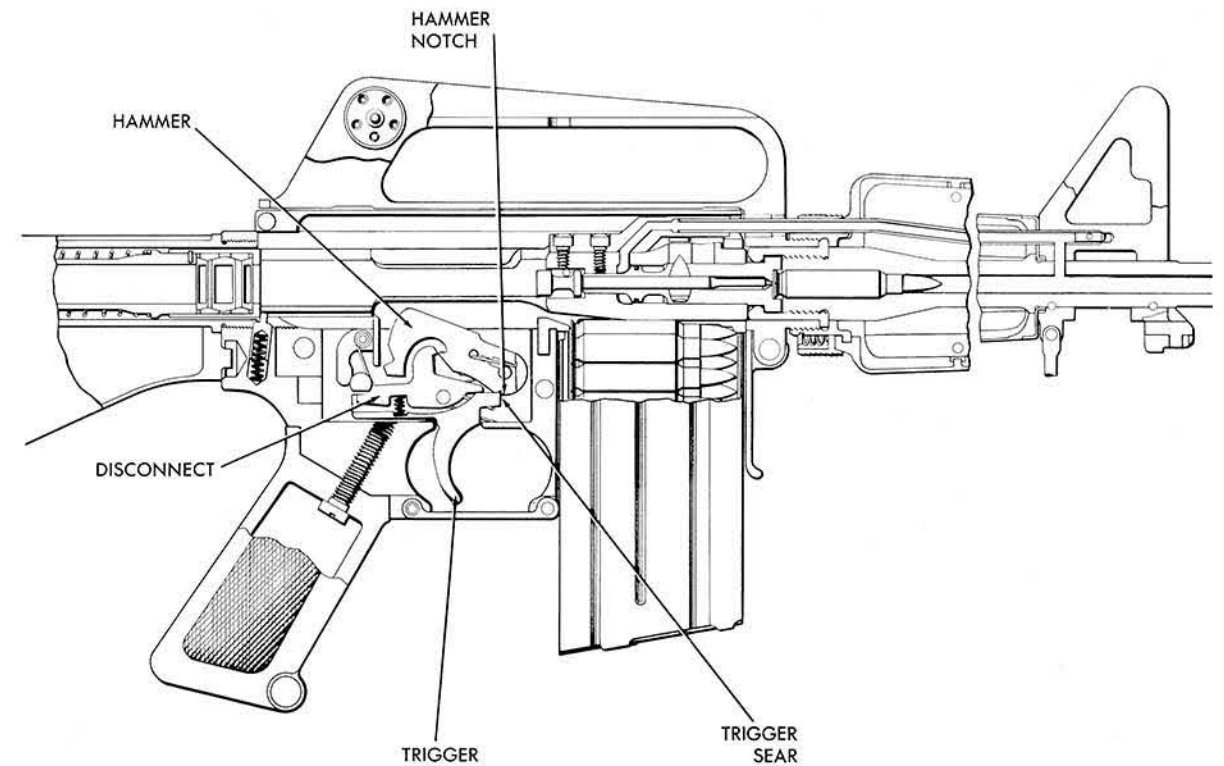

Figure 3-1

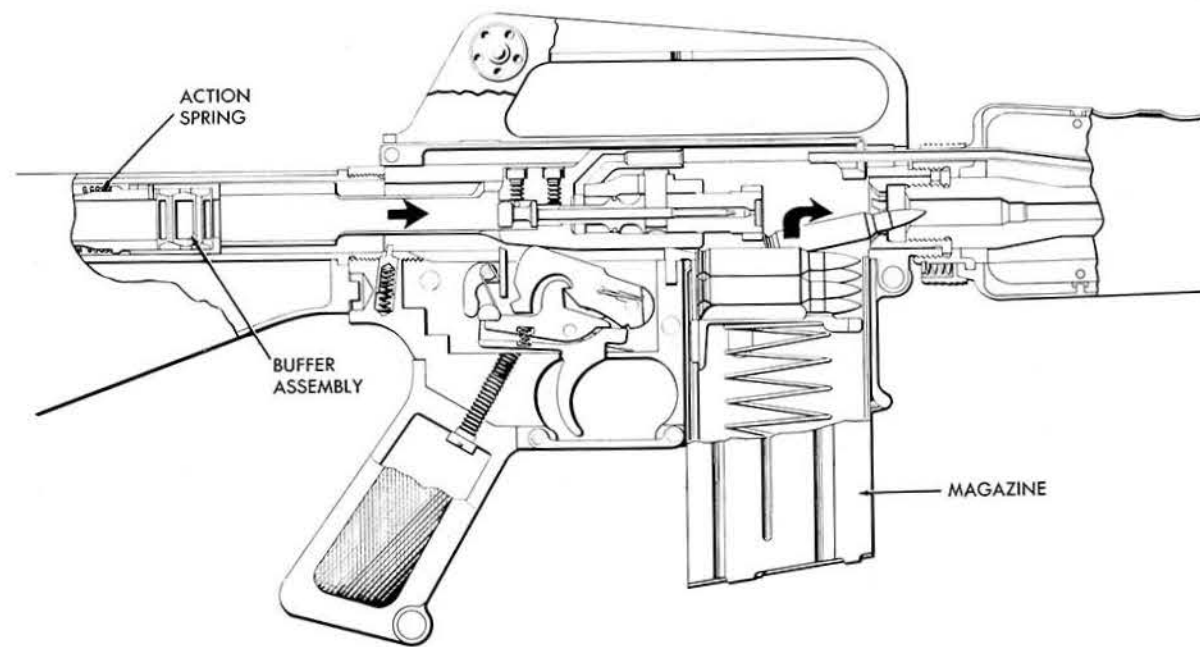

Figure 3-6

Feeding-Chambering

The rearward motion of the bolt carrier is arrested by the buffer assembly and action spring guide. The compressed action spring then forces

the bolt carrier toward the chamber. On its forward motion, the face of the bolt picks up a cartridge from the magazine (feeding) shown in figure 3-6, and thrusts it into the chamber (chambering) as shown in figure 3-7.

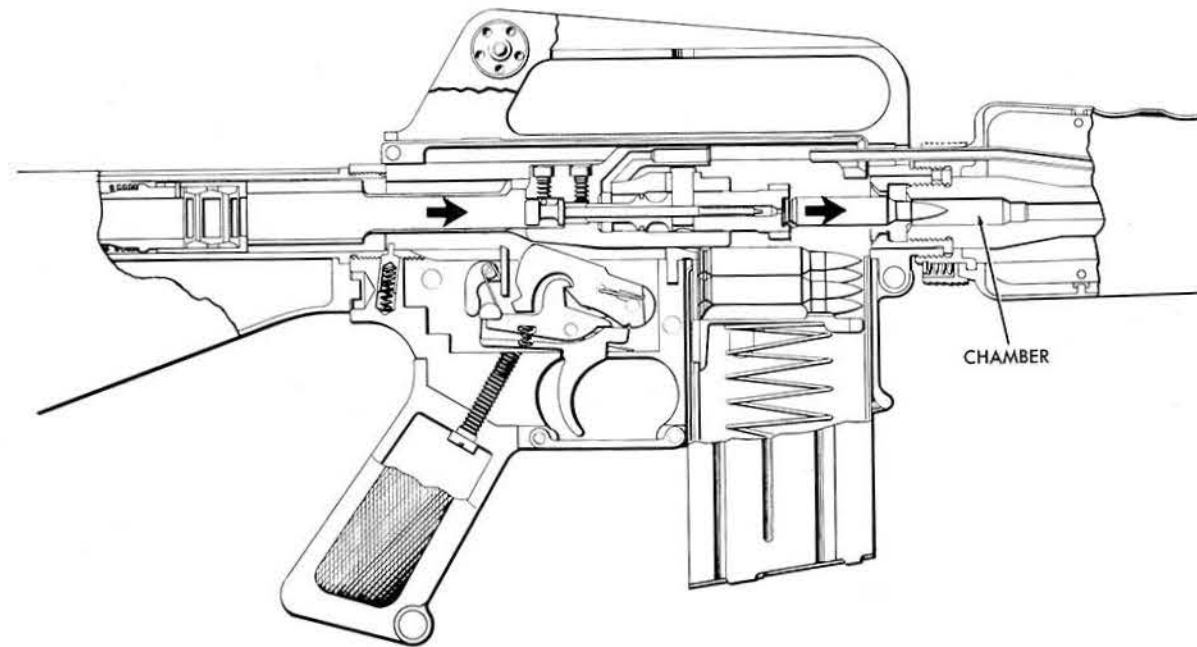

Figure 3-7

Locking

As the bolt lugs enter the barrel extension, the ejector is depressed against the left side of the head. The extractor snaps into the extracting groove of the cartridge case. As the bolt carrier enters the final one-half inch of its closing stroke, the bolt cam pin moves out of the receiver guide. The bolt carrier cam track rotates the bolt and locks it into the barrel extension. This action is the reverse of that shown in figure 3-3.

This completes one cycle of operation. This cycle is the same for semiautomatic or fully automatic fire. Only the function of two key parts, the *automatic sear* and the *disconnect*, are changed by the shooter when he selects the SEMI or AUTO positions.

The *disconnect* prevents the rifle from firing fully automatic when the safety-selector is in the SEMI position. When the trigger is pulled, the disconnect is rotated with the trigger by the action of the disconnect spring. During the cocking step, the hook of the disconnect engages the upper inside notch of the hammer as shown in figure 3-8. This holds the hammer back and prevents a second shot.

When the trigger is released, the trigger spring causes the trigger to return to the normal position carrying the disconnect backward with it. The hammer is then released from the hook on the disconnect. However, before the disconnect hook actually releases the hammer, the trigger sear has moved in front of the hammer notch and the hammer drops from the disconnect to the trigger sear. The weapon is then ready for a second shot.

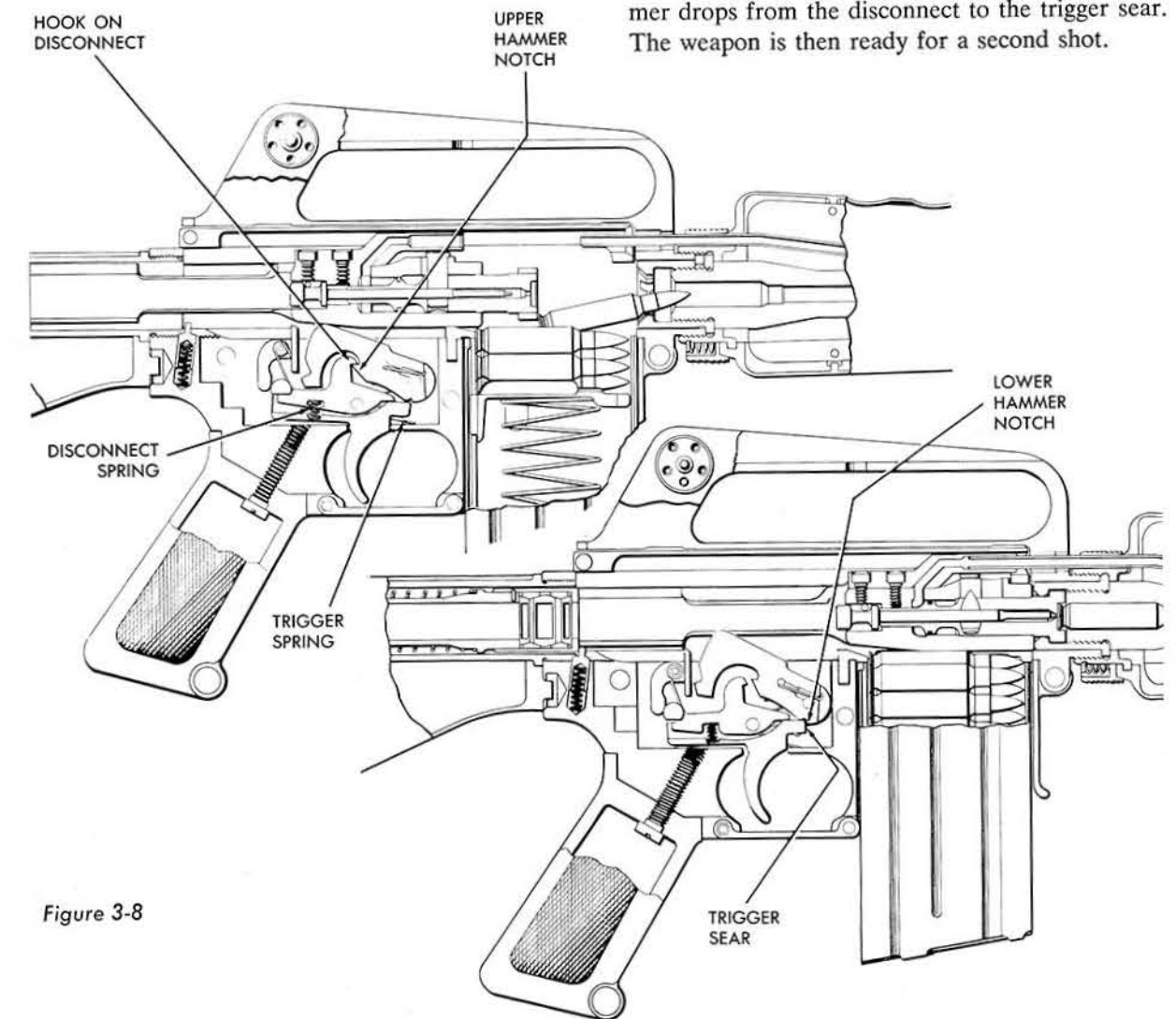

Figure 3-8

AUTOMATIC

When the rifle is fired with the safety-selector in the AUTO position, the hammer is moved into the cocked position by the bolt carrier. The automatic sear engages the top outside notch in the hammer as illustrated in figure 3-9. The sear holds the hammer in a cocked position until the

bolt carrier, during its moment of locking, strikes the upper edge of the automatic sear.

The automatic sear is rotated on its pivot by the action of the bolt carrier, and releases the hammer, allowing it to fall and fire the next round. The cycle repeats, and firing continues until the trigger is released or the magazine is empty.

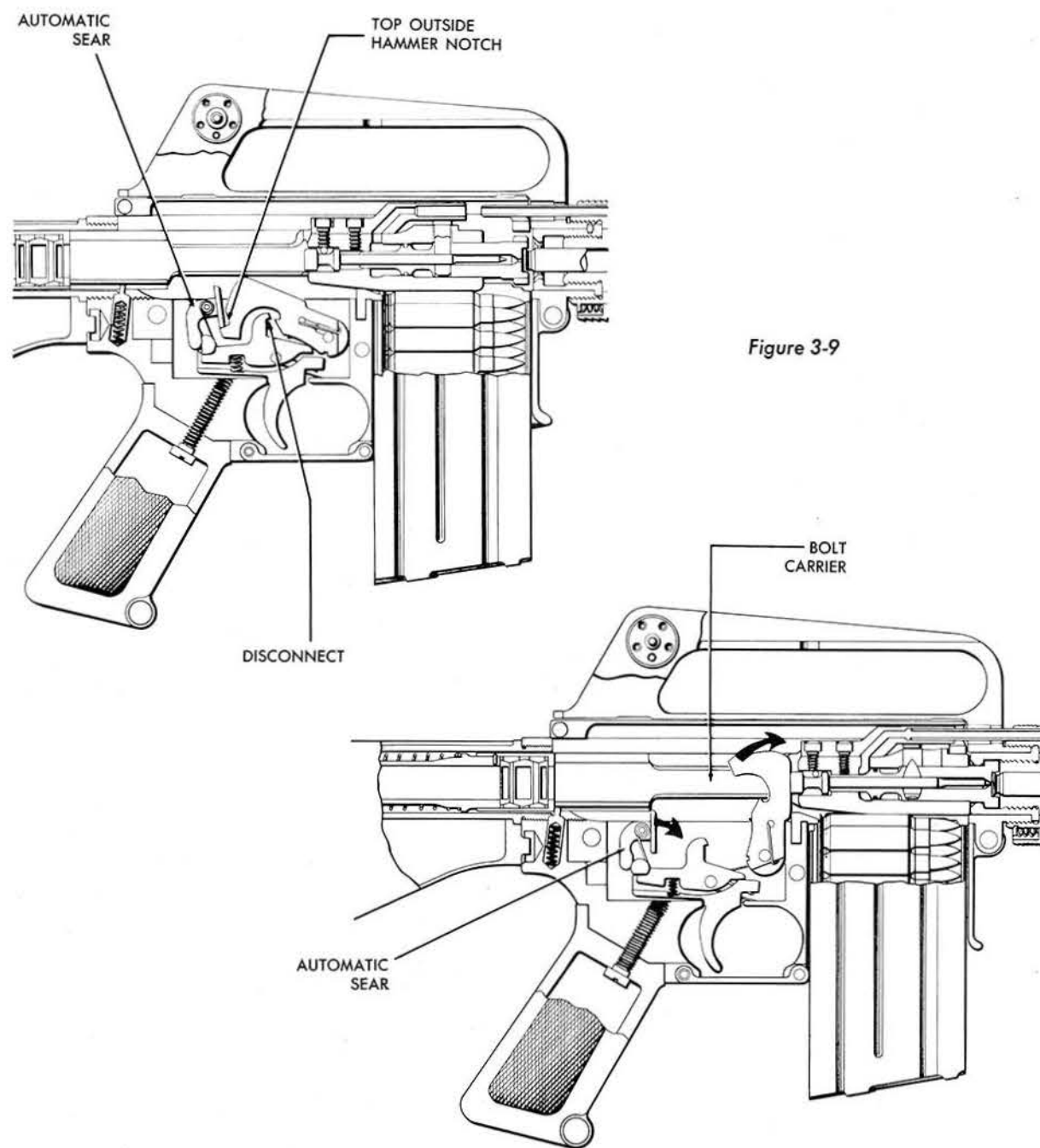

Figure 3-9

CHAPTER 4

FIELD CARE AND CLEANING

The AR-15 rifle should be cleaned after each day's firing. In addition, proper field care requires that you clear stoppages, check the rifle for proper function, and clean and maintain it under field conditions. It will be necessary, therefore, for you to know how to *field strip* (disassemble) it.

DISASSEMBLY

The only tool necessary to field strip the AR-15 rifle is a cartridge. This is highly desirable under combat conditions since the user is not required to carry special tools. Throughout this manual reference is made to the use of the point of a cartridge in disassembling the weapon. This reference in

no way authorizes the use of live, or dummy, ammunition for this purpose in training situations where local directives prohibit such practice.

To field strip the AR-15 rifle, as shown in figure 4-1, first remove the magazine and visually inspect the chamber and receiver to make sure no round of ammunition remains. Remove the bolt carrier group from the upper receiver, then disassemble the bolt from the bolt carrier. Details of these procedures follow.

Removing the Magazine

Grasp the rifle by the pistol grip with the right hand. Keep the muzzle pointed away from you

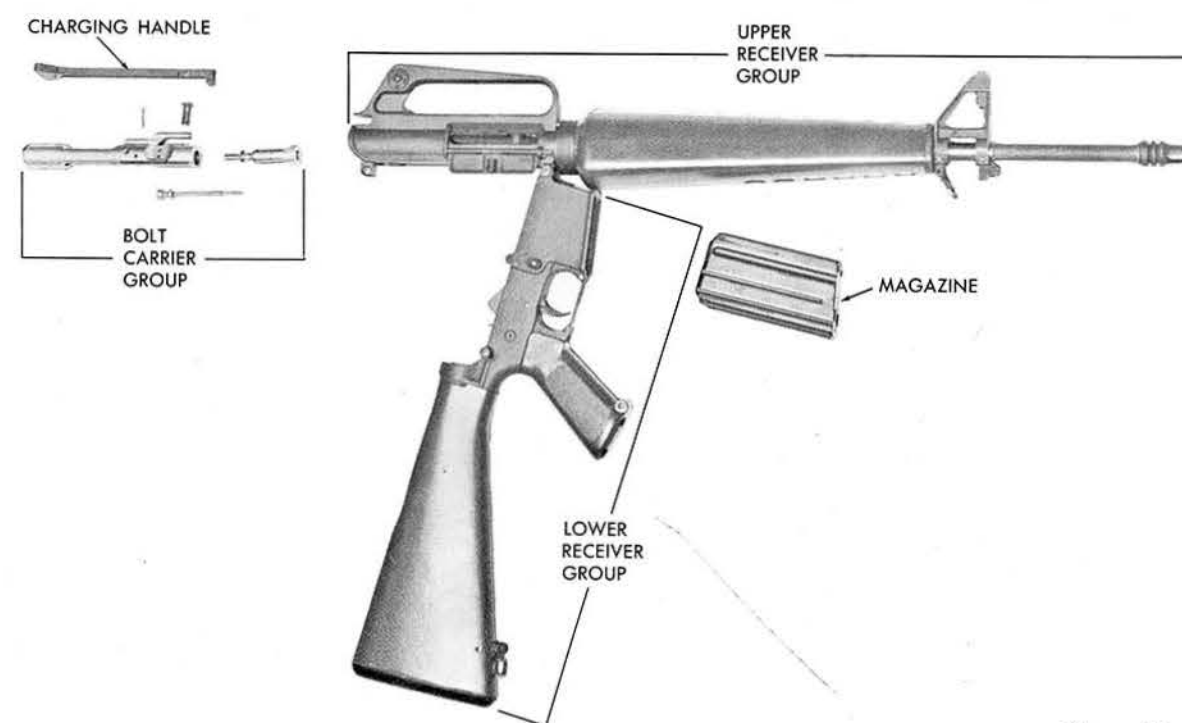

Figure 4-1

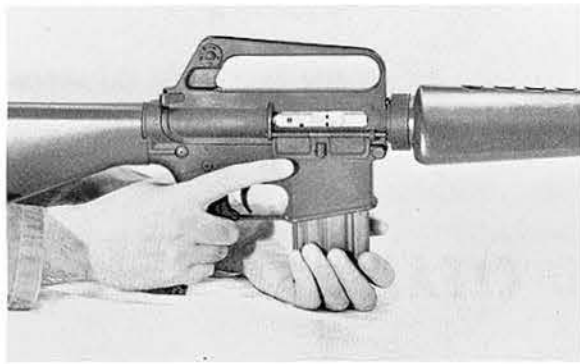

Figure 4-2

and in a safe direction. Hold the left hand under the magazine. Depress the magazine release with the forefinger of the right hand, as shown in figure 4-2, and remove the magazine from the lower receiver. If the magazine fails to release, slight downward pressure with the left hand while depressing the magazine release should free it.

Inspecting for Safe Condition

Pull the charging handle to the rear until the action is fully open. Lock the action open by depressing the lower portion of the bolt catch, as shown in figure 4-3. Return the charging handle to the fully forward, locked position.

Move the safety-selector lever to the SAFE position.

Look in the receiver and chamber to make sure no round of ammunition remains.

Depress the upper portion of the bolt catch, allowing the bolt to go forward, closing the action.



Figure 4-3

Removing the Bolt Carrier Group

With bolt closed and safety-selector lever on SAFE, press out the takedown pin shown in the inset of figure 4-4. With the point of a cartridge, press out *toward* the right side (ejection port side) of the weapon as far as the cartridge will go; then, holding the rifle with the left hand under the handguard, pull out the pin with the right hand until the pin clears the lug of the upper receiver. Use care when allowing the lower receiver to pivot downward. The rifle should now appear as shown in figure 4-4.

Hold the opened weapon in the left hand under the handguard with the rear of the upper receiver slightly elevated. Pull the charging handle to the rear until the bolt carrier protrudes from the rear of the receiver about two or three inches, as shown

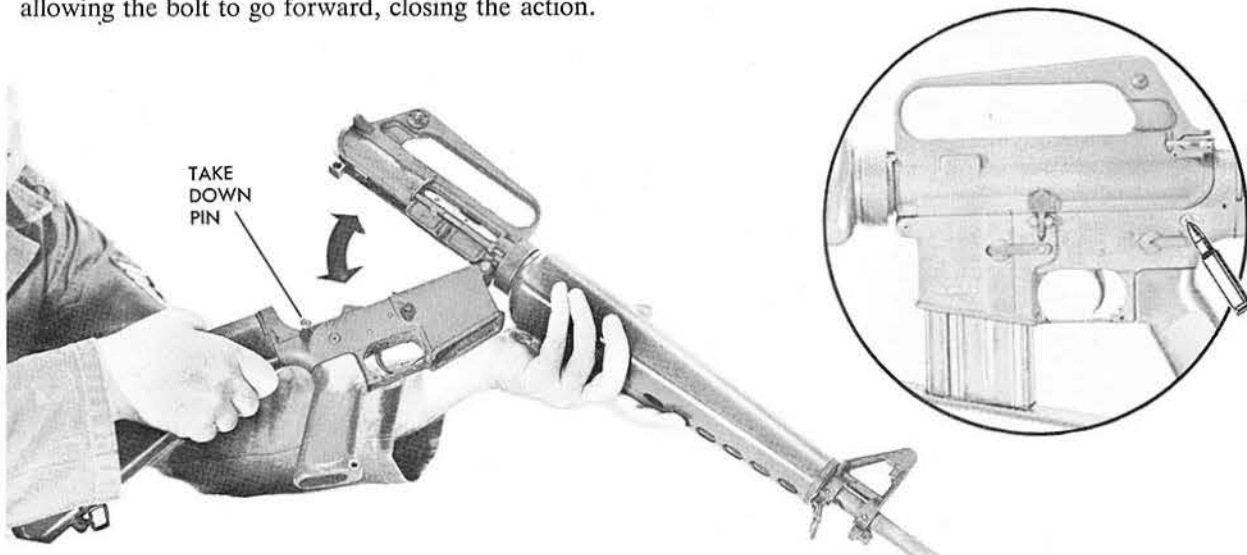

Figure 4-4

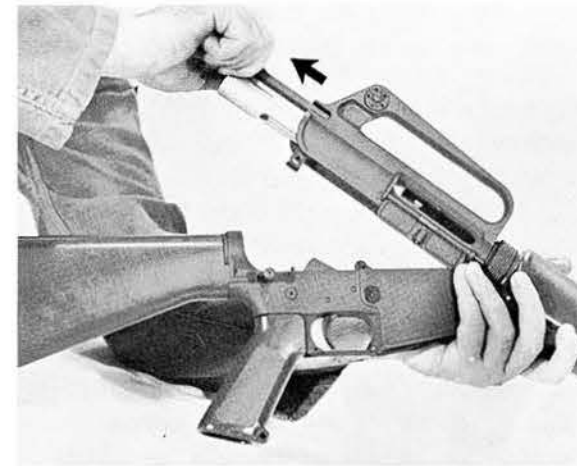

Figure 4-5

in figure 4-5. Grasp the bolt carrier group and pull to the rear, rotating the rear portion downward to clear the bolt carrier key from the groove in the charging handle. This is illustrated in figure 4-6.

Remove the charging handle by pulling it to the rear as far as it will go and allowing it to drop straight downward, then out of the receiver to the rear.

Disassembling the Bolt Carrier Group

Hold the bolt carrier group with the bolt facing away from you, and press out the firing pin retaining pin with the point of a cartridge, as shown in figure 4-7. The firing pin retaining pin is located immediately under the rear bolt carrier key cap screw and should be pressed out *from right to left*. Turn the bolt carrier to the vertical position, and shake the firing pin out the rear of the bolt carrier.

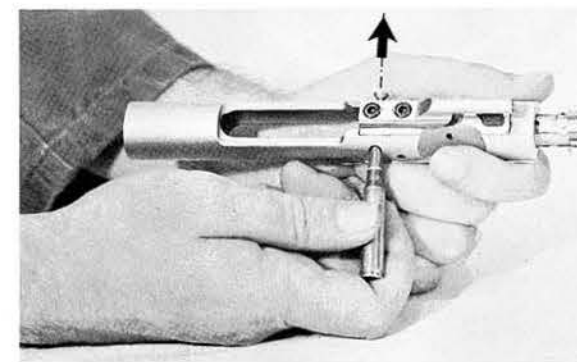

Figure 4-7

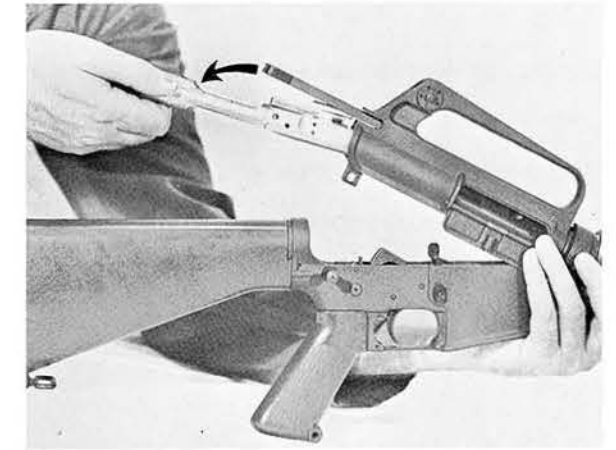

Figure 4-6

Press the bolt all the way into the bolt carrier, making sure that the bolt cam pin is at the extreme rear of the cam slot. Turn the bolt cam pin approximately 1/4 turn in either direction so that a flat edge of the cam pin is aligned with the bolt carrier key, as in figure 4-8, and lift out the bolt cam pin. Pull the bolt out of the bolt carrier.

CAUTION

Do not remove or adjust bolt carrier key cap screws since they control headspace adjustment.

The rifle is now field stripped, ready for cleaning.

CLEANING BEFORE FIRING

All of the necessary cleaning materials are shown in figure 4-9 and consist of a cleaning rod, patches, oil, bore cleaner, and a suitable brush. Satisfactory caliber .22 patches can be obtained by cutting caliber .30 patches into quarters. Cleaning before firing will only be necessary after prolonged storage or under adverse climatic conditions.

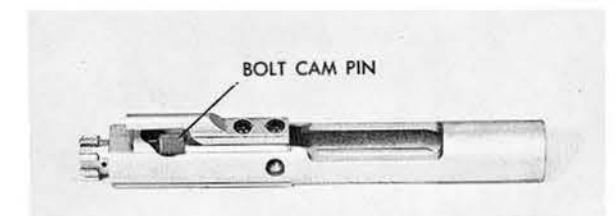

Figure 4-8



Figure 4-9

Cleaning the Bore

Visually inspect the bore *and chamber* for condition and obstructions. If necessary, clean by pushing clean, dry patches through the bore from the chamber to muzzle. Lightly oil all surfaces if the weapon is not to be fired immediately.

Cleaning the Bolt Carrier Group

Wipe any oil or dirt from the external surfaces of the bolt and bolt carrier with clean, dry patches or rag. Clean carbon and dirt from inner surfaces of the bolt carrier which form the gas cylinder. Clean carbon and dirt from cylinder surfaces of the bolt. Check bolt rings for cleanliness and freedom. *Lightly* oil all surfaces for lubrication and to prevent corrosion.

CLEANING AFTER FIRING

Following firing completion, the rifle should be cleaned by using these detailed procedures.

Cleaning the Bore and Barrel Extension

Attach the wire brush furnished with the cleaning rod, dip it in bore cleaner, and brush the bore

thoroughly. Brush the bore *from chamber to muzzle* using straight-through strokes. Do not use a scrubbing action. Push the brush through the bore until it extends beyond the flash suppressor. Continue until the bore is well covered with cleaner. Remove the brush from the cleaning rod, and dry the bore by pushing through clean, dry patches. Continue until patches come out clean and dry.

While holding the weapon with the barrel elevated well above the receiver, clean the locking lugs in the barrel extension, just to the rear of the chamber. Brush the lugs with a suitable brush soaked in bore cleaner, as shown in figure 4-10.

After cleaning, swab the bore with a lightly oiled patch to prevent corrosion and pitting. Lightly oil the locking lugs in the barrel extension.

Cleaning the Bolt Carrier Group

Wipe all dirt from external surfaces of the bolt carrier. Clean all carbon from inner surfaces of the cylinder area.

Scrub all carbon deposits and dirt from the locking lugs and cylinder surfaces of the bolt with a suitable brush dipped in bore cleaner. Brush the face of the bolt, paying particular attention to the area around and under the face of the extractor.

Wipe all surfaces dry with clean, dry patches.

After drying, wipe all surfaces with a *lightly* oiled patch to prevent corrosion.

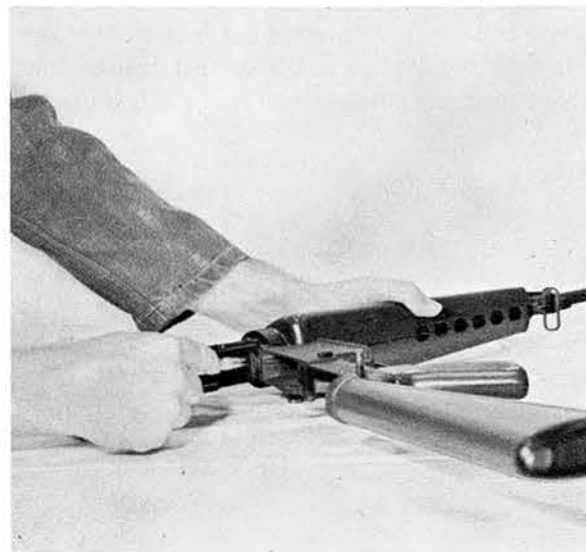

Figure 4-10

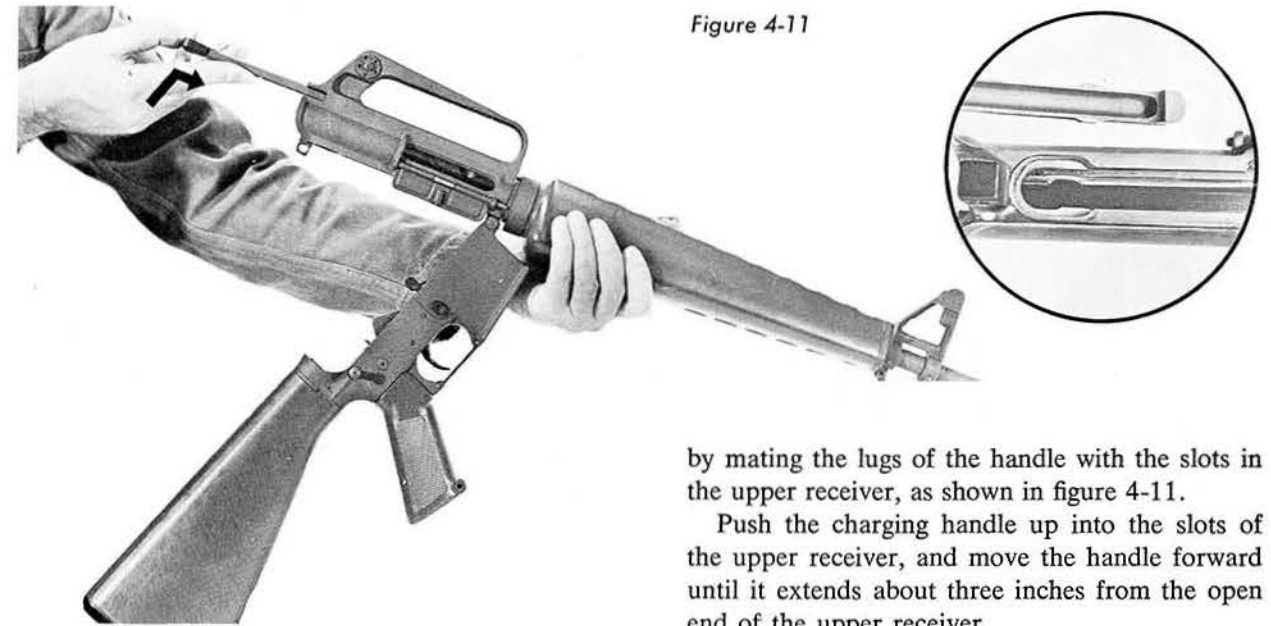

Figure 4-11

Cleaning the Upper and Lower Receiver Group

Carefully wipe all dirt from the internal surfaces of the upper receiver, paying particular attention to the keyway groove in the top of the upper receiver.

Wipe any particles of dirt from the trigger mechanism with a clean patch or brush.

Place a drop of oil on each of the pins for lubrication.

ASSEMBLY

The weapon is again made operative by reassembling and replacing the bolt carrier group, replacing the charging handle, and by locking the upper and lower receiver groups together.

Bolt Carrier Group Reassembly

Reassemble the bolt carrier group by reversing the procedures outlined in the paragraph on disassembly. There is a milled ridge at one end of the bolt cam pin hole in the bolt which permits the cam pin to be inserted into the bolt in only *one direction*. Therefore, it will be necessary to turn the bolt in the bolt carrier until the proper cam pin hole aligns with the bolt carrier cam slot before inserting the bolt cam pin.

Replacing the Bolt Carrier Group

Insert the charging handle in the upper receiver

by mating the lugs of the handle with the slots in the upper receiver, as shown in figure 4-11.

Push the charging handle up into the slots of the upper receiver, and move the handle forward until it extends about three inches from the open end of the upper receiver.

With the bolt carrier group in the left hand and the bolt locking lugs pointing to the right, grasp the locking lugs with the right hand and pull until the bolt cam pin is in its full forward position, as shown in figure 4-12.

While holding the rear of the receiver elevated above the barrel, start the bolt locking lugs into the receiver with the rear of the bolt carrier held at a downward angle, as shown in the inset of figure 4-13. Rotate the rear of the bolt carrier upward while moving it forward into the receiver, at the same time guiding the bolt carrier key into the slot of the charging handle as in figure 4-13.

Push the bolt carrier group toward the muzzle until it locks into the barrel extension.

Locking Upper and Lower Receiver Groups

Cock the hammer if it is not cocked. Make sure the safety-selector lever is on **SAFE**. Close the weapon and press in takedown pin.

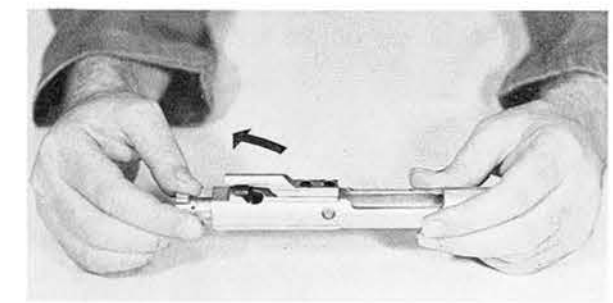

Figure 4-12

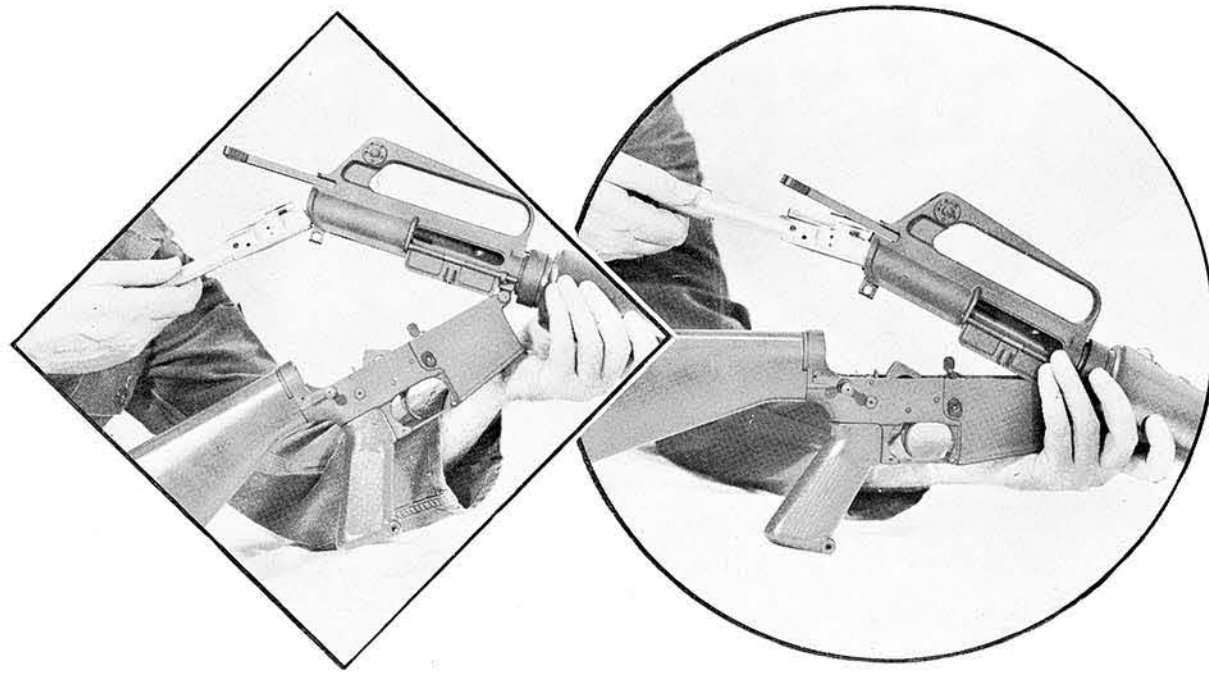

Figure 4-13

FUNCTION CHECK

A complete function check of the weapon consists of checking its operation while the safety-selector lever is in the SAFE, SEMI, and AUTO positions. The following sequence is used for a rapid, complete check. Any portion of the check may be used alone to determine the operational condition of any specific fire selection.

SAFETY Position

Clear the rifle, leaving it cocked with the bolt closed. Place the pointer of the flat surface of the safety-selector lever toward the SAFE position. Pull the trigger with a firm, heavy pull. The hammer should *not* fall.

SEMI Position

With the hammer still cocked from the safety

check, move the safety-selector lever to the SEMI position and pull the trigger. You should hear the hammer strike the firing pin. While holding the trigger down, recock the rifle with the charging handle. Now, release the trigger. An audible metallic click should be heard indicating that the disconnect operates correctly. The hammer should *not* fall.

AUTO Position

Turn the safety-selector lever to the AUTO position with the weapon still cocked. Pull the trigger and the hammer should fall. While holding the trigger down, pull the charging handle fully to the rear and let the bolt snap forward. The hammer should have been released automatically. Release the trigger and pull it again. The hammer should *not* fall.

MAINTENANCE

The detailed disassembly and major inspection of the AR-15 rifle will normally be accomplished by field maintenance activities. The following disassembly and inspection procedures will apply.

DETAILED ASSEMBLY

Field strip the weapon as described in Chapter 4. With a punch or the point of a cartridge, remove the receiver pivot pin located at the extreme front of the lower receiver. Press this pin out toward the right side (the ejection port side). The

weapon is now divided into three main groups, as shown in figure 5-1.

Lower Receiver Group Disassembly

Press out the hammer pin with a punch or the point of a cartridge, as shown in figure 5-2. Lift out the hammer and hammer spring. With a punch or cartridge point, start the automatic sear pin toward the left side of the weapon (the safety lever side). Press the pin completely out of the lower receiver with the tail of the hammer spring. Lift out the automatic sear and spring.

Start the trigger pin out of the receiver in either

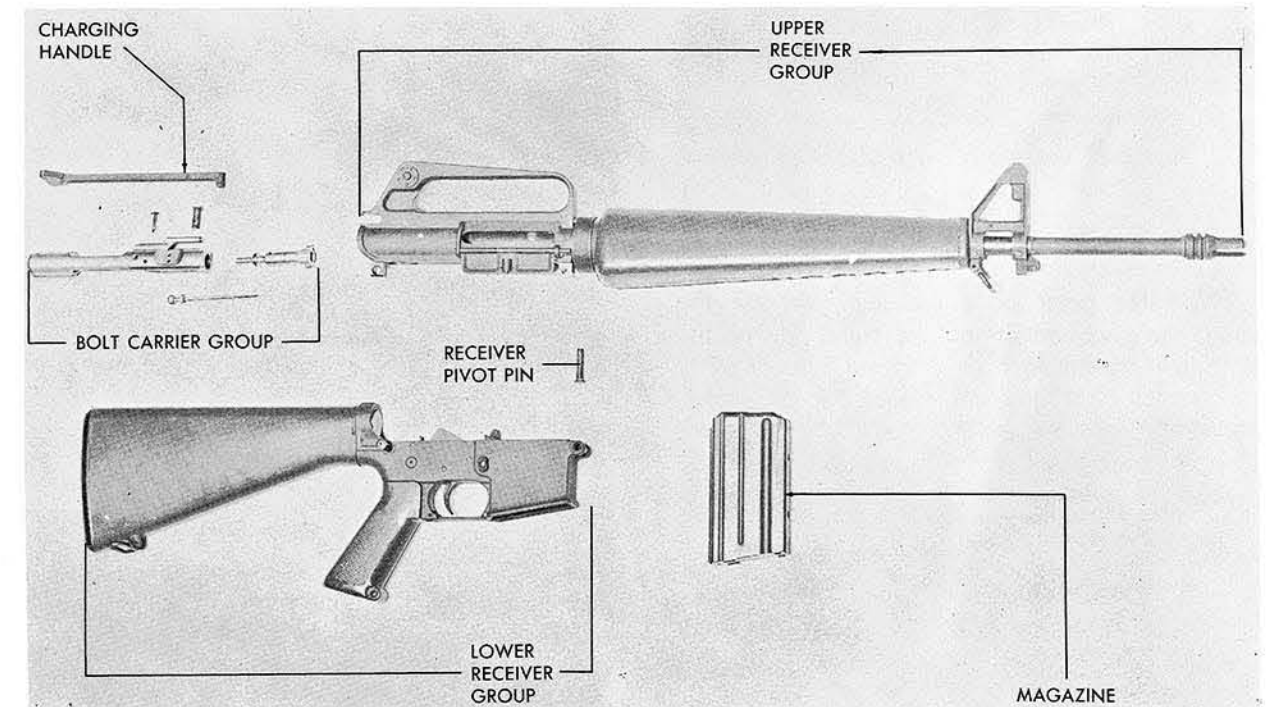

Figure 5-1

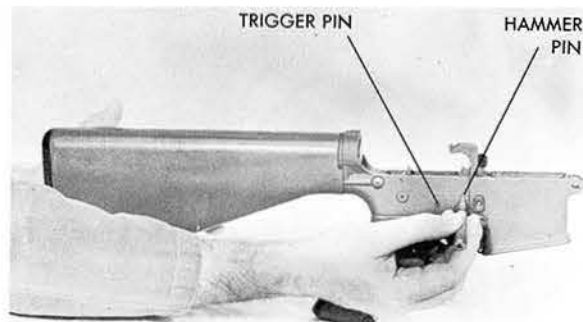

Figure 5-2

direction with a punch. Remove the trigger pin with the tail of the hammer spring. Lift out the trigger and disconnect assembly. Remove the bolt catch by driving the bolt catch pivot pin forward, as shown in figure 5-3. This pin is located on the side of the receiver. Be careful not to lose the small bolt catch spring and plunger located under the lower leg of the catch.

NOTE: The bolt catch pin is a rolled pin and must be replaced with a new one at reassembly.

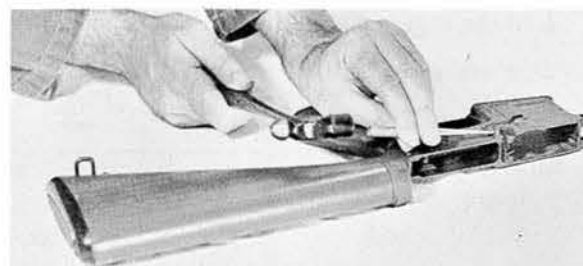

Figure 5-3

With the point of a cartridge, depress the magazine-catch button on the right side of the



Figure 5-4

receiver as far as it will go, as shown in figure 5-4. This will free the magazine-catch plate from its recess on the left side of the receiver. While holding the button depressed, rotate the magazine-catch plate counterclockwise, unscrewing it from the magazine-catch button, as shown in 5-4. Remove the plate, button, and spring from the lower receiver.

Insert a common screwdriver into the hollow pistol grip, and unscrew the pistol grip retaining screw. Remove the pistol grip, retaining screw, and lock washer. Remove the safety detent spring and plunger located in the right side of the lower receiver. The spring and plunger, shown in figure 5-5, are held in place by the upper face of the pistol grip and will drop out when the grip is removed. Press out the safety-selector lever to the left. Depress the buffer about 1/4 inch into the stock, and with a suitable tool depress the buffer retainer plunger as in figure 5-6. Use care in allowing the buffer and action spring to move forward out of the stock.

Unscrew the butt cap screw in the heel of the

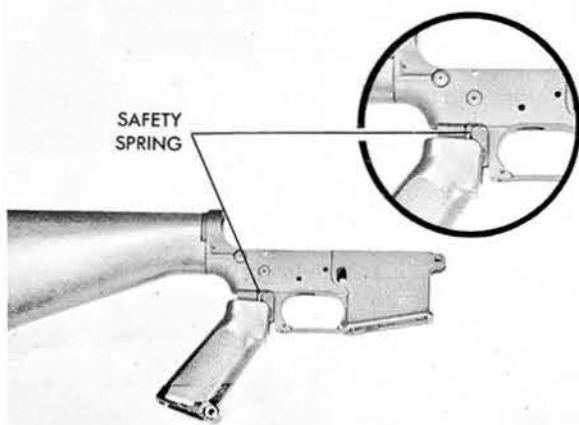

Figure 5-5

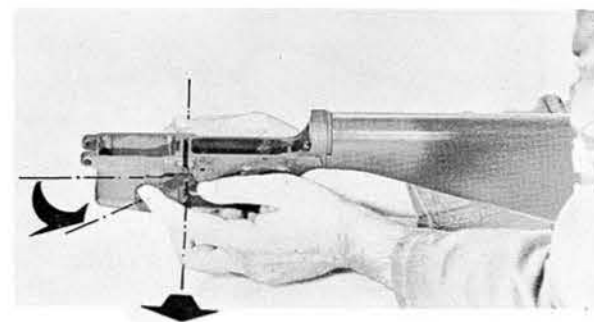

Figure 5-6

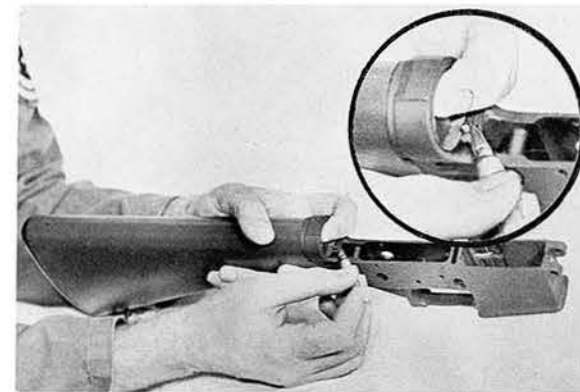

Figure 5-6

butt plate and slide the stock off the receiver extension to the rear. Be careful not to lose the take-down pin detent and spring, shown in figure 5-7, which are located in the right side of the receiver just ahead of the forward face of the stock.

Upper Receiver Group Disassembly

Pull back the slip ring located at the rear of the handguard, and remove the handguard halves by pulling outward and backward. Insert barrel remover fixture, #T 27823, in a vise; clamp the

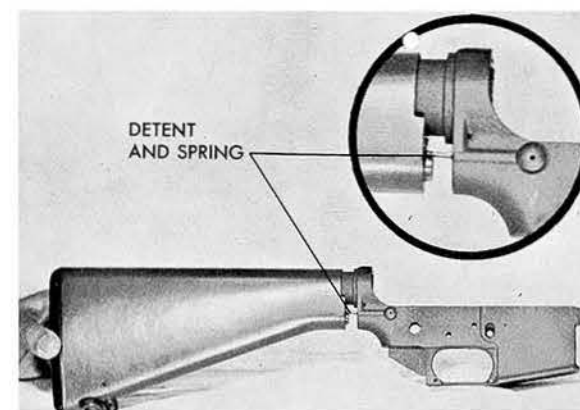

Figure 5-7

barrel into the fixture by tightening the vise, as shown in figure 5-8. The barrel should be clamped between the front sight and the flash suppressor with the ejection port facing down. Use a suitable strap wrench, and unscrew the flash suppressor from the muzzle of the barrel. Next, drive out the two front sight taper pins (toward the ejection port side) with a suitable punch.

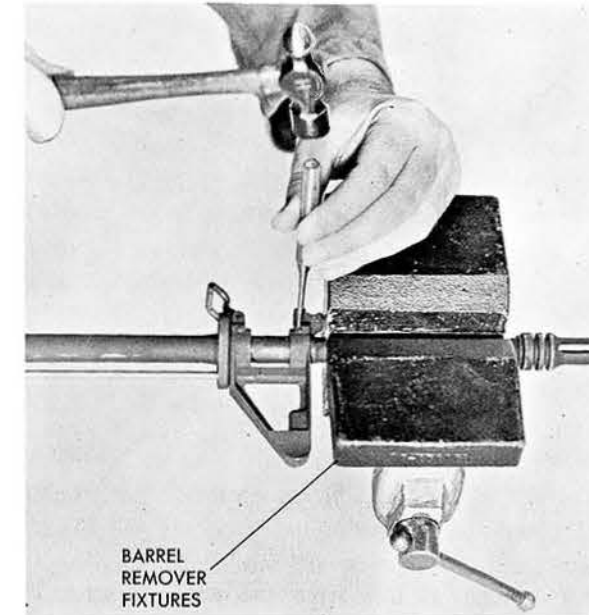

Figure 5-8

Remove the barrel from the vise, and slide the front sight and gas tube off the barrel, over the muzzle. Slide the handguard cap off the barrel. Now, with a proper-sized punch, drive out the gas tube retaining pin located in the horizontal leg of the front sight base, and remove the gas tube from the front sight assembly. This is a rolled pin and must be replaced with a new one at reassembly. Replace the barrel in the vise and barrel remover fixture, and with the wrench adapter, #T 27672, unscrew the barrel nut and slip ring assembly. Remove the barrel from the upper receiver.

CAUTION

Never remove the barrel extension from the barrel.

Front Sight Disassembly

To remove the front sight post from the front sight assembly, depress the front sight detent and rotate the sight post counterclockwise. Remove the post and lift out the detent and spring.

Rear Sight Disassembly

Remove the rear sight from the carrying handle portion of the upper receiver by driving out the windage drum pin, as shown in figure 5-9, and lift the drum off the shaft of the windage screw. Lift out the drum detent and spring. With a common screwdriver, unscrew the windage screw until

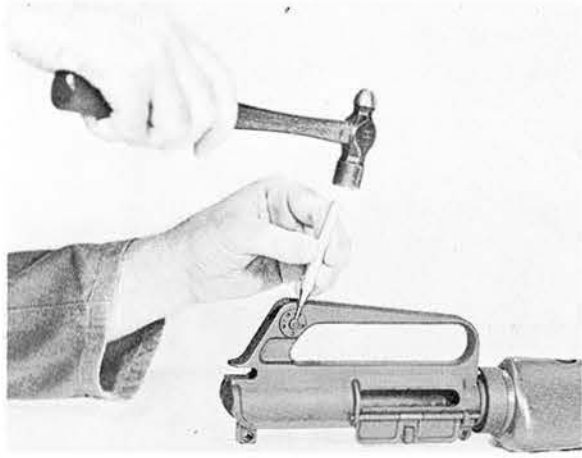

Figure 5-9

the rear sight is free from the windage screw. Withdraw the screw from the carrying handle, and lift out the rear sight and rear sight detent and spring.

Ejection Port Cover Disassembly

When the weapon is disassembled, the ejection port cover may be removed from the upper receiver without removing the small retaining ring on the forward end of the ejection port cover pin. Slide the pin forward out of the pivot holes in the receiver, and remove the ejection port cover assembly and spring.

NOTE: When reassembling the ejection port cover to the receiver, make certain that the cover pin retaining ring groove is forward.

Bolt Disassembly

To disassemble the bolt, hold pressure on the rear of the extractor with the thumb, and press out the extractor retaining pin with a punch or the tail of the hammer spring, as shown in figure 5-10. Lift the extractor, pin, and spring out of the bolt. With a suitable punch, drive the ejector retaining pin out of the bolt. Remove the ejector and spring from the face of the bolt. This is a rolled pin and must be replaced with a new one at reassembly.

(Caution—strong spring.) Figure 5-11 shows the disassembled bolt.

Magazine Disassembly

Hold the magazine firmly in the left hand with the bottom plate up and the front of the magazine facing you. Insert the tip of a cartridge into the

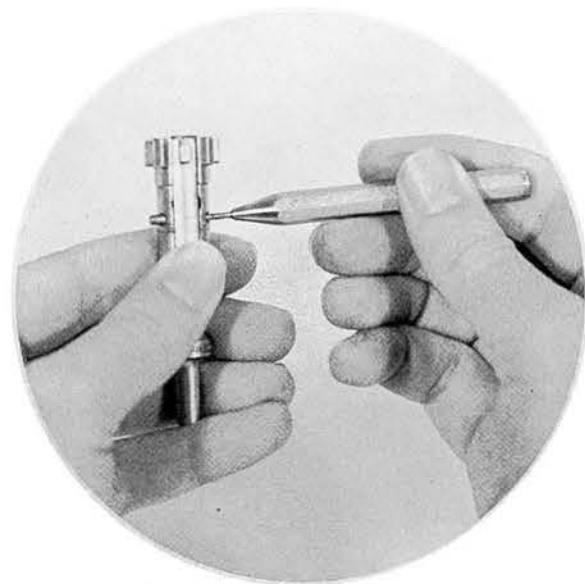

Figure 5-10

small hole in the bottom plate near the front edge (the edge facing you). Press down only enough with the cartridge to release the bottom plate catch spring, at the same time pressing toward the rear of

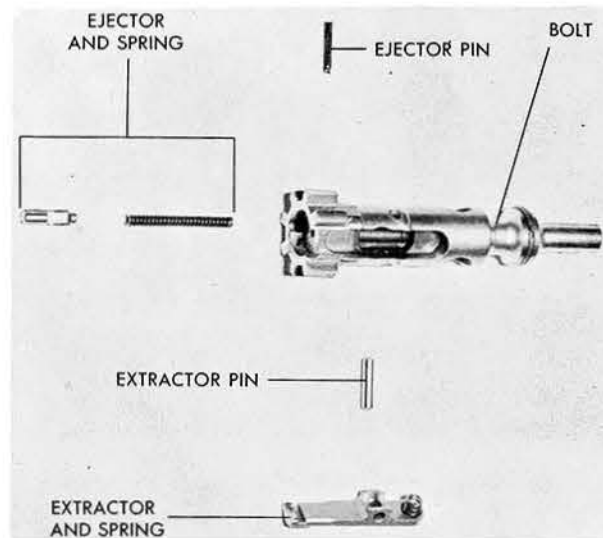

Figure 5-11

the magazine on the bottom plate with the thumb of the left hand. This is shown in figure 5-12. When the catch spring releases, slide the bottom plate away from you, to the rear of the magazine, far enough to grasp the bent tab on the bottom

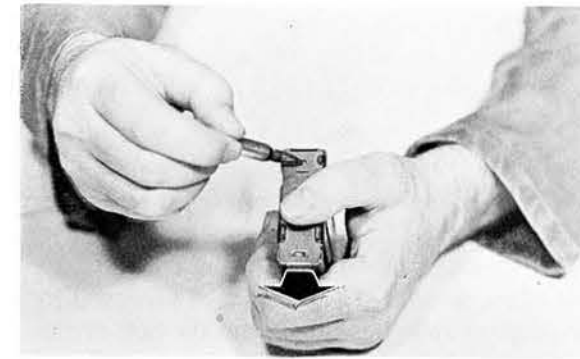

Figure 5-12

plate with the right hand, and slide the plate from the body of the magazine.

Work the follower spring upward, out of the magazine, as far as it will go. Rotate the follower spring 180° to the right so that it will lay flat across the bottom of the magazine, open end of the spring facing you. Grasp the protruding rear leg of the follower with the thumb and forefinger of the right hand and tilt the front end of the follower downward into the magazine at about a 45° angle, at the same time rolling the follower to the right, as shown in figure 5-13. As the edge of the follower clears the bottom plate retaining lug, lift out the follower and follower spring.

MAJOR INSPECTION

Inspection procedures for this weapon follow:

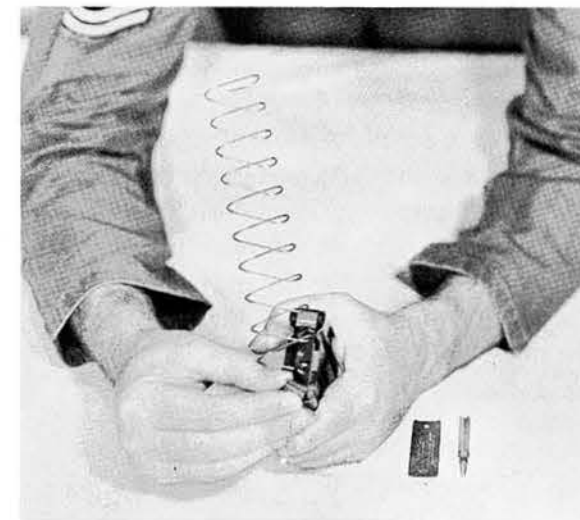

Figure 5-13

Barrel and Barrel Extension

With a magnifying glass, inspect the surfaces of the barrel and barrel extension for cracks or defects. Check the barrel extension for broken, burred, or worn locking lugs. Clean excessive carbon and dirt from the inner surfaces of the barrel extension. Check the bore for condition. Check for throat erosion by inserting tool #T 27670, maximum bore gage, into the firing chamber, as shown in figure 5-14. The tool should not pass into the bore.

Check barrel alinement with drop gage #T 27442. The gage should pass smoothly through the barrel. Pressure may be needed as the tool passes the gas port, but this pressure should be very light. Clean the gas port with a hand-held #43 drill.

NOTE: Head space is checked after reassembly of the barrel and upper receiver. This is explained later.

Front Sight and Gas Tube

With a magnifying glass, check the front sight for cracks and general condition. Check the gas tube for cracks, alinement, and condition. Clean carbon deposits from the tube surfaces which mate with the receiver.

Upper and Lower Receiver and Internal Parts

Inspect the receiver and all parts for cracks with a magnifying glass. Visually inspect all parts for general condition and signs of excessive wear. Check the condition of all springs.

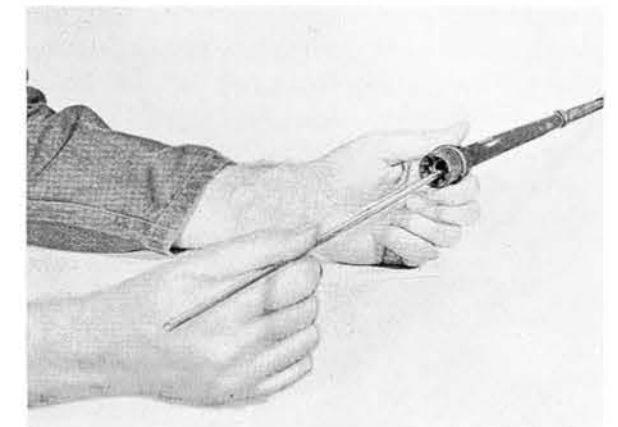

Figure 5-14

Bolt and Bolt Carrier

Check for cracks in the bolt with a magnifying glass. Visually inspect the bolt for condition of the locking lugs, pitted or chipped bolt face, and elongated firing pin hole. Clean the extractor recess. Inspect the bolt rings for condition and proper spacing of bolt ring gaps. Position rings so that ring gaps are on the opposite sides of the bolt, as shown in figure 5-15. Visually inspect the firing pin for wear and burrs. Insert the firing pin into the bolt and, with tool #T 27669, check firing pin protrusion beyond the bolt face. Firing pin protrusion should be between .028" and .036".

Use a magnifying glass to inspect the bolt carrier for cracks. Visually inspect all surfaces of the bolt carriers for burrs, chips, and general condition. Inspect the bolt carrier key for security, burrs, and excessive carbon. Visually check socket head cap screws for staking. Clean gas relief ports with a hand-held #36 drill.

REPLACEMENT AND ADJUSTMENT OF PARTS

All replacement parts are interchangeable and require no adjustment when being installed in the AR-15 rifle. However, to insure proper function and full reliability, the following precautions should be taken:

- Do not interchange bolts and bolt carriers. Keep a bolt with its original bolt carrier. If replacement of either part becomes necessary, carefully check the new part to see that it fits properly, operates smoothly, and that the correct head space is provided.
- Do not mix parts of one weapon with those of another. When disassembling a rifle, keep the parts separated from parts of other rifles. Mating metal surfaces adjust themselves to each other through wear, and operate best when kept together.

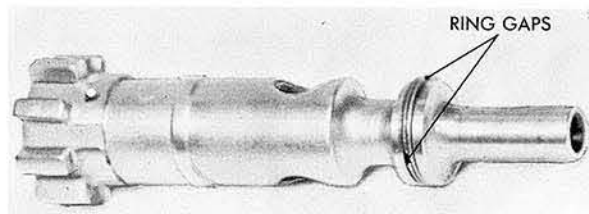

Figure 5-15

ASSEMBLY

Upper Receiver Group Assembly

The upper receiver group is assembled by reversing the procedure outlined in disassembly instructions. Torque the barrel retaining nut to 65 foot-pounds. Make certain to align a serration of the retaining nut with the gas tube hole in the front of the receiver. Check gas tube alignment by installing the charging handle and the bolt carrier (without bolt) into the upper receiver. Slide the bolt carrier all the way forward in the receiver, making sure that the bolt carrier key slides smoothly over the end of the gas tube without binding or distorting the gas tube.

Bolt and Bolt Carrier Assembly

Assemble the bolt by reversing the procedures in disassembly instructions. Reassemble the bolt to the bolt carrier by reversing the field stripping procedure in Chapter 4.

Checking Head Space

Insert the charging handle and the assembled bolt and bolt carrier into the upper receiver. Insert head space gage, #T 27921, as shown in figure 5-16, into the firing chamber of the barrel. With moderate hand pressure on the rear of the bolt carrier, press the carrier forward so that the bolt locking lugs enter the barrel extension. The bolt should rotate only slightly, but *it should not lock completely*. If the bolt locks completely, the head space is excessive and may be corrected by changing the bolt, or the barrel and barrel extension. If items are replaced, recheck head space.

Lower Receiver Group Assembly

Assemble the lower receiver group by reversing the procedures outlined in paragraphs on disassembly. During assembly, insure that the hammer spring ends are resting on the trigger pin, as shown in figure 5-17, and the automatic sear spring end is in the groove in the safety. Figure 5-18 shows a locally manufactured tool to assist in the installation of the hammer and hammer spring.

Magazine Assembly

Assemble the magazine by reversing the procedures explained in the paragraph on magazine disassembly.

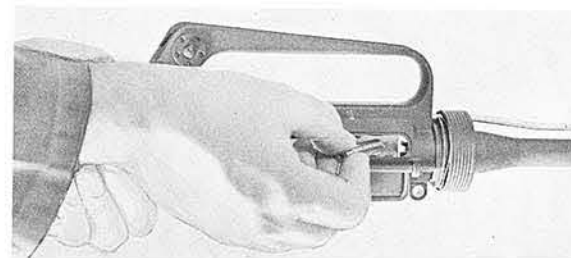

Figure 5-16

Final Assembly

Rejoin the upper and lower receiver by mating the pivot pin holes and inserting the receiver pivot pin. Complete the assembly of the weapon by reversing the field stripping procedures outlined in Chapter 4.

Reporting Defective Parts

Broken or defective parts will be reported on an Unsatisfactory Report as prescribed in T.O. 00-35D-54. Reports will be submitted to the responsible depot as prescribed in T.O. 00-25-115, *AFLC Maintenance Engineering Management Assignments*.

FUNCTION CHECK AND TEST FIRE

Following each detailed disassembly or whenever improper function is suspected, the weapon will be function checked as outlined in Chapter 4.

Test Fire

The rifle will be test fired following the replacement of a major component which could affect the function or accuracy of the weapon, and the proper function of which could not be detected by a routine function check. Test firing will be conducted on a suitable range.

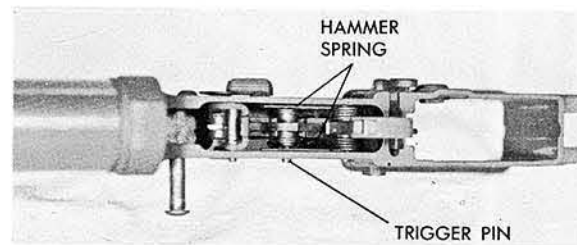

Figure 5-17

To test fire the weapon, load with a full 20 round magazine. Charge the weapon and set the safety-selector on SAFE. Keep the weapon pointed down range and exert moderate to heavy pressure on the trigger making certain that the weapon does not fire with the safety on.

Set the safety-selector to the SEMI position, and fire two 5 round groups. Hold pressure on the trigger following each round to make certain that the weapon does not "double" (fire more than one round).

Set the safety-selector to the AUTO position, and fire the remainder of the magazine in bursts of four or five rounds. Make certain that the weapon ceases to fire as soon as the trigger is released.

Reload the weapon with a full 20 round magazine and set the safety-selector on SEMI. Hold the weapon loosely in both hands at the side of the body to allow full recoil. Fire the full magazine, permitting the rifle to recoil freely, and make certain the rifle cycles completely. If the rifle fails to cycle, there is insufficient reserve of energy caused by loss of gas pressure or binding parts.

Fixed limits of accuracy cannot be established in this manual since this is largely dependent on the abilities of the firer and climatic conditions. However, this weapon should maintain consistent 4", center to center, groups at 100 yards. Groups may tend to open if the weapon is fired with the bipod or bayonet installed.



Figure 5-18

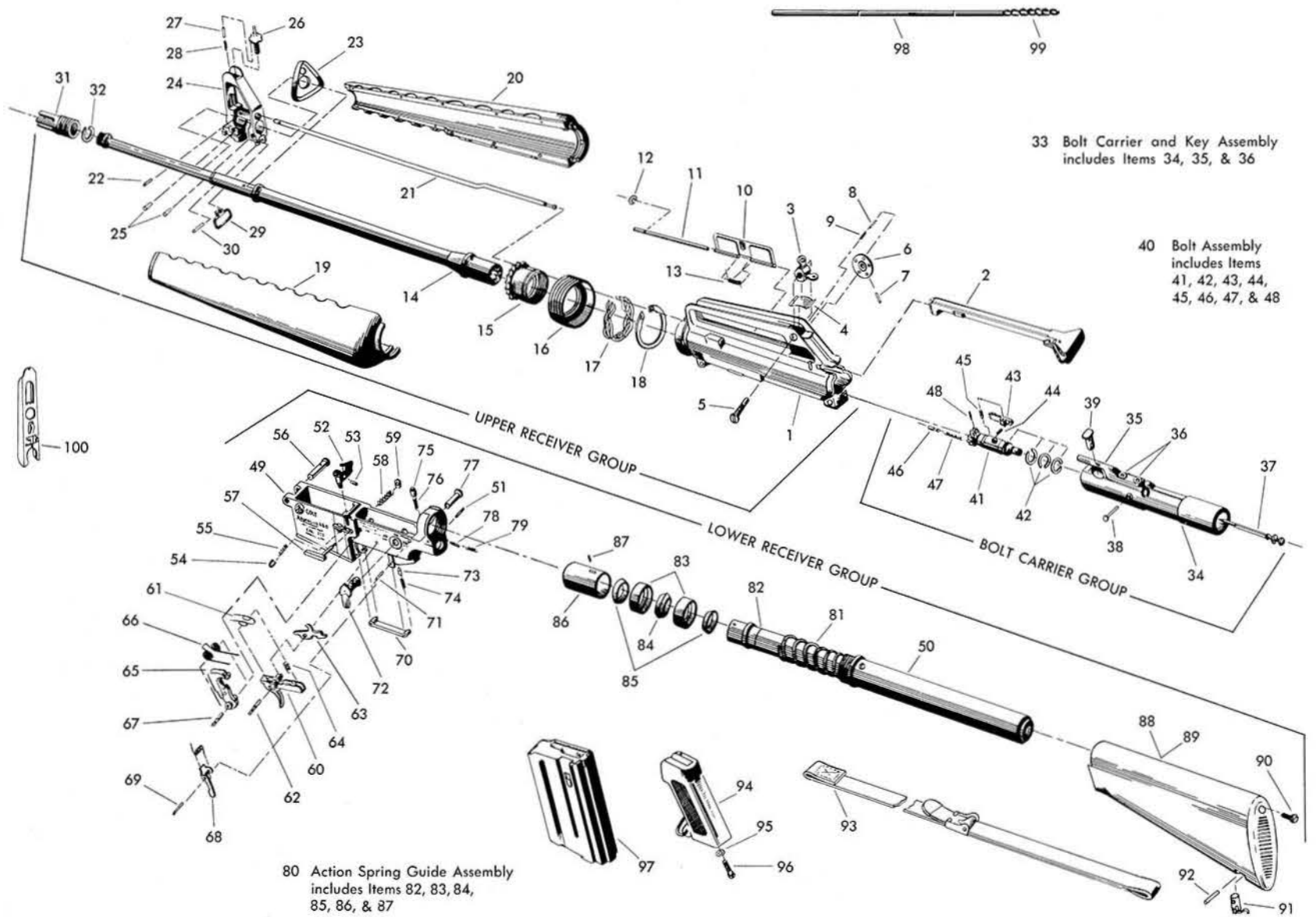

Figure 5-19

PARTS LIST

ITEM NUMBER	PART NUMBER	NAME	ITEM NUMBER	PART NUMBER	NAME	ITEM NUMBER	PART NUMBER	NAME	ITEM NUMBER	PART NUMBER	NAME
UPPER RECEIVER GROUP			28	61709	Front Sight Detent Spring	54	62178	Bolt Catch Plunger	85	61577	Buffer End Ring
1	61546	Receiver—Upper	29	61322	Front Swivel	55	62177	Bolt Catch Spring	86	61576	Buffer Cap
2	62114	Charging Handle Assembly	30	95103	Front Swivel Pin	56	95601	Receiver Pivot Pin Assembly	87	95101	Buffer Pin
3	61700	Rear Sight	31	62182	Flash Suppressor	57	61604	Magazine Catch Assembly	88	61935	Stock Assembly Molded (No Swivel)
4	61708	Rear Sight Spring	32	62126	Flash Suppressor, Lock Washer	58	61759	Magazine Catch Spring	89	62192	Stock Assembly Molded (With Swivel)
5	61702	Rear Sight Windage Screw	BOLT CARRIER GROUP			60	61955	Trigger	90	92601	Butt Cap Screw
6	61703	Rear Sight Windage Drum	33	61826	Bolt Carrier and Key Assembly	61	61657	Trigger Spring	91	62118	Rear Swivel Assembly (Butt)
7	95101	Rear Sight Windage Drum Pin	34	61544	Bolt Carrier	62	61654	Trigger Pin	92	95111	Rear Swivel Roll Pin
8	61755	Rear Sight Detent	35	61547	Bolt Carrier Key	63	61918	Disconnect	93	62149	Sling (Butt Stock)
9	61754	Rear Sight Detent Spring	36	92201	Socket Head Cap Screw	64	61925	Disconnect Spring	94	62194	Pistol Grip
10	62112	Ejection Port Cover Assembly	37	61584	Firing Pin	65	62117	Hammer Assembly	95	90001	Lockwasher
11	61658	Ejection Port Cover Pin	38	61561	Firing Pin Retaining Pin	66	61697	Hammer Spring	96	92701	Pistol Grip Screw
12	90402	Ejection Port Cover Pin Retaining Ring	39	61704	Bolt Cam Pin	67	61654	Hammer Pin	97	62103	Magazine Assembly, Aluminum (20 Round Capacity)
13	61518	Ejection Port Cover Spring	40	62116	Bolt Assembly	68	61622	Automatic Sear Assembly	98	94004	Cleaning Rod Assembly
14	62180	Barrel Assembly	41	61538	Bolt	69	61615	Automatic Sear Pin	99	91206	Cleaning Brush
15	61902	Barrel Nut	42	61540	Bolt Rings	70	61970	Trigger Guard Assembly	100	62214	Grenade Sight (ATK-75mm)
16	61901	Hand Guard Slip Ring	43	61562	Extractor	71	95106	Trigger Guard Pivot Pin	ACCESSORIES		
17	61962	Hand Guard Slip Ring Spring Assembly	44	61568	Extractor Spring	72	61959	Safety-Selector Lever	These accessories have not been adopted and are not available through normal distribution channels. When adopted, standardized, and procured, they will be authorized in appropriate authorization documents.		
18	90403	Hand Guard Snap Ring	45	61563	Extractor Pin	73	61785	Safety-Selector Lever Detent	NOT SHOWN	62122	Bipod Assembly
19	62196	Hand Guard Assembly LH	46	61564	Ejector	74	61569	Safety-Selector Lever Detent Spring		62137	Bipod Case
20	62198	Hand Guard Assembly RH	47	61569	Ejector Spring	75	61582	Buffer Retainer		62082	Bayonet Assembly
21	61645	Gas Tube Detail Assembly (Completed and bent)	48	95102	Ejector Pin	76	61694	Buffer Retainer Spring		62138	Bayonet Scabbard
22	95108	Gas Tube Pin	LOWER RECEIVER GROUP			77	61655	Takedown Pin		62133	Safety, Non-automatic Fire
23	62087	Hand Guard Cap	49	62200	Lower Receiver	78	61698	Takedown Pin Detent		62135	Sling (Pistol Grip)
24	62068	Front Sight	50	61574	Lower Receiver Extension	79	61692	Takedown Pin Detent Spring		62215	Scope Mount Assembly
25	62086	Front Sight Taper Pins	51	95107	Lower Receiver Extension Pin	80	62119	Action Spring Guide Assembly		62142	Scope Assembly
26	61706	Front Sight Post	52	61599	Bolt Catch	81	61581	Action Spring		62136	Scope Case
27	61705	Front Sight Detent	53	95105	Bolt Catch Pin	82	61580	Action Spring Guide			
						83	61578	Buffer Ring, Outer			
						84	61579	Buffer Ring, Inner			

MALFUNCTIONS

The chart lists common malfunctions, causes, and corrective actions.

Malfunction	Cause	Corrective Action
Bolt fails to lock to the rear after the last round.	Faulty magazine.	Replace magazine.
	Broken bolt catch and/or spring.	Replace bolt catch or spring.
Failure to feed.	Faulty magazine.	Replace.
	Binding bolt and bolt carrier.	Disassemble and clean. (On a new weapon, one or two drops of oil on the bolt rings will remedy this trouble.)
	Restricted buffer.	Remove drive spring and buffer and clean.
Failure to cycle with safety-selector set at AUTO.	Broken automatic sear or spring.	Replace faulty part.
	Faulty safety-selector lever.	Replace.
Failure to fire.	Improperly assembled bolt and firing pin.	Check for proper assembly.
	Broken firing pin. Broken hammer spring.	Replace. Replace.
	Broken disconnect or spring.	Replace.
	Improperly installed trigger or hammer pin.	Check for proper installation.
Fires with safety-selector set on SAFE.	Faulty safety-selector.	Replace.
	Defective trigger.	Replace.
With safety-selector lever on SEMI, fires when trigger is released.	Faulty or misaligned trigger pin.	Replace.
	Defective trigger.	Replace.
Bolt seizes (will not rotate or unlock).	Carboned, dirty, or burred bolt group.	Hold rifle in vertical position and strike butt sharply on ground to free the bolt. Remove bolt and clean.

SPECIAL TOOLS

Refer to figure 5-20, for tool identification.

- T 27823 Barrel Remover Fixture
- T 27672 Adapter
- T 27669 Protrusion Gage Firing Pin
- T 27921 Head Space Gage (Field Type)
- T 27670 Maximum Bore Gage
- T 27442 Bore Drop Plug

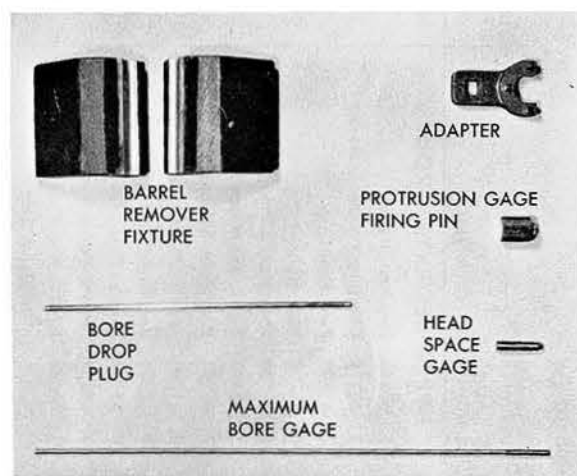

Figure 5-20

CHAPTER 6

Ammunition

This chapter includes available information on the types of ammunition used in the AR-15 rifle. The following types of ammunition, manufactured commercially, are for the purposes indicated.

The following listed ammunition has not been adopted and is not available through normal distribution channels. When the listed ammunition is adopted, standardized, and procured it will be authorized in appropriate authorization documents.

TYPES

Ball

The ball ammunition is a 5.56 mm (caliber .223) center fire cartridge with a 55 grain gilding-metal jacketed, lead alloy core bullet. The primer and case are waterproofed. The ball round is the basic cartridge for field use.

- Tracer
- Grenade launching
- Blank
- Grenades
 - 75 mm
 - 62 mm Anti-Tank
 - 55 mm Practice
 - 55 mm Anti-Personnel

BALLISTIC DATA

Approximate range, velocity, and energy of the ball ammunition is shown in figure 6-1.

Figure 6-1

Range (yds.)	Velocity (fps.)	Energy (ft. lbs.)	Drop (in.)	Mid-Range Trajectory (in.)
0	3265	1300	—	—
100	2905	1035	1.75	5
200	2550	795	7.67	2.1
300	2210	595	18.98	5.4
400	1885	430	37.56	11.1
500	1590	310	66.30	20.6

Penetration Tests

Velocity of 3250 fps at the muzzle, imparted to the 55 grain, full-jacketed, boat-tailed bullet makes this an extremely effective military cartridge with excellent combat accuracy and penetration. Tests show the following penetration at ranges indicated:

At 600 yards:

- Penetrates one side of U.S. steel helmet and heavily dents the opposite side.

At 500 yards:

- 7 to 13, 1" pine boards
- 10 gage (.135) steel plate

- Both sides of U.S. steel helmet
- Body armor

At 200 yards:

- 3/16" steel plate

PACKAGING

Presently, 20 rounds per commercial carton, 50 cartons per commercial fiber or wooden packing case are available. A suitable military ammunition pack is being developed. Stripper clips, bandoliers, and cartridge belts are being designed.

BY ORDER OF THE SECRETARY OF THE AIR FORCE

OFFICIAL

R. J. PUGH
Colonel, USAF
Director of Administrative Services

CURTIS E. LEMAY
Chief of Staff